

AUTOSPORT

www.autosport.com • NOVEMBER 28 2013 • £3.50

BRAZILIAN GP ACTION

WEBBER LAPS IT UP

Aussie's emotional farewell
as Vettel matches Ascari

PLUS



EXCLUSIVE TRACK TEST
We drive the BTCC winner



**McLAREN AUTOSPORT
BRDC AWARD 2013**
Meet this year's finalists



haymarket
9 770269 946241
48
C\$8.99

GTi IS BACK



PEUGEOT RECOMMENDS TOTAL Official Fuel Consumption in mpg (l/100km) and CO₂ emissions (g/km) for the 208 GTi are: Urban 34.4 (8.2), Extra Urban 60.1 (4.7), Combined 47.9 (5.9) and CO₂ 139 (g/km). MPG figures are achieved under official EU test conditions, intended as a guide for comparative purposes only, and may not reflect actual on-the-road driving conditions.

NEW PEUGEOT 208 GTi

MOTION & EMOTION



PEUGEOT

POLE POSITION

Well done Seb. Now please stop winning!

IT WAS FITTING THAT A SEASON DOMINATED BY Sebastian Vettel should end with him equalling one of the world championship's longest-standing records.

I say this with utter respect for what Vettel and Red Bull have achieved, but I really hope it's another 60 years before the same driver wins nine races in row.

There's every reason to think that the competitive order will be shaken up next year, following the most dramatic change in engine regulations since turbos were banned in the late 1980s.

One driver who won't get to experience the new order will be Mark Webber, who bowed out of Formula 1 with a strong run to second. The driver market has seldom been as fluid as it is now, as the teams struggle to meet the financial demands the new regulations have placed upon them.

That it's feasible that one of Nico Hulkenberg, Romain Grosjean or Paul di Resta will find themselves out of a seat next year should set alarm bells ringing.

F1 in its current state is unsustainable, but is anyone within the sport capable of saving it from itself?



ANDREW VAN DE BURGT EDITOR-IN-CHIEF
andrew.vandeburgt@haymarket.com
@AvdaB



PRIVATE EAR



So it's
goodnight
from me

And it's
goodnight
from him

BOTH PICS: DUNBAR/LAT

FIND US ON



Cover Image: Mason/Getty
Insets: Ebrey/LAT, LAT

PIT & PADDOCK

6 **THIS WEEK IN F1**

9 **MARK HUGHES: MPH COLUMN**

10 **THIS WEEK IN MOTORSPORT**

13 **THE INSIDE LINE: DEREK WARWICK**

14 **BRAZILIAN GRAND PRIX**

Vettel completes his domination of late-season 2013 as Webber bows out. Full report, plus all the results, driver-by-driver analysis and tech upgrades

DEBRIEF

32 **WEBBER: BETTER THAN HE LOOKED**

Analysis of Aussie's time alongside a phenomenon

34 **F1 PRESSES RESET BUTTON FOR 2014**

Why Red Bull's recent domination could be ended

36 **GT REVISIONS CLEAR A NEW PATH**

Ratel hopes for influx of top competitors

39 **15 QUESTIONS: DAVID COULTHARD**

He hasn't listed not winning the '89 Fford Festival as his biggest disappointment, but we'll let him off

FEATURES

40 **BTCC HONDA CIVIC TRACK TEST**

Behind the wheel of Andrew Jordan's title winner

50 **ELMS REVIEW**

Signatech does the job for Alpine in LMP2 ranks

52 **SUPERSTARS REVIEW**

Morbidelli and Audi beat the heavy metal in Italy

56 **WATSON AND PENSKE LOOK BACK**

Talking to the men behind an intriguing subplot of F1 1976: victory in Austria and the loss of a beard!

60 **McLAREN AUTOSPORT BRDC AWARD**

Six finalists hit the track at Silverstone. Here's what they went through, and how they think they did

RACE CENTRE

46 **FIA GT BAKU**

Audi pair Ortelli and Vanthoor win and claim crown

49 **V8 SUPERCARS**

SUBSCRIBE FOR A FREE GIFT

80 **FREE ASTON POLO SHIRT**

Subscribe for a great free gift and digital package

CLUB AUTOSPORT

77 **AUTOSPORT 3 HOURS REVAMPED**

Tweaks to bring historic GTs to Snetterton enduro

78 **BRITS LINE UP FOR DUBAI 24**

Plant returns to action in Team Parker Porker

83 **NATIONAL REPORT**

Britcar/F4 Brands Hatch

84 **SEASON REVIEWS**

British Endurance Championship; British Rallycross Championship; British Hillclimb Championship

THE BACK STRAIGHT

86 **THIS WEEK**

Readers' letters; best pictures; product reviews

88 **WHAT'S ON**

The best track and TV action in the coming week

90 **RACE OF MY LIFE: TOMMY KRISTOFFERSSON**

THE BIG PICTURE

For the first time, The Big Picture comes from the streets of... Azerbaijan. FIA GT contenders disrupt the traffic in Baku before fighting out their series finale





This week in F1

MALDONADO KEY TO DRIVER MARKET

Pastor Maldonado was closing on a deal to drive for the Lotus team next year as AUTOSPORT closed for press.

The Venezuelan, who has raced for Williams for the past three seasons, has been in advanced negotiations with both the Enstone team and Sauber over the past week. Lotus was planning to sign Nico Hulkenberg, but that was dependent on the

mooted investment deal with Quantum Motorsports being completed earlier.

The deal to take Venezuelan oil giant PDVSA to the team and then bring in Maldonado to satisfy the need for a Venezuelan driver was close to completion by the end of last weekend's Brazilian GP season finale. This was set to leave Force India to field Hulkenberg and Sergio Perez, with Adrian Sutil moving to Sauber.

➔ WWW.AUTOSPORT.COM FOR DRIVER MARKET LATEST



Alonso hails Hulkenberg

Fernando Alonso has described Sauber driver Nico Hulkenberg as "one of the best drivers on the grid" and suggested the German deserves a top drive in F1.

Hulkenberg was in contention to be Alonso's Ferrari team-mate next year, but was overlooked in favour of Kimi Raikkonen.



6

COATES/LAT

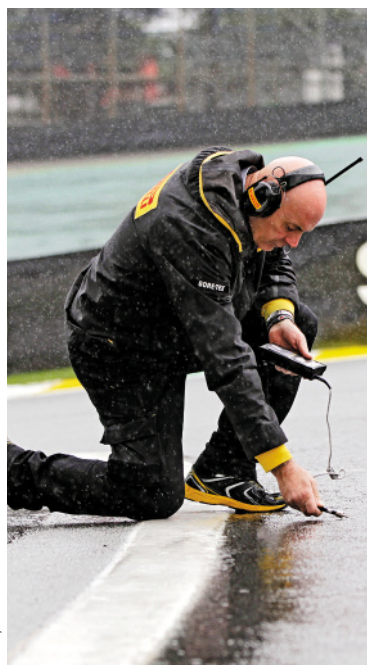

HONE/LAT

Pirelli wants more wet testing

Pirelli believes restrictions on its tyre-testing activities has prevented it improving its wet-weather rubber as quickly as it would like to.

The final part of Brazilian GP qualifying was delayed by 40 minutes at Interlagos last Saturday, leading to fan uproar. Drivers backed the delay, stating that conditions were initially undriveable thanks to standing water. But there was a feeling that the session could have restarted 10 minutes earlier given how quickly cars were able to switch to intermediate rubber once Q3 did get underway.

The lack of testing opportunities for Pirelli has been a constant source of frustration for the tyre company, which has produced rubber that, while perfectly useable, has room for improvement.

"How many testing sessions are we allowed to do?" asked Pirelli motorsport chief Paul Hembery when quizzed about its wet tyres. "We have made some changes for next year but at the end of the day wet tyres are developed doing wet-track testing and we have had minimal ability to develop them."

NO RUNNING FOR 2014 RUBBER

Pirelli's plan for all teams to try out its prototype 2014 rubber during Friday practice at Interlagos was ruined by rain. Sebastian Vettel did one slow lap in wet conditions on the tyres, but no meaningful data was gathered by Pirelli.

BIG NUMBER

247

Jenson Button eclipsed David Coulthard's record for most world championship race starts by a British driver at Interlagos

For all the breaking news, visit AUTOSPORT.COM

Abu Dhabi set for 2014 finale

Abu Dhabi is likely to finish the 2014 grand prix season on November 16 thanks to a calendar reshuffle set to be confirmed at a meeting of the FIA World Motor Sport Council on December 6. The revised calendar should feature 19 races, down from the original 22, thanks to the loss of Mexico, Korea and New Jersey.



ETHERINGTON/LAT

DID YOU KNOW?

Next year, Abu Dhabi will host the F1 season finale for the third time. Adelaide is the circuit that has done so the most times, with 11 from 1985-1995.



KOVALAINEN ADMITS HE 'UNDERESTIMATED' LOTUS STAND-IN CHALLENGE

Heikki Kovalainen has admitted he underestimated the challenge facing him when called up to replace Kimi Raikkonen at Lotus for the final two races of 2013.

"The amount of errors I made is more than I anticipated and I have to admit that maybe it was too big a challenge and I underestimated it," he said.



FERRARO/LAT

STAND IN STRUGGLERS

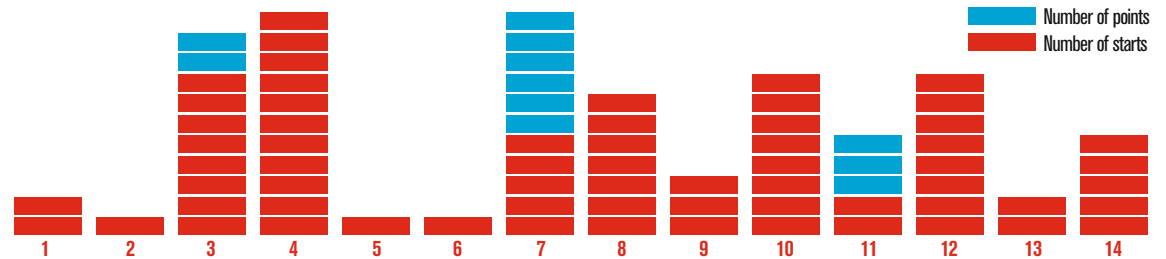

1 Heikki Kovalainen Lotus, 2013



5 Karun Chandhok Lotus, 2011



9 Christian Klien HRT, 2010



12 Jaime Alguersuari Toro Rosso, 2009



2 Jerome d'Ambrosio Lotus, 2012



6 Pedro de la Rosa Sauber, 2011



10 Romain Grosjean Renault, 2009



13 Luca Badoer Ferrari, 2009



3 Bruno Senna Renault, 2011



7 Nick Heidfeld Sauber, 2010



11 Kamui Kobayashi Toyota, 2009



14 Vitantonio Liuzzi Force India, 2009



4 Daniel Ricciardo HRT, 2011



8 Sakon Yamamoto HRT, 2010

Heikki Kovalainen is not the first driver to have struggled after being dropped into competitive action during a campaign. Since the

in-season testing ban, 14 drivers have made their seasonal debuts as stand-ins or replacements, but only three have scored points.



Curtain falls on V8 engine era

Formula 1's 2.4-litre V8 engine formula was brought to a close at Interlagos on Sunday, with Renault claiming its 60th victory of the era. The engines were brought in at the start of 2006 to replace the previous three-litre V10s and they will be superseded by 1.6-litre turbocharged V6s next year.

F1 WINS BY ENGINE 2006-2013

ENGINE	WINS
Renault	60
Mercedes	46
Ferrari	39
Cosworth	0



MASON/GETTY

Kvyat surprised by progress

Toro Rosso 2014 signing Daniil Kvyat admits he is struck by the impressive start he has made in F1 during his two Friday practice outings for the team at Austin and Interlagos. "A little bit, yes," the 19-year-old Russian admitted when asked if he was surprised. "You can never know how fast you can go in a Formula 1 car, as it is totally different. This has brought me confidence - I am getting used to the car."

WE ARE FAMILY



FORMULA ONE INSPIRED ENERGY ENGINES



NEW RENAULT CLIO†
From £129 per month*, plus 1 year's free insurance**



ALL-NEW RENAULT CAPTUR CROSSOVER†
From £179 per month*

FORMULA ONE TECHNOLOGY = BETTER FUEL ECONOMY + REDUCED EMISSIONS

Our Formula One inspired ENERGY engines deliver up to 21% better fuel consumption and reduced CO₂ emissions. Book a test drive today at renault.co.uk/formulaone

4 **FOUR YEARS WARRANTY**
INCLUDED **ROADSIDE COVER**
INCLUDED **SERVICING**
FINANCE PACKAGE



DRIVE THE CHANGE



The official fuel consumption figures in mpg (l/100km) for the Renault range are: Urban 27.2 (10.4)–78.5 (3.6); Extra Urban 45.6 (6.2)–94.2 (3.0); Combined 36.7 (7.7)–88.3 (3.2). The official CO₂ emissions for the range are 178–83g/km. Based on EU Directive and Regulation 692/2008 test environment figures. Fuel consumption and CO₂ may vary according to driving styles, road conditions and other factors. †Cars shown are Clio and Captur Dynamique S MediaNav TCe 90 S&S from £189 and £219 per month.

† Terms and exclusions apply. Warranty 100,000 miles. Service 48,000 miles. Visit renault.co.uk/4plus for details. Finance provided by RCI Financial Services Limited, PO Box 149, Watford WD17 1FJ. Guarantees and indemnities may be required. You must be at least 18 and a UK resident (excluding the Isle of Man and Channel Islands) to apply. *Rental stated is for Renault Lease. If you choose Renault Lease then you will not own the car. When you have paid the final rental at the end of the contract, you can keep using the car and pay an annual rental equivalent to one monthly rental. Typical example: Renault Clio Expression 1.2 16V 75 with insurance included, customer deposit £2,624 inc. VAT followed by 48 monthly payments of £129 inc. VAT, final payment £3,835 inc. VAT. Typical example: New Captur Dynamique MediaNav TCe 90 S&S, customer deposit £2,849 inc. VAT followed by 48 monthly payments of £179 inc. VAT, final payment £5,846 inc. VAT. A finance facility fee of £149 will be payable with the advance rental. Available at participating dealers only. Offers cannot be used in conjunction with other schemes or finance offers and are available on new vehicles when ordered before 31 December 2013. Cars shown may have optional metallic paint, available at an additional £495 (or £595 for i.d. paint), plus £300 for painted roof on Captur. **Insurance is available to Renault Finance customers only (exc. Northern Ireland) with a new Renault Clio Expression 1.2 16V 75. Visit renault.co.uk/insurance for details.

Mark Hughes

MPH



FIA president Jean Todt's second term is unlikely to be as trouble-free as the first. What he needs is a right-hand man, an enforcer...

In two weeks' time Jean Todt will get re-elected as FIA president, now that his only opponent has pulled out of the race. Although we should remember that the FIA's remit extends far outside of Formula 1, Todt's first four years have been marked by the absence of the sort of conflict seen during the era of his predecessor Max Mosley.

In general, F1 has been a more peaceful place under Todt's reign. The only time he has had to force anything contentious through – the green formula conceived during Mosley's time that comes into effect next year – he has been firm yet free from rancour.

But in his forthcoming four-year term there is much in F1 that desperately needs attending to – and it will not happen through a hands-off approach. It will also probably not happen without conflict. But it needs to happen regardless. F1 desperately needs to roll its costs back and that can only take place with coercion from the governing body.

"If we cut the budgets in half we would still go racing," said Mercedes' Ross Brawn in Brazil. "It's the standards of which we want to go racing that cause the pressure on the budget. It's not that there's insufficient money, it's the fact that we all want to compete at the highest possible standard and that means we push the budgets as hard as we can. If everybody's budget tomorrow was reduced by 50 per cent, it wouldn't make any difference."

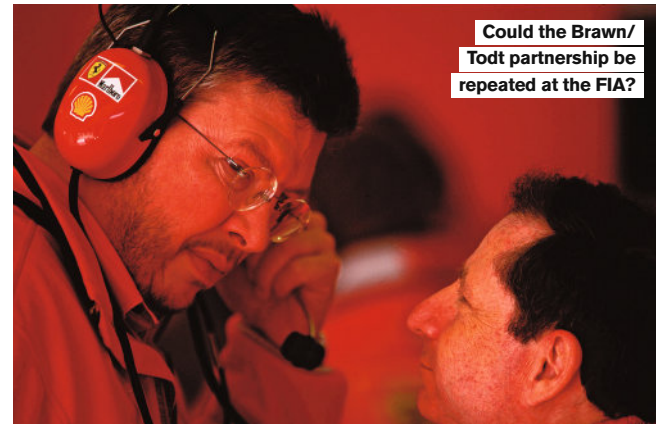

that had to be policed, we believe by the FIA, but it seemed we couldn't get enough agreement within the teams, so it failed. I don't think it failed because it wouldn't work. In my view it failed because we couldn't engage the governing body in the system. Whatever system we have is going to affect the competitiveness of the teams and therefore has to be controlled by the sporting body. Any attempt to have self-regulation of something so important as budget and resource is futile." Mmm. Now, I wonder who there could be that could

"F1 can't police itself for the common good when a competitive advantage is to be had"

So, could that ever happen? "No," answered Ross. "But that's a fact. It wasn't so many years ago that we were able to come to every race at every track with reliable cars for half what we are spending now. That's the nature of F1."

Precisely. That's the nature of a sport comprised of intensely competitive entities and individuals. It cannot possibly police itself for the common good when there's a competitive advantage to be had.

The Resource Restriction Agreement has been a partial success – and that was devised largely by the teams. But that's as far as it's ever going to go, because once the terms have been agreed, the teams are then individually looking for ways around them, just as with the technical regulations. It cannot be self-policing; it must be enforced by the governing body. Brawn has arrived at exactly that conclusion. "The RRA was a system that could work but not with self-regulation. It was a system

perhaps join the FIA and take on the job of rolling back the budgets and enforcing it? Someone perhaps coming to the end of his time as a team principal, the perfect poacher turned gamekeeper, who has spent his way to success with several teams? Someone who works well and has a good relationship with Jean Todt? Someone who could seamlessly join up the broad policy with the nitty gritty? Someone who knows the workings of the teams, understands the politics, doesn't mind getting his hands dirty with them? Someone who could get Ferrari onside – always an essential ingredient to the success or otherwise of F1 policy?

Todt and Brawn together could get this done. Just as they won five consecutive world titles together. The smiling but tough-as-nails F1 auditor and the impassive but single-minded chief underlying his power. There's nothing they couldn't do.

You read it here first. ✖

This week in motorsport



WEBB/LAT

MONTOYA NEAR PACE ON INDYCAR RETURN

Juan Pablo Montoya lapped within a few tenths of a second of 2014 Penske team-mate Will Power in the first test of his IndyCar return at Sebring.

Despite not having driven an IndyCar since 2000 – the year he won the Indianapolis 500 – the

Colombian was quick from the outset of his two-day outing.

While Penske Racing president Tim Cindric described Montoya's first run as "impressive", the 38-year-old driver said his main focus had been on readjusting to single-seaters after six and a half years in NASCAR.

"The first run was really, really weird," said Montoya, who rated his performance as "an eight [of 10]".

"We're miles away from where I think I need to be," he added.

"That's kind of normal and it's happened to me before, so I know with time everything will be easier."

MONTOYA'S US SINGLE-SEATER CAREER

	Starts 41
	Wins 11
	Podiums 14
	Poles 14
	Laps led 1911



THOMPSON/GETTY

DI RESTA IN GANASSI LINK

Paul di Resta says he would consider a Chip Ganassi Racing IndyCar seat if his Formula 1 opportunities dry up. The drive became vacant when di Resta's cousin Dario Franchitti was forced to retire on medical grounds. "I wouldn't rule out anything; I've openly said I would discuss it with Dario," said di Resta, who could return to the DTM instead.



MURENBELD/LAT

Trois-Rivieres for Rallycross

Next year's World Rallycross Championship is expected to include an event in Canada as part of the Trois-Rivieres Grand Prix. Trois-

Rivieres is best known as the venue where an emerging Gilles Villeneuve beat F1 invitee James Hunt in a 1976 Atlantic race in the city (pictured).

FRIJNS EARNS AUDI DTM RUN

Former Sauber F1 reserve driver Robin Frijns tested a DTM car for Audi as part of a young-driver evaluation last week at Monteblanco. "DTM is one of the best options available to any driver, so it was nice to be invited along," Frijns (below) told AUTOSPORT. Formula 3 racers Jordan King and Harry Tincknell were among the seven other drivers invited to test.

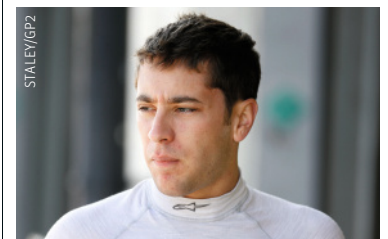

STALEY/CP2

For all the breaking news, visit AUTOSPORT.COM

ROSSI PIPPED BY SORDO

Dani Sordo denied Valentino Rossi back-to-back wins in the Monza Rally as he beat the seven-time MotoGP champion by 10 seconds in his Citroen.

"I had a lot of fun and won four stages," said Rossi, who drove an M-Sport Fiesta WRC. "Dani is someone who is really quick and is used to the car, so to fight with him is fantastic for me."



Strakka and Dome join forces

The British Strakka team and Dome have joined forces to make the Japanese constructor's LMP2 design a reality.

Strakka, the top LMP1 privateer at this year's Le Mans 24 Hours, has agreed a deal that will result

in it developing what will be known as the Strakka Dome S103 and racing it in the 2014 World Endurance Championship. It will also build and service customer examples from the UK. The first car should test in February.

In brief



DUTCH PHOTO AGENCY/LAT

MARCIELLO DOMINATES

Ferrari junior Raffaele Marciello dominated Formula Renault 3.5 testing at Aragon. The European F3 champion went quickest on all three days after testing for both Strakka and Arden Caterham. Carlos Sainz Jr was second fastest overall for DAMS.

ALESHIN TO INDYCAR

Mikhail Aleshin will become IndyCar's first Russian driver after signing a deal with Schmidt Peterson Motorsports for 2014. The 2010 Formula Renault 3.5 champion tested the team's Dallara-Honda for the first time at Sebring recently. He will partner IndyCar racewinner Simon Pagenaud next season.

LMP3 LAUNCHED

The Automobile Club de l'Ouest has created a new LMP3 class, which will run from 2015. The category will use a single make of engine, gearbox and tyre, but with open chassis regulations. It will replace the Formula Le Mans (LMPC) class in the European and Asian Le Mans Series.

ABT JOINS HILMER GP2

Daniel Abt will move from ART to Hilmer for next year's GP2 campaign. After vying for the 2012 GP3 title, the German had a poor debut season in GP2 this year with ART, claiming one top-five result and finishing the year 22nd in the standings.

LANCASTER FOR WEC

GP2 race winner Jon Lancaster will make his sportscar debut in this weekend's Bahrain World Endurance Championship finale. The 24-year-old Briton will drive the Greaves Motorsport LMP2 entry alongside Bjorn Wirdheim and Nissan GT Academy winner Wolfgang Reip.

FIRST FA1 SERIES TEST

The nascent Formula Acceleration 1 series, which utilises the old A1GP Lola-Zytek chassis, will test at Navarra on Friday and Saturday. While FA1 owns the cars, teams will operate them during the two-day run.



New Indy Lights car unveiled

Dallara has released the first images of the new Indy Lights car that will be introduced in 2015.

The IL-15, which is being introduced in a bid to boost grids, is expected to test for the first time in August 2014.

The current Dallara chassis – which has been in use since 2002 – will be upgraded next year prior to the switch.



NEUVILLE IN FIRST i20 TEST

World Rally runner-up Thierry Neuville got his first taste of a Hyundai i20 WRC on Saturday. The Belgian and co-driver Nicolas Gilsoul drove their new car for the first time in Alsace in preparation for January's Monte Carlo Rally, which will be their first competitive outing with the team.



Duval in Citroen WRC '14 talks

Former World Rally Championship event winner Francois Duval is in talks with Citroen about a return to the WRC next season. The Belgian, who last competed at the highest level in 2010, said: "There's a slight lack of good drivers in the WRC and I'm still young. The idea is to drive with Citroen – I don't see myself coming back to a car that is lower down the scale."

United Autosports targets BTCC

GT squad United Autosports is hoping to move into the British Touring Car Championship next year. The team, which narrowly missed out on the 2013 British GT crown, tested James Cole in an ex-Frank Wrathall Toyota Avensis at Donington Park last week.





Porsche recommends Mobil  and 

Please visit www.porsche.co.uk/mission2014 for further information.

**Every time we build a new race car,
we question every single part.
Except for one.**

Mission 2014. Our Return.

After more than a decade Porsche is returning to top-level racing in 2014 – to the FIA World Endurance Championship and its highlight, the 24 Hours of Le Mans.

Our strategy? The same that we follow when developing every Porsche – starting from the ground up and questioning every detail. We take nothing for granted. Except for the principle behind everything we've built for more than 60 years: Intelligent Performance.

Come along on our mission at porsche.co.uk/mission2014 and watch us develop our prototype first-hand.



PORSCHE

Derek Warwick

The inside line

The F1 veteran and BRDC chairman wants more reinvestment in the sport and extols the virtues of the current crop of talent

EBREY/LAT

The British Racing Drivers' Club and Silverstone are totally committed to finding the next Lewis Hamilton and Jenson Button. The biggest problem, like with many things, is that we don't have the budget to give out the kind of support we'd like, but I do believe we achieve massive credibility with the budget available. I also know that the drivers who become BRDC Superstars are proud to wear the badge and it gives them kudos within the racing fraternity and when they are in front of sponsors.

I'm sometimes disappointed that some people who are involved within motor racing don't give more back to the industry that has, in some cases, made them a fortune. Bernie Ecclestone is a good example. Bernie is British, he's a BRDC member so why doesn't he give something back to British drivers, create a foundation? What are other wealthy team owners and drivers doing to help put something back into our sport? Nothing.

McLaren is a big supporter of young drivers and has had various young-driver programmes, with Lewis Hamilton its biggest success so far, and more recently bringing Kevin Magnussen into its F1 race team. Ferrari is also a big supporter of up-and-coming talent, which is great because having the Prancing Horse behind you has great credibility.

Then you have the really big supporters like Red Bull, which has maybe 30 to 40 drivers on its programme including Sebastian Vettel. Without Red Bull, Formula 1 would be a poorer place.

raced anything bigger than Formula Renault that year, so GP3, F3 and upwards do not qualify. It's a shame this year that we couldn't have Dan Cammish, who won everything in British Formula Ford but unfortunately is 24.

The evaluation format is massively challenging for these young drivers. The six finalists all do a day with Porsche Human Performance to assess their fitness and half a day with Darren Turner's Base Performance Simulators, where they drive the Silverstone circuit plus a fantasy circuit to see how quickly they can learn a new track.

Then, during the two on-track days of evaluation, they drive McLaren MP4-12C road cars with 600-plus bhp to learn the Silverstone International circuit. And two of the drivers this year don't even have road licences!

Then they drive six identical Formula 2 cars with 425bhp. There are no set-up changes allowed on the first day in order to keep things simple and equal for everyone. They have two 40-minute sessions, followed by a 20-minute qualifying session with new tyres and no overboost.

This is followed by 40 minutes in a Mercedes DTM car, to give us an idea in of what they can do in a different formula, and 40 minutes in a McLaren GT3, with around 500bhp. And remember, one of the guys this year is only 16.

It's quite remarkable how quickly they cope with the different disciplines and how close they get to the times of the professional drivers we use as benchmarks. This year we had Christian Vietoris in the DTM car and Alexander

“I'm disappointed that some people involved in racing don't give more back to the industry”

In the UK, we do have Graham Sharp and the Racing Steps Foundation. Graham has shown such passion and commitment to bring drivers into motor racing who would not otherwise have had the chance. Without RSF support this year British drivers like James Calado, Oliver Rowland, Jake Dennis and Jack Harvey would not have been racing.

That's why the BRDC is so involved with young-driver programmes like the BRDC Rising Stars, BRDC Superstars and, of course, the McLaren AUTOSPORT BRDC Award, which has produced some amazing drivers over the years.

I'm chairman of the judges and, along with Ian Titchmarsh (BRDC director and commentator) Jason Plato (some racing driver I think!) Mark Williams (McLaren) Kevin Turner (AUTOSPORT) and Andrew Kirkaldy (former winner of the Award), we try every year to look at the best young British talent coming along.

The criteria is simple: the driver must not be older than 22 at the start of this season and he (or she) cannot have

Sims in the McLaren, both setting the base time for the young drivers to look at data.

On the second day we try to keep it solely for more F2 runs. The drivers get a 40-minute session and are now allowed to make changes to the car, followed by a 30-minute session in which they get to practise with the overboost. Then it's into qualifying with a specific number of overboosts, each one worth 75bhp, bringing the power up to 500bhp. It's interesting to see how they use the overboost and how they change the car. We have to remember also that these drivers are used to driving Formula Renault with less than 200bhp!

The six young drivers were very, very evenly matched so everyone needs to hold their breath on Sunday night. ☼



P60 THE AWARD AND THE 2013 FINALISTS

BRAZILIAN GP

THE RACE REPORT

QUALIFYING • TRACKSIDE VIEW • LAP CHART • DRIVER BY DRIVER • RESULTS

Vettel ends an F1 era in style

It was the last race for the V8s ahead of a winter of uncertainty, and Red Bull's four-time champion put in a performance entirely befitting his status as colossus of his time. **MARK HUGHES** reports

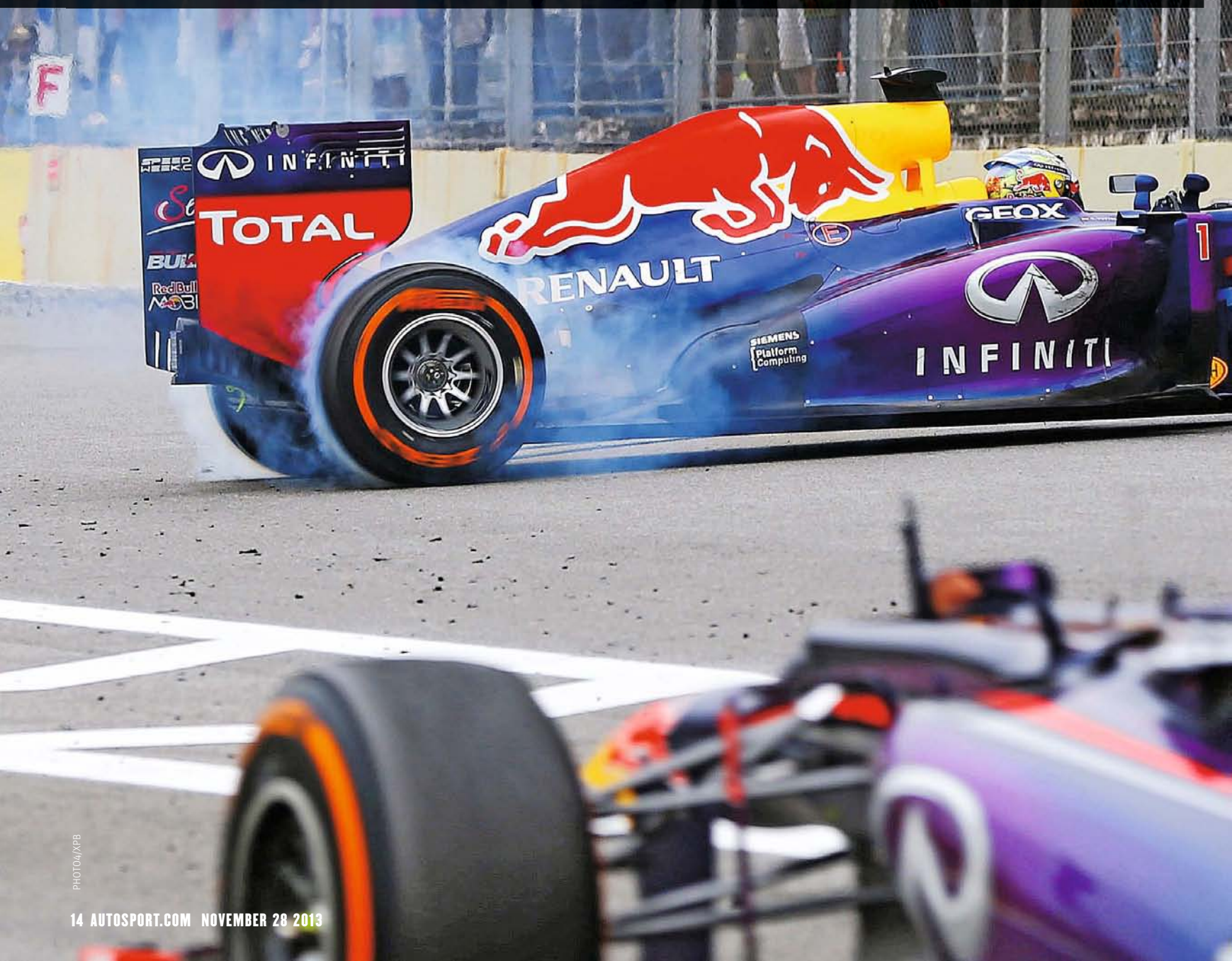

PHOTO:XPB

AT A GLANCE



"The drizzle never eased off, but it never properly rained. Vettel's reign, meanwhile, continued to the end of the formula"

BRAZILIAN GP

Interlagos

ROUND 19/19**LAPS 71****WINNER**Sebastian Vettel
1h32m36.300s**POLE POSITION**Sebastian Vettel
1m26.479s**FASTEST LAP**Mark Webber
1m15.436s**RACE RATING**★★★★★ Reasonably eventful,
but not an Interlagos classic**DRIVERS'
STANDINGS**

Vettel	397pts
Alonso	242pts
Webber	199pts





Vettel was unbeatable once Q3 finally started

QUALIFYING 14.00, 24.11.2013

16



Predictably unpredictable, the most capricious phase of the Interlagos weather coincided perfectly with the timing of qualifying. A wet-but-drying track at the start of Q1, then light showers, heavier showers, slightly easing again towards the end of Q1. Then heavy, heavier, heavier still as Q3 was due to start.

They could've started it at this moment; the track was still driveable, the puddles not so deep that the cars were going to aquaplane on their planks. Everyone could have got a couple of wet-weather-tyre laps in, before the track would have got ever wetter and all would have returned to the pits for the final 10 minutes or so. The chequered flag would have been hung out to an empty track.

Instead Q3 was delayed and delayed again – a very familiar Interlagos dance – for 40 minutes, after which the

darkest clouds had passed and the rivers subsided. They all set out on wets and several didn't even bother completing these laps before pitting for intermediates. For all that the ancient old place floods quickly, it dries fast too, the air temperature remaining moderately high, the wind stiff.

All this was just colour blurring past Sebastian Vettel's visor. Mix the circumstances as much as you like, the performance advantage was, if anything, only enhanced. It only became fully expressed in Q3 though, Seb doing as much as was needed to get through in the early laps, second in both Q1 and Q2 on the inters.

Red Bull's timing was impeccable at each time of asking in circumstances where it was very easy to get it wrong. Pretty much everyone got straight out there in Q1 knowing that the shower was on its way. In Q2 the track was wetter but relatively stable, making

timing less critical. But into Q3, on the now very wet but drying track, the team got Mark Webber and Vettel straight out there. They each did a single flying lap on wets before returning for inters and heading straight back out.

The crucial part of that Q3 sequence was that the early running gave them the opportunity of a flying lap, a cooling lap and another flying lap. Their chief competition – Nico Rosberg's Mercedes – didn't have time for that and was consigned to two consecutive flying laps, which meant he didn't get the benefit of a double KERS boost on both laps, only the first. It cost him around 0.4s in the long uphill drag from Juncao. But though Nico's lap was good for the front row, it trailed Vettel's best by over 0.6s. Even with the double KERS boost, in other words, he wasn't going to have stopped Vettel taking his ninth pole of the season. Either of Seb's hot laps would have been good enough, but his first one was marginally quicker.

The Red Bull was running plenty of downforce, the Mercedes somewhat less. Rosberg though looked much like the formidable wet-weather ace of Melbourne practice, consistently super-quick whenever he ran and comfortably eclipsing the second Red Bull of Webber, who just never felt the grip from the inters that Seb did and ended up over 1s adrift in fourth place, nudged out by an overachieving Fernando Alonso in the Ferrari.

If Vettel had a rival for star of the session it was surely Fernando. Although the timing of his runs meant

he faced the same KERS dilemma as Rosberg on the second of his laps, it was actually his first that counted. The follow-up lap could have been even faster regardless, but he braked just too late for Descida do Lago and ran out onto the painted run-off area. "That cost me almost eight tenths," he rued. Without that mishap, the second lap could even have eclipsed Rosberg's time. With that and the double KERS boost... Third was nonetheless a great performance. Felipe Massa in the sister car was 0.6s down and back in ninth.

Fifth fastest Lewis Hamilton was not at any point happy with the feel of his Mercedes in the wet. Just as in similar conditions of Melbourne practice, he was nowhere near as comfortable in the car as his team-mate, leaving him downcast. He'd hustled himself around fastest in Q1 but in the heavier rain ended up 0.5s off his team-mate. He suggested his feel for the mapping of the KERS and engine was not as good as it needed to be. The concept of an on-throttle blown-exhaust car (and its tendency to power-on understeer) may not be the most natural match for his preferred style of wet-weather driving. "I'm struggling to get to grips with how the car works in these conditions," he related. "It's getting better but there is still so much to learn."

Lotus didn't even bother to have Romain Grosjean complete his wet-tyred lap at the start of Q3 (which had been shaping up to be faster than Vettel's equivalent) but instead brought him straight in for inters and sent him



immediately back out. With hindsight it was too early. The thinking was that this could secure pole if the rain then got heavier. As it turned out, the track was still getting quicker when his inters were at their best and, by the time it was at its driest, his rubber was three laps old. It left him sixth and disappointed. Heikki Kovalainen, 11th, just failed to make it through to Q3 in the sister Lotus and was honest enough to admit that he just hadn't been quick enough.























The Toro Rossos had a particularly nice balance in these conditions and both Daniel Ricciardo and Jean-Eric Vergne made it through to Q3 (Vergne after a narrow squeak in which he almost fell out in Q1 after a badly-timed run). Once into the run-off, Ricciardo shaded his team-mate by hundredths, the pair seventh and eighth respectively.

'For all that the ancient old place floods quickly, it dries fast too'

Nico Hulkenberg scraped the Sauber through to Q3 but reckoned it was not as well balanced a car in the wet as it has recently been in the dry and it was all he could do to qualify it 10th, well adrift of his recent grid slots. Team-mate Esteban Gutierrez didn't get his Q1 lap together and failed to graduate.

Paul di Resta's Force India just shaded Valtteri Bottas's Williams for 12th on the grid, both feeling that was about the limit for their cars in the conditions. They were well ahead of their respective team-mates and in front of both McLarens. Sergio Perez, in the faster of the MP4-28s, was 14th to Jenson Button's 15th. But Sergio crashed out in Q2, getting out of the dry groove on the exit of Turn 5, running wide onto the slippery curve and spinning across the track into the wall. Running low-downforce settings, the cars were not warming up the tyres, meaning the dynamic pressures were wrong. Perez's crash put a driveshaft through the gearbox, necessitating a new unit and the associated five-place grid drop.

THE GRID

	2 ROSBERG MERCEDES 1m27.102s Medium		1 VETTEL RED BULL 1m26.479s Medium
	4 WEBBER RED BULL 1m27.572s Medium		3 ALONSO FERRARI 1m27.539s Medium
	6 GROSJEAN LOTUS 1m27.737s Medium		5 HAMILTON MERCEDES 1m27.677s Medium
	8 VERGNE TORO ROSSO 1m28.081s Medium		7 RICCIARDO TORO ROSSO 1m28.052s Medium
	10 HULKENBERG SAUBER 1m29.582s Medium		9 MASSA FERRARI 1m28.109s Medium
	12 DI RESTA FORCE INDIA 1m27.798s Medium		11 KOVALAINEN LOTUS 1m27.456s Medium
	14 BUTTON McLAREN 1m28.308s Hard		13 BOTTAS WILLIAMS 1m27.954s Medium
	16 MALDONADO WILLIAMS 1m27.367s Medium		15 SUTIL FORCE INDIA 1m28.586s Medium
	18 PIC CATERHAM 1m27.843s Medium		17 GUTIERREZ SAUBER 1m27.445s Hard
	20 VAN DER GARDE CATERHAM 1m28.320s Medium		19 PEREZ McLAREN 1m28.269s* Medium
	22 CHILTON MARUSSIA 1m28.950s Medium		21 BIANCHI MARUSSIA 1m28.366s Medium

* 5-place grid penalty

TRACKSIDE VIEW

Mark Hughes
GRAND PRIX EDITOR

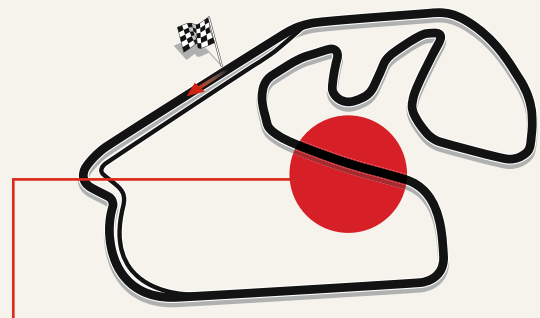

They plunge through the gloom to the bottom of the circuit, the depression of Turn 5, with the murky lake in the background and beyond that the blocks of flats, beyond which urban sprawl all the way to the horizon. Normal life is interrupted by the noise and madness of Formula 1, and Interlagos is ringing to the sound of screaming F1 V8s for the final time. A heavy black cloud hangs over the track on Friday morning and is in no hurry to move on, dropping a persistent heavy shower over the inters-shod cars accelerating up the short uphill straight between T5 and Ferradura, the blind-apex, steeply uphill right-hander, cars light over the crest and trying to spin their wheels, triggering a lift of the right foot and the gurgle of cylinder cut. Daniil Kvyat is 15 minutes into his run in the Toro Rosso and it looks like he's been doing it 15 years; smooth and confident, taking lots of momentum in, progressive and hard on the throttle. Romain Grosjean is smooth as honey and confident enough to stay out later than a wayward teenager before turning in, the Lotus's outside wheels even flirting with the treacherous outer white lines as the track begins to turn and he stays straight to get the geometrically perfect trajectory. Most others give that white line a half-metre of respect, beginning the turn earlier, like Valtteri Bottas who is carrying some confidence-inspiring understeer, but using that to enter the turn very fast, even is his exit is compromised. There's only the tiniest of straights afterwards, so he's probably not losing the time he's gained on the entry. In these conditions, changing by the lap, improvisation rather than data analysis is briefly king again.

'Daniil Kvyat is 15 minutes into his run; it looks like he's been doing it 15 years'

Grosjean flirts with disaster to get ideal geometric line

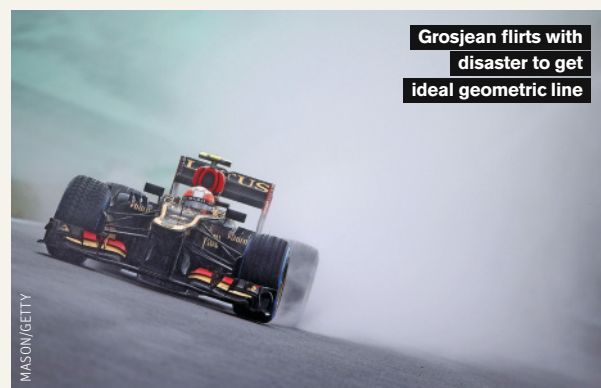



TW STEEL®

BIG IN OVERSIZED WATCHES



BE AMBITIOUS



OFFICIAL TIMING PARTNER

WWW.TWSTEELUK.COM



RACE 14.00, 24.11.2013



Sebastian Vettel did his victory donuts on-track after equalling Alberto Ascari's nine-race

consecutive world championship grand prix victory record. Red Bull team-mate Mark Webber drove his last-ever F1 slow-down lap with his helmet off. Felipe Massa came in from his own semi-donuts after his last race for Ferrari, still seething at the FIA for his drive-through penalty for repeatedly putting all four wheels inside the white pit-entry lines at the top of the hill.

As the last engine – Massa's – was shut down in the collecting area, Formula 1 bade farewell to the V8 formula. On that partly poignant and partly rebellious note, the sport signed off for the year and the forklifts got into immediate action in the mad, narrow confines of the Interlagos paddock. Drivers walked out into the foggy evening, some not knowing if they had a drive next year, some knowing they definitely did not, some wondering if their teams would still be in existence. With the title having been decided aeons ago, and so none of the normal Interlagos title-decider buzz, there was a strangely subdued vibe about the place as F1 headed into what may be a troubled winter.

By contrast, the opening laps were brilliantly vivid. Vettel was slow off the line – way too much wheelspin – and Nico Rosberg's Mercedes was past him

'It looked like Webber was having a ball, free and uninhibited in his final grand prix'

immediately. Both Ferraris were fast away, but Fernando Alonso's path to the right was blocked by Vettel and, as Fernando tried to switch left, he found that spot already occupied by the Mercedes of Lewis Hamilton. It was all Alonso could do to stave off Webber, who had the fast-starting Massa just behind him.

Ducking and diving through the Senna Esses, they snaked through the long Curva do Sol – though there wasn't much in the way of 'sol'. Grey cloud hemmed in the track, the surface of which was a chilly 25 degrees C. Rain was forecast at some stage soon – and that's how it felt, but at Interlagos you never know.

As Vettel tracked Rosberg closely, Alonso got a run on Hamilton and tried to sit it out with him at Ferradura, with Lewis prevailing. Fernando had another go a couple of corners later into the tight double-backs of the infield section. It was noticeable from Vettel's on-board footage that Rosberg's Mercedes was gripless in these early stages, and Hamilton reported the

same phenomenon in his scrap with Alonso. "The Ferraris are so much faster than us from cold," he said. "More traction, more grip, it even feels like more power."

At Juncao, the bottom of the long torquey drag up the hill, Vettel released the KERS charge he'd been saving up and got hard onto Rosberg's tractionless Merc, his gameplan being to do him in the slipstream onto the straight even before DRS was enabled a lap later. Up they swarmed at 190mph, and Vettel ducked out early onto that straight, opting for the outside before Rosberg could close him out. He was ahead by two hundredths of a second as they crossed the line and unchallenged into the Senna S.

A few lengths behind, Hamilton felt

literally powerless to stave off Alonso. He tried anyway, but the Ferrari was clean around his outside into the Senna S, Lewis then towing Webber along in his wake down to Descida do Lago. Mark held him in and compromised his exit as they screamed down the hill, then diving for the inside of the left-hand kink, side-by-side through there and grinding ahead up the straight until Ferradura demanded it was time to turn in. He did so with the Mercedes still partly alongside, presenting Lewis with no option but to concede his fourth place.

It looked like Webber was having a ball at this point, driving free and uninhibited in his final race, and he set off now in chase of Alonso, the Ferrari 1.48 behind Vettel as they crossed the ▶



Microsoft



FORZA | 5 MOTORSPORT

Forza Motorsport 5 is a cinematic automotive journey, starring the world's greatest cars and tracks. Built from the ground up to take advantage of Xbox One and the infinite power of the cloud, no game better delivers the wide-eyed thrill of racing.

Pre-order now. Available 22.11.13



Scan here for exclusive Xbox content



Xbox.com/Forza



Microsoft
Studios





HONE/LAT



DUNBAR/LAT

► line for the second time. Vettel was back in familiar territory, stamping his control on the race, judging his pace against the gap once he'd settled into a groove: "It was quite exciting in the first few laps, our first laps in the dry all weekend, finding the braking points and where the limit was."

On lap two there was a big cloud of white smoke on the exit of Juncao, heralding the end of Romain Grosjean's engine. The Lotus had just been passed for eighth by Nico Hulkenberg, but the Sauber wasn't its recent quick self here, with excessive understeer and a quickly-graining front left. He'd passed the slow-starting Toro Rossos off the grid and pulled gradually away from Daniel Ricciardo, but was soon a long way behind Massa.

The Toro Rossos were not enjoying the same driveable balance as in the wet of qualifying and Ricciardo would soon

give best to Jenson Button's McLaren, which conversely was behaving much better than the day before, when it had not been able to generate tyre heat. Team-mate Sergio Perez was making similar progress further back from his penalised grid position.

On the fourth lap, Alonso swept boldly past Rosberg down to Descida do Lago, and this battle carried some edge given that Mercedes and Ferrari were fighting for second in the constructors' championship. Nico was struggling with the balance of his car and badly lacked traction on this first set of tyres. Like everyone apart from Button and Esteban Gutierrez, Rosberg had started on the softer medium tyre, but the rears were not happy and soon he was easy meat for the charging Webber. Keen to get on with his chase of Alonso, Mark put a straightforward DRS move down the pit straight into the Senna S on

'Alonso was quick in all the awkward places and withstood Webber's attack'

Rosberg going into the seventh lap.

A light drizzle was now falling and team radars were warning of a full shower on its way, but no one knew quite when. Strategists began thinking in terms of trying to stay out long enough so that their stops could be dovetailed, if necessary, with a change to intermediates, and this pushed the race decisively towards a two rather than three-stop. The two strategies were theoretically quite evenly matched otherwise. Webber took a couple of tenths out of Alonso on the eighth lap and a chunky half-second next time, to put him right on the second-placed Ferrari's gearbox; Vettel by now was eight seconds up the road.

Alonso was quick in all the awkward places and withstood Webber's attack for the next four laps, but on lap 13 Webber saved all his KERS for the run up the hill out of Juncao and was able to sweep ahead down the inside into the Senna S. Alonso gave tenacious chase for a few corners, really making Webber work for it, but Mark wouldn't have been expecting anything less. It had taken 14 of the 71 laps for the Red Bulls to be running one-two.

About 10 seconds behind, Button ►



COATES/LAT

FRIDAY



DUNBAR/LAT

1006 Nico Rosberg is warned on his out-lap: "It's very slippery. Caution Turn 5, there's already been an incident there."

1015 Rosberg understeers off at T1.

1019 Lewis Hamilton loses the rear and spins in Turn 3. He keeps the engine running, backs up and rejoins.

1020 Jenson Button complains that "the car is very 'on the nose.'" He's told to return to the garage for a front-wing adjustment.

1031 Hamilton is told where he is slower than team-mate Rosberg, who is quickest overall: "Time lost to Nico is in Turns 6 and 7"

1040 Charles Pic is told: "You crossed the white line as you entered the pitlane. Try not to do that!"

1050 Sebastian Vettel is informed while running on the development tyres: "It's raining harder now and we have all the data we need, so box now."

1055 Romain Grosjean moans as he nearly hits **Giedo van der Garde** at Juncao: "We need to speak to the guys at Caterham! I almost hit him and ran off!"

1408 Max Chilton explains what the conditions are like: "There's a big puddle on entry into Turn 12, on the right side of the braking zone. You can push through the corners but you have to limit yourself down the straights."

1420 Jules Bianchi says he's "aquaplaning on the straights", before he is told to "stick with it".

1438 Rosberg's engineer tells him: "Ross [Brawn] says you're the only one dumb enough to be out there at the moment"

1518 Mark Webber is warned: "No KERS. KERS has failed."

1530 Vettel is told: "You need to calm down on this lap as you might run into the back of [Pastor] Maldonado otherwise."

1540 Hamilton admits he is struggling in wet conditions, in which there is "no hope for me".

Hamilton limps back after clash with Bottas



HONE/LAT

► finally nailed Hulkenberg for seventh at the second DRS zone, the pair having gone through the Senna S almost side-by-side. A couple of laps later Massa found a way past the struggling Rosberg at the same place, the second Ferrari now up to fifth and not so far adrift of Hamilton. Rosberg then noted how Massa was putting all four wheels inside the pit-entry lane, making a shorter, faster entry onto the pit straight, and he relayed this information over the radio for FIA race director Charlie Whiting's benefit. Ferrari was told to inform Massa to desist and he did so – for a while. Others were occasionally doing the same – Vettel, Webber and Button, to name three.

Once Webber got up to second, Vettel just matched his pace back to him, keeping the gap at around 10 seconds. If this were to be a straightforward race from here, Seb had it won. But this was early in the race to be assuming routine at Interlagos. That rain's threat was constantly delayed, but still there. For a two-stop strategy, you ideally needed to stay out another 10 laps or so. This phase of the race lacked the earlier zizz as the pack had unjumbled itself from the wet pecking order to that of the dry.

'Rosberg relayed that Massa was cutting the line – for Charlie Whiting's benefit'

Hamilton's stint was going quite nicely now that the Merc had achieved its correct tyre temperatures, way better than Rosberg's. Between laps 13 and 20 he kept the gap to Alonso constant at around 5s. But after 20 laps Alonso was feeling the rears beginning to fade and Hamilton was beginning now to catch him.

Massa had hit the same phase a couple of laps earlier. Since passing Rosberg he'd managed to pull out around 1s, and so Ferrari had brought him in on lap 19 and got him out again on another set of softer option tyres. Two laps later the team brought Alonso in, and had him fitted with a set of harder primes. Hamilton trailed down the pitlane a few seconds behind and he too received a set of primes. Alonso rejoined the track in front of Massa, Hamilton behind. Felipe's new-tyred laps while Hamilton had trailed around on his old Pirellis for an extra three laps



DUNBAR/LAT

had leapfrogged Massa over the Mercedes. Which rather spoilt Hamilton's plans of catching Alonso.

When the Red Bulls stopped, there was a delay on the left-front of Webber's car, costing him around 3s. Coupled with Alonso's stop two laps earlier, this allowed the Ferrari to scream past as Mark left the pit exit. That's all it took for Fernando to snatch an opportunity, but Webber was able to repass almost immediately into the Senna S, with Alonso coming back at him but Mark prevailing and then pulling away.

Hamilton's pursuit of the Ferrari pair got complicated further when a message was relayed from race control that Massa should serve a drive-through penalty for having once more breached the rule regarding placing all four wheels inside the pit-entry lines as he crested the top of the hill. Massa stayed out for the maximum permitted three laps, during which time he slowed, thereby backing Hamilton further away from Alonso. Even in his final grand prix for a team that's not renewed his contract, Felipe appeared still to be taking one for that team. Or was he?

Before being informed of the penalty, Massa had been lapping in the high 1m17s. His three laps after being told of

it were 1m18.1s, 1m18.4s and 1m18.3s. "He's backing off," complained Hamilton, who had been told by his crew not to attack him. But Massa's subsequent pace after coming in for the penalty on lap 34 – and giving a few hand gestures along the way – was mid-1m18s, with clear space ahead of him. So perhaps his tyres had simply gone again – but it was rather early for that to have happened, just 10 laps after his first stop.

It all meant that by the time Massa pitted out of his way, and rejoined way back behind Perez, Hamilton's deficit to Alonso had grown to seven seconds. Hamilton was able to reduce this by a couple of seconds before they each made their second stops 13 laps later. It wasn't enough. Alonso, meanwhile, had fallen around 6s off the back of Webber, who in turn was almost 13s down on the relentless Vettel. Still the drizzle came on and off, still the arrival of the full rain was postponed, still everyone tried to stay out as long as possible just in case the rain should arrive.

McLaren took advantage of this by bringing in Button from just behind fifth-placed Rosberg, so as to undercut him. Mercedes left Nico out for a further couple of laps, not wanting to risk him running out of rubber at the end, and Jenson duly went by before

Impressive Hulkenberg was in points again for Sauber, taking eighth



COATES/LAT

SATURDAY



Webber homes in on Alonso and Rosberg



Vergne and Maldonado came together in midfield



Gutierrez does battle with Vergne



Bianchi's Marussia won tail-end fight

the Mercedes rejoined. Perez pitted on the same lap as Rosberg and rejoined just behind.

Going into lap 47 the destiny of this race almost turned. Valtteri Bottas had pitted his Williams three laps earlier, rejoining just behind Hamilton but a lap down. On his new option tyres Bottas was immediately lapping almost 1s per lap faster than Hamilton, whose rubber was 20 laps old, and he went to unlap himself from the Mercedes, using DRS down the pit straight and opting for the outside line into Descida do Lago, but still not fully alongside as they got there. "I didn't realise he was still

there," said Hamilton. "He was a lap down and trying to go around the outside." Lewis steered right to take up the normal approach to the turn, and his right-rear touched the left-rear of the Williams, instantly ripping off Bottas's tyre and spinning the Williams to a stop. Hamilton's tyre deflated and delaminated, and he crawled back to the pits.

Was retrieval of the Williams going to involve a safety car? It was a crucial call, and for Red Bull there were only a few seconds to make it as Vettel was just coming up to Juncao at the bottom of the hill before the rise to the pitlane

— about 12 seconds away. "If it had gone under a safety car," said team boss Christian Horner, "then Seb could have got caught behind it at the beginning of the lap while everyone else got to pit for free. It would have cost Seb about 20 seconds." Which would've dropped him back to third — and put Webber, in his final grand prix, in front!

"They told me to box if I could," said Seb. "I had enough time, but I think it was a bit on the limit for the team to be ready." The team issued the same instruction to Webber 13s back. In theory there was just enough time to get Vettel in, serviced and under way ▶



COATES/LAT

1106 Vettel is warned: "It looks pretty tricky out there in a straight line and there'll be lots of aquaplaning."



1115 Button reports: "There's some tyre shuddering, perhaps an imbalance?" His engineer asks him to pit for further checks.



1121 Hamilton's engineer tells him: "Water level is higher than the last run, exercise caution."



1134 Nico Hulkenberg asks: "Do you think this will get better? It's oversteering."



1137 Vettel runs wide off the track at Turn 4 and recovers.

1148 Hulkenberg's handling woes continue: "On some corners it's massively snappy, on others it's understeering."



1157 Jean-Eric Vergne says: "The car is pulling massively to the left." He's told that he has high brake temperatures to the left of his car.



1400 Q1 starts in intermediate conditions but with more rain expected. Thirteen cars hit the track immediately.

1404 Fernando Alonso reports: "There's a bit of rain, but a dry line is appearing."



1410 Vergne questions his team's decision to leave his running late: "Why did we wait?"



1442 Sergio Perez shunts heavily in a last-ditch attempt to make Q3 exiting Turn 5.

1447 Start of Q3 is delayed because of track conditions.

1530 Q3 finally gets underway, with Webber and Vettel heading out first.

1533 Alonso is asked: "You think the track will be OK for inters in a couple of laps?" He replies: "Yes, it'll be OK."



1543 Vettel celebrates: "Unbelievable, we didn't need a second attempt - we did it in the first one! Olé!"





Hang on Mark – you'll need that in sportscars



Fourth for Button was McLaren's best of 2013

'Seb added his name to a Brazilian flag presented to Webber, who said something about a PR stunt – honest to the end'

► just as Webber was arriving. But in the confusion one of the tyres intended for Vettel was in fact Webber's, and this took a few seconds to sort. It cost Vettel around 11s, five of which included Webber stationary behind him. Alonso pitted too and made up all that time on them. Vettel and Webber were now on primes, Alonso on options. Vettel's lead had been cut to 7s and Alonso lay right on Webber's tail once more.

As it turned out, there was no safety car... Hamilton limped slowly in for a new set of tyres and was then informed he would have to serve a drive-through for causing the accident. By the time he'd suffered all those delays he was outside the points. Vettel set about extending his lead once more, Webber railed against it and set the race's fastest lap as he did so and gradually eased out his advantage over

THE RACE LAP BY LAP

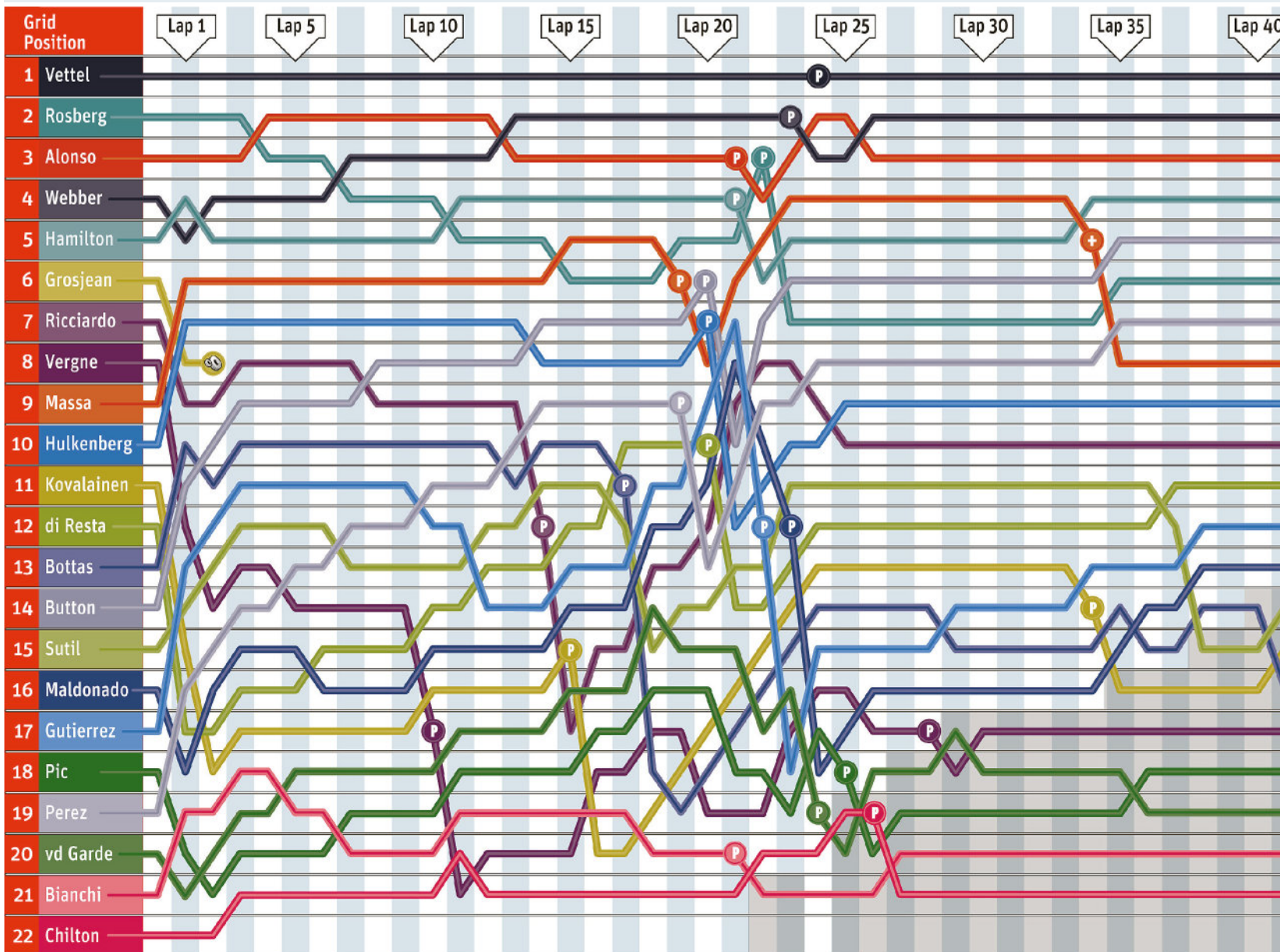



Massa ends his lengthy Ferrari career in style

Alonso. Button had now slotted into the place where Hamilton, Massa and Grosjean would have been but for their misadventures, and so lay fourth, but with enough pace to remain in front of Rosberg, who was having to withstand constant pressure from Perez. The penalty-delayed Massa was some way distant from that, in seventh, but pulling steadily away from Hulkenberg, while Hamilton caught and passed

Ricciardo for ninth. Mercedes retained its second place in the constructors' championship over Ferrari.

Fog lay just beyond the boundaries of the circuit and the drizzle never did ease off. But nor did it properly rain. Vettel's reign, meanwhile, continued right to the very end of the formula. As the top three waited for the podium ceremonies there was an obvious warmth between Alonso and Webber.

Vettel stood to one side, with Horner.

Seb was magnanimous in his words about his retiring team-mate and later added his name to those of the other drivers to a Brazilian flag that was presented to Webber. Mark looked on unimpressed, said something about a PR stunt — straight, honest and fast right to the very end. But he's been up against a phenomenon these past five years. ☘

SUNDAY



1111 Perez hit with a five-place grid penalty for changing his gearbox, a consequence of his qualifying crash.

1333 Felipe Massa gets a standing ovation by the Ferrari team as he leaves the garage to go to the grid.

1359 Hamilton is told before the start: "On tyre saving, we expect to be doing some management with the front right. Turns 11, 4 and then 12 in that order."

1402 On the formation lap, Webber reports: "My visor is off mate. My visor is off."

1407 Grosjean asks: "What, is this seventh gear? It's a disaster!" His Renault engine then detonates.

1417 Rosberg is told: "If you have problems with the tyres, then don't hold up Lewis. If they're coming back, then push." Hamilton soon passes him.

1444 Massa is warned: "Please watch the pit entry. You can't cross it with all four wheels." He is then hit with a penalty.

1450 Button is told: "Massa's penalty was for crossing the white line, so we must make sure we don't do that"

1456 Webber is told: "Stay away from the white line at pit entry. We'll get no warnings. We'll get no more warnings. Pace is good, you're pulling away from Alonso."

1508 After contact with Hamilton, Valtteri Bottas says: "He turned in on me!"

1512 Hamilton is told he has to serve a drive-through penalty for the collision: "I'm afraid Lewis, we have a drive-through. We want to get it done as soon as possible." He responds: "Was that my fault?"

1513 Van der Garde given a drive-through penalty for ignoring blue flags.

1539 Christian Horner tells Webber: "It's been brilliant working with you. You can be proud of what you have done."

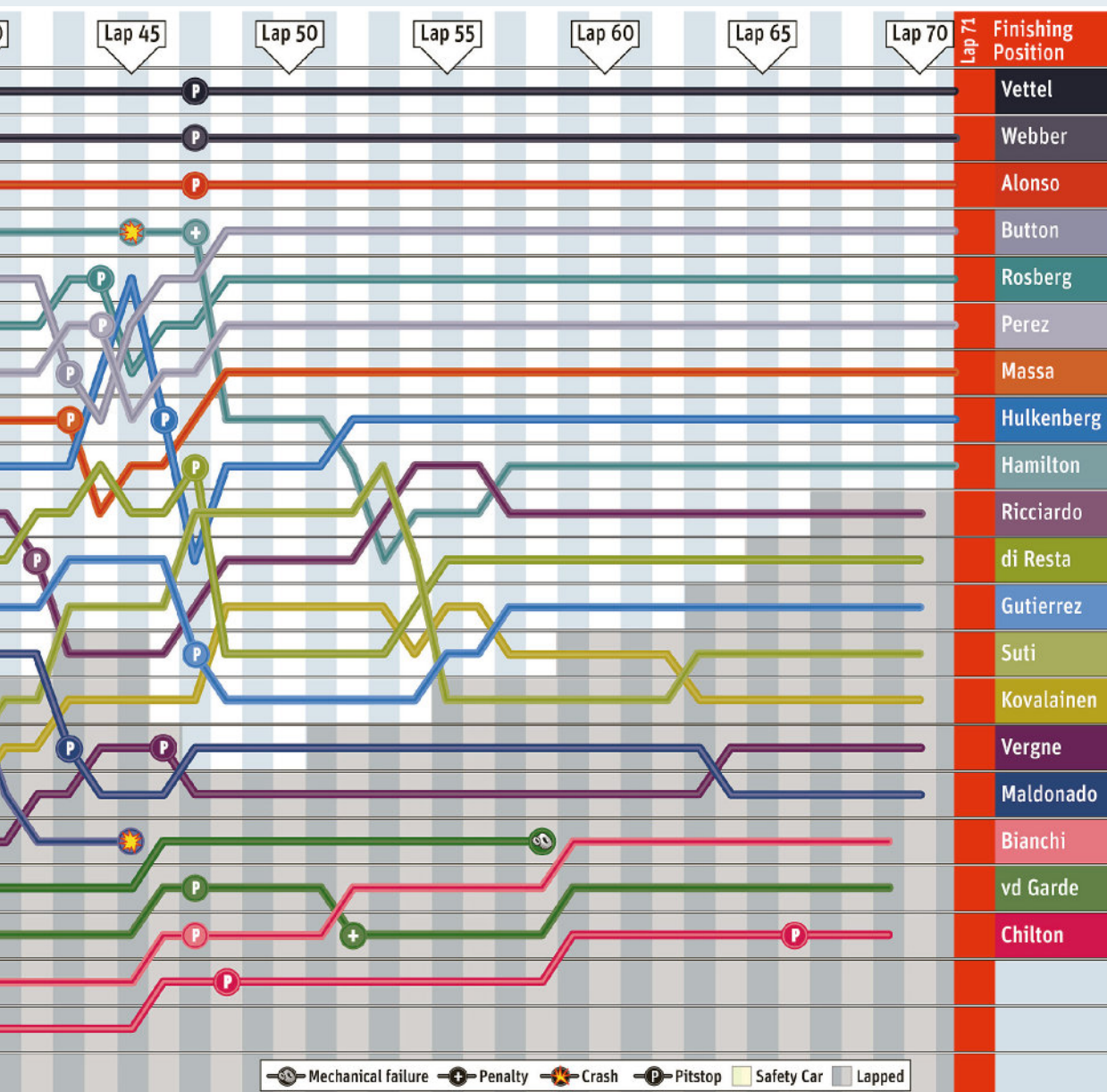

TEE/LAT

TEAM BY TEAM

RED BULL



Perfect one-two in title-year finale

1
10/10
Event rating

CIANFLONE/GETTY

SEBASTIAN VETTEL
Red Bull-Renault RB9-03
Start: 1st; Finish: 1st
Strategy: 2 stops
(medium/medium/hard)



Vettel demonstrated his wet-weather prowess in qualifying, nailing not one but two laps quick enough to give him pole by six tenths. Only in Malaysia and India was his qualifying advantage greater. Although his getaway was so-so, he wasted no time in taking the lead from Rosberg, doing so without the help of the DRS at the end of lap one. As usual, he then controlled things perfectly to nail his ninth victory in a row.

2
8/10
Event rating

THOMPSON/GETTY

MARK WEBBER
Red Bull-Renault RB9-04
Start: 4th; Finish: 2nd
Strategy: 2 stops
(medium/medium/hard)



Qualifying was disappointing as Webber didn't get the best out of the intermediate rubber during Q3. This was costly, because after losing a place to Hamilton off the start, he comfortably picked off both Mercedes and Alonso by lap 13 but was, by then, 10 seconds off Vettel. Yes, the German was cruising, but Webber showed signs of the pace needed at least to make a fight of it. One of his best races of 2013.

FERRARI

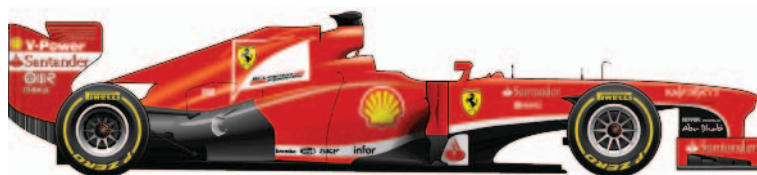

Alonso is the best of the rest again

3
9/10
Event rating

XPBLAT

FERNANDO ALONSO
Ferrari F138-298
Start: 3rd; Finish: 3rd
Strategy: 2 stops
(medium/hard/medium)



Wet qualifying was good news for Alonso, but a mistake at Turn 4 on his fastest lap cost him, by his own admission, around 0.8s and a place on the front row. His race performance is hard to fault, as he got up to second after passing Rosberg early on but was powerless to stop Webber (twice) overtaking him for the place. All things considered, the final gap of 19 seconds to Vettel suggests Alonso did what he could.

4
6/10
Event rating

XPBLAT

FELIPE MASSA
Ferrari F138-298
Start: 9th; Finish: 7th
Strategy: 2 stops
(medium/medium/hard)



Massa was desperate for his final start for Ferrari to end on the podium, and he knew he could count on Alonso's help to achieve it. Qualifying was poor as he struggled in the wet conditions, but in the race he was set for fourth place – and presumably third once Alonso let him past – when he was hit with a drive-through. Massa was unimpressed, but given the team had warned him, it was an avoidable penalty.

RED BULL SPLITS ITS RIMS...

➔ Red Bull's wheels still feature a measure of aero scavenging effect, even though the method of doing this through the centre has been banned.

GARY ANDERSON The holes can't go through axles now, but can still go through the wheel itself – and you can

still use that as a fan to accelerate the airflow through. Red Bull has split the wheel into outer and inner circles and without it the brakes would work less efficiently because all the air would be taken to the outside, while the middle would lose suction and stall. By doing this the middle bit remains energised.

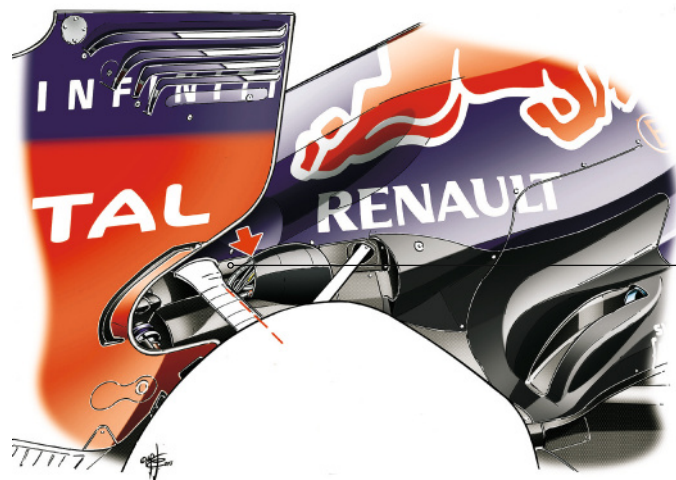
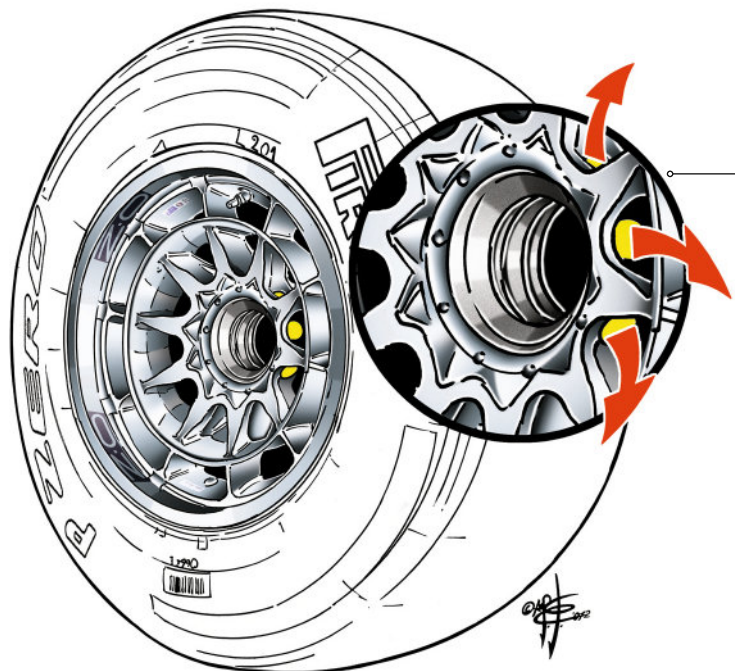

...AND RUNS SMALL REAR DISCS

➔ Red Bull used smaller rear discs at Interlagos and had them fully instrumented on Friday.

GARY ANDERSON Normally you run the same size discs and calipers front and rear, but because of the weight transfer you have more braking effect on the front than the rear. The load at the tyre is what you can brake with, so you work to that with the hydraulic brake-bias bar. You end up with 58 per cent front/42 per cent rear, which is inefficient and is what causes all the front lock-ups you see as the KERS finishes harvesting. The way the

pressures build up between front and rear is different – as is the way the pressures diminish. The best way to address that is to equalise the pressures. One way to do that is to use smaller rear discs and calipers and run 50/50 brake distribution. With KERS now doing some of the braking – and that increasing next year – teams will be allowed active brake balance, which I think will lead to smaller rear discs. Red Bull will have been gathering data for that, so it can accurately measure pressures at the calipers themselves rather than at the master cylinders.

McLAREN AND FERRARI

RIVAL SUSPENSION COMPARED

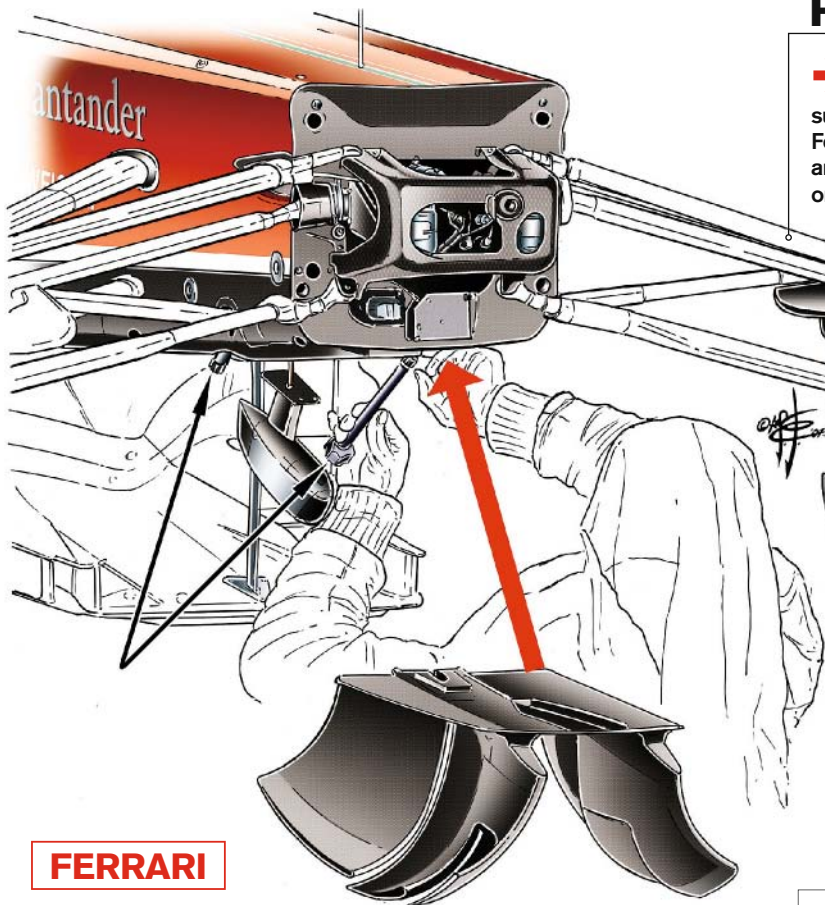

➔ Access for adjustment of McLaren's front pull-rod suspension is rather better than Ferrari's. McLaren has sited its brake and clutch master cylinders on a clip-on system on coiled cables that can be

moved to the side for access. Ferrari needs to remove lower bodywork and access the suspension from beneath. The McLaren drawing shows the torsion bar (1), anti-roll bar (2), steering link (3), third damper (4) and wheel tether (5).

GARY ANDERSON The way you rotate the rocker on pull-rod suspension is tricky. You can rotate it clockwise/anti-clockwise or vertically. McLaren can pull the torsion bars out of the front, while Ferrari has to remove them from below. Space constraints are driven by the angle of the rocker, which determines how much the suspension stiffness rises as it is compressed, and the size of damper and third damper. McLaren's solution is more practical than Ferrari's.

McLAREN

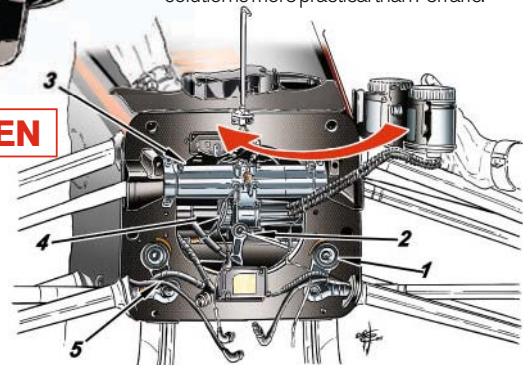

FERRARI

McLAREN

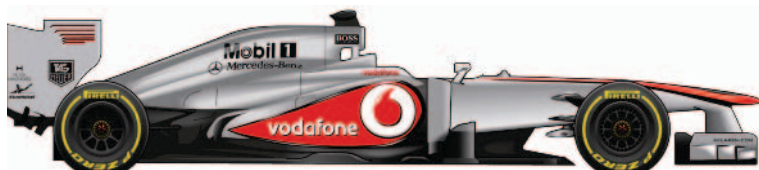

Duo charges to double points finish

LOTUS



Forgettable finale for British squad

5
9/10
Event rating



XPB/LAT

JENSON BUTTON
McLaren-Mercedes MP4-28-04
Start: 14th; Finish: 4th
Strategy: 2 stops
(hard/medium/medium)



Button showed good pace at times in qualifying, but struggled to get the intermediates to work on a slightly damper track. Once the race was underway he drove superbly. His pace was consistently good, he made passes when he needed to and thanks to Massa's penalty ended up a season-best fourth. It was a classic, beautifully measured Button drive.

6
7/10
Event rating



XPB/LAT

SERGIO PEREZ
McLaren-Mercedes MP4-28-02
Start: 19th; Finish: 6th
Strategy: 2 stops
(medium/medium/hard)



Shaded Button during Q2, in which both struggled on intermediate rubber, but a needless crash exiting Turn 5 damaged his gearbox and earned him a five-place grid penalty for its change. Made very rapid progress during the first stint – it took only 13 laps to hit the points. Finished seven seconds behind Button, making you wonder what might have been possible.

7
5/10
Event rating



PENNINGTON/GETTY

HEIKKI KOVALAINEN
Lotus-Renault E21-05
Start: 11th; Finish: 14th
Strategy: 2 stops
(medium/medium/hard)



Kovalainen was solid if unspectacular in rain-hit qualifying, but was disappointed not to make it into Q3. His race was defined by what he admitted was a bad start and a struggle to build tyre temperature in the dry. Dropped to 17th by the end of lap two and made little progress in recovery, finishing well off the points-finish he expected. A step backwards from Austin.

8
6/10
Event rating



XPB/LAT

ROMAIN GROSJEAN
Lotus-Renault E21-04
Start: 6th; Finish: DNF
Strategy: retired
(medium)



There is little material to judge Grosjean on from the weekend. His qualifying result was disappointing, partly as a result of Lotus perhaps gambling too early on a switch to intermediates, but his lap could have been better. In the race, he dropped to eighth at the start and struggled for pace thanks to tyre temperatures when his Renault engine lunched itself near the end of lap two.

MERCEDES



Points table runner-up slot secured

9

7/10
Event rating



NICO ROSBERG
Mercedes F1 W04/03
Start: 2nd; Finish: 5th
Strategy: 2 stops
(medium/hard/medium)



Practice suggested Rosberg had the pace to challenge Vettel in the wet, but although he probably should have been a little quicker in qualifying, it would have been a big ask to make up the 0.6s deficit. After leading from the start, he was powerless to keep Vettel at bay and dropped to sixth while battling rear-tyre degradation. But he drove an intelligent and conservative, if unspectacular, race from there to secure second in the championship for Mercedes.

10

6/10
Event rating



LEWIS HAMILTON
Mercedes F1 W04/04
Start: 5th; Finish: 9th
Strategy: 2 stops
(medium/hard/hard)



Was frank about his struggles to get on top of the Mercedes in wet conditions this season and always looked second best to Rosberg. But Hamilton came into his own in the race and, after passing his struggling team-mate early on, was shaping up for fourth place. Until, that is, he drifted over on Bottas's Williams. While the penalty was perhaps harsh for an honest and small error, Hamilton was at fault for the completely needless collision.

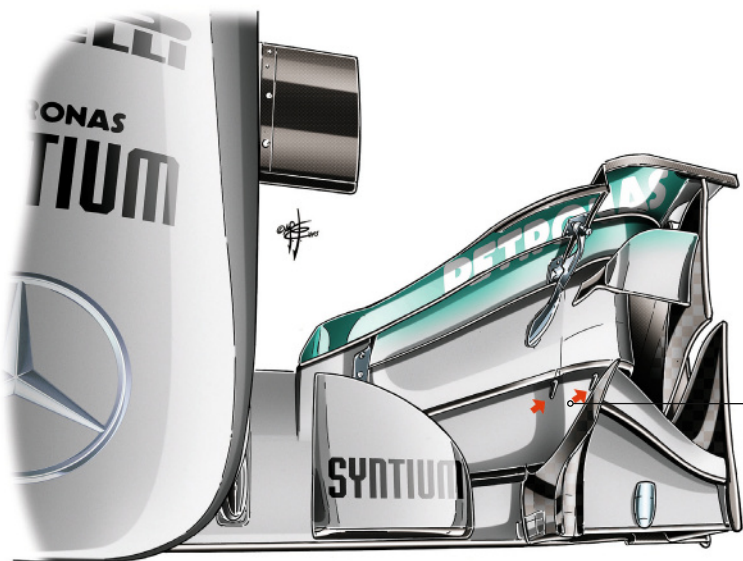

MERC ADDS BITE TO ITS WING

➔ Mercedes recently added these two 'teeth' to the underside of one of the front wing elements.

GARY ANDERSON Red Bull started this concept. They sit in front of where the splitters go across the slot gap. Beneath the wing it's divided by splitters into sections. Having these teeth here will separate the airflow before it gets into the slot gap. The air speed through there is very high so having the splitter across it induces airflow separation that these teeth will minimise by getting the air to flow down the sides better. They are curved in shape and the bits of rubber thrown up by the tyres will want to wrap themselves around them because they get sucked into the slot gap. By getting wrapped around there they will go above the wing and cause much grief.

SAUBER



Hulkenberg adds to his points tally

11

7/10
Event rating



NICO HULKENBERG
Sauber-Ferrari C32-03
Start: 10th; Finish: 8th
Strategy: 2 stops
(medium/medium/hard)



On a difficult weekend for Sauber, Hulkenberg wasn't able to repeat the heroics of some of his recent outings. But considering the understeer problem he battled for much of the weekend, he did a good job to make Q3 and pick up four points. Certainly didn't have the pace to beat any of the cars ahead of him and kept Ricciardo at arm's length, which adds up to a decent weekend's work.

12

7/10
Event rating



ESTEBAN GUTIERREZ
Sauber-Ferrari C32-04
Start: 17th; Finish: 12th
Strategy: 2 stops
(hard/medium/medium)



Not for the first time he showed a very handy turn of pace in wet conditions – at least he did until it really mattered as he failed to post a quick enough lap to escape Q1, either in the first half of the session when the conditions allowed or late on when Vergne was able to do so. That qualifying failure was doubly painful given that, without it, he certainly had the race pace to have scored points.

FORCE INDIA

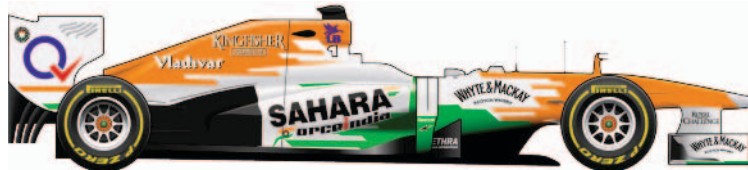

Problems keep pair out of top 10

14

7/10
Event rating



PAUL DI RESTA
Force India-Mercedes VJM06-04
Start: 12th; Finish: 11th
Strategy: 2 stops
(medium/medium/hard)



What's very likely to be di Resta's final outing for Force India was a good one, although a poor start probably cost him a point. Slipped to 17th off the line and while he was able to make his way through the lower midfield, he couldn't quite get ahead of Ricciardo in the closing stages. Deserves credit for the progress he made after that bad start, although with a stronger getaway he could have had a very different race.

15

6/10
Event rating



ADRIAN SUTIL
Force India-Mercedes VJM06-03
Start: 15th; Finish: 13th
Strategy: 3 stops (medium/medium/hard/medium)



A difficult weekend for Sutil, who was unable to put in a strong lap early in Q2 and then had a later attempt to improve stymied by Perez's crash. In the race, tyre wear was a big problem and he ended up having to make three stops, which effectively eliminated him from contention for the final point. Did recover some ground late on, but was 10 seconds off the pack disputing 10th place at the finish.

WILLIAMS



No final heroics at end of grim year

16
5/10
Event rating



CIANFLONE/GETTY

PASTOR MALDONADO
Williams-Renault FW35-03
Start: 16th; Finish: 16th
Strategy: 2 stops
(medium/medium/hard)



It was no great surprise to see Maldonado's Williams career ending in a whimper. After failing to pull a good enough lap out of the bag in the best conditions of Q1, he was knocked out in the first segment of qualifying. In the race, there wasn't much hope of points and Maldonado has to take the lion's share of responsibility for the clash with Vergne that led to him spinning as he chopped across the front of the Toro Rosso.

17
8/10
Event rating



XPB/LAT

VALTTERI BOTTAS
Williams-Renault FW35-01
Start: 13th; Finish: DNF
Strategy: retired
(medium/hard/medium)



After the heroics of Austin, Bottas's weekend seemed a little disappointing, but the reality is the Williams wasn't quite as well suited to Interlagos. His qualifying effort was fine given the conditions, but in the race he battled hard to stay in touch with the points fight after running 10th early on, but never had a chance of scoring. Eliminated after Hamilton drifted into him on the straight, which earned the Mercedes driver a penalty.

TORO ROSSO



Departing Ricciardo shines again

18
7/10
Event rating



XPB/LAT

JEAN-ERIC VERGNE
Toro Rosso-Ferrari STR8-03
Start: 8th; Finish: 15th
Strategy: 3 stops
(medium/hard/medium/hard)



Vergne usually goes well in the wet, but came perilously close to being eliminated in Q1 until he saved himself with a good effort late on in tricky conditions. Went on to qualify well, just behind Ricciardo. Things took a turn for the worse at the start as Vergne plummeted to 12th and then, a lap later, 14th. That set the tone for a disappointing race, but there was little he could have done to avoid the first-corner clash with Maldonado.

19
9/10
Event rating



XPB/LAT

DANIEL RICCIARDO
Toro Rosso-Ferrari STR8-01
Start: 7th; Finish: 10th
Strategy: 2 stops
(medium/hard/hard)



Ricciardo is famed for his qualifying specials, but at Interlagos it was his performance on Sunday that really shone. The Toro Rosso was again a tricky car in race conditions, but after running as high as eighth early on, the Australian faced a tough rearguard action to hang on to 10th place. He did so very well, keeping di Resta and Gutierrez at bay to nick a final point that he never seemed to have a firm grasp on.

CATERHAM



Pic retirement spoils bid to pip rivals

20
6/10
Event rating



XPB/LAT

CHARLES PIC
Caterham-Renault CT03-06
Start: 18th; Finish: DNF
Strategy: retired
(medium/hard)



Did a better job than his team-mate in wet qualifying, and did what he needed in the race to keep the Marussias behind him until he was forced to retire with a suspension problem. That said, he was passed by van der Garde early on and was destined to finish behind the Dutchman had his team-mate's penalty and his own retirement not intervened. A solid but unspectacular end for Pic, whose F1 future is in serious doubt.

21
7/10
Event rating



XPB/LAT

GIEDO VAN DER GARDE
Caterham-Renault CT03-04
Start: 20th; Finish: 18th
Strategy: 2 stops
(medium/medium/hard)



The qualifying result was disappointing, half a second off Pic, although he did at least keep the Marussias behind which, with 10th in the constructors' championship at stake, was his main brief. Got ahead of Pic early on in the race and would have been able to beat both his team-mate and the Marussias but for a penalty for ignoring blue flags, partly thanks to no warning from the pitwall. Overall, a decent end to the season.

MARUSSIA

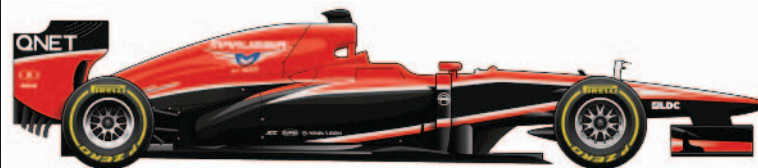

Lucrative P10 in teams' war secured

22
6/10
Event rating



XPB/LAT

JULES BIANCHI
Marussia-Cosworth MR-02-02
Start: 21st; Finish: 17th
Strategy: 2 stops
(medium/hard/hard)



Could have split the Caterhams, or even beaten them both, in qualifying but for a mistake that cost around half a second in the final sector on his best lap. Made a good start to get into the lead of the Caterham/Marussia battle, but it wasn't long before van der Garde overtook him while he struggled with the tyres. His race pace was fine, although beating van der Garde was down to the Dutchman's penalty.

23
5/10
Event rating



XPB/LAT

MAX CHILTON
Marussia-Cosworth MR-02-03
Start: 22nd; Finish: 19th
Strategy: 3 stops (medium/medium/hard/medium)



Wasn't on Bianchi's level, although the eventual gap to his team-mate (55s) was exaggerated by the fact that Chilton had to make an extra pitstop with a tyre vibration. Brought the car home a distant last, which while a little disappointing did earn him the record for number of race finishes for a rookie. A slightly underwhelming end to a season in which Chilton did better than his detractors are willing to recognise.

BRAZILIAN GP RESULTS



THOMPSON/GETTY

PRACTICE 1: Friday

POS	DRIVER	TIME
1	ROSBERG	1m24.781s
2	HAMILTON	1m25.320s
3	VETTEL	1m25.387s
4	BUTTON	1m25.391s
5	ALONSO	1m25.593s
6	WEBBER	1m25.797s
7	PEREZ	1m25.946s
8	KVYAT	1m26.064s
9	KOVALAINEN	1m26.133s
10	HULKENBERG	1m26.232s
11	MASSA	1m26.248s
12	GUTIERREZ	1m26.326s
13	GROSJEAN	1m26.570s
14	VERGNE	1m26.593s
15	SUTIL	1m27.115s
16	BOTTAS	1m27.269s
17	MALDONADO	1m27.358s
18	CALADO	1m27.436s
19	VAN DER GARDE	1m28.107s
20	PIC	1m28.199s
21	BIANCHI	1m30.004s
22	GONZALEZ	1m32.646s



PRACTICE 2: Friday

POS	DRIVER	TIME
1	ROSBERG	1m27.306s
2	VETTEL	1m27.531s
3	WEBBER	1m27.592s
4	KOVALAINEN	1m28.129s
5	HAMILTON	1m28.147s
6	VERGNE	1m28.405s
7	MASSA	1m28.540s
8	HULKENBERG	1m28.560s
9	RICCIARDO	1m28.739s
10	GROSJEAN	1m28.891s
11	ALONSO	1m28.928s
12	GUTIERREZ	1m29.049s
13	DI RESTA	1m29.174s
14	MALDONADO	1m29.717s
15	SUTIL	1m29.783s
16	BOTTAS	1m30.425s
17	PEREZ	1m30.748s
18	BIANCHI	1m31.061s
19	VAN DER GARDE	1m31.118s
20	PIC	1m31.165s
21	CHILTON	1m31.211s
22	BUTTON	1m31.770s

PRACTICE 3: Saturday

POS	DRIVER	TIME
1	WEBBER	1m27.891s
2	GROSJEAN	1m28.185s
3	KOVALAINEN	1m28.595s
4	BOTTAS	1m28.600s
5	HULKENBERG	1m28.830s
6	VERGNE	1m28.921s
7	GUTIERREZ	1m29.215s
8	MALDONADO	1m29.686s
9	DI RESTA	1m29.736s
10	SUTIL	1m29.913s
11	HAMILTON	1m29.980s
12	RICCIARDO	1m29.988s
13	BIANCHI	1m30.635s
14	PIC	1m30.837s
15	CHILTON	1m30.972s
16	VAN DER GARDE	1m31.154s
17	VETTEL	1m31.857s
18	PEREZ	1m32.731s
19	ROSBERG	no time
20	ALONSO	no time
21	BUTTON	no time
22	MASSA	no time

FRIDAY TESTERS

	1	KVYAT	1m26.064s
	2	CALADO	1m27.436s
	3	GONZALEZ	1m32.646s



ETHERINGTON/LAT



GILHAM/GETTY

Weather: Damp

Weather: Wet

Weather: Wet

QUALIFYING TIMES

POS	DRIVER	QUALIFYING 1	QUALIFYING 2	QUALIFYING 3
1	VETTEL	1m25.381s (2)	1m26.420s (2)	1m26.479s
2	ROSBERG	1m25.556s (3)	1m26.626s (4)	1m27.102s
3	ALONSO	1m26.656s (9)	1m26.590s (3)	1m27.539s
4	WEBBER	1m26.689s (10)	1m26.963s (6)	1m27.572s
5	HAMILTON	1m25.342s (1)	1m26.698s (5)	1m27.677s
6	GROSJEAN	1m26.453s (8)	1m26.161s (1)	1m27.737s
7	RICCIARDO	1m27.209s (16)	1m27.078s (8)	1m28.052s
8	VERGNE	1m27.124s (15)	1m27.363s (9)	1m28.081s
9	MASSA	1m26.817s (13)	1m27.049s (7)	1m28.109s
10	HULKENBERG	1m26.071s (4)	1m27.441s (10)	1m29.582s
11	KOVALAINEN	1m26.266s (5)	1m27.456s	-
12	DI RESTA	1m26.275s (6)	1m27.798s	-
13	BOTTAS	1m26.790s (12)	1m27.954s	-
14	PEREZ	1m26.741s (11)	1m28.269s	-
15	BUTTON	1m26.398s (7)	1m28.308s	-
16	SUTIL	1m26.874s (14)	1m28.586s	-
17	MALDONADO	1m27.367s	-	-
18	GUTIERREZ	1m27.445s	-	-
19	PIC	1m27.843s	-	-
20	VAN DER GARDE	1m28.320s	-	-
21	BIANCHI	1m28.366s	-	-
22	CHILTON	1m28.950s	-	-

QUALIFYING STATISTICS

	HEAD TO HEAD	
VETTEL	17	2
ALONSO	11	8
BUTTON	9	10
RAIKK'N/KOVAL'N	11	8
ROSBERG	8	11
HULKENBERG	18	1
DI RESTA	12	7
MALDONADO	8	11
VERGNE	4	15
PIC	11	8
BIANCHI	17	2



BAD BOYS & ENGINE USAGE

	PENALTIES	FINES	ENGINES
VETTEL	0	€25,200	8
WEBBER	3	€35,000	8
ALONSO	0	€16,000	8
MASSA	3	€10,400	8
BUTTON	1	€1000	8
PEREZ	2	€600	8
RAIKKONEN	2	€2500	8
GROSJEAN	3	€0	8
ROSBERG	0	€1300	8
HAMILTON	1	€0	8
HULKENBERG	2	€3000	8
GUTIERREZ	4	€1800	8
DI RESTA	0	€5700	8
SUTIL	2	€1000	8
MALDONADO	0	€120,000	8
BOTTAS	0	€10,900	8
VERGNE	0	€10,000	8
RICCIARDO	1	€0	8
PIC	3	€0	8
VAN DER GARDE	3	€12,400	8
BIANCHI	2	€2800	8
CHILTON	2	€300	8

ETHERINGTON/LAT

THE RACE: 71 laps, 190.101 miles

POS	DRIVER	TEAM	LAPS	TOTAL TIME	FASTEST LAP	PIT STOP	TIME IN PITS	GRID
1	SEBASTIAN VETTEL	RED BULL-RENAULT	71	1h32m36.300s	1m15.624s	2	55.409s	1
2	MARK WEBBER	RED BULL-RENAULT	71	+10.452s	1m15.436s	2	51.730s	4
3	FERNANDO ALONSO	FERRARI	71	+18.913s	1m15.496s	2	45.487s	3
4	JENSON BUTTON	McLAREN-MERCEDES	71	+37.360s	1m16.450s	2	46.534s	14
5	NICO ROSBERG	MERCEDES	71	+39.048s	1m16.442s	2	46.081s	2
6	SERGIO PEREZ	McLAREN-MERCEDES	71	+44.051s	1m16.246s	2	44.988s	19
7	FELIPE MASSA	FERRARI	71	+49.110s	1m16.470s	2	62.364s	9
8	NICO HULKENBERG	SAUBER-FERRARI	71	+1m04.252s	1m16.802s	2	47.124s	10
9	LEWIS HAMILTON	MERCEDES	71	+1m12.903s	1m16.692s	2	64.463s	5
10	DANIEL RICCIARDO	TORO ROSSO-FERRARI	70	-1 lap	1m16.974s	2	46.061s	7
11	PAUL DI RESTA	FORCE INDIA-MERCEDES	70	-1 lap	1m16.855s	2	46.567s	12
12	ESTEBAN GUTIERREZ	SAUBER-FERRARI	70	-1 lap	1m16.528s	2	46.995s	17
13	ADRIAN SUTIL	FORCE INDIA-MERCEDES	70	-1 lap	1m16.049s	3	70.143s	15
14	HEIKKI KOVALAINEN	LOTUS-RENAULT	70	-1 lap	1m17.249s	2	45.665s	11
15	JEAN-ERIC VERGNE	TORO ROSSO-FERRARI	70	-1 lap	1m16.790s	3	71.089s	8
16	PASTOR MALDONADO	WILLIAMS-RENAULT	70	-1 lap	1m17.554s	2	50.334s	16
17	JULES BIANCHI	MARUSSIA-COSWORTH	69	-2 laps	1m17.717s	2	48.060s	21
18	GIEDO VAN DER GARDE	CATERHAM-RENAULT	69	-2 laps	1m17.590s	3	68.178s	20
19	MAX CHILTON	MARUSSIA-COSWORTH	69	-2 laps	1m17.281s	3	71.731s	22
R	CHARLES PIC	CATERHAM-RENAULT	58	suspension	1m18.434s	1	24.099s	18
R	VALTTERI BOTTAS	WILLIAMS-RENAULT	45	accident	1m16.840s	2	47.861s	13
R	ROMAIN GROSJEAN	LOTUS-RENAULT	2	engine	1m20.898s	-	-	6

Weather: Dry. Winner's average speed: 123.169mph. Fastest lap: Webber 1m15.436s (127.776mph) on lap 51. Lap leaders: 1-71 Vettel

TYRE CHOICE

STINT 1	STINT 2	STINT 3	STINT 4
Medium	Medium	Hard	
Medium	Medium	Hard	
Medium	Hard	Medium	
Hard	Medium	Medium	
Medium	Hard	Hard	
Medium	Medium	Hard	
Medium	Medium	Hard	
Medium	Hard	Hard	
Medium	Hard	Hard	
Medium	Hard	Hard	
Medium	Medium	Hard	
Hard	Medium	Medium	
Medium	Medium	Hard	Medium
Medium	Hard	Medium	Hard
Medium	Medium	Hard	Hard
Medium	Hard	Hard	
Medium	Hard	Medium	
Medium	Hard	Medium	
Medium	dnf		

Option tyre in bold; new set in red; used set in black

DRIVERS' STANDINGS

POS	DRIVER	PTS	AUS	MAL	PRC	BRN	E	MC	CDN	GB	D	H	B	I	SGP	ROK	J	IND	UAE	USA	BR
1	VETTEL	397	3 rd	1 st	4 th	1 st	4 th	2 nd	1 st	ret	1 st	3 rd	1 st	1 st	1 st	1 st	1 st	1 st	1 st	1 st	1 st
2	ALONSO	242	2 nd	ret	1 st	8 th	1 st	7 th	2 nd	3 rd	4 th	5 th	2 nd	2 nd	2 nd	6 th	4 th	11 th	5 th	5 th	3 rd
3	WEBBER	199	6 th	2 nd	ret	7 th	5 th	3 rd	4 th	2 nd	7 th	4 th	5 th	3 rd	15 th	ret	2 nd	ret	2 nd	3 rd	2 nd
4	HAMILTON	189	5 th	3 rd	3 rd	5 th	12 th	4 th	3 rd	4 th	5 th	1 st	3 rd	9 th	5 th	5 th	ret	6 th	7 th	4 th	9 th
5	RAIKKONEN	183	1 st	2 nd	2 nd	2 nd	10 th	9 th	5 th	2 nd	2 nd	ret	11 th	3 rd	2 nd	5 th	7 th	ret	-	-	-
6	ROSBERG	171	ret	4 th	ret	9 th	6 th	1 st	5 th	1 st	9 th	19 th	4 th	6 th	4 th	7 th	8 th	2 nd	3 rd	9 th	5 th
7	GROSJEAN	132	10 th	6 th	9 th	3 rd	ret	ret	13 th	19 th	3 rd	6 th	8 th	8 th	ret	3 rd	3 rd	3 rd	4 th	2 nd	ret
8	MASSA	112	4 th	5 th	6 th	15 th	3 rd	ret	8 th	6 th	ret	8 th	7 th	4 th	6 th	9 th	10 th	4 th	8 th	12 th	7 th
9	BUTTON	73	9 th	17 th	5 th	10 th	8 th	6 th	12 th	13 th	6 th	7 th	6 th	10 th	7 th	8 th	9 th	14 th	12 th	10 th	4 th
10	HULKENBERG	51	ns	8 th	10 th	12 th	15 th	11 th	ret	10 th	10 th	11 th	13 th	5 th	9 th	4 th	6 th	19 th	14 th	6 th	8 th
11	PEREZ	49	11 th	9 th	11 th	6 th	9 th	16 th	11 th	20 th	8 th	9 th	11 th	12 th	8 th	10 th	15 th	5 th	9 th	7 th	6 th
12	DI RESTA	48	8 th	ret	8 th	4 th	7 th	8 th	7 th	9 th	11 th	18 th	ret	ret	20 th	ret	11 th	8 th	6 th	15 th	11 th
13	SUTIL	29	7 th	ret	ret	13 th	13 th	5 th	10 th	7 th	13 th	ret	9 th	16 th	10 th	20 th	14 th	9 th	10 th	ret	13 th
14	RICCIARDO	20	ret	18 th	7 th	16 th	10 th	ret	15 th	8 th	ret	12 th	13 th	10 th	7 th	ret	19 th	13 th	10 th	16 th	11 th
15	VERGNE	13	12 th	10 th	11 th	ret	ret	8 th	6 th	ret	ret	12 th	12 th	ret	14 th	18 th	12 th	13 th	17 th	16 th	15 th
16	GUTIERREZ	6	13 th	12 th	ret	18 th	11 th	13 th	20 th	14 th	14 th	ret	14 th	13 th	12 th	11 th	7 th	15 th	13 th	13 th	12 th
17	BOTTAS	4	14 th	11 th	13 th	14 th	16 th	12 th	14 th	12 th	16 th	ret	15 th	15 th	13 th	12 th	17 th	16 th	15 th	8 th	ret
18	MALDONADO	1	ret	ret	14 th	11 th	14 th	ret	16 th	11 th	15 th	10 th	17 th	14 th	11 th	13 th	16 th	12 th	11 th	17 th	16 th
19	BIANCHI	0	15 th	13 th	15 th	19 th	18 th	ret	17 th	16 th	ret	16 th	18 th	19 th	18 th	16 th	ret	18 th	20 th	18 th	17 th
20	PIC	0	16 th	14 th	16 th	17 th	17 th	ret	18 th	15 th	17 th	15 th	ret	17 th	19 th	14 th	18 th	ret	19 th	20 th	ret
21	KOVALAINEN	0	-	-	-	-	-	-	-	-	-	-	-	-	-	-	-	-	-	14 th	14 th
22	VAN DER GARDE	0	18 th	15 th	18 th	21 st	ret	15 th	ret	18 th	18 th	14 th	16 th	18 th	16 th	15 th	ret	ret	18 th	19 th	18 th
23	CHILTON	0	17 th	16 th	17 th	20 th	ret	14 th	19 th	17 th	19 th	17 th	19 th	20 th	17 th	17 th	19 th	17 th	21 st	21 st	19 th

SECTOR 1 TIMES

POS	DRIVER	TIME
1	PEREZ	19.013s
2	SUTIL	19.096s
3	ALONSO	19.164s
4	VETTEL	19.187s
5	WEBBER	19.209s
6	VETTEL	19.235s
7	GUTIERREZ	19.246s
8	HAMILTON	19.280s
9	BUTTON	19.307s
10	HULKENBERG	19.319s

SECTOR 2 TIMES

POS	DRIVER	TIME
1	WEBBER	38.396s
2	VETTEL	38.603s
3	ALONSO	38.750s
4	SUTIL	38.957s
5	ROSBERG	39.043s
6	GUTIERREZ	39.072s
7	HAMILTON	39.092s
8	BUTTON	39.112s
9	MASSA	39.148s
10	PEREZ	39.333s

SECTOR 3 TIMES

POS	DRIVER	TIME
1	SUTIL	17.571s
2	ALONSO	17.582s
3	VETTEL	17.706s
4	PEREZ	17.722s
5	DI RESTA	17.745s
6	GUTIERREZ	17.789s
7	WEBBER	17.804s
8	HULKENBERG	17.820s
9	RICCIARDO	17.840s
10	HAMILTON	17.845s

SPEED TRAP (MPH)

POS	DRIVER	SPEED
1	PEREZ	194.2
2	DI RESTA	193.3
3	SUTIL	192.5
4	BUTTON	191.8
5	ALONSO	191.8
6	MASSA	191.0
7	VETTEL	190.8
8	MALDONADO	190.7
9	WEBBER	190.7
10	HAMILTON	190.3

SPEED TRAP BY EACH CONSTRUCTOR

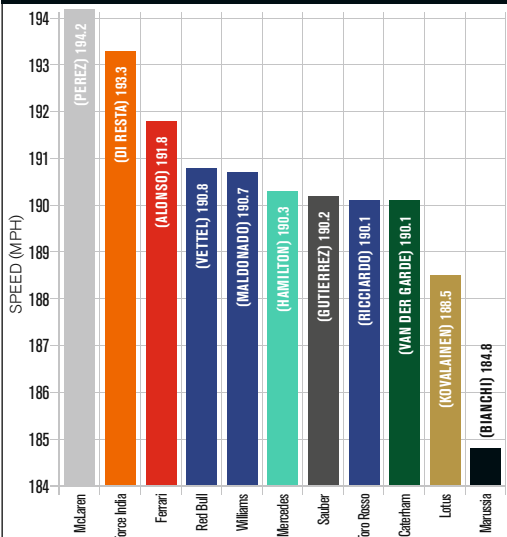

CONSTRUCTORS' STANDINGS

POS	DRIVER	PTS	AUS	MAL	PRC	BRN	E	MC	CDN	GB	D	H	B	I	SGP	ROK	J	IND	UAE	USA	BR
1	RED BULL	596	23	43	12	31	22	33	37	18	31	27	35	40	25	25	43	25	43	40	43
2	MERCEDES	360	10	27	15	12	8	37	25	37	12	25	27	10	22	16	4	26	21	14	12
3	FERRARI	354	30	10	33	4	40	6	22	23	12	14	24	30	26	10	13	12	14	10	21
4	LOTUS	315	26	14	20	33	18	1	2	10	33	26	4	4	15	33	25	21	12	18	0
5	McLAREN	122	2	2	10	9	6	8	0	0	12	8	8	1	10	5	2	10	2	7	20
6	FORCE INDIA	77	10	0	4	12	6	12	7</												

Webber's career should not be underestimated

While he struggled to match Sebastian Vettel week-in-week-out, Mark Webber has plenty to be proud of as he bows out of F1. By **EDD STRAW**

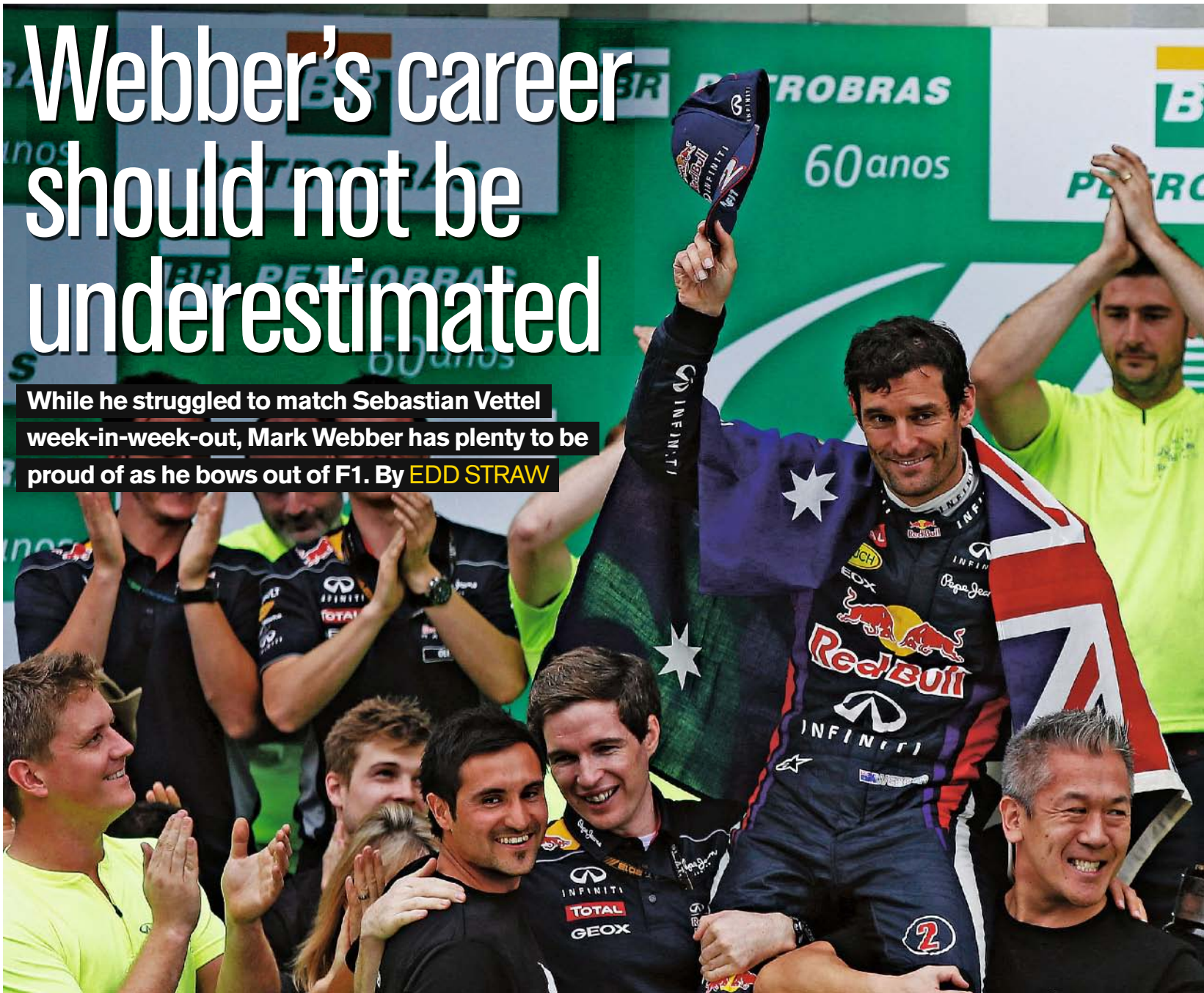

32

Mark Webber finished his grand prix career in the way he will be remembered, as second-best to Sebastian Vettel. But while his haul of nine grand prix victories and a trio of third-place finishes in the world championship pales in comparison with his team-mate's achievements, Webber's statistics do not do justice to how good he has been.

It would be stretching a point to say that he *should* have been world champion. But he *could* have been and came very close to doing so in 2010. His lack of adaptability hurt him in recent years, meaning he was only an occasional contender for race wins.

Considering it was a minor miracle Webber reached F1 at all, let alone stayed there beyond the

end of what was initially a three-race deal with Minardi in 2002, that he came so close is testament to his qualities. His long grand prix career was founded on ability and determination.

Red Bull team principal Christian Horner, who brought Webber to the team in 2007, believes the Australian is underestimated because of the strength of Vettel.

"People have undervalued how good Sebastian is, therefore to go up against him week-in-week-out is extremely difficult and it's only in the fullness of time that even Mark will recognise just how good Sebastian is and has been," said Horner. "That puts into perspective his own performance."

"Mark is a very fine racing driver. He had a reputation as a one-lap

WEBBER IN F1

13
POLES

12 SEASONS

215
STARTS

42 PODIUMS
19 FASTEST LAPS

1047.5
POINTS

10967 LAPS RACED

9 WINS



Ruffling feathers in 2003 Jaguar



Celebrating the end of a 215-race Formula 1 career

MARK HUGHES ON WEBBER



“He got into a great car just as a phenomenon arrived”

Mark Webber's inability to halt the Vettel steamroller should not be used as the gauge to assess his level.

It isn't speed he has lacked against Vettel, but rather his main tools have been taken away by control-spec, low-performance tyres and exhaust blowing, which has thrown into that set of demands a new trick that the old dog couldn't master.

Strip away exhaust blowing – 2010 and the first part of 2012 – and Webber's performance against Vettel becomes highly competitive. Strip away control tyres and revert to full-on, high-grip, tyre-war rubber and he'd be formidable. Even to this day, he invariably has a small advantage over Vettel through high-speed sections. It's just that Vettel invariably has a big advantage over him through intricate slow-speed, exhaust-blowing corners.

Were F1 still a tyre-war formula, better still one with active ride where being quick is all about how far you can push yourself through the fastest sections, there's no reason to believe Webber would not be Mansell-like in his suitability.

His early days in the Michelin-shod Jaguar bore witness to some remarkable qualifying performances. He had it on the front row at Sepang on merit – faster than all sorts of superstars in cars that were definitely faster. The Jag would invariably kill its tyres in the race, leaving him to tumble backwards and giving the impression that he couldn't race.

His misfortune was that after all the years of struggle in sub-par machinery, he finally got into a great car just as a phenomenon over 10 years his junior arrived in the same team.



Vettel skews perception of Webber



First win came in mid-2009

specialist in the early days of his career and it's only the level that Sebastian has been operating at consistently that has put a different perspective on things. It has just been unlucky for him that Sebastian came onto the scene during his career. Without Sebastian, he was potentially a world champion."

After marking his debut with Minardi in Australia in 2002 with a remarkable fifth place, Webber spent several years as a highly-rated driver who was never in the right place at the right time. Two years with Jaguar in 2003-2004 yielded some stunning qualifying performances, but few tangible results. The 2003 Hungarian Grand Prix, where he qualified third and ran second behind Fernando Alonso for the first part of the race before finishing sixth stands as one of his best drives. Webber has suggested his driving peaked

during his Jaguar days.

Two years with Williams and then two with Red Bull produced only patchy results until his breakthrough victory at the Nurburgring in 2009. It was a stunning performance after being hit with a drive-through penalty.

During his five seasons at the front with the Red Bull, there were also two victories at Monaco and two at Silverstone, for a driver who had waited too long for his success. He made his debut at 25 and did not get into a winning car until he was 32. And while it took him time to get to the front, he was determined to bow out while still competitive.

"There's not much that can please a driver more than having the car on the edge and having yourself on the edge in the ultimate machine," he said after the race on Sunday. "That is something which I will miss. But you want to make sure that you are

getting the best out of yourself."

At his best, Webber was devastatingly fast. He struggled to sustain that in a way that the true greats do, but on his day he was a match for anyone. As for his retirement, he could not have timed it better. There was sign of emotion after the race, particularly as he completed the slowdown lap,

helmet off. There were no regrets for a driver who deserves his place among those who were almost, but not quite, good enough to be world champion. And to his credit, unlike some nearly-men, he knew when to call it quits.

As he said before the race, "if the Kleenex is out, I have made the wrong decision".

Why F1 2014 will be different

Sebastian Vettel and Red Bull have dominated Formula 1 under its current regulations package. But, as **EDD STRAW** explains, next year everything changes, giving the rest a chance to catch up

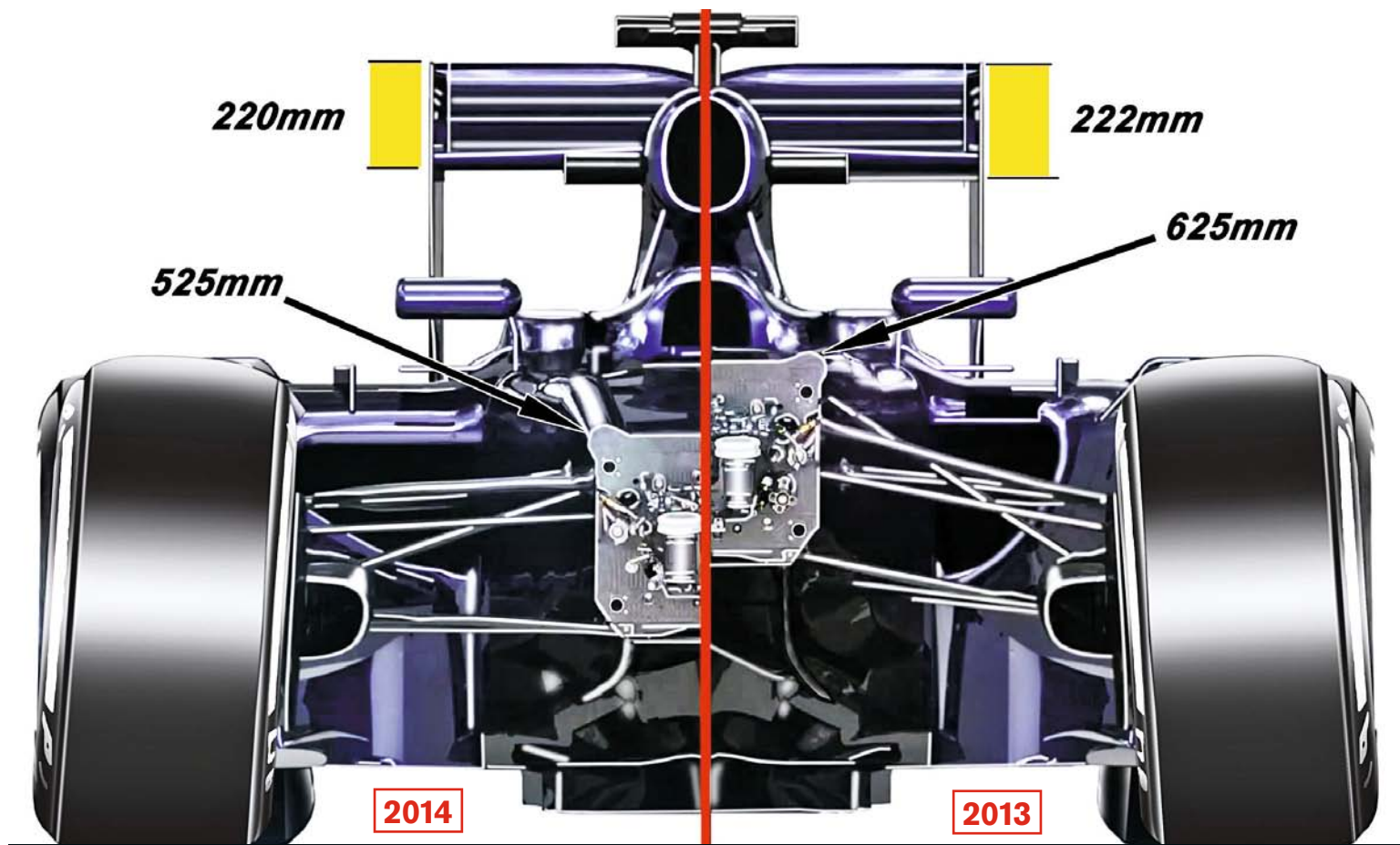

34

The foundations of Red Bull's clean sweep of both the drivers' and constructors' world championship were laid at the start of 2009. Adrian Newey's Red Bull-Renault RB5 did not win that year's title, primarily thanks to missing a trick with the double diffuser early on, but the fundamental aerodynamic concept

was stronger than that of its rivals. Newey describes the subsequent Red Bulls as direct descendants of that car. But while the team's technical excellence and incredible aerodynamic understanding remains, the major rule changes for 2014 built around the new 1.6-litre turbocharged engine are a whole new challenge.

This does not mean F1's dominant force will automatically be toppled next year. But the rule changes will ensure that the story of next season will be very different to 2013.

NEW ENGINES

The 2.4-litre V8 engines had their swansong at Interlagos on Sunday, meaning that when the grid reforms in Melbourne on March 16 next year, the look and sound of F1 will have changed dramatically.

The new 1.6-litre turbocharged engine is only part of the equation. The engine is now more correctly referred to as the 'power unit' as it features two types of energy recovery systems (ERS) – kinetic energy harvested under braking, a la the current KERS, and heat energy taken from turbo waste gases. This will give a power output of more than 760bhp provided the maximum electrical energy is deployed on top of the engine's own power.

Although work on these engines has been going on for several years, they will not run in anger until the

"Other than Mercedes, which will continue with Rosberg and Hamilton, every top team on the grid will field a revised line-up"

Jerez test gets underway on January 28. In total, teams will have only 12 days of running before the Australian GP to troubleshoot the new powerplants. Few expect reliability to be straightforward.

NEW TYPE OF RACING

As part of the drive to make F1 more environmentally friendly, a strict fuel limit has been put in place for 2014. Each car now has only 100kg of fuel to complete a full grand prix distance, a cut of around one-third from the current level. This will make fuel-saving paramount.

The complexity of the new engines means this is not a simple case of the driver taking it easy.

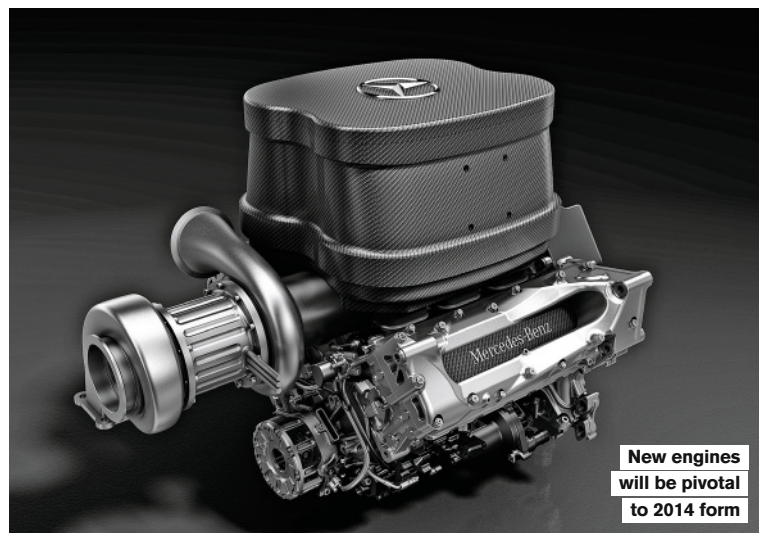

New engines will be pivotal to 2014 form

Ugly noses are likely thanks to 2014 regulations

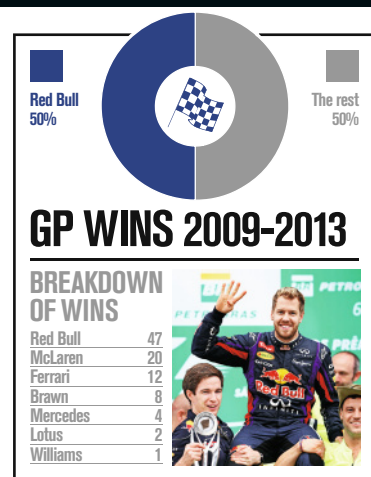
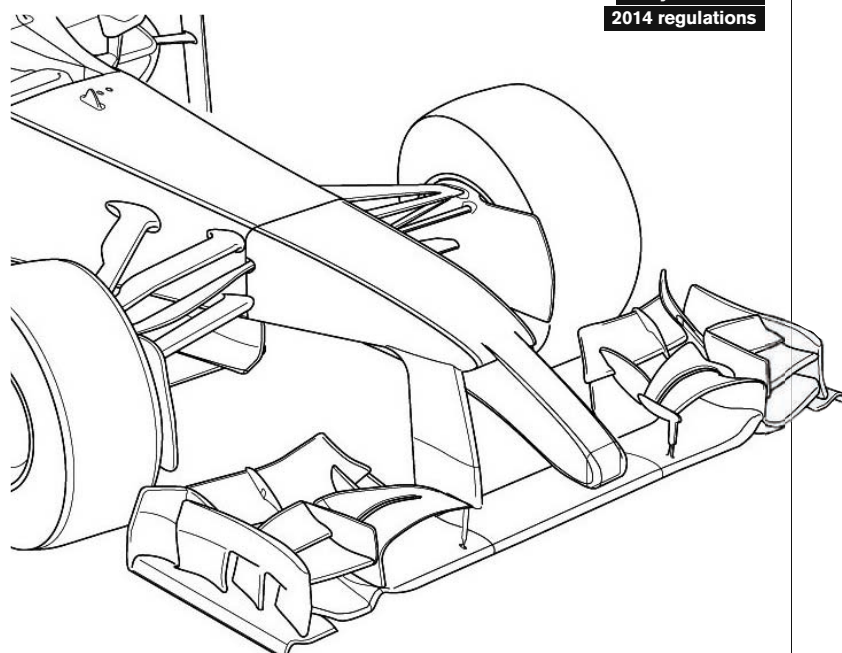
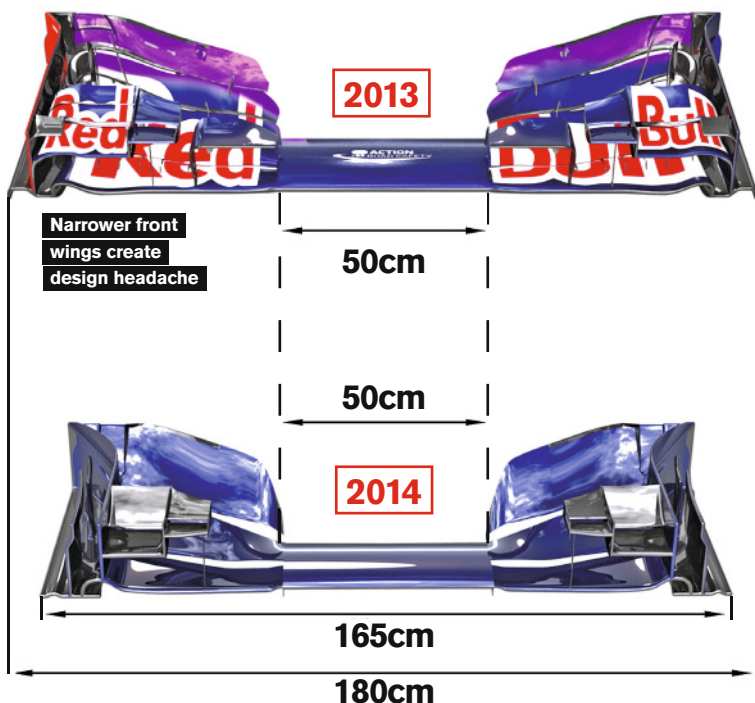

The electrical energy will be used in a far more intricate way than the current KERS. In a 2013 car, KERS offers an 80bhp boost for 6.7 seconds each lap. While next year's ERS could offer 163bhp for 33 seconds per lap (with the caveat that the maximum permitted energy-harvest rate means it takes two laps to store away that amount of energy), it will be used in a very different way.

There will be times in slower corners where cars are running exclusively using electrical power. Also, the ERS energy will be used piecemeal to even out the torque curve of the engines to make power delivery better.

NEW STYLE OF DRIVING

The new engines will behave very differently to the old ones. While the rev limit is 15,000rpm, down from 18,000 rpm currently, drivers will very rarely top out in any of the eight forward gears (ratios to be decided and fixed pre-season) available next year.

The vast torque of the engine also means controlling wheelspin

will be extremely difficult. Some drivers who have sampled the car in the simulator have stated that in fast corners they will be close to rolling through off-throttle. In slower corners, there will be times when drivers are in far higher gears than they currently use.

This means that there are predictions of far more drivers spinning off thanks to the power delivery to the rear wheels.

NEW AERO

AUTOSPORT recently revealed the shocking new-look noses for 2014 (top right), with a drooping front section caused by a combination of the designers' desire to keep the chassis as high as possible to maximise the airflow under the car, and the drive for safety with a lower nose. This is not the only change.

The front wings are now narrower. With the FIA-mandated neutral centre section of the front wing just as wide, this means that the highly-developed outboard section of the wings that are currently key to the aero of the whole car will be moved closer

to the centre section. With the current front wings, the aim is to turn the air around the outside of the front tyres. As the front wing is narrower, this will be much harder to achieve, giving the aerodynamicists a headache.

As AUTOSPORT's technical correspondent Gary Anderson explains, there are also consequences of the suspension geometry (main picture).

"There's a significant change in the front bulkhead height," he says. "But immediately behind the bulkhead you can ramp it up to 625mm. Current cars have the top wishbone leg as high as possible to get the bottom of the chassis up and that seriously compromises the suspension geometry – because aero takes precedence. But next year opens the way for more sensible geometries.

At the rear of the car, exhaust-blown downforce is now entirely outlawed because the exhaust must exit the car well behind the rear wheel centreline, while the beam wing at the rear of the car has also been removed.

NEW TEAM LINE-UPS

Other than Mercedes, which will continue with Nico Rosberg and Lewis Hamilton in 2014, every top team on the grid will field a revised line-up next year.

Vettel himself has a new team-mate to contend with in the very rapid Daniel Ricciardo, while Ferrari's challenge is bolstered by the return of its most recent world champion, Kimi Raikkonen from Lotus.

Rookie Kevin Magnussen is a wild card addition to McLaren's line-up alongside Jenson Button, but perhaps the most interesting challenge could come from Romain Grosjean. The Franco-Swiss driver was Vettel's closest competition in the final six races of this year and is set to remain at Lotus.

POINTS IN LAST SIX RACES OF 2013

POS	DRIVER	POINTS
1	Vettel	150
2	Grosjean	75
3	Webber	69
4	Rosberg/Alonso	55
6	Hamilton	36



GT racing set for boom

GT promoter Stephane Ratel reckons the reorganisation of his two major championships for 2014 will bring in top competition. **GARY WATKINS** explains the turnaround in fortunes for the discipline

Stephane Ratel stood up at the pre-event reception for last weekend's Baku World Challenge FIA GT Series finale in Azerbaijan and described the grid for the event as "the best GT sprint grid since the days of the FIA GT1 World Championship". He was bang on in his assessment, and he's promising more of the same for next year with the reorganisation of his two pan-European championships.

The renaming of FIA GT as the Blancpain Sprint Series and the creation of an umbrella championship covering its seven weekends and the five events of the sister Blancpain Endurance Series are all part of a plan to revitalise GT sprint racing. The other tenets

of the relaunch are a €100,000 prize fund at each sprint round, and a new class to enshrine the position of a generation of young professional drivers who are turning their backs on single-seaters at an increasingly early age.

"We will have the right package under the right banner for GT sprint racing to become a big success," said Ratel. "With prize money we are taking a step on the way to becoming a more professional series. It's a rare situation.

"I have been working on this for 20 years. Now we have the teams and the cars, and we are not going to go crazy by going all over the world. It should work."

Ratel, who was one of the founding partners of the BPR Organisation that relaunched GT racing in Europe for 1994, has been able to offer the prize money for a number of reasons. Foregoing FIA status has saved funds, while he will next year command a sanction fee from each of the seven tracks promoting his sprints and it appears, although he will not confirm it, that he will be investing less money than this season in TV after re forging his old links with Eurosport.



Baku boasted strong line-up



PRO ENTRIES – SPRINT GT RACING

Top-class numbers in Ratel's flagship series have dwindled since 2010, but last weekend's Baku race hinted at a revival

2010	FIA GT1 World Championship (GT1)	22.2
2011	FIA GT1 World Championship (GT1)	17.2
2012	FIA GT1 World Championship (GT3)	14
2013	FIA GT Series Pro Cup (GT3)	10.4
2013	Baku FIA GT Series finale (GT3)	20

NUMBER OF ENTRIES 5 10 15 20 25



RATEL: "I have been working on this for 20 years. Now we have the teams and the cars"

AUTOSPORT SAYS



Gary Watkins
Special contributor

Laurens Vanthoor may have a point. The idea of something approaching 20 cars competing for victory across 12 races, including an event of the status of the Spa 24 Hours, could well add up to the best GT series in the world. Or, as the Belgian says, the one every GT pro would want to win.

The Blancpain GT Series title is going to have an amazing status next year, at least if Stephane Ratel's predictions on the quantity and the quality of the grid come to pass. The big question, however, is how it will stack up against the World Endurance Championship's GTE Pro class, or more correctly the World Endurance Cup for GT Drivers – which actually covers the GTE Am division as well.

It's an interesting debate. While the

WEC has the twin cachet of world status and FIA sanction, cars competing across the two Blancpain series will be racing for overall honours every weekend. It's a real teaser.

What probably swings it in favour of the WEC as we sit here looking forward to 2014 is the presence of factory teams. Their participation gives any series a prestige that goes far beyond that offered by the word 'world' and the acronym 'FIA'. So long as Aston Martin, Ferrari and Porsche are battling it out in WEC, then it will remain the most important GT title.

However, Ratel didn't go through with his ban on the factories, after consultation with his teams, so the door is open. Should they step over the threshold things could change.

The hope is that more teams will double up with the same GT3 machinery and compete in both the Endurance Series, which this year had a regular entry approaching 60 cars, and the Sprint championship, which only just kept its head above the psychological 20-car mark in 2013.

The prize money is clearly going to be an attraction, especially for the under-25-year-olds competing in the new 'Silver Cup'. Should a pairing win the championship race overall at a Sprint round next year, they would take home €50,000 from the weekend. What's more, there will also be a prize fund for the umbrella championship covering both series. An end-of-season

fund of €100,000 will be split between the drivers' and teams' champions of what will be known as the Blancpain GT Series, while there will also be Pirelli tyres on offer to the value of €140,000.

Single-seater giant Fortec Motorsport, which took its first tentative steps in the world of GT racing this year, believes that the prize money will be crucial in the team being able to attract funded drivers for next season.

"We want to do both series next year," says Trevor Foster, who manages Fortec's Mercedes GT programme. "It is hard to justify a budget for only five endurance races, but now we can offer a good package and the chance for the

drivers to win money. I think it could make a big difference if there is a chance for them to win 20 grand a weekend or whatever."

The Blancpain GT Series umbrella championship will be an attraction. Some are already suggesting that it will be the most prestigious GT title in the world next season, and one of those is one of the newly-crowned FIA GT Series champions.

"It is pretty clear that this will be the biggest championship in the world for GT cars," says WRT Audi driver Laurens Vanthoor, who sealed the title with Stephane Ortelli on the streets of Baku in Azerbaijan last Sunday. "Winning it will be the biggest

thing a GT driver can achieve from next season."

Ratel added: "You need multiple classes to build the grid. That's why we will be keeping a Pro-Am class [alongside the overall contenders and the Silver Cup runners, who will also compete for overall points]. If I can have eight to 10 cars in each class, I will be happy."

Even if Ratel achieves the lower target that would mean 16 cars competing for overall victories. Which is not far short of his average for the second year of GT1 World in 2011.



P46 BAKU REPORT

Quick and competitive Track Day Insurance

The first online "quote and buy" system solely for the track day user, supplied by established track day and motorsport insurance provider - Ryan Motorsport Insurance

INSUREMYTRACKDAY.COM

- ✓ Damage to your car on a track day, regardless of fault.
- ✓ Any circuit in Europe, including Spa and Nürburgring Nordschleife.
- ✓ Inclusive cover for barrier damage at the Nordschleife.
- ✓ Vehicle recovery available for circuits in Great Britain.
- ✓ Organisers and Clubs - promotional rates and discounts
- ✓ Storage and transit for vehicles and trailers

Log on to www.insuremytrackday.com to obtain your online quote today.

AUTOCOURSE™ 2013-14

Now in its 63rd year, AUTOCOURSE continues to go from strength to strength, maintaining its position as the world's most respected and sought-after Grand Prix annual.

Editor Tony Dodgins is joined by some of the sport's very best writers, including Maurice Hamilton, Mark Hughes, Simon Arron, and Gordon Kirby.

In-depth coverage of yet another thrilling F1 season is covered in minute detail, with complete race-by-race statistics complementing the entertaining race reports.

Chief photographer Andrew Hone contributes his beautifully crafted images, and he is supported by some of F1's most talented photographers from around the world.

The most complete record of the F1 season, AUTOCOURSE also covers GP2, GP3, Formula 3, WEC Sports and GT racing, Touring cars, Indycar and NASCAR in the United States, Karting and more.

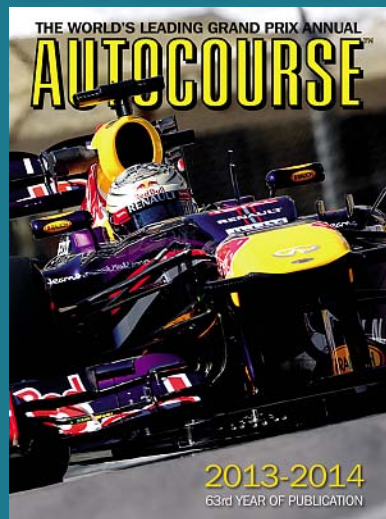

COVER ILLUSTRATION IS SUBJECT TO CHANGE

**ONLY
£43.50***

*RRP £49.95

*Offering free secure guaranteed delivery in time for Christmas

Last order date: 16th December

To order visit: www.autocourse.com
or call our hotline: +44 (0)1753 689693

AUTOCOURSE OFFICIAL HISTORY OF THE INDIANAPOLIS 500

2nd EDITION – FULLY REVISED AND UPDATED
by Donald Davidson and Rick Shaffer

The Indianapolis "500" is much more than merely the best-known motor race in the world. It is a cherished time-honoured institution with a glorious history dating back for over a hundred years. The first edition quickly sold out and is now highly collectable.

It is easily the most lavish and comprehensive history yet published, telling the incredible story of the "500" which draws hundreds of thousands of avid spectators on an annual basis.

Backed by more than forty pages of statistics, this is the ultimate book for fans of this U.S. open-wheel racing classic.

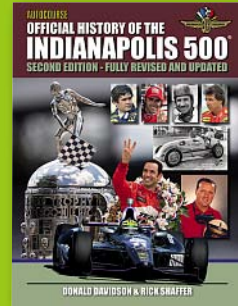

400 large format pages. • Over 500 Photographs
Limited quantities available

**ONLY
£43.50***

*RRP £49.95

*Includes FREE and secure guaranteed pre-Christmas delivery

Last order date: 16th December

GRAND PRIX WHO'S WHO & AUTOCOURSE
2013-14 FOR JUST £80 POST FREE
LIMITED TIME OFFER ENDS 9th December
Call, or visit website for full details



DMAX TWO ROUND WINTER CHAMPIONSHIPS



Daytona
Milton Keynes
15th Dec 2013

Daytona
Sandown Park
19th Jan 2014

Daytona Motorsport are delighted to announce that they will be running a two round Winter Championship, with races at Daytona Milton Keynes on 15th December 2013 and at Daytona Sandown Park on 19th January 2014.

Giving drivers a chance to experience the full DMAX Champs, these Winter rounds will comprise both endurance and heats events but with a shorter endurance race and a big discount on entry fees!

Enduro: £150 for one round or £140 each if you enter both rounds.

Heats: £135 for one round or £125 each if you enter both rounds.

For those drivers who wish to enter both Enduro and Heats Winter Championships, the prices are £245 for one round or £235 each round if you enter both rounds.

Tel: 0845 644 5504
www.daytonamax.co.uk



Fifteen questions for David Coulthard

Q Who would play you in a film of your life?

A Who's got a square head and a Scottish accent?

Who was your fiercest rival?
Michael [Schumacher].

Who was your childhood hero?
Alain Prost. It's always a pleasure to see him. I worked as a test driver for him at Williams, and then having him work as a test driver for Mika Hakkinen and me at McLaren in 1996 was a really cool thing.

When were you happiest?
The most complete I felt in a racing car was in the 1995 Williams FW17, with wide track, slick tyres, three-litre engines. I did most of my career on grooved tyres, which weren't great. I think I was at my happiest behind the wheel of a car in 1995, but I was at my strongest as a driver in 2000-2002. It was a very small window!

Which living person do you most admire and why?

This will seem like a cliché but you have got to admire your parents. Mine built a business, raised three kids, and took me racing all over the country when I was karting – just for me to put it in the barrier again. Today, I admire them because they are fully committed to living out their retirement going on as many holidays as they possibly can, until they decide they want to sit at home and stare out of the window in the family house they've always had. I admire anyone who is not selfish like racing drivers are and give their lives to helping others. I've never met a sportsman who is

not selfish, no matter how good a person they might be.

What has been your most embarrassing moment?

In racing it's hitting the pitwall in Adelaide in '95, of course, although there were mitigating circumstances. The downshift blip gave more rpm so on idle the car pushed on. I didn't just lock up and crash. I flicked down the gears, got more rpm than I should have, and the combination of that and being too close to the limit made me panic and I didn't pull the clutch in. That was embarrassing and very costly – it cost me more than £2 million in bonuses from Williams and in my new contract with McLaren! My bonus if I won at Williams was half a million pounds, and if I had won two races in '95 the contract I'd signed with McLaren would have put an extra million dollars on my annual retainer. I was never motivated by money, but that was expensive.

What is your most treasured possession?

I don't have one. I'm not one for stuff like that. I have all my cars up in Scotland, but if it all burned down... I don't look back, I'm all about the future.

Who would play you in a film of your life?

I don't know, who's got a square head and a Scottish accent?

What is your favourite smell?
I like Vanilla.

What is your guiltiest pleasure?

Nothing you can print! I do feel guilty about continuing to enjoy my life travelling to races at the expense of not being able to spend more time with my family.

To whom would you like to say sorry and why?

Not anyone that I haven't already apologised to.

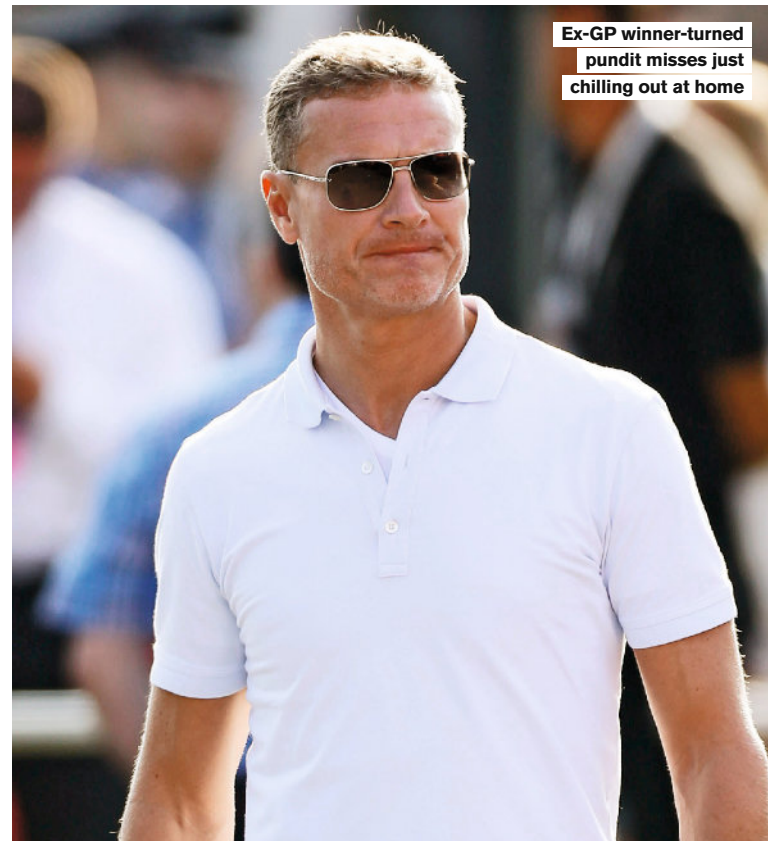

Ex-GP winner-turned pundit misses just chilling out at home

COATES/LAT

What does success feel like?

Success for me is having people to share it with. Whether it's your partner and you see your children growing up, or it's achieving as a sportsman. It's like being at the pyramids on your own, it doesn't mean as much if there's no one to share it with.

What has been your biggest disappointment?

I find the fact that humans seem to be hell-bent on killing each other and destroying the world so disappointing. What's wrong with just having a good time?

If you could edit your past, what would you change?

I'd have to dream something up. It's not something I reflect on particularly when I'm sat in Monaco

looking across the Mediterranean, wondering where it all went wrong!

How do you relax?

I hang out with family and friends. I take my son to school, go on a bike ride with my buddies, have lunch with the missus, go to the office in the afternoon, and always be back at home for bath time for the little guy and put him to bed. Then have dinner and go to bed. Just doing normal things makes me feel good.

When was the last time you cried?

I cry a lot on planes. I get very emotional if I'm flying away from the family. I could choose to spend more time around Monaco and develop my businesses there, but it just doesn't motivate me as much as what I do now. ✖



LAT

Driving the BTCC title winner

Andrew Jordan had only been BTCC champion for four days when **BEN ANDERSON** got the chance to test out Eurotech's Honda Civic, and it was a special experience

40



ALL PICS: EBREY/LAT



Anderson readies for his outing in a BTCC title winner

Many motorsporting adventures begin as father-and-son bonding exercises, but rarely do they lead to a British Touring Car Championship title. That Andrew Jordan and his father Mike have achieved just that is a fairytale result for the Midlands and their family-run Eurotech team.

That squad can trace its origins to ex-Formula Ford racer Mike's impulsive purchase of a 1972 Porsche 911E, which he used to win the 1987 Porsche Cup. Little could he have known that, a quarter of a century later, it would ultimately lead to his son claiming one of the biggest prizes in British motorsport.

"I raced Formula Ford for a season, but gave up because I blew an engine and couldn't afford to carry on," recalls Jordan Sr. "I had mates who let me have a go in their classic saloons, but I'd retired really, and had a family on the way."

"Then my dad left me £8500 when he died and I used it to buy a 911E and win the 1987 Pirelli Porsche Cup. We'd just had our daughter Sarah, we had no money and we were living in a small maisonette. I sat down with my wife and we said 'what shall we do with the money?'"

"I'd seen the car for sale and I said, 'I'd quite like to buy that'. She said 'do it'."

"I didn't have the money to run it, but I was working on spanners in a TVR garage and a guy from the mobile phone and telecoms trade came in for a service and saw the Porsche. He said: 'what are you going to do with it?' I said: 'Race it! But I haven't got the money'."

"You'll need sponsorship then," he said. He asked me how much a season would cost and when I told him he said: 'I'll put that up. But promise you'll win it because we'll make a big deal of it in my industry'."

"Without those two things – having the balls to buy a car I had no money to run, and meeting this mobile phone guy from Birmingham, none of this would have happened."

"Winning the BTCC is the culmination of all of that and it's very satisfying. I was British GT champion in 2001, so now we have two 'best of British' trophies!"

Only a few days after Andrew Jordan's historic moment at Brands Hatch, Eurotech is back to business with its Team Dynamics-built Honda Civic – rocking up to Donington Park for one final test before packing away for the winter.

"I drove the truck in myself this morning and suddenly it dawned on me that we're doing this for the first time as BTCC champions," says Mike. "That was a nice feeling!"

But this post-season test is unusual for two reasons: Not only is Eurotech operating for the first time as outright BTCC title holder, the Jordans are also going to allow AUTOSPORT to drive their championship-winning pride and joy, to find out what it's like to live in the office of a BTCC title winner.

"The plan is for Andy to go out first to warm everything up," says engineer Adam Hardy, who worked with Andy during his year with the works Triple Eight Vauxhall team in 2009, then spent some time in Aussie V8s before reuniting with the Jordans at the start of last season.

"Then we'll put you out for three or four laps to acclimatise, then 10 laps to build a rhythm. We'll debrief and look at data after that, then let you back out for a couple more runs." ▶



Anderson starts pressing on in NGTC Civic...

Early success for Mike Jordan came in Porsches



...after getting some advice from champ Jordan

► As I'm suiting up in preparation, Jordan Sr (no stranger to success behind the wheel of a touring car himself) offers some words of advice about the challenge to come: "The cars are 1280kg so they feel heavy, like a front-wheel-drive GT car," he explains. "It puts a lot of strain on the brakes – we go through three sets of discs a meeting and would put new ones on for every session at a BTCC round if we had more budget!"

"There are two types of pad: the 'sprint' pads are very good, but the enduro pads take a different style with more brake pressure to come alive. Andy produces monstrous initial pressure on the pedal, then bleeds off.

"You can left-foot-brake because the gearshifts are clutchless up and down, but watch out if you lock the diff because the engine will stall. It shouldn't be a problem today, but if it's really

wet Andy will use the clutch and right-foot-brake to avoid the risk.

"There's no pressure from us, just enjoy today."

"It's impossible not too," I say, as I step – suited and booted – out of the team truck and head for my date with the Pirtek-liveried Honda (probably the best-looking car on the grid).

When I slide into Andy's seat and get myself strapped in, the first thing that strikes me is how little visibility the driver has. Perhaps this is the natural concern of a single-seater driver, but I feel as though I can't sit high enough in the car to get my bearings (though naturally the engineer wants the driver to sit as low as possible to aid the weight distribution in the car). Plus, the mirrors look next to useless.

"I can see why touring car drivers keep driving into each other all the time," I remark to Hardy.

"They can't see a thing!"

A seat insert helps move me forward and up, and I'm feeling a bit better about my environment as the Neil Brown Engineering-tuned two-litre turbocharged Honda engine is fired up, and the Civic rolled backwards out of the garage onto the Donington pitlane. I fail to give it enough revs on my first attempt to venture out onto the track, so the engine has to be re-fired before the Honda and I can get to know each other a little better. I find visibility is much better once you're out on the track and your mind begins to focus on the job in hand.

My first run is in the damp on treaded Dunlop tyres, the front two taking a pounding from all the power going through the front wheels. It's a tentative exercise, because much of the circuit is still very slippery. In these conditions, the car

DATA CRUNCH: JORDAN v ANDERSON

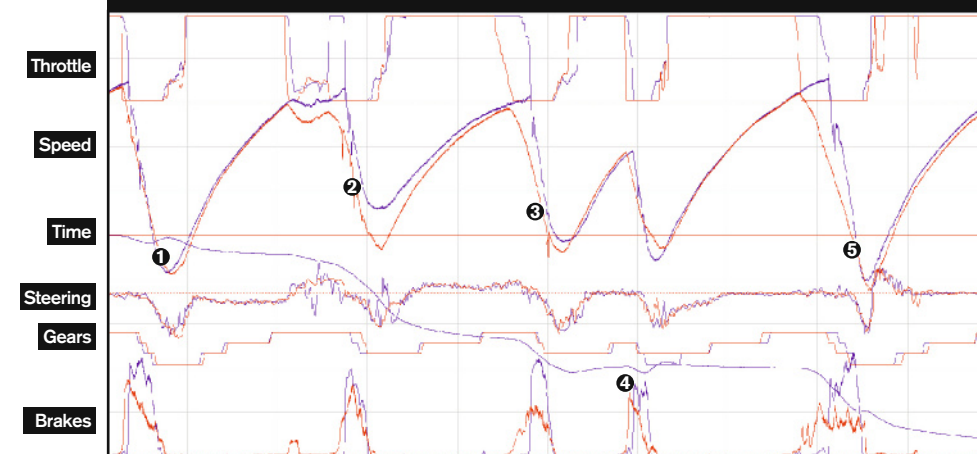

Ben:
1m14.695

Andrew:
1m11.925

① Andrew is fractionally later on the brakes into Redgate, but I make all that time back mid-corner as I bleed off the pedal. Andy's got the car better lined up for the exit, though, so gains time on the way out.

② I lose a second to Andy through the Craner Curves/Old Hairpin and up the hill that follows. I'm too gentle with the steering and let the car run too far to the right exiting the Craners, putting me off line for Old Hairpin.

③ Andy is more committed at McLeans, staying flat through Schwantz Curve and braking much harder and for less time entering the right-hander. My lazy entry means I gain on the exit by being earlier on the throttle.

④ Coppice is the only part of the lap where I gain time. Andy is fractionally later on the brakes, but I bleed off better and gain mid-corner. Our exits are almost identical, but I use fourth gear instead of third, which maybe helps.

⑤ Heavy traffic approaching the final chicane means I cannot brake properly for this right/left final section of the lap. I lose the best part of a second from here to the finish line trapped behind a Porsche Boxster.

feels like it has the right amount of power versus grip, and driving through the front wheels always helps with confidence on the throttle; the difficulty is knowing how hard to attack the turns – especially down through the Craner Curves and Old Hairpin where the track is at its wettest. I am momentarily caught out here when the back breaks away and the Civic slides into a big oversteer moment through the fastest corner on the circuit. Remembering the 'if in doubt, flat-out' mantra of front-wheel driving, I manage to gather it back up with only a brief trip over the grass on the exit. Phew!

I haven't got away with it though, because it happens in grandstand view of Mike as he's putting some laps on Philip Walker's Ford GT40!

"I saw that," Mike says wryly when I come clean in the garage later. Andrew politely asks me to come into the pits if I have any more excursions, just in case any grass has lodged in the radiator.

Whatever you say boss!

The car feels extremely surefooted almost all of the time, but when the grip disappears, it does so suddenly and with very little warning. My moment reveals to me how thin the knife-edge between 'total grip' and 'nothing' is with this car.

The clutchless gearshift (on which the team has done much work) is one of the most impressive features. It's lever-operation is silky-smooth in both directions and never misses a beat. The engine pulls pretty well for a road-based two-litre turbo too, and propels the car deceptively fast along Donington's straights. The beefy brakes feel excellent as well, though I know I'm not nearly getting the best from them.

The power steering is another matter entirely. This TOCA-mandated system is something BTCC drivers have complained about regularly and I can see why. The pump has to be turned to its maximum setting all the time (which surely can't help reliability) yet the car is very difficult to manipulate once it takes a set (rather like an ▶



About to tackle the challenge of the Craner Curves

Donington Park National circuit

PIRTEK'S PART IN EUROTECH TITLE

One of the key elements to Andrew Jordan's BTCC title has been the support of Pirtek. Not only have the company's colours made the Eurotech machines among the most striking on the grid, it has also provided the financial backing that has helped make the Honda Civic programme possible.

Mike Jordan first had dealings with Pirtek in 2004, when his John Guest contacts helped get a sticker on his British GT Porsche. Pirtek then remained a sponsor to JG as Eurotech went touring car racing.

The key moment came before the 2009 BTCC season. On the very day that Mike signed a deal for Andrew to join Triple Eight, John Guest withdrew its support as title sponsor as the economic crisis hit.

"I spent the next three weeks going to all our sponsors and managed to get Pirtek to step up to primary sponsor," says Jordan Sr. "Others, like long-term supporter CBT increased their help, and Hillwood Autos gave us a workshop to use."

A bit of family borrowing combined with the extra support filled the gap.

But Jordan's 2009 season at Triple Eight was not great and Mike and Andrew had to pull out something special again in the October presentation to the Pirtek directors and 90 franchisees. "I knew it was going to be a little bit difficult because we hadn't had a great year," he recalls. "I thought the only way we're going to get this back was to offer them a complete Pirtek car for 2010. A lot of them had always talked about Marcus Ambrose's Stone Brothers car in Australia.

"I was very aware some of the company felt the motor racing had run its course, the economy was in a dreadful state and they should not continue. I stood up, knowing if we didn't do this our team and Andrew's career were finished. I said: 'I think you are fundamentally wrong not to continue and this is why'. The last picture on my powerpoint presentation was the 2009 Vectra done like the Stone Brothers car for 2010. They all stood up and clapped!"

A vote from all the franchisees would be the decider and the Jordans gained enough support to sign off the project. It had worked, Eurotech brought a Vauxhall Vectra and the Pirtek board, headed by chairman Kelvin Roberts, pledged its full support.

Pirtek committed to a two-year deal prior to 2012, allowing Eurotech to buy the new NGTC Honda Civic, and the programme has subsequently been extended until the end of 2015.

"It made us comfortable and gave us stability," adds Mike. "They've turned into a fantastic sponsor.

"It makes me smile when I hear that Andrew got here on family backing. Without the commercial partners we've had since I won in Porsches, neither of us would have achieved the success we have."

Kevin Turner



Full Pirtek livery first appeared in 2010



Andrew and Mike have become a formidable combo

▶ old 1950s Aston Martin DB2 I drove here a few years ago) and the steering still feels heavier and more cumbersome than an elephant on tranquillizers.

“The power steering isn’t great,” concedes Jordan Sr. “It’s not too bad on a fast, flowing circuit like this, but at tight and twisty tracks like Oulton Park it feels like the steering wheel is locked. There’s no finesse. Andy has just worked really hard on his upper body strength.”

I feel I’m just starting to load up the steering properly at Redgate and McLeans as my first run comes to an end. I’ve managed to dip into the 1m19s, and easily overtake Team HARD’s VW Passat while I’m at it. Though I probably should be doing so given I’m in this year’s championship-winning car!

Adam kindly begins asking me about the balance and whether the car is pushing into understeer, but I resist the urge to act like I know what I’m talking about and instead tell him I’m still driving beneath the car at the moment, so



there's little point making comments on set-up.

Adam's review of the data confirms my suspicions that my corner-entries need work. I'm not leaning late or hard enough on the brakes and thus making the most of their potential to help turn the car more quickly. Instead, I am braking too early and for too long, making my turns a bit lazy and slow. My corners are "going on too long" as driver coach Rob Wilson would say. Though I'm told my use of the throttle pedal is "good", so that's something...

The driving style required sounds simple enough: heavy loading of the steering on the brakes as you pile straight for the apex, rotating the rear of the car as you bleed off the brake pedal to help it turn quicker and set the wheels straighter for a faster exit as you pick up the power again. 'Fast in, fast out'. But it requires a high level of trust and confidence in the car to make it work – something Andy clearly has in spades as he later hops back into the car for an exploratory run on slick tyres.

The track is drying out and it's time for the real fun to begin!

Unfortunately, my planned 10-lap run on dry tyres becomes two truncated five-lap spurts interrupted by red flags. Mike advises me to do everything "15 metres early" in order to progressively load the car and not upset the rear too much, and I am warned each time by the team to take care in building the rear tyre temperatures up before pushing too hard (the bigger NGTC Dunlops take much longer to warm up than the old S2000-spec tyres).

The traffic and stoppages make this difficult to achieve and give me no chance to build the necessary rhythm. I take a couple of big slides at Coppice (on the first run) and Redgate (on the second) as signs I have not achieved the necessary equilibrium to attack. My best lap of 1m14.7s is a full 2.7s slower than Andy managed before I hopped back in to trundle around (though I did lose a second stuck behind a pesky Porsche Boxster at the chicane).

The car feels very heavy in the dry (I later learn we are running the maximum 45kg of success ballast, as is the norm when Eurotech tests these days) and you have to be extremely careful not to upset the car too much through the faster sweeps. It tends to take a set course, which you have to run with or be "really busy on the wheel getting it to come back", as Andy puts it.

Back in the garage I remark to Mike how disjointed the different phases of cornering feel as you load and unload the steering. He tells me how Andy has managed to smooth them out by working hard on his technique: braking correctly and then further refining his steering inputs. "What he does with his steering mid-corner has given him the edge over the other Honda drivers this year," says Mike. "Getting within a second in one of these cars wouldn't take too long, but finding those last few tenths is really tricky."

Success on that journey of discovery is why Mike's son is now British Touring Car champion. And it couldn't have happened to a nicer family. 🏆

Honda Civic five-door

SUSPENSION: Double-wishbone with Penske dampers; King & Eibach springs

WHEELS: 18in Dynamics Pro Race 1.2

TYRES: Dunlop

ENGINE: Neil Brown Engineering Civic Type R, 16-valve, inline four-cylinder, turbocharged, twin-overhead camshaft, fuel-injection

CAPACITY: 2000cc

POWER: 300+bhp

TOP SPEED: 160mph

GEARBOX: Xtrac 1046 six-speed sequential

CLUTCH: AP Racing Carbon

BRAKES: AP Racing

WEIGHT: 1280kg (with driver)

CUSTOMER (CIVIC) FOCUS

After Mike Jordan did a deal to buy customer NGTC Honda Civics from Team Dynamics for the 2012 BTCC season, rival team boss David Bartrum (who decided to build his own Motorbase Ford Focuses instead) described him as "the smartest man in the paddock".

That move has indeed proved shrewd, as Eurotech has developed its car to the point where Jordan Jr has regularly outpaced his more illustrious factory rivals in taking this year's crown.

Engineer Adam Hardy says the team has left no stone unturned in its pursuit of better performance, and has increasingly ploughed its own furrow with the Honda as time has gone by.

"When we first started with the car we were quite happy to take a back seat and let Dynamics find the problems, which early on were mainly to do with the damping and spring package," he explains.

"That got sorted for Thruxton and then we started to do our own testing. Originally we had one of their engineers helping Jeff [Smith, Jordan's team-mate], but he switched engineers before the Croft round so we lost that Dynamics presence.

"Our first big breakthrough came at the summer TOCA test at Snetterton. We did a big sweep of changes to cambers, rideheights, rollbars, springs. We found a lot of time and went on to take out first win there [after Jason Plato and Matt Neal collided in race two]."

Hardy says Eurotech has also worked hard to overcome the Honda's Achilles' heel: a difficulty in maintaining rear-tyre temperature. "The art of setting up front-wheel-drive cars is gaining front-end grip without losing stability at the rear," adds Hardy. "We've found a big thing playing with rollcentres and we started going testing everywhere with full ballast, because that's the worst-case scenario for the tyres.

"We came away from the summer test this year with a really good understanding of the soft tyre – I don't think there is anyone who can come close to us on that."

In order to compete with the might of teams like Dynamics, Triple Eight and WSR, Eurotech is also meticulous with its car preparation between events.

"We completely strip the car after every meeting –

our clutch, differential and gearbox, and we always have the engine out," says Hardy. "The top teams are all doing that and it's a high level of intensity.

"The dampers are dynoed every second round and we have a strict service schedule for the car. A huge chunk of the budget is spent on brakes – we go through three sets of discs a weekend – but there's a massive performance gain there so we can't neglect them."

The NGTC regs were designed to make the BTCC more accessible to smaller teams, but Hardy says there is still enough room for adjustment with the standard parts to allow the bigger (or cleverer) outfits to engineer an advantage.

"There are so many things you can do to make a difference that the good teams still end up at the front and the bad ones at the back," he argues. "We all have to run Penske dampers and Xtrac diffs, but once you've got the parts there's a lot of freedom to make a difference to the car.

"People say there's no more you can get out of these cars but we can't afford to stand still and I still think there's time to find."



Hardy reckons there's more to come from the Civic

FIA GT
Baku
 November
 23-24
 Round 6/6

RESULTS

MAIN RACE: 30 LAPS, 81.65 MILES

1	STEPHANE ORTELLI (MC)/LAURENS VANTHOOR (B)	1h00m39.010s
2	SEBASTIEN LOEB (F)/ALVARO PARENTE (P)	+5.755s
3	ROB BELL (GB)/KEVIN ESTRE (F)	+11.313s
4	MAXIMILIAN BUHK (D)/ALON DAY (IL)	+15.312s
5	DOMINIK BAUMANN (A)/HARI PROCZYK (A)	+31.029s
6	FILIP SLADECKA (SK)/STEFAN ROSINA (SK)	+39.168s
7	CESAR CAMPANICO (P)/MICHAEL AMMERMULLER (D)	+39.464s
8	ALEXANDER SIMS (GB)/STEF DUSSELDORP (NL)	+39.884s
9	ANDY SOUCEK (E)/OLIVER TURVEY (GB)	+41.553s
10	ANTHONY BELTOISE (F)/HENRY HASSID (F)	+46.205s

Winners' average speed: 80.77mph. Fastest lap: Rene Rast (Audi R8 LMS ultra), 1m42.583s, 95.51mph.

QUALIFYING RACE: 32 LAPS, 87.09 MILES

1	RENE RAST (D)/NIKI MAYR-MELNHOF (A)	1h14m26.088s
2	ORTELLI/VANTHOOR	+1.226s
3	BELL/ESTRE	+2.190s
4	SIMS/DUSSELDORP	+2.787s
5	NICKY CATSBURG (NL)/MAXIME MARTIN (B)	+5.710s
6	SERGEY AFANASIEV (RUS)/ANDREAS SIMONSEN (S)	+7.761s
7	FRANK STIPPLER (D)/EDWARD SANDSTROM (S)	+7.986s
8	ALLAM KHODAIR (BR)/CACAO BUENO (BR)	+8.606s
9	MARKUS WINKELHOECK (D)/ENZO IDE (B)	+9.317s
10	NICK TANDY (GB)/MARCO HOLZER (D)	+10.498s

Winners' average speed: 70.20mph. Fastest lap: Mayr-Melnhof, 1m44.296s, 93.94mph.

CHAMPIONSHIP

1	VANTHOOR/ORTELLI	132	6	RAST	80
2	SANDSTROM/STIPPLER	110	7	BUHK	70
3	MAYR-MELNHOF	92	8	PARISY/ZUBER	61
4	LOEB/PARENTE	82	9	ROSINA	51
5	DAY	80	10	BUENO/KHODAIR	40

PRO-AM

1	AFANASIEV/SIMONSEN	136	4	CAMPANICO	97
2	PROCZYK	133	5	REIP	76
3	BAUMANN	113	6	STUMPF	73

POINTS SYSTEM EXPLAINED

25-18-15-12-10-8-6-4-2-1 for top 10 finishers in main race. 8-6-4-3-2-1 for top 6 finishers in qualifying race.



Estre starred in Hexis McLaren

FOR IN-DEPTH RESULTS
 forix.autosport.com



The #11 Ortelli/Vanthoor Audi edges ahead

ALL PICS: VIMAGES/FABRE

Audi drivers crowned in chaotic Baku finale

IT WAS SOMEHOW FITTING THAT STEPHANE ORTELLI and Laurens Vanthoor should come through the mayhem on the streets of Baku to claim victory in the main FIA GT Series race to take the title. The WRT Audi drivers might not have been the fastest pairing through this year's series, but they were probably the most consistent of the frontrunners — and they didn't put a foot wrong over the course of two dramatic and combative races on the streets of the Azerbaijani capital last Sunday.

Equally fitting was that they took the crown — a fifth major GT title success for Ortelli over his long career — with a Championship Race victory aboard their Audi R8 LMS ultra, something missing from their season up to the final event. They didn't need to win, but there was the little matter of the not-insignificant prize fund on offer in Baku.

Vanthoor was on course for second and the title after the mandatory pitstops in the second race and was told to play it safe. Even so, he was making inroads into race leader Alon Day in the best of the Gravity Charouz Mercedes-Benz SLS AMGs, and with the difference between first and second being a cool €50,000, he was suddenly told to speed up.

"The team told me bring the car home and then they told me to push," said Vanthoor. "Then I asked, 'what position am I in? And they said 'P1.'" Vanthoor passed the Merc, which Day shared with Maxi Buhk, after an engine alarm came on and briefly cut the power to one cylinder. But, by rights, Vanthoor should have been in the lead anyway.

Ortelli had led away from the front row only to get baulked behind one of the BMW Team Brazil Z4s just as it was encountering a problem. It shouldn't have mattered because the two cars that went past him, the Boutsen McLaren MP4-12C of Frederic Vervisch and Markus Winkelhock's Phoenix Audi, had straight-lined the first chicane at the start and were given drive-through penalties.

The problem for Ortelli came when he followed Vervisch into the pits to hand over to Vanthoor. The McLaren had lost power courtesy of a broken alternator cable, and slowed the Audi to such an extent that Ortelli nudged the MP4-12C down the pitlane to get to his own box.

The second WRT Audi of Edward Sandstrom

and Frank Stippler, who could still win the championship if they beat their team-mates, was similarly delayed. The duo then saw their hopes disappear when an airline exploded, forcing the team to use a trolley jack during the pitstop.

The solo Hexis McLaren MP4-12C was also delayed by Vervisch's slow entrance into the pitlane, but the combined effects of the safety car and some amazing laps from Porsche Supercup driver Kevin Estre somehow made up for the puncture that forced team-mate Rob Bell into the pits at the end of the first lap.

Estre, who was racing a sportscar other than a Porsche for only the third time, made quick progress from eighth to fourth after the pitstops, and then made it past Day and Alvaro Parente (in the McLaren he shared with Sebastien Loeb) in one go when all three cars made contact.

The stewards subsequently penalised Estre and Day, demoting them to third and fourth behind the Loeb McLaren. Day was done for "avoidable contact", which was harsh, but Estre remarkably got his penalty for exceeding track limits. Apparently there was a white line on the inside of the hairpin across which he might have had 10 per cent of his car. It was a ridiculous take on a racing incident.

Estre's was the performance of the inaugural meeting on the new Baku World Challenge Circuit, though Rene Rast's pole lap and drive on the way to victory with Niki Mayr-Melnhof in the Qualifying Race ran it close. Ortelli, the old pro that he is, and that old-head-on-young-shoulders, Vanthoor, did what was expected — and a little more besides.



Ortelli and Vanthoor celebrate with WRT boss Vincent Vosse

DECOSTER

IN THE PADDOCK

Gary Watkins



Improved Baku event was a qualified success

IT WOULD BE EASY TO WRITE OFF THE inaugural event on the Baku World Challenge Circuit as a disaster. The repeated delays were clearly unacceptable, but the races did happen, the action was good and the circuit was well received. The second-ever motor race in Azerbaijan ticked a lot of boxes.

Magicking street circuits out of public roads closed the night before the action starts is never going to be a simple task, especially first time out. But the problem for the organisers last weekend was that their event drew unfavourable comparison with last year's Baku City Challenge on a different layout right in the centre of the city. The 2012 races went off without a hitch and with only short delays.

What we shouldn't forget is that they came up with a much more ambitious circuit design for 2013. The short circuit of last year was all point-and-squirt and offered the drivers little in the way of a challenge.

If Baku is to become scene of the kind of 'World Finals' that series organiser Stephane Ratel has suggested, then it needs to take place on a damn good circuit.

And we might have seen that last weekend.

BIG NUMBER

8 The number of championship titles the WRT Audi team has won in its four years of existence. It took the Belgian Belcar drivers' and teams' crowns in 2010, claimed both titles in the Blancpain Endurance Series in 2011 and 2012, and has now completed the double in FIA GT, thanks to its success in the Baku finale.

Event delayed by chicane mods

THE ISSUES THAT RESULTED IN THE START OF the Baku FIA GT event being delayed by nearly three hours last Saturday were centred on revisions to the last of four chicanes.

The chicane had to be remodelled and made slower on the demand of FIA circuit inspector Roland Bruynseraede. What race co-promoter Renaud Jeanfils described as "mobile kerbs" made from plastic had to be replaced by old-fashioned tyre stacks.

Bruynseraede explained: "It was just too quick, because the pitlane entrance was straight after. It would have been too dangerous."

The concrete kerbing at two of the other chicanes had already been replaced by plastic strips, commonly known as "sausages" or "baguettes", by this stage. The initial kerbs had been rejected by Bruynseraede when light pressure from his foot broke their tapered edges.

The warm-up on Sunday morning was cancelled and the races delayed because the track was wet after the contractor paid to sweep the circuit had unilaterally decided to hose it down. There was also a short-lived power failure that robbed race control of the use of the circuit security cameras.

Plastic kerbing in the third chicane was ripped up in the second race, which meant a safety-car period while Jeanfils himself used bolt cutters to remove the fixings that had been left in the asphalt.

Jeanfils insisted that some of the problems had been unavoidable. "The red-and-white mobile kerbing, for



Chicane had to be revised for safety

example, was not of the right quantity when it arrived," he explained. "Other problems were our fault, like the wet track. We should have made sure that our instructions were clear, but there will always be communication problems when you are working in a strange country with a different culture."

Jeanfils said the current layout would be retained for next year's Blancpain Sprint Series fixture scheduled for early November. "It is just a question of ironing out some of the little problems," he added.



Tandy (chasing) enjoyed Baku layout

Drivers endorse new Baku track

THE INTERMINABLE DELAYS AT BAKU DIDN'T dampen the drivers' enthusiasm for the 2.72-mile circuit — most reckoned it was a pretty good layout that offered a decent challenge.

Porsche factory driver Nick Tandy, who was driving for the Trackspeed team in Azerbaijan, described it as a "great circuit". "It's got a nice mix of fast and slow corners, and it's pretty difficult," he said. "It's much better than last year's track. It's the kind of track on which the driver can make a big difference, so that has to be good."

Tandy's comments were echoed by McLaren F1 test driver Oliver Turvey, who drove for the Boutsen Ginion squad. "It's got a good flow and is really challenging, especially the chicanes," he said. "It is narrow in places, but that's like any street circuit."

There was, naturally, criticism. Some drivers suggested that the kink before the second hairpin needed to be removed to create another overtaking spot, while most drivers agreed that the chicanes all needed work ahead of next year's event.

CALLAWAY CORVETTE WITHDRAWN

The Callaway Competition Chevrolet Corvette Z06 failed to make it past the opening free-practice session. The car was seriously damaged when Daniel Keilwitz, one half of Callaway's ADAC GT Masters winning line-up, was hit by Edward Sandstrom's Audi. The fuel tank was damaged in the crash, and with no spare, the car shared by Jeroen Bleekemolen had to be withdrawn from the event.

FIA GT MAKES DAMPER DEMAND

Both the Blancpain Sprint Series, the replacement for FIA GT next year, and the Blancpain Endurance Series will demand a homologated damper and three choices of spring for each model of car in 2014. The original GT3 rule was changed for the FIA GT1 World Championship in 2012 and for the BES in 2013.

BMW STABILITY CONTROL BANNED

The stability control system on the BMW Z4 GT3 contender has been outlawed for next season after a vote by the FIA GT technical working group.

FERRARI AND BMW SQUADS MISSING

Two late withdrawals brought the original 30-car Baku entry down to 28 cars. The French Sport Garage Ferrari team and the BMW Team India squad did not attend.

GRAVITY PAIR CROWNED IN PRO-AM

Gravity Charouz Mercedes drivers Andreas Simonsen and Sergei Afanasiev sealed the FIA GT Series Pro-Am title with class victory and sixth overall in the Qualifying Race. The category was won by the Grasser Lamborghini Gallardo LP560-4 driven by Hari Proczyk and Dominik Baumann in the main event.



TESTING YOUR LIMITS!



AUTÓDROMO INTERNACIONAL DO ALGARVE

Opened in 2008, the Autódromo Internacional do Algarve is ideally located in one of the most popular holiday destination in Europe known but its mild climate and being only 30 minutes away from Faro's International Airport.

An internationally acclaimed track with 32 different technical layouts that provide a demanding and unique experience with blind corners, hairpins, double-apex bends and long fast straights.

A modern rain simulation system has been incorporated into the circuit for testing all aspects of performance or tire usage and with a no noise restriction allows 24 hour availability. All these features makes the facility a favourite choice for many motor sports teams and manufacturers.

To date it has hosted major motor sport events such as the FIA GT1 World Championship, Le Mans Series, GP2 Series and already confirmed for the 2014 racing calendar are the FIM Superbike World Championship, International GT Open, Superstars World and Blancpain Sprint Series.



MULTIPLE TRACK CONFIGURATIONS

A versatile and challenging circuit with multiple versions to suit the needs of different varieties of motor racing.



NO NOISE RESTRICTION (24 HOURS TESTS)

Due to its location, the circuit does not have any noise restrictions what makes it ideal for 24 hour testing.



ACCOMMODATION & CATERING PACKAGES

Can offer accommodation and complementary services designed to meet the requirement of individual needs.

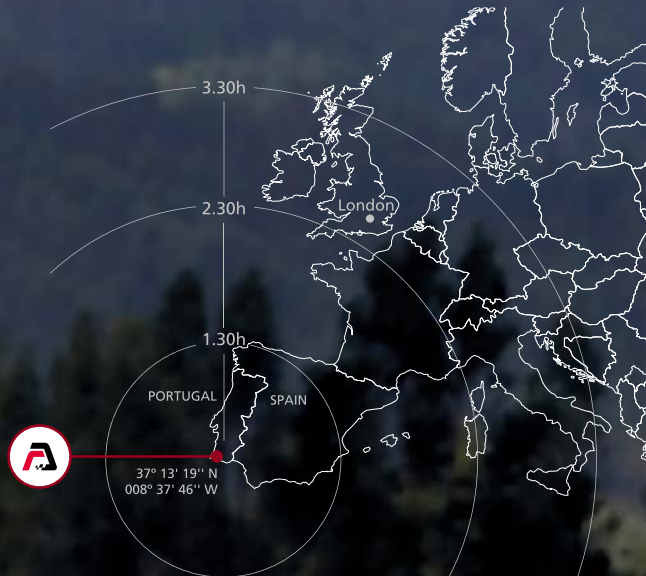

Portimão - Algarve - Portugal
www.autodromodoalgarve.com · info@autodromodoalgarve.com



V8 SUPERCARS PHILLIP ISLAND (AUS), NOVEMBER 23-24 RD 13/14

Holdens best in bruising battles



Tander won race one for Holden Racing...

CIANFLONE/GETTY



JAPANESE SUPER GT

Super GT ran to a double-header sprint race format for its non-championship Fuji finale, with driver combos contesting one 22-lap race each. Real Racing's Kodai Tsukakoshi guided his Honda to victory in the opener, recovering from a bad start from fifth on the 38-car grid to win. Brit James Rossiter (TOM'S Lexus) was fifth. Kazuki Nakajima narrowly lost out to Kazuya Oshima by 0.2s in an all-Lexus battle for victory in the sequel.

SUPER FORMULA

Yuji Kunimoto converted his maiden pole into his first win in the non-points season finale at Fuji. Kunimoto beat World Endurance champion Loic Duval by just 1.6 seconds. The Frenchman started his Team Le Mans-run Swift-Toyota alongside Kunimoto's similar Cerumo machine on the front row, but had to battle back past Impul's Tsugio Matsuda after a slow start.



THREE WINNERS IN THREE RACES AT Phillip Island has set up a fascinating finale to the 2013 championship.

Garth Tander, Craig Lowndes and Jamie Whincup won the races for Holden, and Triple Eight team-mates Whincup and Lowndes look set to hold their own fight for the title in Sydney next month.

On a tough weekend for the Holden Racing Team, during which James Courtney suffered another big crash, Tander took advantage of a controversial clash between Mark Winterbottom's Ford Falcon and Lowndes on the final corner of the first 'leg' of race one to take the lead and the win. No action was taken against either driver involved in the incident, and a protest from Triple Eight against Winterbottom's driving was dismissed.

Lowndes came from well behind to pick his way through the pack and win the second race, while Whincup prevailed in the third.

Whincup lost the series lead after Lowndes's win, but seized it back on a circuit on which he has, by his own high standards, struggled in the past.

The winners apart, the talking point of the weekend was the amount of contact and a series of incidents, the biggest of which involved Courtney. Alex Premat had a tyre go down on his GRM Holden at the flat-out Stoner Corner and, with no steering on wet grass, hammered into an unsuspecting Courtney. Premat had to prise open Courtney's passenger door before he could help

extract him from the car. Thankfully neither driver was badly injured, but such was the impact that both Holdens were almost destroyed.

Fabian Coulthard had a solid weekend in the Brad Jones Racing Holden, while Dick Johnson's duo of Chaz Mostert and Tim Blanchard showed speed after recent engineering changes within the team.

After his runaway race-one win, Tander was not a factor for the rest of the weekend, and while Winterbottom was consistent, team-mate Will Davison had an up-and-down weekend. His FPR Ford was not a factor in two of the races and he looked to be struggling.

On V8 Supercars' first trip to the track since it was resurfaced, and following the recent problems at the MotoGP event, tyres were also a talking point. There were a few issues but no more than in past years.

While the top four drivers can still

win the title, the Sydney finale does appear likely to host an exclusive showdown battle between Whincup and Lowndes.

Whincup has never been a winner there, while Lowndes is looking for his first title in 14 years...

● Phil Branagan

RESULTS

Race 1 1 Garth Tander (Holden Commodore VF), 28 laps in 1h16m53.796s; 2 Fabian Coulthard (Holden), +3.087s; 3 Alex Davison (Ford Falcon FG); 4 Jamie Whincup (Holden); 5 Mark Winterbottom (Ford); 6 Tim Blanchard (Ford). **Race 2 1 Craig Lowndes (Holden)**, 23 laps in 38m02.553s; 2 Whincup, +1.001s; 3 Shane van Gisbergen (Holden); 4 Chaz Mostert (Ford); 5 Coulthard; 6 Winterbottom. **Race 3 1 Whincup**, 23 laps in 42m22.900s; 2 Winterbottom, +0.885s; 3 Lowndes; 4 Jason Bright (Holden); 5 Coulthard; 6 Will Davison (Ford). **Points 1 Whincup, 2815**; 2 Lowndes, 2795; 3 Winterbottom, 2691; 4 W Davison, 2592; 5 Coulthard, 2393; 6 Tander, 2259.

...while team-mate Courtney (right) crashed



CIANFLONE/GETTY



L-r: Beche, Turvey, Panciatici and Ragues vied for the title

LMP2 CHAMPIONSHIP POSITIONS

1	NELSON PANCIATICI/PIERRE RAGUES	85
Signatech ORECA-Nissan 03		
2	PIERRE THIRIET	77
TDS Racing ORECA-Nissan 03		
3	OLIVER TURVEY/SIMON DOLAN	71
Jota Sport Zytek-Nissan Z11SN		
4	JONATHAN HIRSHI	69
TDS/Murphy ORECA-Nissan/Status GP Lola-Judd/BMW		
5	BRENDON HARTLEY	64
Murphy Prototypes ORECA-Nissan 03		
6	MATHIAS BECHE	62
TDS Racing ORECA-Nissan 03		

GTE CHAMPIONSHIP POSITIONS

1	JOHNNY MOWLEM/MATT GRIFFIN	114
Ram Racing Ferrari 458 Italia		
2	CHRISTIAN RIED	80
Proton Competition Porsche 911 GT3-RSR		
3	NICK TANDY	70
Proton Competition Porsche 911 GT3-RSR		
4	MARCO CIOCI/PIERGIUSEPPE PERAZZINI/FEDERICO LEO	63
AF Corse Ferrari 458 Italia		
5	GUNNAR JEANNETTE/FRANKIE MONTECALVO	63
Ram Racing Ferrari 458 Italia		
6	ANDREA BERTOLINI/JOEL CAMATHIAS	61
JMW Motorsport Ferrari 458 Italia		

LMPC CHAMPIONSHIP POSITIONS

1	PAUL-LOUP CHATIN/GARY HIRSCH	115
Team Endurance Challenge ORECA-Chevrolet FLM09		
2	SOHEIL AYARI/ANTHONY PONS	98
Team Endurance Challenge ORECA-Chevrolet FLM09		
3	ALEX LOAN	33
Team Endurance Challenge ORECA-Chevrolet FLM09		

GTC CHAMPIONSHIP POSITIONS

1	FABIO BABINI/KIRILL LADYGIN/VIKTOR SHAITAR	100
SMP Racing Ferrari 458 Italia GT3		
2	ANDREA RIZZOLI/LORENZO CASE/STEFANO GAI	76
AF Corse Ferrari 458 Italia GT3		
3	ANDREW SMITH/OLLIE MILLROY	67
Ecurie Ecosse BMW Z4 GT3		

LMP2 WINS

THIRIET/BECHE	2
PANCIATICI/RAGUES	1
TURVEY/DOLAN	1
HARTLEY/HIRSCHI	1

LMP2 POLES

TURVEY	4
HARTLEY	1

LMP2 FASTEST LAPS

HARTLEY	3
TURVEY	2

POINTS SYSTEM EXPLAINED

In each race: 25-18-15-12-10-8-6-4-2-1, plus a point for the crew on pole.
RACES: Silverstone, April 13; Imola, May 18; Red Bull Ring, July 20; Hungaroring, September 14; Paul Ricard, September 28.



FOR IN-DEPTH RESULTS
forix.autosport.com

ELMS REVIEW 2013

Signatech takes revived crown

The French were on form as the ELMS got itself back on its feet with a promising 2013. By **GARY WATKINS**



Styrian Alpine: champs lead the way in Austria

The European Le Mans Series bounced back in 2013. After a premature end in 2012, it returned under new management and with a new format, and proved, even if it wasn't quite in the rudest of health, that there is a place for a Europe-only series in the endurance racing pyramid under the Le Mans 24 Hours and the World

Endurance Championship. The shift in management to WEC boss Gerard Neveu and his group resulted in an average car count of more than 25 across the five three-hour races. Sure, something approaching half of those entries was spread across the GTC class populated by GT3 machinery and the one-make prototype division for the ORECA-Chevrolet FLM09, but the ELMS still looked like a coherent and worthy series.

The halving of the duration of the races wasn't universally popular, but it made sense for a relaunch year during which the ELMS piggy-backed the World Series by Renault bill for three events. Neveu, always one to listen to his constituents, reacted and has increased the races to four hours for 2013. Again, a sensible move.

HOW IT WAS WON

Consistency was the name of the game in the ELMS in 2013. A non-score or a couple of weak results were always going to be hard to overcome, and that proved to be the case for both the French TDS Racing squad and the British Jota Sport team with their respective ORECA-Nissan 03 and Zytek-Nissan Z11SN LMP2 challengers.

That left the way clear for the Signatech duo of Nelson Panciatici and Pierre Ragues and their Alpine-badged ORECA-Nissan to take the title in the top LMP2 class. Both Jota, with prototype newcomer Oliver Turvey and Simon Dolan driving, and reigning champion TDS, in whose ORECA Pierre Thiriet was partnered first by Jonathan Hirschi and then team returnee Mathias Beche, will look back on 2013 as an opportunity lost.

The small but well-funded TDS squad, which unceremoniously sacked Hirschi after Silverstone to bring back Beche, was the only team to take more than one overall victory, but its title challenge started to come off the rails in Hungary when Beche tagged a spinner at the start, and then hit the buffers at the Paul Ricard finale.

Entering the season closer equal on points with Signatech, TDS looked on its way to the title before Beche lost a rear wheel, the resulting stop for repairs leaving them eighth and Thiriet



Mowlem/Griffin claimed GTE spoils

second in the final points table.

Jota triumphed in the wet, truncated relaunch race on the WEC undercard at Silverstone, but a non-finish when Dolan was caught out by a backmarker at Imola and a problem with the pitlane speed limiter at Spielberg, which left the car fourth at the finish, hurt the team. The championship was all but gone before a troubled run to third at Ricard.

Signatech, meanwhile, continued to notch up the points through the season in the only Michelin-shod P2 runner against the Dunlop hordes. Panciatici and Ragues never finished lower than fourth and had two seconds to go with their solo victory at the Hungaroring. A conservative run at Ricard yielded them the title once TDS had been delayed.

Consistency also won the other class that mattered – consistent dominance, that is, by the new-for-2013 Ram Racing squad in the pro-am GTE class. And dominant it damn well should have been with the best driver line-up in class in Johnny Mowlem and silver-rated Matt Griffin, who as the ‘am’ (the inverted commas are most definitely required) stood head-and-shoulders above his peers.

They triumphed in their Ferrari 458 Italia in three of the five races and finished second on the other two occasions. They only lost out when the rain came, missing out on victory at Silverstone and at the Hungaroring when the Proton Porsche, in which Nick Tandy starred, took the honours. Otherwise, it was like shooting fish in a barrel, but that said Ram looked the part and didn't make many mistakes.

STANDOUT PERFORMERS

If you're looking for a star from the 2013 ELMS, then Turvey jumps out. The Brit took to prototype racing straightaway, as you would expect of a driver of his calibre and experience, but he showed his pace at every turn and didn't put a foot wrong.

SOMETHING TO REMEMBER

Brendon Hartley's pace has never been in doubt, but the way he drove around a major braking issue to give the Murphy Prototypes team its first victory at Ricard proves that he has a big future. That's something that Porsche, his likely employer next year, has recognised.

SOMETHING TO FORGET

A wet Silverstone race, red-flagged the moment 70 per cent duration had been reached so that full points could be awarded, wasn't the ideal restart. Yet the ELMS weathered the storm and, in the end, it didn't matter.

WHAT NEXT?

The ELMS isn't suddenly going to have the 40 odd cars that it enjoyed as the LMS in pre-WEC days, but then the series bosses know that's not realistic. Steady growth from the firm relaunch platform that was 2013 is the target. ❄

THE BATTLE FOR GTC AND LMPC

They don't have a place on the grid for the Le Mans 24 Hours, but the LMPC and GTC classes surely have a legitimate place in the ELMS. It has been correctly billed, to the chagrin of some competitors, as a feeder series, so entry-level prototype and GT classes make sense. At least on paper.

The LMPC division didn't appear to make much sense for owners of ORECA-Chevrolets sitting gathering dust in workshops around Europe. The class was more or less the domain of the grandly titled Team Endurance Challenge, an in-house ORECA arrive-and-drive squad. Only on two occasions did an additional car turn up.

Alpine junior driver Paul-Loup Chatin and Gary Hirsch rightly claimed the title with three wins, though a starting issue almost ripped it away from them at Ricard.

There were more takers in GTC, though bizarrely a team that wasn't on the grid at the Silverstone



Hirsch joined Chatin as LMPC champion

opener ended up dominating. The Franco-Russian SMP Racing squad turned up at Imola with its fleet of Ferraris and claimed victory with Fabio Babini and handy Russians Kirill Ladygin and Viktor Shaitar. They repeated the trick at each of the remaining rounds to take a clear championship victory.

TOP 10 DRIVERS



1 OLIVER TURVEY

A faultless year ultimately went unrewarded, though Turvey did lay the foundations of a strong reputation in a discipline new to him. His run of four poles from five races was particularly impressive, given that more often than not he did more than one lap good enough to top the times.

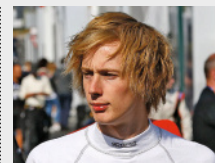

2 BRENDON HARTLEY

The quickest P2 man in the ELMS alongside Turvey produced some stirring performances. He was mega in the wet at Silverstone (before going off) and with dodgy brakes at Ricard.



3 MATHIAS BECHE

There's something understated about Beche. That goes for his neat and tidy driving and his personality, but his P2 exploits proved why he was picked up by Rebellion for the WEC.

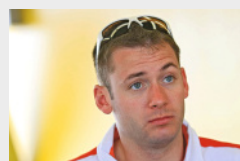

4 NICK TANDY

Never likely to win much with the Proton line-up, Tandy still proved why Porsche was right to sign him. His drive in changing conditions at Silverstone was superlative and he was the thorn in Ram's side.

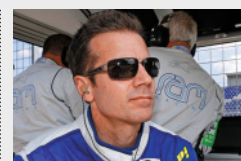

5= JOHNNY MOWLEM

Griffin did all the hard work courtesy of ELMS sporting rules, but Mowlem was the quicker driver, generally banging in a lap faster than his team-mate as he cruised their Ferrari to GTE victory.



5= MATT GRIFFIN

Ram's star signing as a silver worth his weight in gold was central to the ambitious Ram team's run to the GTE title. More often than not he drove like the gold he will be in 2014.



7 NELSON PANCIATICI

The Frenchman didn't quite look the star-in-the-making that he appeared in his maiden season in prototypes in 2012, but he's ultra-quick on his day.



8 PIERRE THIRIET

Probably the best silver in P2, Thiriet keeps on improving and edging closer to the pros. It was he, and not Beche, who proved decisive in victory for the TDS squad at the Imola round.



9 PIERRE RAGUES

Downgraded to silver status over the winter, Ragues often drove like one, but this journeyman driver starred in drying conditions on the way to Signatech's only victory in Hungary.



10 FABIO BABINI

This underutilised talent made the most of the chance given to him by SMP in GTC to reacquaint the world with the speed that once made him one of the world's top GT drivers.



SUPERSTARS REVIEW 2013



Charge of a champion

Series veteran Gianni Morbidelli looked out of it after the first three rounds but the Audi ace fought back. By **ANDREW VAN LEEUWEN**

CHAMPIONSHIP POSITIONS

1	GIANNI MORBIDELLI (I) Audi Sport Italia Audi RS5	232
2	GIOVANNI BERTON (I) BMW Dinamic BMW M3	190
3	VITANTONIO LIUZZI (I) Romeo Ferraris Mercedes C63 AMG	189
4	THOMAS BIAGI (I) Romeo Ferraris Mercedes C63 AMG	188
5	LUIGI FERRARA (I) Roma Racing Mercedes C63 AMG Coupe	127
6	MAX MUGELLI (I) BMW Dinamic BMW M3	98
7	FRANCESCO SINI (I) Solaris Chevrolet Camaro SS/Lumina CR8	76
8	ANDREA BACCI (I) CAAL Mercedes C63 AMG	66
9	MAURO TRENTIN (I) BMW Dinamic BMW M3	57
10	ANDREA LARINI (I) Adria Jaguar XFR/ Audi Sport Italia Audi RS5	44
11	LAURENS VANTHOOR (B) Audi Sport Italia Audi RS5	34
12	FABRIZIO GIOVANNARDI (I) Petri Corse Porsche Panamera S	33
13	DAVIDE DI BENEDETTO (I) Audi Sport Italia Audi RS5	22
14	RAFFAELE GIAMMARIA (I) CAAL Mercedes C63 AMG	20
15	RENAUD KUPPENS (B) Giudici BMW M3	20
16	'DIABOLIK' (I) Adria Jaguar XFR	17
17	FRANCESCO ASCANI (I) Todi BMW M3	16
18	ROBERTO BENEDETTI (I) RC Cadillac CTS-V	16
19	DOMENICO SCHIATTARELLA (I) Solaris Chevrolet Lumina CR8	16
20	GIANNI GIUDICI (I) Giudici BMW M3	13

FOTOMORALE

WINS

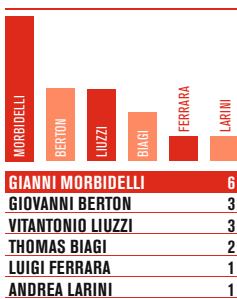

POLES

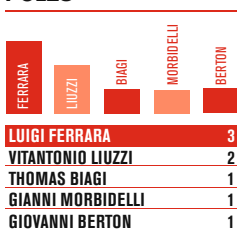

FASTEST LAPS

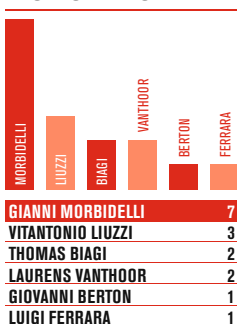

Liuzzi: best Merc driver

SUPERGRID 2013

Qualifying positions not included when a driver was unable to set a time due to any problem where the driver is not at fault. Positions taken before any grid penalties applied * missed races

1	LIUZZI	2.3
2	FERRARA*	2.5
3	MORBIDELLI	4.1
4	BIAGI	4.2
5	BERTON	4.7
6	MUGELLI	6.0
7	GIOVANNARDI*	6.2
8	SINI*	8.1
9	A LARINI*	8.2
10	BACCI	9.4
11	TRENTIN	10.1
12	DIABOLIK*	11
13	BACCARELLI*	11
14	ASCANI*	13.2
15	BENEDETTO*	14
16	GIUDICI*	15

POINTS SYSTEM EXPLAINED

20-15-12-10-8-6-4-3-2-1 to top 10 finishers in each race. One point for pole position; one point for fastest lap; one point for starting.

RACES: Monza, April 7; Brno, May 19; Slovakia Ring, June 9; Zolder, June 23; Algarve, July 21; Donington Park, September 1; Imola, September 29; Vallelunga, October 13.

The 2013 instalment of the Superstars International Series was one of two parts; the first being dominated by Mercedes, the second an Audi romp that led to Gianni Morbidelli winning another title.

Three rounds into the series, it seemed impossible that Morbidelli and his Audi Sport Italia RS5 would wind up winning the title. At that stage, the Romeo Ferraris Mercedes pair of Thomas Biagi and Vitantonio Liuzzi were dominating, while an overweight Audi, and a combination of fast, open circuits left Morbidelli 53 points off the champions lead.

But a dramatic fightback, aided by a pre-Zolder relaxation of Audi's Balance of Performance and a host of more RS5-friendly circuits in the second half of the season, helped the veteran storm to the title.

HOW IT WAS WON

There were two key components to Morbidelli's success. The first was the mature way he tackled the first three race meetings of the season, where the Audi was off the pace of the Mercedes.

While clearly frustrated with the situation, Morbidelli kept calm. He kept the results ticking over, the points coming in, and didn't rack up

unnecessary DNFs by throwing the car off the road or over-driving.

It left him just close enough to the early frontrunners that when the more Audi-friendly circuits like Zolder, Algarve and Donington rolled around, Morbidelli was able to clamber his way back into the game with a stunning series of wins (six from the last 10 races).

The second key component was Imola. Had that weekend been dry, Morbidelli would almost certainly have dropped points to the two Romeo Ferraris Mercedes drivers, as well as BMW's Giovanni Berton. It might not have cost him the championship, but it would have given him a lot more to do at the Vallelunga finale.

It was a moment of good fortune for Morbidelli, but what's even more important is his smart driving in the first six rounds had left him in a position to capitalise on it.

STANDOUT PERFORMERS

It was expected that the 'big names' (Liuzzi, Morbidelli and Biagi) would dominate in 2013, but it wasn't always the case.

Berton was one example of a young driver who really put his name on the map with some stunning drives. While the Dinamic BMW M3 was rarely a match for the Mercedes or Audis, Berton was sublime throughout the season. He won the second races at both Brno and Slovakia Ring (both started with the top eight reversed),



Veteran Morbidelli needed all his guile to overcome Mercs

GERARDO BENFENATI



Morbidelli (r) took a double at Zolder to kickstart his title bid

TALKING POINT

Whenever you have a series that isn't a spec formula, parity is always going to be an issue. And in 2013, what constituted a level playing field was quite often the talk of the paddock.

What complicates the matter severely is the four-wheel-drive system in the Audi RS5. It makes it very difficult to slow the Audis down at places like Zolder and Vallelunga, where the corner profiles play directly into the hands of a car capable of generating so much grip. And if it rains, forget about it.

My neutral opinion on the matter is that organisers did a good job with the parity adjustments. Each of the 'Big Three' (Audi, Mercedes and BMW) were fast at the circuits that you would expect them to be fast. The parity adjustments caused plenty of grumbling from the drivers during the season, but hey, that probably just means it was working.

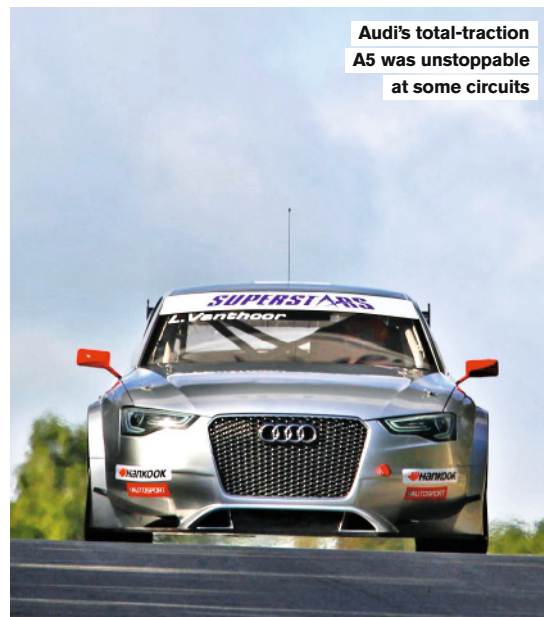

Audi's total-traction A5 was unstoppable at some circuits

and then put in one of the absolute drives of the season to win from pole in race one at Vallelunga.

Another lesser-known driver to really show his talent was Luigi Ferrara. The 31-year-old did a stunning job for the one-car Roma Racing Mercedes squad, and ended the season with more poles than anyone else. Had it not been for an incredibly unlucky series of water-pump failures he would have won more races, and may have even been a genuine title contender.

SOMETHING TO REMEMBER

There was no shortage of impressive driving, but the most memorable display of brilliance came courtesy of Liuzzi at the Slovakia Ring.

With a hump in the back straight at the circuit having caused problems with cars literally taking off, the organisers placed a rather agricultural chicane in the middle of the road. It consisted of two barriers placed across the centre of the track, and the more safety-conscious among the drivers didn't like it.

Liuzzi, however, loved it. He said it reminded him of Monaco, and he attacked it hard. In qualifying he went through flat in fifth at a smidge over 220km/h. In the first race, he was visibly much faster through the chicane than the rest of the field, the key to a dominant win.

SOMETHING TO FORGET

Race one at Imola is surely one Biagi will be hoping to forget in a hurry. With the rain falling, giving the Audi RS5 a huge advantage, Biagi needed to just score well enough to keep the title fight properly alive for the last race. Instead, he tried way too hard to keep Morbidelli behind, spinning on the last lap and effectively gifting the title to his rival. It was a crucial, and highly unnecessary, mistake.

WHAT NEXT?

There are some exciting changes on the horizon for next season, including a new race format, and talk of a new class. Nothing is confirmed yet, but if all goes to plan, there is a lot to like about the new direction. 🏁

TOP 10 DRIVERS



1 GIANNI MORBIDELLI

It was a superb season from the veteran Italian. Early on, when the car wasn't capable of winning, Morbidelli made sure he scored well. When the car did get into its stride, he was up to the task of winning, taking six victories in the season's final 10 races to secure his fourth drivers' title.



2 GIOVANNI BERTON

The BMW Dinamic M3 wasn't the fastest car over the balance of the season, but Berton was one of the fastest drivers. He took it to the big names over and over again.



3 VITANTONIO LIUZZI

Liuzzi showed his quality on a number of occasions, such as at the Slovakia Ring, and with a bit better luck (mechanical DNFs cost him dear) he might have won the title.



4 THOMAS BIAGI

Drove superbly to match his Romeo Ferraris Mercedes team-mate Liuzzi early on in the season, but didn't do a good enough job scoring when the car wasn't capable of winning.



5 LUIGI FERRARA

The 31-year-old Ferrara was one of the stars of the season. He did a great job for what was a one-car team, and he would have won more races had mechanical failures not got in the way.



6 FRANCESCO SINI

Sini did a good job developing the brand new Solaris Chevrolet Camaro as the season progressed, and he deserved his brace of podium finishes at the last two events.

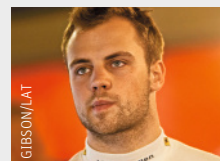

7 LAURENS VANTHOOR

The Belgian only did one event, his home event at Zolder, but he made a huge impact. Would have won race two had he not moved over for Morbidelli.



8 MAX MUGELLI

Was a consistent performer throughout the season, and was very close to BMW Dinamic team-mate Berton's pace on more occasions than anyone would have predicted pre-season.



9 FABRIZIO GIOVANARDI

His half-season in the Petri Corse-run Porsche Panamera S was littered with mechanical problems, but when the car was working 'Gio' produced the goods each and every time.



10 ANDREA LARINI

There's never a dull moment when this guy is around. He missed a lot of races thanks to the failed Jaguar experiment, but he was right on the pace when he joined Audi at Vallelunga.

SAVE UP TO 32%

AND GIVE THE GIFT THAT LASTS ALL YEAR



Autosport
SAVE UP TO 18%
12 issues for £34.99
26 issues for £74.45



F1 Racing
SAVE 32%
12 issues for £39.99



FourFourTwo
SAVE 28%
12 issues for £39.99



Stuff
SAVE 28%
12 issues for £39.99



What Car?
SAVE 31%
13 issues for £44.99



Classic & Sports Car
SAVE 29%
12 issues for £39.99



Autocar
SAVE UP TO 25%
12 issues for £29.99
26 issues for £63.95



Practical Motorhome
SAVE 27%
13 issues for £39.99



Motorsport News
SAVE UP TO 22%
12 issues for £28.95
26 issues for £60.95

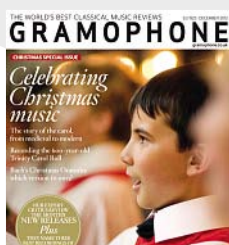

Gramophone
SAVE 23%
13 issues for £49.95



Practical Caravan
SAVE 27%
13 issues for £39.99



What Hi-Fi?
Sound and Vision
SAVE 31%
13 issues for £44.99



Champions Matchday
SAVE 16%
12 issues for £30.00

Call **0845 124 7040** now or order online at
www.themagazineshop.com/xpa13



AUTOSPORT subscribers receive a free **AUTOSPORT Digital Edition** subscription & unlimited access to **AUTOSPORT.com**

For other great print and digital offers visit www.themagazineshop.com/xpa13



SUBSCRIBER BENEFITS

- Save up to 32% on the shop price
- Exclusive Christmas prices
- Free gift card for you to send to your friend or relative
- Spread the cost of Christmas when you pay by Direct Debit*

* Call **0845 124 7040** or visit www.themagazineshop.com/xpa13 for details on how to save more when you choose to pay by Direct Debit.

When ordering quote code **XPA13**

ORDER FORM

(FOR PRINT ONLY SUBSCRIPTIONS)

To be sure your gift starts promptly after Christmas, fill in the form below and return your order to us by 10th December, 2013 at:

Haymarket Magazines - Christmas,
FREEPOST RSBZ-GBES-RRKB, PO Box 326,
Sittingbourne, ME9 8FA or call the Order Hotline on
0845 124 7040 (quote XPA13) or visit us at
www.themagazineshop.com/xpa13

How to order:

- 1 Please complete the order form in BLOCK CAPITALS.
- 2 Complete the section headed 'Your Details'
- 3 Enter the name, postcode and telephone number of the person who will receive a magazine subscription as a gift.
- 4 Enter the names of the magazines in the space provided.
- 5 This form can be photocopied for further orders.

YOUR DETAILS (BLOCK CAPITALS PLEASE - MUST BE COMPLETED)

This subscription is: A GIFT OR FOR ME

Magazine title/s* _____ (*if subscribing for yourself)

Title _____ Name _____ Surname _____

Address _____

_____ Postcode _____

Telephone _____

Email _____

Mobile _____

I wish to pay for a total of _____ subscriptions.

ORDER TOTAL (please complete) £ _____

GIFT SUBSCRIPTION DETAILS (BLOCK CAPITALS PLEASE)

Magazine title/s _____ No. of issues _____

Title _____ Name _____ Surname _____

Address _____

_____ Postcode _____

Telephone _____

PAYMENT DETAILS

I enclose a cheque made payable to Haymarket Media Group for £ _____

Please debit my: **Mastercard/VISA/Amex/Maestro/Diners** for the amount £ _____

Card No.

Valid from Expiry date Issue no. (Maestro only)

Signature _____ Date _____

TERMS & CONDITIONS: This is a UK only offer - for overseas offers please visit www.themagazineshop.com or call +44 (0) 1795 418 660. For all gift orders received by 10th December 2013, we will post a special gift card for you to send on to the recipient letting them know about their gift subscription. Subscription orders received after 10th December will still receive a gift card but we cannot guarantee that it will arrive before Christmas. The gift subscription will begin with the first available issue on-sale in 2014. A bundle subscription is set-up for an individual user only and components are not transferable. Details on how to access digital editions will be sent via email. Final closing date for orders is 31st January 2014. All savings are based on the UK cover price and are correct as of 1st September 2013. Should you wish to cancel your subscription it will be cancelled on expiry of the current term which will not be refundable, other than in exceptional circumstances. **Haymarket Media Group Ltd** uses a best-practice layered Privacy Policy to provide you with details about how we would like to use your personal information. To read the full privacy policy please visit our website www.haymarket.com/privacy or call us on 08448 482 800. Please ask if you have any questions as submitting your personal information indicates your consent, for the time being, that we and our partners may contact you about products and services that will be of interest to you via post, phone, e-mail and SMS. You can opt-out at ANY time by emailing the datacontroller@haymarket.com or by calling 08448 482 800.

Promo code: XPA13

Penske & Watson reunited

56

Roger Penske and John Watson don't often get together, so **ANDREW VAN DE BURGT** jumped at the chance to join them for a look back at their successful 1976 season

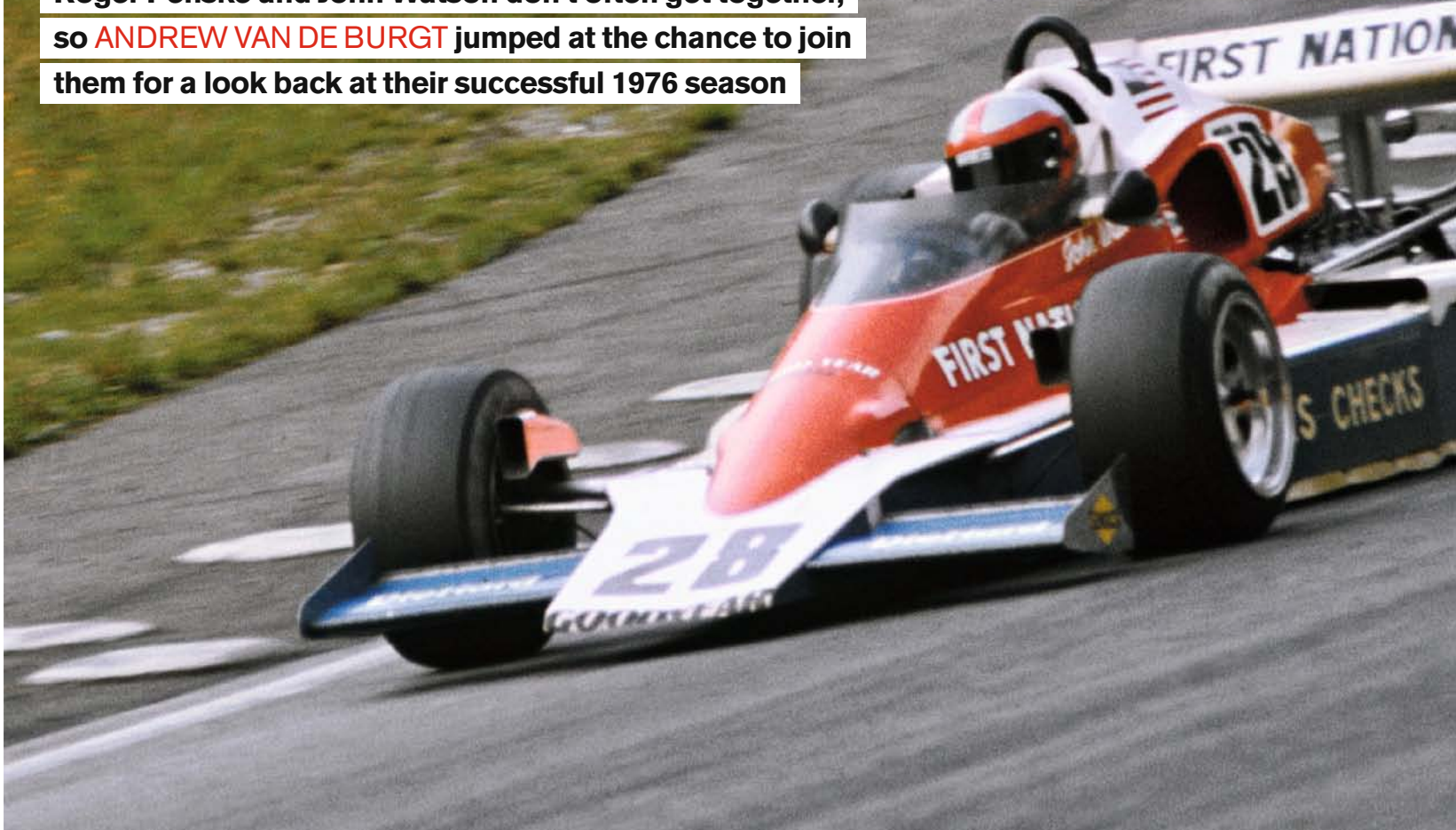



'The Captain' and his charge John Watson

The day it all came good: Watson and Penske won at the Osterreichring in '76

Some great bands only get together for really special occasions. Roger Waters and Dave Gilmour put their differences aside to reunite the classic Pink Floyd line-up for Live 8 in 2005, while Robert Plant was persuaded to squeeze back into his leather trousers for a one-off Led Zeppelin reunion to celebrate the life of Atlantic Records founder Ahmet Ertegun in 2007.

If Roger Penske was a rock star he would surely have fronted one of the biggest bands in the world before enjoying a successful solo career during which he teamed up with a series of other legends for interesting, and commercially rewarding, side projects.

These days he might be well into his seventies, but through his NASCAR and Indycar programmes, not to mention his multi-billion dollar business empire, he's still as active as ever.

So when an email landed in my inbox announcing that Penske would be the Motorsport Industry Association's guest of honour at its most recent dinner, it seemed like a great opportunity to get 10 minutes with one of motorsport's most successful team owners.

And then, completely by chance, John Watson rang. A few calls and emails later and Wattie was on the MIA's guestlist and the first meeting between the man who scored Penske's only Formula 1 win – in Austria in 1976 – and 'the Captain' since 1994, was on.

Watson: "I remember the last time. Roger invited Murray Walker and myself over to Nazareth, Pennsylvania, to see an oval race, which was super-close to Reading where the

team was based at that time."

Penske: "I think it's amazing. We had been close to each other at different times, but it is hard to believe that we haven't connected. It's a shame that as much time that I have been spending over here that I haven't had more time to connect."

The story of the 1976 season has been a hot topic this year thanks to Ron Howard's highly successful *Rush* motion picture. But the story of the Watson/Penske win at the Osterreichring that year has barely been mentioned.

Penske: "In Austria that was a combination of probably three years of hard work and getting a driver who understood us as a team and had the talent to be the best. It was ironic that Mark [Donohue] passed away in Austria in an accident, and a year later we were back, and won the race."

Watson: "Penske came into F1 in 1974 with the PC1 and Mark. In '75 I was driving for John [Surtees], and I think we had missed a couple of grands prix. At that point drivers could walk ▶

"We wanted to hire the best – John was that man. We've always been careful with the people we hire" ROGER PENSKÉ



Watson beats poleman Hunt off the line at Austrian start

► around a lot more freely – you could walk into somebody's garage and talk. I wasn't sure what Mark wanted to do, in terms of staying in Europe or staying in F1. I thought he would want to do more back in the States, so it was indicated that if there was an opportunity would I be interested?

"Following the tragedy of Austria '75, contact was made and then I ended up driving for Roger's team at Watkins Glen at the end of '75 and for the full '76 season. For me, it was the best opportunity that I'd had in my career to date.

"During that first race at the Glen, I went down to do the warm-up in the PC3 when something happened in the car and we couldn't repair it.

And the spare car was PC1, which I think I had only ever sat in it, but never driven. The seat didn't fit me particularly well. And at the end of the race I had a pain in my right-side ribs.

"We were staying on after that race to do some testing with the PC3, but I was in real pain all through that test. Years later I was having a medical and the doctor said, 'When did you break your ribs?' 'Never,' I said. 'Yes you have, you've got two broken ribs!' But that's what you did, jump in the baby, get out there and ride it."

Penske: "I did not make that decision out of hand. We wanted to hire the best we could and John was that man. We have always been really

careful with the types of people we hire in the team, because the driver becomes part of your family. And even though you might pay a driver, at the end of the day, that becomes secondary to the ingredients that connect him to the team. And we felt that John would fit that role."

Watson: "Nobody really understood aerodynamics back then, certainly not in the way they do today, and nobody realised how much influence the tall airbox was having on the rear wing. We lost the balance of the car when the regulations changed, and in effect Roger commissioned Geoff Ferris to start building PC4. When it was launched initially it came out with

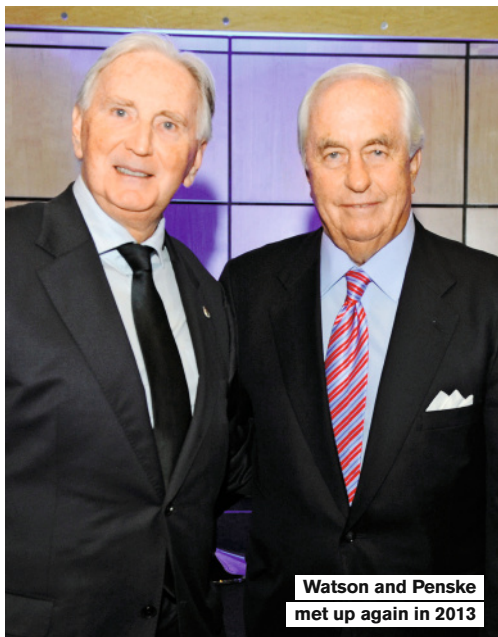

Watson and Penske met up again in 2013

WHAT WATTIE DID NEXT: 1977

For 1977, Formula 1's governing body decided that all teams should be two-car entries. With his business interests in the States demanding so much of his time, Penske felt unable to give Formula 1 the attention it required and the programme was curtailed in late 1976. It left Watson without a ride just months ahead of the start of the season. But all was not lost...

"I got a call from Roger, which was in the middle of the night UK time," he recalls. "I think it was one of the most difficult decisions that he ever had to tell a driver. It was a shock to me.

"We were just at the cusp of a technological explosion, but we didn't realise at the time. Colin Chapman was just getting the idea of how ground-effect was going to be applied. So it was going to be a massive expansion in terms of operation, which therefore meant a massive expansion in funding. I say this because this is what I understand; I think Roger's

team gave his sponsors very good value for money.

"And suddenly you have got to up your game, double the size of your team, and it meant there was going to have to be a minimum of three cars – two race cars and one spare – or maybe four cars depending on the status of drivers employed. That realisation probably led to the decision to say, 'Right, stop now and quit while we are ahead'. It would have been hard, I think, for Roger to run the team from North America.

"It was a huge disappointment to me. The following morning I got on the phone to Heinz Hofer who was down in Poole. At that point the principal objective was to try to get me into another seat. I think there might have been an opportunity at Shadow. But Heinz got on the phone to Bernie [Ecclestone], and said John needs to speak to you about a drive next year – he thought we were taking the piss! I had to explain to him what had happened and Bernie still didn't believe us.



Watson got the job done for Penske's team...

GETTY



...but the boss could not commit beyond 1976

LAT

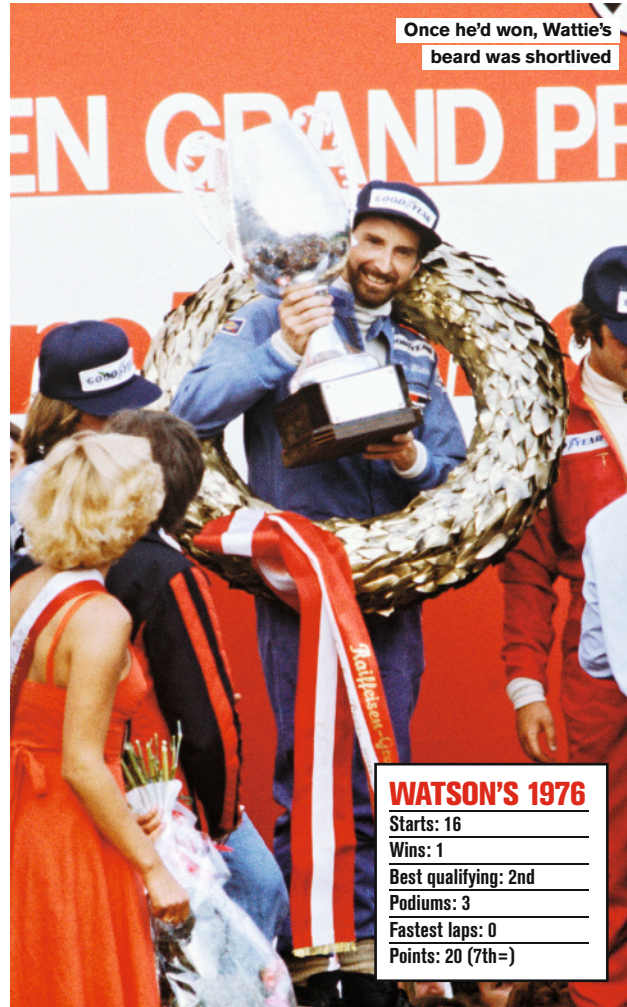

Once he'd won, Wattie's beard was shortlived

WATSON'S 1976

Starts:	16
Wins:	1
Best qualifying:	2nd
Podiums:	3
Fastest laps:	0
Points:	20 (7th=)

"I think Roger set standards in F1 but you were quite likely to see him in the garage with a broom" JOHN WATSON

fact in many cases it was the unfair advantage we had. Everyone would have a March or have a Lola or whatever it was in those days, and we could build something that was better because we had the capability.

"I certainly feel that John was instrumental in kicking off our career. And I can say that we won in every sport and every discipline, and John was the one who delivered the Formula 1 win for us."

Watson: "The thing with Roger was that he was on a path, a direction, a career, where motorsport was a tool for his commercial aspirations. I think he set standards in F1. I might be wrong, but I think when people like Ron Dennis saw what Roger did from a presentation perspective, it inspired him to go on and do what he has done. To be around somebody as dynamic and as inspirational, as ambitious and as driven, I mean I don't know if any of those qualities rubbed off on me, but to be around somebody like that is an opportunity for you to develop as a person not just as a racing car driver.

"When Roger came to a grand prix it was precious time he was taking out of a very busy commercial schedule. And on the weekends when there wasn't a grand prix he was going somewhere else. The thing is with Formula 1 is that it's very much a European formula. And while we were racing in the States it was mainly seen as a European championship. Everything was run out of Poole. So I would drive up and down between every grand prix and go and have a chat, talk about what we had done and what we might do for the following race. It was a family.

"The one thing about Roger was that he was just one of the team. You were quite likely to see him in a garage with a broom if he thought something looked untidy!"

a full-width sort of Ferrari-style front wing. We never could really get it to perform satisfactorily. Roger would look down the paddock and say, 'Well that's working and that's working.' And he said, 'Why don't you put a spacer in between the gearbox and the engine?' So we lengthened the wheelbase, and split the front wing and suddenly the car was transformed and it became a really nice car to drive and very competitive.

"In those days we ran Goodyear tyres and making two that had the same circumference was a real skill. The top teams always had the best set of balanced tyres. But we had a really fantastic set of tyres in Austria and that's partly why the car

performed so strongly there. PC4 was a good car that really was setting the whole team up for a competitive 1977 season."

Penske: "We were a small, dedicated group and we thought that we could survive in the very difficult environment of F1 at that point. It was obvious that we had a very competitive car, but the question was, living in America and trying to race in F1 in the US and trying to hold a job that I had at that point and the family was maybe a little more than I could do. But the by-product of all of that was Penske Cars in Poole. Penske Cars became a foothold for us up to, I think, 1999. We built six Indy 500 winners out of that shop. In

"Eventually he said, 'OK, come over to the flat.' So I went over to see Bernie and sat down and eventually I was signed to drive for Brabham. But there was a slight issue; for '77 Parmalat were very keen on having an Italian driver, but Bernie never wanted a sponsor to dictate a driver. He wanted to be in control.

"Clay [Regazzoni] was scheduled to arrive in London and Herbie [Blash] was meant to meet him at the airport. So Bernie rang Herbie and said, 'I've signed John. I need you to go to the airport and meet Clay and in the best manner as possible say we are terribly sorry but John signed last night and there is no opportunity for you.' It was a typical Bernie deal. He loved it!"

Watson led four races for Brabham in 1977, but failed to win any of them thanks to misfortune. A switch to McLaren for 1979 eventually took him to the brink of the 1982 title, but he fell short by just five points.

Penske has racked up scores of wins and titles in Indycar, NASCAR and sportscar racing in the years since 1977, but despite building its Indycars in the UK until 1999, it has never run a full season of European-based racing again.

Watson was fast but unlucky at Brabham





Putting six Brits to the test

The 2013 McLaren AUTOSPORT BRDC Award was a hard-fought contest as the judges looked for the next British motorsport star. **KEVIN TURNER** explains how the six finalists were assessed

The process for selecting the best up-and-coming British motorsport talent has evolved a lot over the history of the McLaren AUTOSPORT BRDC Award. Inaugural winner David Coulthard was simply chosen on the back of his fine Formula Ford performances in 1989, but the system is now rather more complex and analytical.

This year's judges – BRDC president Derek Warwick, double British Touring Car champion Jason Plato, former GT ace and Award winner Andrew Kirkaldy, McLaren head of vehicle engineering Mark Williams, leading commentator Ian Titchmarsh and yours truly – had access to a fantastic amount of data.

Here's how we worked towards the decision that will be announced at the AUTOSPORT Awards on Sunday.

SELECTING THE BEST

The first part of the process each year is selecting the six finalists who will be put through their paces at Silverstone.

The 2013 records of dozens of eligible drivers (those aged between 16 and 22 on January 1 this year, competing in a sub-FIA F3 single-seater category) were assessed at McLaren's Technology Centre. The first two or three names, often the champions of the leading series, are usually selected rapidly.

Insight from those who have seen many

possible candidates competing, and other aspects like a driver's pre-2013 CV, also got thrown into the mix before the final list was agreed.

"You hope that anyone who is chosen has a chance of winning and people without experience of wings tend to struggle," says Titchmarsh.

"You also have to have people who have the opportunity to become established professional drivers. The Award has a pretty good record of people who have made careers as racing drivers."

Once contacted, the six 2013 finalists had three weeks to prepare, something that experienced judge Titchmarsh has seen improve over the years. "All the guys we saw this year prepared themselves, like talking to previous Award winners," he says.





Six drivers, three cars, two days: 2013 crop prepares for battle



Each finalist got his own F2 car and engineer

ALL PICS: EBREVILAT

Similarly, Porsche's Human Performance Centre tested the fitness of the finalists and sent the results on.

Although not the key factor in the final outcome, both the simulator and fitness tests give the judges an insight into how serious and well prepared the drivers are. It also gives potential areas of improvement that can be passed on to the finalists in the feedback sessions that take place after the AUTOSPORT Awards.

THE TRACK TESTS

The real meat of the Award is the two days spent at Silverstone. This year each finalist had his own Formula 2 car, plus runs in a DTM Mercedes C-class coupe and one of two McLaren MP4-12C GT3 machines.

After sighting laps in roadgoing McLaren MP4-12Cs (no small thing itself, especially given two of this year's finalists don't even have road licences!), all six head out for the first F2 run.

All three F2 outings on day one, which this year stayed dry, are conducted without the Williams-built JPH1B's overboost facility. That means the drivers 'only' had 425bhp, but seeing as they are all used to racing cars with less than 200bhp that's probably enough.

Getting all six on track at the same time eradicates many of the problems and guesswork that was the case when the Award only had two single-seaters.

"Having the six cars helps a lot, especially if you have poor weather," agrees Kirkaldy. "If you only had two cars and more than two people were in contention it makes it very tricky to compare.

"I think the process is fair and always has been. Every single year I've been a judge the right person has won it. I don't know of a more in-depth process for any motorsport award."

Part of that experience comes in the afternoon of day one, when all the finalists get a go in the McLaren and most have their DTM runs, too.

"Generally it's about the single-seaters, but having the other cars is good if it's close and you need to fall back on them," adds Kirkaldy. "And it's great for the drivers to try cars they wouldn't do otherwise."

The DTM runs are completed on the morning of day two, which dawns with a wet track, and then it's back into the F2 running. This time the drivers get overboosts – a maximum of two per lap – throwing another challenge at them as to how best to use the extra 75bhp.

After all the runs are complete, the engineers running the F2, McLaren and DTM cars give feedback to the judges and provide any data required. The amount of information available has increased dramatically in recent years and McLaren now sends Rosie Wilson, normally to be found working on Sergio Perez's strategy, to help.

"Rosie applies F1 analysis and processes all the lap times and statistics, which is useful to back up your instinct," says Williams. "We're driven by lap times and feel, but it's always good to have all that data to back it up."

INTERVIEWS

The final part of the decision-making process comes back at McLaren. The finalists are all interviewed and given a tour before the judges sit down to pick the winner.

Like the fitness and simulator tests, the interviews rarely decide the contest, but they do give an interesting insight. "You get a much better idea of the maturity level when you sit down and talk to them," says Kirkaldy.

This weekend, at the AUTOSPORT Awards in London's Grosvenor House, the result of all this will become known and the 25th McLaren AUTOSPORT BRDC Award winner crowned. 🏆

Kirkaldy, a judge in the early 2000s who returned to the panel this year, adds: "Drivers now take it seriously – they have to – because you have to be exceptional."

SIMULATION AND FITNESS

To reflect the increasing importance of simulators and driver fitness in motorsport, both aspects have become integral parts of the Award process.

All six drivers in 2013 spent time in Darren Turner's Base Performance Simulator, driving on both the Silverstone International circuit and a fantasy track. GT star and former Award winner Turner then put together a report on each driver's performance that was sent to the judges.

THE PRIZES

As well as joining a select group, this year's victor will receive £100,000, a McLaren F1 test drive, BRDC membership, and an Arai GP-6 RC carbon helmet.

"Winning the Award makes a massive difference to your career, bigger than the financial side," says 1997 winner Kirkaldy. "After winning, everyone knows who you are and what you've done."





JACK AITKEN 18
Formula Renault NEC runner-up

"There are things I wish I could go back and do differently, but I think everyone could say that. It's a huge challenge and enormous fun.

"The runs in the DTM car went really well. I felt really fast and got to grips with it really quickly. The driving style required is not that far off what you need for a single-seater so I felt comfortable.

"The conditions were difficult at the end day two – between wet and dry – and when it came to the final runs in the F2 car I didn't get the best out of the tyres. That was disappointing, because F2 is such a big part of the test.

"But that's just how it is; I'm not worried. I went into it with an open mind and got two days off school to drive some of the best cars around. It doesn't get much better than that! Obviously, I want to win, but if I don't that's fine too. I'll be back to win it next year!"



JAKE HUGHES 19
BRDC Formula 4 champion

"I was happy with how the two days went and have no regrets at all. When you're driving cars like that and you're not used to them you're going to come away with a little bit left on the table. I think everybody could say that.

"Different conditions on each day made it difficult, but I thought it best to just progress and learn rather than push straight away. It's that old cliché of 'don't run before you can walk'. I think that showed in my runs. Each lap was getting quicker and the best I felt was in the last qualifying session in the F2 car.

"I rang drivers I knew who had taken part in the Award to get some advice beforehand: Alex Lynn, Darren Turner, Joey Foster and Danny Watts. They told me what the judges are looking for, but the best advice was just to enjoy it – driving those cars for two days was a massive privilege."



CHRIS MIDDLEHURST 18
Formula Renault BARC champion

"I felt the two days went really well; it was a great experience to drive those cars and hopefully I showed what I can do.

"It was quite a learning curve getting used to the cars in such a short amount of time and trying to get to the limit straight away. I think I did the best I could with that and now we're just waiting until December 1st!

"I did two days in the simulator, which they provided, and did a couple of track days in a Nissan GT-R road car to get used to the weight of a GT car, but we don't really have the money to spend thousands preparing for the test.

"The F2 car went really well because I'm used to driving single-seaters. The McLaren and the DTM car were very tricky. I've driven cars with roofs but they were very different. Hopefully, I've proved that I can adapt."



SEB MORRIS 17

BRDC Formula 4 runner-up

"I stepped up my training to get fitter for driving quicker cars and tried to mentally prepare. I didn't find the cars too physical, and that meant I was able to focus on my lines and my driving rather than struggling to hang on.

"I would say the first session of the second day in the wet in the F2 car was my favourite by far. I found a really good line and extracted maximum grip from the car with as little wheelspin as possible by short-shifting through the gears to use maximum torque from the engine.

"I was worried about crashing the DTM car, because it's very expensive, and did five laps at exactly the same lap time on new tyres, so that was probably the toughest challenge.

"I felt I extracted the absolute maximum from the cars and made no big mistakes. I've done all I could so it's for the judges now."



MATT PARRY 19

Formula Renault NEC champion

"It's a massive pressure to be there and as a racing driver you're trying to be on the limit all the time without making mistakes. We all know with the Award that if you make a mistake it's all over and it's difficult to manage that.

"It was a fantastic event to be part of and I learned so much about what is expected of professional drivers, which will help me massively in the future.

"The only car I felt I could have found a bit more time in was the DTM. I listened too much to the instructions, which meant I didn't experiment enough.

"We had an MSA Academy day beforehand, where 2008 winner Alexander Sims gave a talk. He said you need to come away knowing you gave 100 per cent.

"I feel I've done that, but I'm not going to think about it too much because then it will be a massive disappointment if I don't win."



CHARLIE ROBERTSON 16

Third in BRDC Formula 4

"It was a massive opportunity for me to show what I can do and I feel I made the most of it. Hopefully that will be enough. There was a wide variety of cars, so I had to adapt my driving style in so many different ways – that was the biggest challenge.

"I went into it not expecting to set the world alight and just do the best I could. I think I did a good job. It helped me improve myself and I had to raise my game because the cars are a lot more technical than anything I'd driven before. I had to get my head around changing wing angles and rollbars while driving around, which was important to do to find those last few tenths.

"The best bit was the McLaren GT car, it suited me really well. I wouldn't say there's anything I would change about the two days. I felt I did the best I possibly could and I can't change it now!"

CHRISTMAS GIFT IDEAS

Chater's Motoring Booksellers

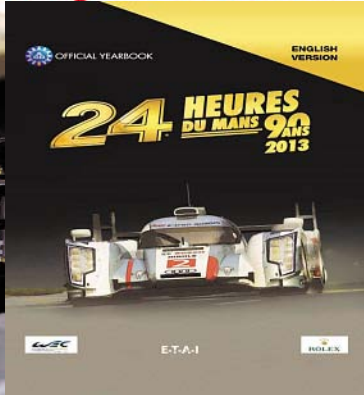
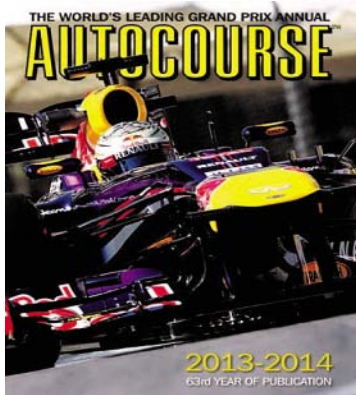

POST FREE £43.50 INLAND UK ONLY **POST FREE £45.00 INLAND UK ONLY**

Tel 01256 765443 Fax 01256 767992

Probably the Worlds LARGEST Selection of Motoring Books & DVD's

www.chaters.co.uk

It's narrow, it's twisty... Can you drive it flat out?

Try the challenge of Speed Hillclimbing at the
Gurston Down Hillclimb Drivers School

- No experience necessary • Qualified, MSA-licensed Instructors
- Helmets provided (if required) • Superb lunch and refreshments included
- Full day's activities just £165 • "Gurston grin" guaranteed!!
- Competition Licence upgrade option available (ask when booking)

Year's top student receives a free day at the Thruxton Motorsport Centre!

2014 dates: April 8th, May 6th, June 10th, July 8th

BOOK ONLINE NOW or

call Andrew Hext on 07971 989517

Supported by Car & Commercial Services

Member of the Association of Hillclimb and Sprint Schools

Gurston Down is scenically located 9 miles south west of Salisbury, Wilts.

Full details at www.gurstondown.org

GIFT
VOUCHERS
AVAILABLE



Are you a Headcase?

Never fear scrutineers

Whether you are in Professional Racing, Historic Racing, Track day, Rally or Go Karting, arrive with confidence with your valuable crash helmet protected.

Headcase Europe.com

Headcase Europe.com
2, Norreys Drive, Maidenhead, Berks, SL6 4BW
Telephone: 00 44 1628 671210
Mobile: 00 44 7774 236153
Email: pervez@headcaseurope.com
www.headcaseurope.com

Features

- ◆ Choice of colours, Black, Red, Blue and Green.
- ◆ Nylon carrying handle for strength and ease.
- ◆ Soft inner lining.
- ◆ Practical hard wearing zip for easy access.
- ◆ Storage space for spare visor.
- ◆ Order today and arrive knowing your crash helmet is safe to use.
- ◆ Price £29.99 + P/P £8.90 next day delivery.
- ◆ Order on line or by phone.

Suitable for all sizes of crash helmets. Enjoy your Headcase experience.



Ayrton Senna - The Final Picture
San Marino GP - 1st May 1994
Ayrton Senna de Silva,
born 21/09/1960, died 01/05/1994

AYRTON'S LAST RACE LIMITED EDITION GLASS ART PRINT

This incredible photo was taken on May 1st 1994 at the San Marino Grand Prix.

Nowhere recorded is there a photo graph taken at such close proximity, leaving the question- what must have been going through his mind on that fatal day?

A fabulous investment for any collector, the print is printed onto toughened glass to give an unrivalled finish and produced as a limited edition of 1000.

The overall size is 950mm x 550mm and comes ready to hang with a certificate of authenticity and plaque.

Tel Abi on 01625 427683 / 07900245459 Email: abi@f1.co.uk Or visit our website: www.f1.co.uk



CHRISTMAS GIFT IDEAS

A3 2014 Jakob Ebrey Motorsport Photography Calendar

Relive the thrilling 2013 season throughout all twelve months of 2014 with this fantastic A3-sized, full colour wall calendar featuring photographs from the team at Jakob Ebrey Photography, the official photographers for TOCA.

A fantastic gift for any motorsport fan!
10% of the sale price goes to the Henry Surtees Foundation.

Size: A3 Landscape (42cm W x 29.7cm H)
Binding: Wire Bound
Price: £15.00 plus £3 P&P
Website: www.jakobebrey.com



palmer SPORT

THE PERFECT
CHRISTMAS
GIFT!

THE WORLD'S BEST
DRIVING EVENT

GIFT VOUCHERS NOW
AVAILABLE FROM £498

01403 733999
WWW.PALMERSPORT.COM



Young Drive!

YOUR FIRST DRIVING LESSON...
AT A FAMOUS MOTOR
RACING CIRCUIT!
AGES FROM
11-17

GIFT VOUCHERS
AVAILABLE FOR **£79**
BRANDS HATCH - OULTON PARK
SNETTERTON - BEDFORD AUTODROME

TO BOOK CALL 0843 453 1000
OR VISIT WWW.YOUNGDRIVE.COM

THIS CHRISTMAS

FEEL THE RUSH

AT A WORLD FAMOUS
RACING CIRCUIT

DRIVING
EXPERIENCES
FROM
£99

Oulton Park
Brands Hatch

MSVDRIVINGGIFTS.COM

FERRARI V12 ENGINE COFFEE TABLE



£3500

Free delivery worldwide

enginecoffeetables.co.uk

Diecast race models

20% OFF USE ONLINE CODE
OFFER ENDS 31/12/2013
ONLY IN STOCK ITEMS APPLY **DEC13**



www.diecastracemodels.com

whybee

ONLINE DEPARTMENT STORE

ebay
amazon

MINI WRC TEAM
VODAFONE
MCLAREN
MERCEDES

Why buy from us?

- + SAME DAY DISPATCH
- + FREE UK DELIVERY
- + 100% POSITIVE FEEDBACK

OSRAM



LEGO



Are you ready
for Christmas?

stores.ebay.co.uk/WHYBEE-ONLINE-STORE

PayPal VISA MasterCard

GOOGLE SEARCH: WHYBEE ONLINE STORE



Great Motor Sport Christmas Gifts and rare
Racing items are all here



www.autos-uk.co.uk

WEB DIRECTORY

CAR BROKERAGE

RACING CARS FOR SALE
ALAN CORNOCK FCS
BUYING - SELLING - BROKERAGE
www.racingcarsforsale.co.uk
TEL: 01480 891212

DRIVER DEVELOPMENT

eugene **O'BR** *ien.co.uk*
DRIVER DEVELOPMENT
Tel: 0775 383 5629

ENGINES

JULIAN GODFREY
ENGINEERING
visit our new online shop www.racetuners.com

EXHAUSTS

Stainless Steel Exhaust Specialists
SIMPSON
Race Exhausts
Tel: 01753 532222 follow us on:
www.simpsonraceexhausts.com

eLITE racing transmissions
Rally & Race Gearboxes, GearKits, LSDs and Driveshafts
Tel: 01782 280136 Fax: 01782 269913
Email: sales@eliteracingtransmissions.com
www.eliteracingtransmissions.com

GEARBOXES

Gearboxman.com
COMPETITION TRANSMISSION SERVICES
Gearboxes & Axles for Road, Race, Rally and more
Telephone: 01582 840008 Fax: 01582 840007

MEMORABILIA

FINAL LAP
For Everything Formula One
www.finallap.net **WE BUY AND SELL**
+44 (0) 1245 287588 / 07771 920345

JMJ AUTOMOBILIA
America's #1 supplier of CART and FORMULA One Racing memorabilia. Large selection of signed original collectables. See our ad under marketplace Memorabilia. Call or For a mail listing at (609) 575 1143 or visit: www.JMJAUTO.com

HELMET GRAPHICS

Mike Fairholme Designs
Sole approved painter of Arai helmets.
Silver Birches, Corby Birkholme, Nr Grantham, Lincs NG33 4LE.
Tel: 01476 550630. Fax: 01476 550029.
email: fairholmedesigns@btconnect.com
www.fairholmedesigns.co.uk

MODELS

www.Diecast
race models.com
Specialists in 1:2 Scale Replica F1 Helmets

MOTORSPORT MEDICALS

Dr Mitchell
MSA, ACU and FIA medicals and ECG testing, also CAA pilot's and DVLA HGV medicals all available at weekends and at short notice.
For appointment call: 01 582 731 754
or E-mail: drmitch@nildram.co.uk
Situated near Luton, Beds, 45 minutes from London, close to M1 Junction 11

RACE PARTS

ARE DRY SUMP SYSTEMS
ARMSTRONG RACE ENGINEERING INC.
WWW.DRYSUMP.COM (916) 652-5282

RACE PRODUCTS

(JJC) race and rally
PASSIONATE ABOUT MOTORSPORT
www.jjcraceandrally.com

MARDI GRAS MOTORSPORT
www.mardigras.co.uk
HELIX
Performance Clutches
www.performanceclutch.co.uk

Pit to Car Autotel
Radio solutions **Digital Race Radio**
0044(0)1508 528837
www.raceradio.co.uk

RACE PRODUCTS

PIPER
www.pipercams.co.uk

PORSCHESHOP
www.porscheshop.co.uk 5% off with voucher code: **AUTOFIVE**
+44 (0)121 585 6088
adidas Arai PFC RED LINE SCHROTH

msar LONDON MOTORSPORT SHOWROOM
www.msar.co.uk

RACEWEAR

CROYDON RACE & RALLY CENTRE
www.croydonraceandrally.co.uk
220-222 Portland Road South Norwood London SE25 4QB
For Racewear & Motorsport equipment
FORECOURT PARKING Tel: 020 8656 7031

GPR sparco Arai uvex OMP
SCHROTH hans seat Arai BELL
RACEWEAR | KARTWEAR | SIMULATION
WWW.GPRDIRECT.COM

demon tweeks MOTORSPORT Direct
www.demon-tweeks.co.uk

WEB DIRECTORY

RACE CAR PREPARATION



MRR
Matt Roach Racing

Race Car Preparation Specialist

01268 207000 matt@mattroachracing.com
www.MattRoachRacing.com

RACEWEAR



AUTHORISED DISTRIBUTOR

OMP **YBRACING**
MOTORSPORT & PERFORMANCE

WWW.YBRACING.COM

THROTTLE & DRY SUMP SYSTEMS



atpower

www.atpower.co.uk
+44 (0)1953 857800

TRAILERS & TRANSPORTERS



PRG TRAILERS

www.prgtrailers.co.uk
Phone no: +44 (0) 1270 812402



BRIAN JAMES TRAILERS

»» Connected to you

www.brianjames.co.uk

WHEELS



Image® Manufacturers of bespoke split rim alloy wheels

www.imagewheels.co.uk
IMAGE WHEELS INTERNATIONAL LTD.

FOR SALE

3 x 1994 TYRRELL 022 F1 CARS + SPARES + ENGINE

CHASSIS 1: 3rd at Spanish GP – Blundell. 4.0 Judd (Yamaha) engine, paddle shift, traction control, ground up rebuild - **£150,000**

CHASSIS 3: Spa & Monza – Katayama. 4.0 Judd (Yamaha) engine, paddle shift, traction control, racing in BOSS GP - **£150,000**
All pit equipment needed to run the cars & a set of spare wheels is included.

CHASSIS 5: Jerez, Suzuka & Adelaide – Katayama. Roller / Show car - **£25,000**

Judd (Yamaha) GV3.5L V10 with zero miles – **£30,000**
Comprehensive spare packages also available (approx. 8,000 spares available including all major assemblies)

FOR ALL DETAILS & PHOTO'S PLEASE CALL
PHIL STRATFORD +1 949 310 4215



GINETTA G55 GT3



Full 2013 Spec - Large spares package included - Most cost effective GT3 car
For more info contact - tom.sharp@idluk.com - 07912 489796



Join Volkswagen Castrol Cup in 2014 season!



Fierce and well-balanced competition, great prizes and fantastic atmosphere – this is the Volkswagen Castrol Cup – an innovative racing series, which in 2014 will take place on tracks in Slovakia, Czech Republic, Germany, Hungary and Poland. If you want to be a part of competitive fight among the pack of international drivers in powerful, professionally prepared race cars join Volkswagen Castrol Cup in 2014 season!

This cup is amazing. The same cars and tyres means even chances for every driver – Tomasz Gollob, Speedway World Champion.



In the 2014 Volkswagen Castrol Cup will be held for the second season. Cup's organizer plans further increase of the attractiveness of competition. Thanks to the cooperation with Volkswagen Motorsport, Volkswagen Racing Poland team will prepare new versions of the GTI Golfs, with modified aero package and engine with extra power.

New philosophy of Cup's organization:

- race car and its transport to races during the whole racing season (14 races, 14 free practices, 7 qualifications)
- test day before and during the season
- full service maintenance during training and racing throughout the season
- fuel for training and racing
- high performance tires

- all track entry fees
- approved racing overall and a package of clothing with Cup branding
- advertising space on the car and on the racing overall
- 3 VIP tickets allowing to access the racing venues and the VW hospitality zone
- catering on every racing weekend (including training days)
- briefings and lectures, about driving techniques, using telemetry systems, and track safety, etc.
- marketing and media package
- valuable prizes: Volkswagen Golf VII and money prizes, with total amount of **116 000 €** to share

The whole package above is available for **43 000 €** (net price), regarding **5000 €** is paid in advance till 15 January 2014.

The main prize for the winner of the Cup is the new Volkswagen Golf as well as the amount of **30 000 €**. The runner-up receives **20 000 €**, and the third driver **10 000 €**. The money will be spend on further racing career development.

Drivers will also be rewarded after each race. The first eight drivers will receive the amount of **8 000 €** to share during each racing weekend.

Drivers will use race-prepared Golfs whose specification was developed in collaboration with Volkswagen R GmbH and Volkswagen Motorsport – Volkswagen departments dealing with sports cars. Car will be equipped with a 2.0 TSI petrol engine, which produces as much as 320 bhp (270 bhp + 50 extra bhp thanks to Push – to – Pass

system, whose activation for a short time spices up the competition). Cars are equipped with a sports suspension and other components adapting them to racing including a professional telemetry system.

More information on our website: www.volkswagencastrolcup.pl/en



Volkswagen Castrol Cup:
www.vwcastrolcup.pl/en
Volkswagen racing polska:
www.vwrcing.pl
Find us on Facebook:
[facebook.com/volkswagencastrolcup](https://www.facebook.com/volkswagencastrolcup)
Adam Gladysz, mob.: +48 602 495 549



Volkswagen Castrol Cup is really impressive series – great cars, fantastic prizes in affordable price – Andreas Mikkelsen, Volkswagen Motorsport rally driver.

RACE & RALLY CARS



Ford Focus Touring Car



Ford Focus S2000 car raced in the BTCC by Motorbase Performance in 2013, Car available without engine includes huge spares package. £25,000 + VAT
Contact Oly Collins or David Bartrum for more information on davidbartrum@motorbaseperformance.co.uk or 01732 822266

Porsche GT3R – 2013/14 spec



Porsche GT3R – 2013 Spec ready to race or test in GT
Used by Motorbase Performance in 2012, driven by Nick Tandy, Stephen Jelley & Steve Parish. Re-prepared to the highest standard regardless of cost. Not raced in 2013.
£220,000 + VAT – contact David Bartrum for more details davidbartrum@motorbaseperformance.co.uk or 01732 822266

JCW MINI CHALLENGE CAR FOR SALE

- Large spares package available at extra cost.
- Daf rigid truck also available.



Email: leeallen1@hotmail.co.uk
or Call 07802 496 988

RACE & RALLY CARS • TRAILERS & TRANSPORTERS

TRAILERS & TRANSPORTERS



Call Us Now! tel. 01327 263 384

www.woodfordtrailers.com sales@woodfordtrailers.com

RL 5000
£7,300 + vat



RL 6000
£9,500 + vat



Finest Built British Trailers.



PRG Trailers | Cheshire | UK | Tel: +44 (0) 1270812402
Web: www.prgtrailers.co.uk | Email: info@prgtrailers.co.uk

HOSPITALITY UNIT ••• FOR SALE •••



- Articulated Unit, currently white, with low mileage Renault Premium truck 16mtr total length.
- Commercial kitchen, central office, rear horseshoe lounge. Main 5 mtr awning and secondary 4 mtr.
- In built generator. Tables, chairs, flooring included.

Price **£37,750** ono.

For further details;
Email: studispires@hotmail.com
or call: **44 7768 256524**

BRIAN JAMES TRAILERS

» Connected to you



www.brianjames.co.uk

Discovery of Light

Driving efficiency and improving fuel consumption, the latest Race Transporter models feature advanced aluminium and lightweight composite construction.

With modern edge styling, and carefully designed interior space Race Transporter trailers demonstrate all the capability you require.

Race Transporter range from £ 7,099 (excl. VAT).



RACE TRANSPORTER

T +44 (0)1327 308 833

For more information and details of your local BJT dealer please call or visit our website.

MARKETPLACE

CAR TYRES

FOR ALL YOUR
AVON
 TYRES
MOTORSPORT
 RACING TYRES
 Inc. ACB 10 Formula Ford
 Contact

BMTR LTD

Tel: 0121 331 1122
 Fax: 0121 331 1144
 email: sales@bmtr.co.uk
 see our new website at www.bmtr.co.uk

MEMORABILIA

F1 COLLECTORS .COM



#1 FOR F1 MEMORABILIA & AUTOGRAPHS

We buy and sell F1 items
 AYRTON SENNA specialists
 Call CHRIS GRINT 01763 274448
 email: sales@f1collectors.com

JMJ Automobilia

SUPPLIERS OF RACE
 MEMORABILIA SINCE 1992

Florida, USA
(609) 575-1143

email: JM@JMJAUTO.COM
WWW.JMJAUTO.COM

NUMBER PLATES

FOR SALE

F1 DVR

F1 DRIVER

Historics Auction
 Sat Nov 30th.

CONTACT:
07715174444

RACE PRODUCTS

FREE **MSD**
 ONT 7/1/12

demon tweeks
 MOTORSPORT *Direct*

2014 CATALOGUE
 508 pages of the best motorsport parts, accessories
 and innovative new products. Available to order now.

TEL 0906 250 1516

Calls to 0906 numbers cost 50p per minute at all times. (Calls should last no longer than 11/2 minutes).

OR TEXT CODE MSAS TO 84010 WITH YOUR NAME, ADDRESS, POSTCODE. If you do not wish us to contact you by mail or text with any information, promotion or special offers we may have in the future, insert X at the end of your message. Brochure requests via SMS are charged at £1.50 per message sent. Calls to 0906 numbers cost 50p per minute at all times. (Calls should last no longer than 11/2 minutes).

www.demon-tweeks.co.uk

London Motorsport Showroom
www.msar.co.uk

msar UK agent for SCHROTH RACING
 ORDER HOTLINE: 020 8655 7877

RACE PRODUCTS

RACEWEAR

www.realsteel.co.uk

Denso mini race alternator. 12-16v adjustable. 50/30amp, 1 wire connection.

6425 6AL Digital Capacitive-discharge box. 530v to coil. 135mj spark for every firing!

POWERMASTER
 Performance
 (STARTERS & ALTERNATORS)

MSD

V8 ENGINES- parts and accessories
 REAL STEEL Unit 9, Tomo Industrial Estate,
 Packet Boat Lane, Cowley, Middx, UB8 2JP
 Tel: 01895 440505 Email: sales@realsteel.co.uk E&OE.

Grand Prix Racewear
 08435 070 858 | WWW.GPRDIRECT.COM

"WHEN ONLY THE BEST WILL DO GPR RECOMMEND SCHROTH®"

SCHROTH RACING HANS® DEVICES
 FROM JUST - £325+VAT

PROFESSIONAL PRODUCTS & SERVICES FOR THE PROFESSIONAL DRIVER

sparco **uvex** OMP Aral BELL SCHROTH hans seat

Elite Carbon Fibre Carbon fibre race car component manufacturer

Contact Dave Greenwood 07809390316
 Email - davecarbonelite@googlemail.com
 Website elitecarbonfibre.co.uk
 EliteCarbonFibre Ltd.
 Units 20-22 Norwich Road Ind. Est.
 Watton, Thetford, Norfolk IP25 6DR

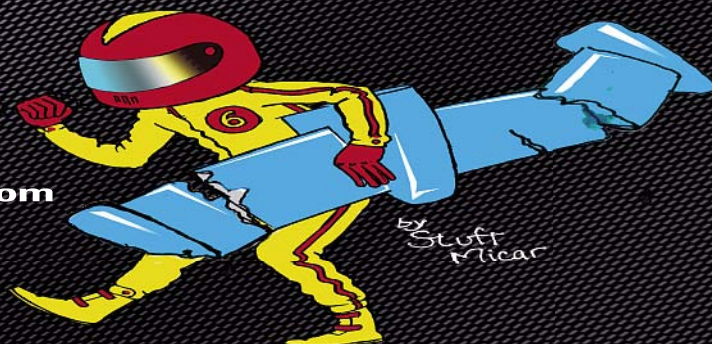

Carbon Composite Wings, Bodywork & Repairs

MOTORSPORT AUCTIONS

motorsportauctions.com

CLASSIFIED ADVERTS & AUCTIONS

THE GO TO WEBSITE
TO BUY & SELL
ALL THINGS
MOTORSPORT

Special Offer
Discount Code **MA101**

To celebrate the launch of motorsportauctions.com we invite you to list as many items as you like, and enjoy a 70% discount against our standard rates for every listing you make. This offer runs from November 12th 2013 until February 15th 2014.

Simply register on the site, enter your advert and include up to 20 photographs. As you go through the checkout process, enter discount code MA101 into the box on the checkout page and press the update button.



image © Harald Illmer

www.brc.at
BRR BAUMSCHLAGER
RALLYE & RACING

CLASSIFIED ADVERTS
STOREFRONTS
FEATURED VENDORS
DISPLAY ADVERTISING

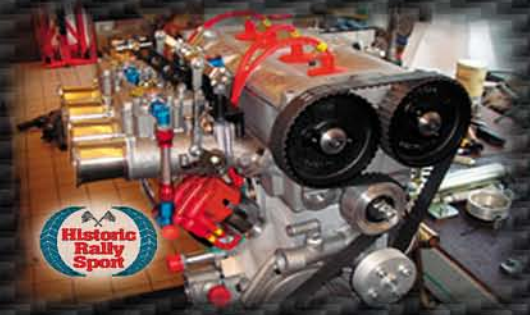

A GLOBAL SELLING PLATFORM

www.motorsportauctions.com



Revealed:
The history of
Formula One

Senna



Rindt



Prost



Villeneuve



Mansell



Fangio



Fittipaldi

Hawthorn

Piquet

Hill

Ascari



Clark

Hamilton

Button

Taruffi



FI Collectables • Team Memorabilia • Clothing

Buy • Sell • Evaluations

One of Europe's largest collections

+44 (0)1245 287588 • +44(0) 7771 920345 • sales@finallap.net

www.finallap.net



We have moved and are now fully open for business. We welcome you to our new premises, see website for details.

THE **FASTEST** WAY TO EXPERIENCE **KARTING**

KKC and Vital Motorsport are proud to offer you the chance to try out some of the fastest Arive & Drive Karts in the UK for all ages from 6 in Daventry, Northampton

Our different packages are designed for people looking to try before you buy as well as people looking for a one off experience

With Rotax Max 125cc 2-stroke race Karts, that provide 75% more horse power than your standard corporate Kart, and championship winning TonyKart race chassis, this is the pinnacle of Kart racing

Prices starting from just **£125!**

More information and prices online at www.kkckart.com/rotaxexperience



☎ 01327 844320 🌐 www.kkckartshop.co.uk

@martyn@kkckartshop.co.uk 🚲 5 miles from M1 junc.16/18

🌐 Whilton Mill, Whilton Locks, Daventry, Northants, NN11 2NH

AUTOSPORT

Want to advertise a motorsport job?

If you are recruiting in motorsport and wish to advertise with Autosport in print and online please contact Rachel.Brock@Haymarket.com by email or call 020 8267 5820.

For all current vacancies advertised please visit our website www.autosport.com



AERODYNAMICIST

To further strengthen the technical group and prepare for future chassis competition in the series, an Aerodynamicist is sought to join INDYCAR. Candidates must be suitably qualified and be highly motivated to work with an evolving series.

The candidate will be filling a new senior position and be expected to take an active role in the aerodynamic direction for the series. The position is full time and based in Indianapolis. Travel to race events and testing will be required.

To apply, please submit a resume to Human Resources at Jobs@Brickyard.com. Closing date for applications - 13th December 2013

Tim Samways
Sporting & Historic Car Engineers Ltd

A skilled and experienced engineer is required to work as a No 1 in a small but busy workshop. The work involves race preparation of historic race cars and classic road cars.

The applicant must be reliable, trustworthy and work to a very high standard, having the ability to lead others as a team and good customer relations skills. Need to be available to travel to race weekends during the season.

References and CV to barbara@timsamways.co.uk

MOTORSPORT JOBS



Mercedes-Benz has been setting the standard in racing for over 100 years. The MERCEDES AMG PETRONAS Formula One™ Team continues the proud history of the legendary Silver arrows with the clear ambition of winning the FIA Formula One™ world championships. Based in Brackley, UK, we are recruiting highly motivated, talented new members of our team. Please find further information about our current vacancies and our team in the 'join our team' area of our website www.mercedes-amg-f1.com

COMPOSITE CLEANROOM INSPECTOR

REF: CH763 - WEEKEND SHIFT

Reporting to the Cleanroom Manager you will be responsible for ensuring the integrity of each component manufactured is to MGP processes and procedures. Duties include ensuring drawings and manuals are available at the correct revision/issue level, ensuring all Engineering Change Notes (ECN's) are reviewed and any changes needed are carried out and producing check sheets for all components and all stages of component manufacture are inspected and signed off. You will also check all autoclave cures to ensure components are cured correctly and carry out visual checks to ensure components are correct to drawing and lay-up manuals.

The successful candidate will have a proven competence of composite laminating. You will be committed, motivated and self disciplined in your work and ideally have a working knowledge of SAP and Catia.

The successful candidate for the role must be committed, motivated and self disciplined and have a mindset of continuous improvement in their work. The candidate must be able to communicate effectively cross functionally. Flexibility in hours and approach is required, along with a 'can do', 'team playing' attitude. The ability to work under minimal supervision and in a professional manner is essential.

In return for your work and commitment, we offer a competitive package including bonus, life assurance, private medical cover, 25 days holiday, on-site gym and subsidised restaurant facilities together with the chance to work in a truly unique environment.

If you wish to apply for this position please forward your CV and letter of application with current remuneration details/salary expectations, quoting the job title/reference and where you saw the advertisement to recruitment@mercedes-amg-f1.com

CLOSING DATE: THURSDAY 12TH DECEMBER 2013

NO AGENCIES PLEASE



Sales Manager and Senior Sales Executive - Autosport International

We are looking for a Sales Manager and Senior Sales Executive to join Autosport International and the Performance Car Show. This represents a good opportunity to develop a career at Haymarket Exhibitions, and join one of Haymarket's flagship events, and Europe's largest and most influential motorsport exhibition.

Based in our offices at Teddington Studios in South West London, the job primarily involves selling stand space and developing new business through phone, face-to-face contact and network opportunities. The successful candidate will already possess established and proven sales experience, and have the ability to sell at all levels, from smaller companies to larger corporate clients. Previous experience in exhibitions is an advantage, although not essential, but being able to sell and communicate the benefits that exhibitions can deliver is vital. An interest in motorsport and cars is useful, as the successful candidates will have the opportunity to get immersed in motorsport and cars as attendance at related exhibitions, motorsport events and client meetings will be required.

Haymarket Exhibitions is one of the UK's largest consumer exhibitions companies with shows ranging from Autosport International to Clothes Show Live and is part of the Haymarket Group.

If you are interested in applying for this opportunity please visit the Careers section of our website www.haymarket.com or alternatively email your CV with a covering letter to:

recruitment@haymarket.com



WE ARE CURRENTLY LOOKING TO RECRUIT THE FOLLOWING POSITION AT RED BULL TECHNOLOGY:

HR25111301 PARTS SUPPLY HUB COORDINATOR

As part of our improvement plans within our dynamic Parts & Logistics Group we have a vacancy for a Parts Supply HUB Coordinator.

You will be responsible for coordinating parts at the factory along with the distribution of new and serviced parts to and from events. Accountability for coordinating parts supply to our customers and off car projects while meeting the requirements of our engine supplier are also important aspects of this role. You will additionally help coordinate and arrange bookings with third party Logistics agents and process customs invoices.

The ideal candidate will have a flexible attitude to working to rigid and sometimes unsocial deadlines. Proven Parts Control experience within a similar environment is essential for this role along with previous experience of an ERP system programme.

You will additionally enjoy working as part of a team in a high pressure, excellence orientated environment involving time sensitive situations. Commitment and a flexible approach to your work, together with exceptional organisation and communication skills are prerequisites for this role.

To apply for positions at Red Bull Racing and Red Bull Technology, please visit the jobs link on our website www.infiniti-redbullracing.com.

Closing Date for Applications – 12th December 2013.

PLEASE NOTE: No Agencies please.



And here are the views of some of our satisfied clients:

"We received an unexpectedly large amount of responses in only a few days. We would definitely consider Autosport for any future recruitment needs."

Jose Santos, Race Engineer Matech Concepts

"At Flybrid Systems we have used Autosport as a single source to advertise a range of jobs from design and development engineering roles to assembly technicians and administrators. We have always had a strong response and on the last occasion we received over 200 applications for 6 posts."

Jon Hilton FIMechE CEng, Managing Partner, Flybrid Systems LLP

"The decision to advertise for staff in Autosport was easy as the magazine is one of the most widely read motorsport publications in the world. The resulting response also met our expectations providing us with a large number of high quality candidates. What exceeded our expectations was the friendly and helpful nature of the Autosport staff who helped us with the timing and preparation of our advertisement. I would recommend the use of Autosport to any organization looking to recruit staff in our business."

Steve Hallam, Director of Competition, Michael Waltrip Racing

"Team WFR recognise Autosport magazine as one of the mainstream publications within the motorsport industry and therefore was an obvious choice when wishing to recruit new staff. We were thoroughly impressed with the extensive response to our advertisement and the quality of candidates that was received, just going to show that Autosport is read by high level motorsport professionals"

Jody Firth, Team WFR



HR131113081 – IT SUPPORT ENGINEER

We have an exciting opportunity for an IT specialist to join our IT team.

Your primary responsibilities will be focussed on Traxside and Factory support, working either at the track or based in Milton Keynes during the race weekends.

The ideal candidate will have proven experience of working with various technologies including HP Servers, NetApp storage, Cisco networking, VMWare, Microsoft Windows Server and a suite of business critical applications. Candidates will also have the necessary technical and people skills required to provide first to third level support in a pressurised and time critical environment.

The successful candidate must be self motivated, a team player and have excellent communications skills, along with the ability to think on their feet.

The position is based at Red Bull Technology's headquarters in Milton Keynes, however, there will be extensive travel required in this role.

HR131113031 – ASSISTANT SOFTWARE TEST ENGINEER

We currently have an opportunity for a Assistant Software Test Engineer, whose primary responsibilities will involve software testing of a wide range of applications developed within Red Bull Technology.

The main accountabilities for the role are:

- Execution of regression tests
- Drafting and updating of procedures and test cases
- Deployment of software applications trackside and monitoring these applications during events when required
- Support the handling of licences and routine software installations
- Setup of scenarios for investigations
- Support out of hours activities before and during events

The majority of the tasks listed above are currently related to off-car software (car configuration and setup, telemetry and pitwall applications), but a good understanding of race strategies and car performance issues are required to investigate problems and analyse results.

Candidates wishing to apply will be highly organised, with strong written and verbal communication skills. Applicants will be highly proficient at computer literacy, excellent at problem solving and be able to demonstrate the ability to write precise and accurate technical reports. Candidates must also be a self-motivator and display a flexible approach to work patterns, whilst enjoying the challenge of working effectively and to tight timescales.

This role is looking for a candidate with familiarity with Telemetry Systems and Matlab. Proven experience with the Motorsport or Automotive Industry and an understanding of Vehicle Dynamics concepts would be desirable, but is not essential.

For details of available opportunities at Red Bull Racing and Red Bull Technology, please visit the recruitment page on our website www.infiniti-redbullracing.com

Closing date for applications – 12th December 2013

PLEASE NOTE: No Agencies please.



International Motorsport Events ● Race Tickets ● Hospitality & Travel

SelectMotorRacing.com



Run by Fans for Fans

● Formula One ● Le Mans 24hr ● MotoGP ● Superbikes ● Historic



Pre-Book 2014 NOW

LE MANS 24 HOUR



- Tickets & Hospitality
- Circuit Camping
- Travel Packages**
- Coach Tours
- By Air options
- Self Drive Packages

HISTORIC TOURS

- Monaco Historic
- Mille Miglia
- Le Mans Classic
- Goodwood Festival of Speed
- Goodwood Revival
- 70th Anniversary D-Day Landings Tour

FORMULA ONE GRAND PRIX TRAVEL PACKAGES

OUR UK TRAVEL TEAM WILL LOOK AFTER YOU THROUGHOUT THE TOUR

Coach Tours

- Executive Coach Travel
- Free Excursions
- Circuit Transfers each day

Go By Air

- Choice of Hotels
- Airport meet and greet
- Return Hotel Transfers
- Free Excursions

RACE TICKETS

- Grandstands
- Circuit Hospitality
- Paddock Club
- Circuit Transfers
- Free find a flight service
- Flexible nights stay

FREE 2014 BROCHURE - OUT NOW!

Escorted Travel Packages to ALL F1 Events
2014 join us Austria | Russia



contact us on +44 (0) 1451 833 721 or email enquiry@selectmotorracing.com

www.selectmotorracing.com

CLUB AUTOSPORT

NATIONAL RACING • HISTORICS • RALLYCROSS • HILLCLIMB • TRACK TESTS



Jaguar E-types will not have to race Chevrons in 2014 Snett 3 Hours

BEN ANDERSON
NATIONAL EDITOR

ben.anderson@haymarket.com

@BenAndersonAuto



THE AUTOSPORT 3 HOURS IS

steeped in history, and we are happy to be associated with a fine historic racing event. I was lucky enough to take part in the 2010 edition, finishing fourth alongside Michael Schryver in his venerable Chevron B6. That grid was 35 strong, but support has slowly been on the wane. Only 23 cars qualified for this year's edition, compared to 39 in 2009...

Clashing repeatedly with the Monza Coppa Intereuropa – another big event in a crowded market – hasn't helped. Indeed, the only reason I was able to drive with Schryver in 2010 was because ace preparer Simon Hadfield was on duty for another client in Italy.

That should be sorted next year, thanks to tie-up with the GT and Sports Car Cup. Linking up with the Flavian and Vanessa Marcais initiative will not only bolster the grid by avoiding an unnecessary calendar clash, it will also bring the possibility of more exotic GT machinery joining in.

With that comes the move to 'ban' the sports-racers that have dominated the modern version of this event. It's no secret that you need a Chevron B8 or something similar to stand a chance of outright victory, meaning the smaller GT cars that make up the bulk of the entry (and are a truer representation of the roots of the original race) are relegated to a sideshow.

Siphoning off the sports-racers onto their own grid should also improve safety, reducing the sort of risky speed differentials that can cause real problems during lappery. If enough extra 'big banger' sportscars can be encouraged to join the secondary race, we could have an expanded 3 Hours meeting even more worthy of the name, and the history.

3 Hours revamp to boost grid

HSCC joins up with GTSCC to revitalise historic Snetterton enduro

THE AUTOSPORT 3 HOURS WILL be revamped next year to try to boost interest on the 50th anniversary of the last of the contemporary enduros.

The Historic Sports Car Club event, revived in 2007, has so far run to Guards Trophy rules, which allow pre-1969 small-capacity sports-racers. All seven historic 3 Hours have been won by Chevrons that were too new to have appeared in the original event, which last ran in 1964.

In a bid to boost entries, the HSCC is now making the event for pre-1966 GTs, and inviting racers from the GT and Sports Car Cup series as it targets doubling the grid to 50 cars.

HSCC director Grahame White believes joining forces with Flavian and Vanessa Marcais' GTSCC makes sense. "They have some nice cars so it could be something a bit different," said White, who revealed the 3 Hours would become a non-championship event. "The idea is that between us we can encourage more interest."

White also confirmed that large-capacity GTs, like Bizzarrinis

and Chevrolet Corvettes, would also be welcomed. "It means we can be a little more open with the cars we allow," he added. "If it works and we get support it would become a long-term thing."

Vanessa Marcais believes GTSCC racers will support the event. "Some of our competitors have been asking us for a longer race so the chance to visit Snetterton for the first time [on the 300 circuit, over the June 7-8 weekend], half a century after these cars raced there is particularly exciting," she said.

White added that it is likely the sports-racers, such as the Chevrons, will get their own two-driver enduro on the Snetterton programme, probably a one-hour race.

He also plans to allow larger-capacity sportscars to join the Guards Trophy sports-racers at events where they are separated from the regular Guards Trophy GT runners, such as the 3 Hours meeting. This has already happened at the Oulton Park Gold Cup and will be extended in 2014.

Other cornerstones of the HSCC's championship calendar, set to open at

PREVIOUS 3 HOURS WINNERS

1957	Ken Rudd (AC Ace)
1958	John Lowry (Lotus Elite)
1959	Jim Clark (Lotus Elite)
1960	Dickie Stoop (Porsche 356B)
1961	Mike Salmon (Jaguar D-type)
1962	Mike Parkes (Ferrari 250 GTD)
1963	Jim Clark (Lotus 23B)
1964	Jack Sears (AC Cobra)
2007	Simon Hadfield/Michael Schryver (Chevron B6)
2008	Simon Hadfield/Michael Schryver (Chevron B6)
2009	James and Jeremy Cottingham (Chevron B8)
2010	Gareth Burnett/Alex Ames (Chevron B8)
2011	Nick Fleming/Luke (Chevron B8)
2012	Nick Fleming (Chevron B8)
2013	Nick Fleming (Chevron B8)

Donington Park on April 6, are the Thruxton Easter Revival (April 19-20), Silverstone International Trophy (May 17-18), Cadwell Park (June 21-22), Brands Hatch Superprix (July 12-13), Croft Nostalgia Weekend (August 2-3), Oulton Park Gold Cup (August 23-25), Brands Indy (September 27-28) and Silverstone National (October 18).

BESPOKE
RACE SUITS



Grand Prix
Racewear

BESPOKE RACEWEAR SPECIALISTS
IN HOUSE DESIGN

08435 070 858 | WWW.GPRDIRECT.COM





Plant last raced in Carrera Cup in 2012 season

Dubai 24 Hours

FPA champ Plant to return in Dubai

EX-FORMULA PALMER AUDI champion and Carrera Cup GB race winner Richard Plant will return to action in January's Dubai 24 Hours.

The 2009 FPA title winner, who has not raced since his '12 Carrera campaign with Team Parker, will rejoin the team in a 997 GT3 Cup car. He joins the car's regular drivers – provisional British Endurance champs Ian Loggie and Chris Jones – and Parker engineer Julian Westwood.

"I'm chuffed to be out after a year

not doing anything," said Plant. "It's exciting and quite nerve-racking, but once I've knocked the rust off I should be right on it. My heart is still in racing and what a way to get back into it – in a 24-hour race with my old engineer [Westwood]."

Meanwhile, BEC frontrunner Javier Morcillo joins Ginetta company boss Lawrence Tomlinson, Mike Simpson and Paul White in a works G55.

"I am over the moon to be able to join Team LNT for such a big race,"

said Morcillo, who finished third in Britcar's flagship championship this season, alongside Mosler team-mate Manuel Cintrano.

"After working with Ginetta in Spain for five years and successfully running a G50 for so long, it feels great to race with the 'big-brother' team. Having Lawrence, Mike and Paul as my team-mates is a big responsibility, as they are all great champions. I am happy they are racing with me rather than against me."

Morcillo and White will split their driving duties between two cars, as they will also join British Touring Car Championship race winner Tom Onslow-Cole in a KPM Racing-prepared Volkswagen Golf. The two-litre turbodiesel car will also be driven by VW Cup champion Aaron Mason and series rival Josh Caygill.

Meanwhile, British GT pair Joe Osborne and Lee Mowle will reunite in GT4-class champion team Optimum Motorsport's Ginetta G50.

British Formula Ford

Richardson eyeing three cars for expanded FFord attack

BRITISH FORMULA FORD PODIUM finisher Andy Richardson wants his family-run team to expand to three cars for next season.

The ex-Ginetta racer switched to single-seaters for 2013, with Richardson Racing leasing and running a single Mygale M12-SJ. That car has now been purchased and the team has plans to run another two EcoBoosts alongside it.

Though Richardson is keen to return to the championship as a driver, he said it was not crucial for him to race in 2014.

"We are hoping to run three EcoBoost cars next year and we have four or five very interested drivers, so things are looking positive, although not necessarily for me as a driver," he said.

"My options are open and I would like



Richardson ran sole Mygale in '13

to come back to Formula Ford as a driver, but the team comes first and if there is no car for me, then so be it.

"We showed towards the end of the year our car could be phenomenally quick and our engineers had done a great job. The plan for next year is to get some quick drivers and aim for the title."

Formula Renault

Fortec expands to Renault ALPS and 1.6 NEC for 2014

FORTEC MOTORSPORT IS TO expand into the southern European Formula Renault ALPS series in 2014.

The British team will now run in all three of Renault's main FR2.0 series, alongside its existing Eurocup and North European Cup campaigns.

Team boss Richard Dutton explained that one of Fortec's two NEC teams will simply be transferred to ALPS.

"We don't really need to run eight cars in NEC [as Fortec did this year]," said Dutton, "so one of our four-car NEC teams will become our ALPS effort."

Fortec is also linking up with Estonian team Scuderia Nordica to compete in the Formula Renault 1.6 NEC series.

Nordica ran Martin Rump to the runner-up position in both the NEC series and the Swedish FR1.6 championship this season.

Dutton said: "It's intended as an Estonian academy and we will support it; we're looking for premises outside the UK at the moment."



Fortec will run in all 2.0 series

Comprehensive motorsport insurance products to keep you on track;

- 🔍 Worldwide On Track
- 🔍 Personal Accident
- 🔍 Storage and transit
- 🔍 Track day
- 🔍 Liability
- 🔍 Commercial

Please complete an online quote request form at – www.ryanmi.com

Email – info@ryanmi.com Tel – +44 (0)1799 524202

Ryan Motorsport Insurance Limited is an appointed representative (557405) of Independent Broking Solutions Limited who are authorised and regulated by the Financial Services Authority, registration number 312026

RYAN
MOTORSPORT INSURANCE

BRDC F4

Officials and misfortune 'cost' Cook BRDC F4 winter crown

JAKE COOK RECKONS OFFICIALS' decision-making and bad luck cost him the BRDC Formula 4 Winter Championship at Brands Hatch last weekend.

Cook held a shared lead of the points before the final quartet of races, but was caught out when Saturday morning's qualifying session was red-flagged with five minutes remaining and not restarted. He slipped to five points behind eventual champion Matthew Graham after finishing third in the opening two races.

A front-wing problem derailed his qualifying efforts on Sunday, and he then

spun in race three before being baulked by Will Palmer, who was several laps down after pitting for wet tyres, but not shown any blue flags. Cook eventually finished 15 points behind Graham after recording a pair of fourths on Sunday.

"It was a shame," said Cook of the incidents. "I got held up behind him [Palmer] because there were no blue flags. I went to see the clerk of the course about it and he said there weren't and that they missed it. But it was qualifying that cost us, it was strange – I think I'd have won the championship without it."

Graham, who finished fourth in the main series, praised his Douglas Motorsport team after winning the winter title. He now hopes to graduate to continental Europe.

"It was an amazing feeling," he said. "We've worked hard and the team has done an excellent job."

"There was a bit of pressure coming into the series, as I was touted as a favourite, but I've done what I came here to do and I'm very happy with myself."

"Hopefully we can use this as a springboard to Europe next season."



Cook shared points lead before Brands

EBREY

MSA

NEC champion and Award finalist Parry joins MSA Team UK squad

FORMULA RENAULT NORTHERN European Cup champion Matt Parry has been promoted to the Motor Sport Association's Team UK squad.

The McLaren AUTOSPORT BRDC Award finalist was previously a member of the MSA Academy and now joins the top tier of the talent development programme.

Parry will receive management advice, coaching and support from a network of trained staff on the development arm of British motorsport's governing body.

"This season has arguably been the most rewarding in terms of the opportunities that winning the NEC title has brought me, and the invitation to join Team UK is right up there with the best of

them," said Parry, "I am well aware of the prestige that comes with it."

MSA Performance Director Robert Reid added: "We've been working with Matt for a few years and have been really impressed with his approach and progress through the junior categories."



Parry has graduated from MSA Academy

Pro Mazda

F3 ace Derani targets IndyCar with Pelfrey Pro Mazda move

MACAU GRAND PRIX PODIUM

finisher Pipo Derani is to contest the Pro Mazda series in the US in 2014 as he eyes a long-term move to IndyCar.

The 20-year-old Brazilian starred in a

recent Indy Lights test with Sam Schmidt Motorsports and has secured a drive with Team Pelfrey, which ran Briton Jack Hawksworth to the Mazda title in 2012.

"I'm looking and designing my career for 20 years from now," said Derani, who has set a target of being on the Indy 500 grid in 2016. "Even if I had gone to GP2 or Formula Renault 3.5 it would have been difficult to get to Formula 1."

Pelfrey team manager Nigel Tuckey said: "We have very high expectations for Pipo as his experience and success in F3 against stiff competition should place him among the drivers to beat."



Derani was third at Macau GP

LAT

HUMBLE PYE

The voice of club racing



DTM, F2 and McLaren tests were part of evaluation days

Anticipation builds ahead of 25th Award winner decision

After a tremendously busy season, culminating in another Walter Hayes Trophy Formula Ford thriller, November has turned into an odd sort of month – for several reasons, but particularly because not being on this year's McLaren AUTOSPORT BRDC Award judging panel has left an unusual void in my sporting calendar.

I'm proud to be involved in the annual competition from the start, though. I'd been blown away by David Coulthard's talents on his maiden FF1600 test at an inevitably chilly Thruxton in the spring of 1989, and excitedly flagged up the revelation to the office. Editor Peter Foubister cleverly brokered a mechanism to assist his fellow Scot with McLaren's Ron Dennis, and created a lasting legacy to which the BRDC eagerly subscribed later.

Kart graduate Coulthard was a shoo-in and did not have to face the shoot-out that has decided the destiny of the prestigious prize in subsequent years. They served each other well and, as the inaugural beneficiary, we could not collectively have selected a better MABA ambassador than DC. On Sunday, he will be its senior statesman as the 25th winner is announced at the AUTOSPORT Awards.

Having been a judge for all but one early year – I can't recall why I skipped it, but I must have deployed elsewhere – did I miss the buzz of

two bitterly cold winter days at Silverstone? Yes. Did I miss the poignant observations and intra-panel banter as it pored over the results with engineers operating the cars? Unquestionably. And did I miss the commitment and psychology as the teenaged Class of 2013 fought like gladiators for a potentially career-changing accolade? Without doubt.

But there is one huge positive I am drawing from the big-picture scenario. When I'm sitting down in the Grosvenor House Hotel in three days' time, as the 'showbiz silence' and whirling spotlights hold the protagonists on tenterhooks for just a few more agonising seconds, I too will have absolutely no idea which syllable will follow the booming "winner is" line.

At that point, the life of our elated champion – Jack Aitken, Jake Hughes, Seb Morris, Chris Middlehurst, Matt Parry or Charlie Robertson – will become a PR blur, hopefully with endless opportunities. His disappointed rivals, meanwhile, will pick themselves up and use the leverage of having been in the final of an elite contest to continue with the plans they have already been laying for 2014.

Marcus Pye

"One huge positive of not being a MABA judge this year is having absolutely no idea who has won"

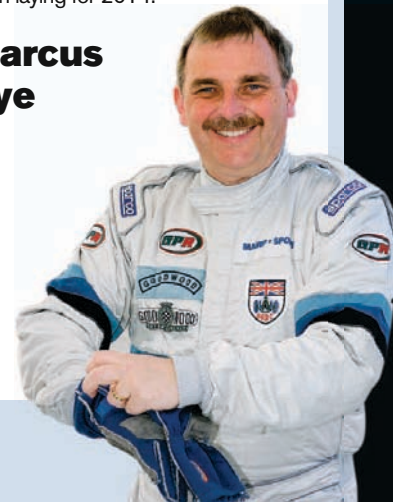

SUBSCRIBE TO AUTOSPORT AND GET...

ASTON MARTIN RACING POLO SHIRT



RRP
£39.95

+PLUS+

**FREE DIGITAL EDITION
SUBSCRIPTION &
UNLIMITED ACCESS
TO AUTOSPORT.COM**



www.astonmartinracingstore.com

FREE GIFTS

- ✓ Free Aston Martin Racing polo shirt. This polo shirt is black, with subtle team branding printed on the left chest.
- ✓ Free subscription to the AUTOSPORT Digital Edition and unlimited access to **AUTOSPORT.com**

SUBSCRIBE NOW!



- ✓ Save 19% on the cover price
- ✓ Pay just £36.99 every 13 issues by direct debit

Visit www.themagazineshop.com/autosport-m1013p

Or call and quote **M1013P**

08448 488 817

Please have your bank details ready. Offer ends December 5, 2013.

themagazineshop.com

THE BENEFITS OF SUBSCRIBING!

- ✓ Never miss an issue
- ✓ Free delivery direct to your door
- ✓ Unlimited access to news and views from the paddock
- ✓ Access to subscriber-only analysis and comment

Terms & Conditions: This offer is open to UK residents only. Overseas rates are available on +44 (0) 1795592 972. Please allow 35 days for delivery of your gift and first issue. The gift will be sent under separate cover from the magazine. Should we run out of gifts, you may be offered an alternative gift – there is no cash alternative. To activate your AUTOSPORT online account visit <https://secure.autosport.com/subs/activate.php> and enter your activation code (your personal magazine subscriber number which will be included in your welcome email/letter) along with your email address to access your extra AUTOSPORT content. Direct Debit rates are valid for one year after which they are subject to change – should prices change we will inform you in writing. We ask that you enter into a Direct Debit agreement with the intention that your subscription will continue for a minimum period of 12 months, even if the frequency of payment is for a shorter period, however, you will still have the right to cancel your Direct Debit in accordance with Direct Debit Guarantee. Should you wish to cancel your subscription it will be cancelled on expiry of the current term which will not be refundable, other than in exceptional circumstances. If a gift is included as part of the subscription offer we reserve the right to request the return of the gift. Details of the Direct Debit Guarantee are available on request. Savings are based on the standard UK cover price of £3.50. **Offer ends December 5, 2013.** Haymarket Media Group Ltd uses a best-practice layered Privacy Policy to provide you with details about how we would like to use your personal information. To read the full privacy policy please visit our website www.haymarket.com/privacy or call us on 08448 482 800. Please ask if you have any questions as submitting your personal information indicates your consent, for the time being, that we and our partners may contact you about products and services that will be of interest to you via post, phone, e-mail and SMS. You can opt out at ANY time by emailing the datacontroller@haymarket.com or by calling 08448 482 800.



F3 Cup organisers are targeting 20-car grids

EBREY/LAT

F3 Cup

Middlehurst weighing up F3 Cup for 2014

FORMULA RENAULT BARC

champion Chris Middlehurst is eyeing a move into the F3 Cup next year if his planned graduation to Formula Renault NEC fails to come off.

The 19-year-old earned a place in the McLaren AUTOSPORT BRDC Award shootout after taking the FR BARC title in his second season in the category this year. He hopes to graduate to FR NEC, but says it will be difficult unless he earns

the £100,000 prize provided by the Award – the winner of which will be announced in London on Sunday night.

If the move doesn't come off, he will look to move into the club-level F3 Cup series with a view to graduating to European F3 Open in 2015.

"It's £250,000 to do NEC and that will be tricky without the £100,000," said Middlehurst, who would buy his own car and then run with a team in F3.

"F3 Cup is club racing, but it's stepping up a bit [in terms of the car] and I don't want to give up on single-seaters. It's not as competitive as I'd like, but they [the organisers] are talking about 20-car grids next year and I'd go in aiming to win it.

"I'd rather be a big fish in a small pond than a small fish in a big pond, and I'd rather win F3 Cup than finish second or third in NEC because no one remembers [unless you win]."

2014 Calendars

BRDC F4, FR BARC get prime support slots on 2014 calendars

BRDC FORMULA 4 AND FORMULA Renault BARC will make one-off appearances supporting the Blancpain GT Sprint Series and British Touring Car Championship respectively next season.

Having joined the DTM at Brands Hatch in 2013, BRDC F4 will now support top-line international GT racing's return to the Kent circuit on May 17-18.

It will also support the Snetterton (June 21-22) and Brands Hatch (August 30-31) British Formula 3/GT rounds.

F4 CALENDAR*

DATE	CIRCUIT
April 26-27	Silverstone GP
May 17-18	Brands Hatch GP
June 21-22	Snetterton 300
July 18-19	Oulton Park
August 16-17	Silverstone GP
August 30-31	Brands Hatch GP
September 20-21	Donington Park
October 25-26	Snetterton 300



The six-event FR BARC season ends at Silverstone on September 27-28, the penultimate round of the BTCC.

FR BARC**

DATE	CIRCUIT
April 5-6*	Rockingham
May 31/June 1*	Donington Park National
July 26-27	Brands Hatch Indy
August 30-31	Snetterton 300
September 20-21	Croft
September 27-28	Silverstone National

*Triple-headers

**Double-headers unless specified

Sunoco Challenge

Smith rapid on Daytona debut

BRADLEY SMITH WAS QUICKEST

of the older-specification Prototypes in Daytona 24 Hours testing last week, as he prepares for his Sunoco Challenge prize race in January.

The Radical SR3 champion finished the official United SportsCar test third overall for the Action Express team, completing more than 100 laps and lapping faster than Christian Fittipaldi's benchmark time.

"Everyone is making sure I have as much time as possible to prepare for the race, so I was able to get a lot of laps in, which was great," said Smith. "There was a lot to learn but the team did a fantastic job of helping me understand the car."



Radical champ Smith was quick in Daytona test

Clio conversion video

Renault Clio Cup Series organisers have released a step-by-step video to guide prospective racing drives through converting road-going models into racers. Created in conjunction with Monster Sport Europe, the video – available on YouTube – details how to fit the official kit to convert a Clio Renaultsport 197.

Bailey wants boss role

Ginetta GT5 Challenge race winner Brad Bailey has put his driving career on hold as he explores a potential future as a team boss. The 19-year-old wants to focus on the development of his family-run Brad Bailey Racing team, and intends to run a driver in the Challenge next season. "I have run my own car for the past two years and have enjoyed engineering and setting it up as much as I have driving it," he said.

Chadwick in G55 test

Ex-Ginetta Junior racer Ollie Chadwick had his first outing in a G55 at Donington Park last week. Chadwick (below) won twice in Ginetta Junior this year and the BTCC-supporting GT Supercup is one of his options for 2014. He is also looking at Renault Clios, having made his Clio Cup Series debut at Rockingham earlier this month.



WALKER



Sardarov enjoyed a superb debut in Barwell Z4

HAWKINS

Britcar

Russian racer's stunning debut

TIMUR SARDAROV MADE HIS motor racing debut in memorable fashion at Brands Hatch last weekend, winning four Winter Warmer races with Barwell Motorsport's BMW Z4.

The 31-year-old has not taken part in any events since he used to rally when he was 18 years old. He qualified on pole by more than half a second and dominated

the seven-car field on each occasion.

"I've been too busy working [to compete]," he said. "My friend Leo Machitski suggested that I should go racing with him, so I came here today to get some signatures on my licence."

Sardarov will share the car with Machitski and Jonny Cocker for Barwell in next year's European Le Mans Series.



2013 BRDC Formula 4 Winter Series Champions
Matthew Graham & Douglas Motorsport

To join a winning team in 2014 contact Wayne - 00 44 7827 647 337



Rockingham

GIVE YOURSELF
THE COMPETITIVE EDGE
WITH THE NEW IMPROVED FISW STEERING WHEEL

Built in the UK by **St Cross**

Features include

- Meets FIA Standards On Design
- Bright LED Display • Delta Lap Times
- CAN or RS232 Interface • Race Timer

Ability to control ECU and GCU features such as

- Traction Control • Pit Lane Limiter • Paddleshift
- Radio • Launch Control • Extra Revs



Call: **+44 23 8022 7636**

email: sales@st-cross-electronics.co.uk

Unit 14 Mount Pleasant Industrial Park, Southampton, SO14 0SP, England

www.motorsportcables.com



St. Cross Electronics

Established 30 Years 1983 - 2013





Race three win helped Graham on his way to inaugural winter title

MSVR BRANDS HATCH, NOVEMBER 23-24

Graham wins and seals F4 title

VICTORY AT BRANDS HATCH HELPED Matthew Graham tie up the BRDC Formula 4 Winter Championship.

Having won twice in the first quartet of races at Snetterton, Graham held a narrow edge over F4 newcomer Jake Cook heading into the final four races last weekend.

"It was very challenging, coming here with just a small lead," said Graham. "I knew it would go down to the last race."

Poleman Will Palmer led all of race one, while Pietro Fittipaldi spun at Druids. Graham duly nipped into second and, despite constant attention from Cook, held on gamely while chasing the youngest son of the MotorSport Vision boss.

Sennan Fielding dominated race two from pole, with single-seater returnee Kieran Vernon, Cook and Graham slotting in behind. He edged away from them until he took the chequered flag almost 3.5 seconds clear of the trio, which also had Fittipaldi in close attendance.

Graham drove with impressive maturity as he led throughout a

damp race three. Fittipaldi, Fielding and Vernon formed a tight bunch close behind, chased by Cook.

Cook moved up to second place but fell back to fourth with a neat 360-degree spin that allowed Vernon and Fittipaldi onto the podium.

Vernon led the final race all the way to clinch victory on his debut weekend in the category, despite constant pressure from Fittipaldi and a late charge from Fielding, who finished a close third. Graham took the title with a solid sixth place.

Thirteen cars started the 90-minute Britcar night race on Saturday. Tom Howard took the early lead from polesitter Mark Radcliffe and Michael Symons, all in BMW M3s. Symons and Radcliffe argued over second until Radcliffe got back in front, taking Howard for the lead just before quarter-distance.

Radcliffe handed over to Adam Hayes, who pulled away from Symons to take the victory with his opponent a distant second, ahead of Mike Moss, in for Howard. Richard Bennett (Porsche) passed Miguel Faisca/Lee

Cunningham's Nissan 370Z for fifth late on. Mike Wilds retired the Paul Moraviec Porsche Boxster with fuel pressure problems, but still took the Production crown in the BMW E36 he shared with son Anthony and Ian Lawson.

In the Open Sports event Pascal Green won a close first battle of the Caterhams after the lead swapped several times between Mark Coleing and Ian Thompson. Battle resumed in race two with the same result, Simon Smith taking a distant third.

Smith started Sunday's first race

with dry tyres for a drying track and systematically picked off his wet-shod Caterham rivals to take his first win, comfortably clear of Timur Sardarov, who had started from the pits in a BMW Z4. The impressive Russian raced from last to first in race four and also won three weak Britcar Winter Warmer races.

Dave Charlton, for many years a tailender with a VW Beetle, switched to a SEAT Leon to win both Saloon races. Glen Rossiter and Nathan Dew twice chased him home.

● Kerry Dunlop & Linda Keen

BRDC FORMULA 4 WINTER CHAMPIONSHIP (25 LAPS)

1 Will Palmer; 2 Matthew Graham +1.537s; 3 Jake Cook; 4 Sennan Fielding; 5 Kieran Vernon; 6 Pietro Fittipaldi. **Fastest lap** Fielding 45.555s (95.45mph).

RACE 2 (25 LAPS) 1 Fielding; 2 Vernon +3.467s; 3 Cook;

4 Graham; 5 Fittipaldi; 6 Palmer. **FL** Fielding 45.585s (95.39mph).

RACE 3 (24 LAPS) 1 Graham; 2 Vernon +4.219s; 3 Fittipaldi; 4 Cook; 5 Fielding; 6 Falco Wauer.

FL Fielding 45.885s (94.77mph).

RACE 4 (25 LAPS) 1 Vernon; 2 Fittipaldi +0.954s; 3 Fielding; 4 Cook;

5 Palmer; 6 Graham. **FL** Fielding 45.709s (95.13mph).

POINTS 1 Graham, 166; 2 Cook, 152; 3 Fielding, 147;

4 Wauer, 133; 5 Palmer, 131; 6 Fittipaldi, 127.

BRITCAR NIGHT RACE (99 LAPS) 1 Adam Hayes/Mark Radcliffe (BMW M3); 2 Michael Symons (BMW M3)

+29.870s; 3 Tom Howard/Mike Moss (BMW M3);

4 Stanislav Aksenov/Florian Strauss (Nissan 370Z GT4);

5 Richard Bennett (Porsche 993); 6 Miguel Faisca/Lee Cunningham (Nissan 370Z GT4).

Class winners Howard/Moss; Aksenov/Strauss, Bennett; Chris Knox/Danny Russell (Mini Cooper). **FL** Symons 50.877s (85.47mph).

MSVR OPEN SPORTS, SPORTS RACING & GT RACE (21 LAPS) 1 Pascal Green (Caterham CSR); 2 Mark Coleing (Caterham CSR) +0.524s; 3 Ian Thompson (Caterham CSR);

4 Anthony Bennett (Caterham R300); 5 Simon Smith (Caterham CSR); 6 Richard Green (Caterham R400). **FL** P Green 50.193s (86.63mph).

RACE 2 (23 LAPS) 1 P Green; 2 Coleing +0.605s; 3 Smith;

4 R Green; 5 Peter French (Caterham R400); 6 Piers Hickin (Caterham Tracksport). **FL** P Green 50.400s (86.28mph).

RACE 3 (22 LAPS) 1 Smith; 2 Timur Sardarov (BMW Z4) +4.687s; 3 P Green; 4 Coleing;

5 Bennett; 6 Barney Pryor (Caterham R400).



Coleing chases Green in tight Caterham fight

FL Sardarov 51.754s (84.02mph).

RACE 4 (24 LAPS) 1 Sardarov; 2 Smith +18.721s; 3 P Green; 4 Coleing;

5 Pryor; 6 Bennett. **FL** Sardarov 48.219s (90.18mph).

BRITCAR WINTER WARMER (29 LAPS) 1 Timur Sardarov (BMW Z4); 2 Iain Dockerill (Porsche 997) +5.962s; 3 Neil Huggins (Marcos);

4 Steve Lansley (Marcos); 5 Peter Parsons (Ferrari 430); no other finishers. **FL** Sardarov 47.625s (91.30mph).

RACE 2 (29 LAPS) 1 Sardarov; 2 Huggins +32.846s; 3 Dockerill; 4 Parsons; 5 Lansley;

no other finishers. **FL** Sardarov 47.570s (91.41mph).

RACE 3 (30 LAPS) 1 Sardarov; 2 Dockerill +19.940s;

no other finishers. **FL** Sardarov 47.527s (91.49mph).

WEST KINGSDOWN TROPHY SALOONS (14 LAPS)

1 Dave Charlton (SEAT Leon Cupra); 2 Glen Rossiter (Renault Clio) +0.661s; 3 Nathan Dew (Honda Integra);

4 Graham Richardson (Vauxhall Nova); 5 John Deveraux (BMW E36 M3);

6 Rod Birley (Ford Fiesta). **CW** Rossiter; Birley. **FL** Rossiter 55.423s (78.46mph).

RACE 2 (14 LAPS) 1 Charlton; 2 Rossiter +1.875s; 3 Dew;

4 Mike Chittenden (BMW E36 M3); 5 Peter Osborne (Renault Clio);

6 Jon Wild (Rover Metro). **CW** Rossiter; Wild. **FL** Charlton 55.364s (78.54mph).



Hayes/Radcliffe M3 won the Britcar night encounter

The Class 2 Porsche of Loggie/Jones is provisional champ



2013 BRITISH ENDURANCE CHAMPIONSHIP REVIEW

The race is not quite over

It was a close fight for the last British Endurance crown between cars in different classes, but a protest means Ian Loggie/Chris Jones are yet to be confirmed champions. By **STEVE WOOD**

WALKER

84

It was clear from midway through the British Endurance Championship season that the overall title would be thrashed out between the Class 2 Team Parker Porsche 997 of Ian Loggie and Chris Jones, and the Paul Bailey/Andy Schulz pairing in the Horsepower Racing Aston Martin Vantage run by Scuderia Vittoria. Loggie and Jones took the title by just one point, but a protest by Bailey, based on an interpretation of the scoring system, means that the title will be settled by MSA judicial proceedings.

Loggie made no secret of his ambitions pre-season. "We're in this to win it," was his confident prediction in the late-February chill of a successful test session. He and co-driver Jones made it a clean sweep of class wins, although they did not always bag the single point for fastest lap in class, despite Loggie's sometimes exuberant style. "I got a call from the wall to slow down" was a frequent post-race comment from the Scot. Fuel and tyre conservation

were key in the three-hour races, and Team Parker often got away with just one mid-race stop.

Bailey and Schulz's season was totally different. A whole winter of preparation and upgrades to their Ferrari 430 went out of the window on the eve of the opening round, when the car lunched its engine in Friday testing. The pair is well-connected though, and by midnight the Scuderia Vittoria engineers were poring over a V12 Vantage delivered direct to Donington Park by AMR.

Spaniards Manuel Cintrano and Javier Morcillo, driving the Neil Garner-run Mosler, won that opening round and were to prove the nemesis to the Aston pair through the season. While Schulz had a slight edge over Bailey, the difference in pace between pro driver Morcillo and his eye surgeon colleague in the Mosler was marked, and Morcillo used all his skill and courage to build a buffer for Cintrano's middle or final stints. While the Aston had just one DNF along the way, when a suspension component failed at Brands Hatch, the Mosler endured waterlogged electrics during a Silverstone deluge and failed to start at Rockingham due to a blown engine in qualifying.

Electronic issues also plagued Mike Millard's ageing Rapier SR2 prototype, the only other regular Class 1 contender, squandering a talented line-up of co-drivers that included Nigel Greensall, Adam Sharpe and Karsten le Blanc.

Invitation entries twice showed the way: the July round on the Brands

Hatch GP circuit attracted a raft of British GT regulars ahead of their own series' race there, and Tom Onslow-Cole's Aston Martin was dominant until Lawrence Tomlinson and Mike Simpson nailed it on fuel economy in the works Ginetta G55.

The Silverstone 1000km, replacing the blue riband 24 Hours and a points-scoring round this year, featured Mark Poole and Richard Abra making it back-to-back wins in Britcar's flagship, this time in the Barwell-run MP Motorsport Aston.

Behind Loggie and Jones in Class 2, the Tracktorque Chevron GR8 of Tommy Field and Chris Hart occasionally cut fastest lap, but suffered with early-season engine woes. BPM gradually got to grips with its Renault Megane Trophy car, regular Ash Woodman's season coming alive once reigning champion Martin Byford helped to develop both car and driver, replacing early-season cohorts Jeff Smith and Simon Leith.

In truth only Simpson Motorsport's Anthony Mott and

Peter Cook were able to take the fight to the class leaders. Starting the season in a Porsche 997, they switched to an Audi R8 at Brands Hatch, where they were subsequently stripped of their class win due to a discrepancy with the car's technical passport with regard to the championship's power-to-weight regulations.

The Webb brothers, Tom and James, in the GTS Motorsport BMW GTR, had sewn up the Class 3 title by Brands Hatch, helped by a stunning second overall at a rain-soaked Silverstone, and weren't seen again. The class petered out after the 1000km, but was kept alive in the early races by the brio of veterans Anthony Reid and Ray Grimes in the works Chevron GT4, with the assertive Reid often punching above his weight.

Small grids and a cancelled round led to this being the final season for the British Endurance Championship, with Britcar going back to basics for next season. ❧

CHAMPIONSHIP STANDINGS

POS	DRIVERS (CAR)	POINTS
1	IAN LOGGIE/CHRIS JONES (Porsche 997 GT3 Cup)	185
2	PAUL BAILEY/ANDY SCHULZ (Aston Martin V12 Vantage GT3)	184
3	JAVIER MORCILLO/MANUEL CINTRANO (Mosler MT900R)	138
4	A WOODMAN/J SMITH/S LEITH/M BYFORD (Renault Megane V6 Trophy)	119
5	TOM WEBB/JAMES WEBB (BMW M3 GTR)	94
6	M MILLARD/K LE BLANC/N GREENSALL/A SHARPE (Rapier SR2)	85



WALKER

2013 BRITISH RALLYCROSS REVIEW

Godfrey glory run goes on

The reigning double champion was odds-on to make it three in a row in 2013 and he didn't disappoint. **HAL RIDGE** looks back at another fine year for the ace engine builder and driver

Reigning British Rallycross champion Julian Godfrey entered the season as favourite to make it three titles in a row, and the Sussex-based engine builder delivered.

But Kevin Procter scored victory in the season opener at Lydden in March, with Godfrey second and Pat Doran third. Procter led again in

round two at Mallory Park but suffered engine failure, allowing Mark Watson to claim his first British championship victory, ahead of Steve Harris and Icelandic driver Jon B Hrolfsson's low-budget Subaru Impreza. Godfrey retired on the first lap with accident damage but still collected the two bonus points available for being fastest in

practice and the heats.

The championship headed north to Knockhill for round three, where Andy Scott made his first appearance of the season and took victory ahead of Godfrey, who was content to extend his points lead with second place. Doran completed the podium.

The series returned to Mallory for round four, where Godfrey finally took his first victory of the season. Doran's Citroen DS3 was Godfrey's only real challenger and finished second, ahead of Devonian Andy Grant (Ford Focus), who made his first visit to the podium of the year.

Godfrey then claimed maximum points in round five in Belgium, ahead of Doran and Procter, before returning to his style of consistently collecting points without pushing too hard at Lydden. He finished second in Kent, behind European star Liam Doran, who made a one-off appearance in his DS3. Doran Sr again finished behind

Godfrey to all but concede the title.

Welsh circuit Pembrey hosted the penultimate round, and it was as good as a lap of honour for Godfrey, the Ford Fiesta driver claiming the title despite spinning out of the lead at the final corner to hand Pat Doran his first victory of the season. Godfrey recovered to finish second.

Croft hosted the season finale, which included the British Rallycross Grand Prix the following day. Andy Scott won the final round, flanked by GP winner Procter and Scott's son Marc, making his Supercar debut. Godfrey finished fourth. ❧



Godfrey's Ford Fiesta was already champion when BRC visited Croft

CHAMPIONSHIP STANDINGS

POS	DRIVERS (CAR)	POINTS
1	JULIAN GODFREY (Ford Fiesta)	129
2	PAT DORAN (Citroen DS3)	101
3	ANDY GRANT (Ford Focus)	80
4	MARK WATSON (Citroen Xsara)	79
5	JON B HROLFSSON (Subaru Impreza)	76
6	STEVE HARRIS (Ford Focus)	73

2013 BRITISH HILLCLIMB CHAMPIONSHIP REVIEW

Moran restores status quo

The triple champ missed out on a fourth crown last season, but put that right in 2013 by becoming the most successful hillclimber in history in his family's trusty old Gould. By **EDDIE WALDER**

After losing out in 2012, it was back to normal service for Scott Moran, who clinched his fourth British title with an event in hand.

The tale is clearly told by his 17 run-off victories and three hill records, whereas runner-up (and last year's champion) Trevor Willis took seven wins and broke two records.

In addition, Moran became the most successful hillclimb competitor of all time, passing the Martin Groves 104-wins mark to reach 112 by the end of the season. Moran is still only 37 and, despite his Gould having run for nine seasons, no other car is consistently as successful. It is feasible that he could continue winning for many more seasons, unless somebody else can match his consistency, and he has vowed to continue for as long as he has a championship to defend.

With a new and more compact OMS chassis, Willis doggedly took

the fight to Moran, but he had more competition this year. Scottish driver Wallace Menzies took a total of four victories and became a hill record breaker, but lacked the consistency to finish better than third overall.

The big surprise came from 22-year-old Alex Summers, who took fourth overall and displaced Roger Moran to fifth. Although it was his first time outside the top four since 1997, the elder Moran did at least take one run-off victory.

Summers won three rounds, including two in one day at Doune, lifted the class-based Hillclimb Leaders title, and nearly took the Midland crown, which is the largest regional competition. Summers is clearly a future British champion, but will need more power and possibly a different car to achieve this.

Will Hall and John Bradburn placed sixth and seventh respectively, their best positions to date.

Jos Goodyear was less successful



Moran Jr returned to the top of the hills in 2013

than last year with only one win – albeit with a hill record – having suffered with early-season electrical problems.

The last two seeded places went to Tom New, who started the season late, and the veteran Deryk Young, who returned to a seeded place for the first time since 2010. ❧

CHAMPIONSHIP STANDINGS

POS	DRIVERS (CAR)	POINTS
1	SCOTT MORAN (Gould-NME GR61X)	258
2	TREVOR WILLIS (OMS-Powertec 28)	246
3	WALLACE MENZIES (DJ-Cassie Firestorm)	204
4	ALEX SUMMERS (DJ-Suzuki Firehawk)	177
5	ROGER MORAN (Gould-NME GR61X)	170
6	WILL HALL (Force-Nissan WH)	128

Teddington Studios, Broom Road, Teddington, Middlesex TW11 9BE, UK.
Tel: +44 (0) 20 8267 5804 Fax: +44 (0) 20 8267 5922
E-mail: mail@autosport.com Website: www.autosport.com

EDITOR-IN-CHIEF
Andrew van de Burgt
andrew.vandeburgt@haymarket.com ext.5974

EDITOR
Charles Bradley
charles.bradley@haymarket.com ext.5889

GROUP F1 EDITOR
Jonathan Noble ext.5810
jonathan.noble@haymarket.com

F1 EDITOR
Edd Straw ext.5887
edd.straw@haymarket.com

FEATURES EDITOR
Kevin Turner ext.5432
kevin.turner@haymarket.com

NEWS EDITOR
Glenn Freeman ext.5309
glenn.freeman@haymarket.com

REPORTS EDITOR
Jamie O'Leary ext.5811
jamie.oleary@haymarket.com

MANAGING EDITOR
Peter Hodges ext.5903
peter.hodges@haymarket.com

RALLIES EDITOR
David Evans
david.evans@haymarket.com

DEPUTY NEWS EDITOR
Sam Tremayne ext.5952
sam.tremayne@haymarket.com

ART EDITOR
Lynsey Row ext.5914
lynsey.row@haymarket.com

PRESENTER/SUB-EDITOR
Henry Hope-Frost ext.5835
henry.hope-frost@haymarket.com

CHIEF SUB-EDITOR
Marcus Simmons ext.5807
marcus.simmons@haymarket.com

NATIONAL EDITOR
Ben Anderson ext.5425
ben.anderson@haymarket.com

SENIOR DESIGNER
Michael Cavalli

PICTURE EDITOR
Peter Mills ext.5918
peter.mills@haymarket.com

AUTOSPORT.COM TECHNICAL TEAM LEADER
Geoff Creighton
geoff.creighton@haymarket.com

AUTOSPORT.COM DEVELOPER
Tomasz Trznadel
tomasz.trznadel@haymarket.com

AUTOSPORT.COM USER INTERFACE DEVELOPER
Theo Pape
theo.pape@haymarket.com

OFFICE MANAGER
Joanne Grove
joanne.grove@haymarket.com ext.5804

PHOTOGRAPHS
LAT Photographic

SPECIAL CONTRIBUTORS

Mark Hughes	Dieter Rencken	Jim Bamber
Gary Watkins	Gary Anderson	Pablo Elizalde
Marcus Pye	Giorgio Piola	Matt Beer
Mark Glendenning	Alan Eldridge	

CORRESPONDENTS

ARGENTINA Tony Watson	ITALY Roberto Chinchero	Martin, David Phillips, Diego Mejia, Robin Miller, Jeremy Shaw
AUSTRALIA Phil Branagan	JAPAN Jiro Takahashi, Len Clarke	UK & EIRE Jonathan Crawford, Dan Cross, Kerry Dunlop, Leanne Fahy, Paul Healy, Paul Jurd, Linda Keen, Mark Libbeter, Stephen Lickorish, Scott Mitchell, Marc Orme, Graham Read, Hal Ridge, Peter Scherer, Ian Sowman, Oliver Timson, Ian Titchmarsh, Matt Upton, Eddie Walder, Richard Young
AUSTRIA Gerhard Kuntzsch	NEW ZEALAND Bernard Carpinter	
BELGIUM Gordon McKay	RUSSIA Gregory Golyshv	
BRAZIL Lito Cavalcanti	SOUTH AFRICA Richard Asher	
FINLAND Esa Iloninen	SPAIN Raimon Duran	
GERMANY Rene de Boer	SWEDEN Tege Tornvall	
GREECE Dimitris Papadopoulos	USA Jonathan Ingram, Bruce	

ADVERTISING
Tel: +44 (0) 20 8267 5820
Fax: +44 (0) 20 8267 5850
E-mail: autosport.ads@haymarket.com

COMMERCIAL MANAGER
Rachel Brock, ext: 5820
rachel.brock@haymarket.com

DISPLAY ADVERTISING
Gary Lee Hoebbeck, ext: 5276
gary.lee.hoebbeck@haymarket.com

ONLINE ADVERTISING
Alex Newberry, ext: 5244
alex.newberry@haymarket.com

PRODUCTION MANAGER
Ailsa Donovan, ext: 5639
ailsa.donovan@haymarket.com

PRODUCTION CONTROLLERS
Geeta Chambers, ext: 5588
geeta.chambers@haymarket.com

DIRECTORY ADVERTISING
Emily Clark, ext: 5865
emily.clark@haymarket.com

SUBSCRIPTIONS
UK 0844 8488817
OVERSEAS +44 (0)1795 592 974

EMAIL
autosport@servicehelpline.co.uk
AUTOSPORT, ISSN number 0269946X, is published weekly by Haymarket Media Group, Teddington Studios, Broom Road, Teddington TW11 9BE, United Kingdom. The US annual subscription price is \$225. Airfreight and mailing in the USA by agent named Air Business Ltd, c/o Worldnet Shipping Inc., 156-15, 146th Avenue, 2nd Floor, Jamaica, NY 11434, USA. Periodicals postage paid at Jamaica NY 11431. Subscription records are maintained at Haymarket Media Group, Teddington Studios, Broom Road, Teddington TW11 9BE. Air Business Ltd is acting as our mailing agent.

BACK ISSUES
Tel: 0844 8488817

MARKETING MANAGER
Karen McCarthy, ext: 5658
karen.mccarthy@haymarket.com

LICENSING AND SYNDICATION
LICENSING MANAGER
David Ryan, ext: 5024

DIGITAL SPECIAL PROJECT MANAGER
Simon Strang, ext: 5093
simon.strang@haymarket.com

DIGITAL PRODUCT MANAGER
Simon Grayson, ext: 5346
simon.grayson@haymarket.com

CIRCULATION/TRADE ENQUIRIES
Frontline Ltd, Park House, 1 Park Road, Peterborough, Cambs, PE21 2TS. Tel: +44 (0)1733 555161. Printed in England by Wyndeham Heron Ltd. Cover and centre sections printed by CSM Impact, Basingstoke. Colour origination: FPM, 90-92 Pentonville Road, London N1 9HS. ISSN 0269-946X. AUTOSPORT, incorporating Autoclassic, is published weekly by Haymarket Consumer Media, Teddington Studios, Broom Road, Teddington, TW11 9BE, UK.

EDITORIAL DIRECTOR
Mark Payton

CREATIVE DIRECTOR
Paul Harpin

STRATEGY AND PLANNING DIRECTOR
Bob McDowell

PUBLISHING DIRECTOR
Patrick Fuller

MANAGING DIRECTOR
David Prasher

CHIEF EXECUTIVE
Kevin Costello

Haymarket is certified by BSI to environmental standard ISO14001

haymarket

THIS WEEK

LETTERS • BEST PICS • LATEST GEAR • ON TRACK & SCREEN • ONLINE

What you think of the motorsport news of the past week



Should Vettel have let Webber win in Brazil?

ROBERTSON/GETTY

Vettel misses sporting chance

There we were, on the verge of what could have been the greatest sporting act ever.

Webber had just passed Alonso into second place, the race was reaching its conclusion and all the while those immortal words echoed in our heads:

'Multi 21, multi 21...'

Would Vettel let his team-mate pass him as payback for ignoring team orders at the Malaysian Grand Prix?

And the winner was... the record book!

Jerry Martin, Sidcup, Kent

It never ceases to amaze me

how the decision-makers come up with rules that result in ugly F1 cars (Formula 1's ugly future, November 21).

Surely the combined minds of some of the top engineers/designers in the world could devise rules so that the cars at least look nice, but it seems common sense goes out the window.

The trouble is, F1 design dictates the look of the cars in the lower formulas, and of course these look terrible as well.

**Michael Skeet
Southampton**

Another season is over. Another

season has been given the precious veil of oblivion by Lady History and Lord Remembrance.

And I am sitting here, lamenting on what to do until next March, when my favourite symphony orchestra starts playing the overture. I know this condition is not permanent, yet I feel every now and then mild panic.

I enjoyed this season, as I enjoy every one of them, and although some claimed it was dull, even they, the haters-and-

boosers, kept watching this masterpiece, didn't become alcoholics after Vettel's third or fourth of victories and went on with their complaining – but they didn't quit, and there's no need to ask why.

After all, it takes time to make things shine in their deserved beauty and glory. Until then and until spring, I push the replay button.

**Gyimesi Brigitta
By email**

Martin Whitmarsh sacks Perez

then spends time attempting to get his failed driver a seat at Force India. He then says he is sorry for Paul di Resta.

This is an indictment of the failed business model Bernie Ecclestone has created. Inferior pay drivers still have a drive while the only man to have beaten Sebastian Vettel in a championship with identical machinery does not.

**David Stuble
Prestwick**

This year has been a total catastrophe with regards to the FIA penalising F1 drivers. 'Causing a

collision' is for me a ridiculous rule. Several times this has been a racing incident. And the hottest topic of all: the white line. Penalise Grosjean's excellent overtake on Massa in Hungary? And now penalise Massa for crossing the pit entry line in Brazil? That's enough!

**Patrik Knoos
Saffle, Sweden**

Many thanks for including the

method of points scoring in your race results. I've no doubt this has increased readers' interest in and understanding of the progress of the many series covered.

**Brian Winstone
Saffron Walden, Essex**

CORRECTION

We mistakenly attributed a comment to David Thomas on page 83 in last week's issue (*Drivers excluded after paddock altercation*). Thomas made no contribution to the story. All comments came from MSVR race operations manager David Scott. Apologies for the error.



In pictures

Images around the globe, from the United States to Brazil



CATERHAM ENDS WITH A BANG
The Caterham F1 team decided to bid farewell to the 2.4-litre V8 engine era by detonating one its Renault RS27 powerplants in the garage at the end of the Brazilian GP

COATES/LAT



MONTOYA BACK WHERE HE BELONGS
Thirteen years after he last drove a Indycar, former champion Juan Pablo Montoya was back in action for Penske at Sebring ahead of his 2014 series return

WEBB/LAT

CLOSE SHAVE FOR HEIKKI
Despite Brazil being the last of two outings for Heikki Kovalainen at Lotus, we think the Finn got away with an end-of-term waxing from his mechanics...



WEBBER CREW MAKE MARK
Mark Webber's mechanics wore hats and T-shirts to honour their man as he made his 215th and final GP start in Brazil before quitting F1 for sportscars



THOMPSON/GETTY

In the shops

Desirable new releases

JIM CLARK MEMORIES BOOK

£15 – autosport.com/shop

Winning the World Championship with Jim Clark is a personal and intimate account of life alongside the Formula 1 hero by South African mechanic Cedric Selzer, who settled in the UK and landed a job with Lotus. Selzer tells the story of Clark's dominant 1963 season, in which he won seven of the 10 GPs in Colin Chapman's Lotus 25 to land his first world title. It's a charming and engaging tale of life on the F1 frontline half a century ago.

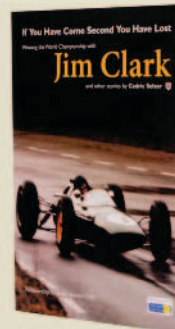

ASTON MARTIN KEYRING

£9.99 – autosport.com/shop

Not all official motorsport team merchandise will break the bank, as this Aston Martin Racing keyring proves. The team's World Endurance Championship GTE Pro-class DBR9 racer is replicated, with all the correct sponsors' logos and colours, and comes attached to a secure but easy-release ring to keep all your keys together. It's a good time to pledge your allegiance to the team, too, as it heads to this weekend's WEC finale in Bahrain looking to secure title glory for Darren Turner and Stefan Mucke.



MARIO ANDRETTI 1:8 HELMET

£29.99 – autosport.com/shop

We're hoping TrueScale Miniatures has started a bit of a trend with its 1:8-scale replica of the Bell helmet worn by Mario Andretti during his world championship-winning season with Lotus in 1978. The helmet comes with accurate branding, a tinted visor and is mounted on a numbered plinth for ease of display. Let's hope other F1 legends' lids from the 1970s and '80s join the set.



WHAT'S ON

ON TRACK IN THE UK



If you like FF1600, put your coat on and head to Anglesey

ANGLESEY

BRSCC

December 1

angleseycircuit.com

As we enter the final month of 2013, there is one final opportunity for hardy club racers to get some competitive on-track action. The last meeting of the season comes at the iconic Anglesey circuit, which once again hosts the BRSCC's Winter Raceday. Formula Ford 1600 races will headline the Sunday event on the Coastal circuit, supported by grids of Caterham-type and Open sportscars, Sports/Saloons and a two-driver endurance race.

JAKOB EBREY

ON TRACK AROUND THE WORLD

88



Can Toyota make up for its recent defeat at Shanghai?

JAMES MOY

WORLD ENDURANCE CHAMPIONSHIP

Rd 8/8

Sakhir, Bahrain

November 30

fiawec.com

Allan McNish, Tom Kristensen and Loic Duval secured the title last time out in China, so the finale promises to be a no-holds-barred affair as Audi and Toyota duel for the final time in 2013. There are also the class titles to be decided in the Bahraini dust.



All to play for in the GTE title fight in Bahrain

DPPI



MRF heads west from India

MRF CHALLENGE

Rd 2/4

Sakhir, Bahrain

November 29-30

mrfracing.in

NZ V8 SUPERTOURERS

Rd 7/7

Pukekohe, New Zealand

November 30-December 1

v8st.co.nz

SUPER TC2000

Rd 12/12

Potrero de los Funes,

Argentina, December 1

super-tc2000.com.ar

Your guide to the best events taking place in the UK and around the world – plus TV and online

ON TELEVISION

THURSDAY NOVEMBER 28

0200-0300, 1900-2000 Sky Sports 2

Max Power

0500-0530 ESPN

Planet Speed

0650-0900, 1310-1545 Motors TV

V8 Supercars: Phillip Island Highlights

1105-1310 Motors TV

FIA GT: Baku Highlights

2205-2305 Eurosport

Blancpain Endurance Series:

Nurburgring Highlights

2305-0005 Eurosport

ERC: 2013 Season Review

FRIDAY NOVEMBER 29

0300-0400 Sky Sports 3

Racemax

0720-0900 Motors TV

FIA GT: Baku Highlights

1000-1100 Eurosport 2

Blancpain Endurance Series:

Nurburgring Highlights

SATURDAY NOVEMBER 30

0355-0420 Channel 5

Motorsport Mundial

0600-0615 ITV4

World of Sport: Petrol Heads

0600-0810 Motors TV

V8 Supercars: Phillip Island Highlights

0610-0720 Channel 4

FIA GT: Baku Highlights

0920-1015 ITV4

Motorsport UK

1130-1835 Motors TV LIVE

WEC: Bahrain 6 Hours



Baku FIA GTs appear on Motors

1200-1215, 1700-1800 Eurosport LIVE

WEC: Bahrain 6 Hours

1800-1900 Eurosport

FIA GT: Baku Highlights

1855-2305 Motors TV

Superstars: 2013 Season Review

2030-2115 Eurosport

WEC: Bahrain Highlights

SUNDAY DECEMBER 1

0600-0700 Sky Sports 3

Racemax

0705-0800 Channel 4

FIA GT: 2013 Season Review

0700-0730 ESPN

Planet Speed

0935-1240, 2305-0215 Motors TV

WEC: Bahrain 6 Hours Highlights

1650-2100 Motors TV

ALMS: 2013 Season Review

MONDAY DECEMBER 2

0215-0305 ITV

Motorsport UK

2000-2305 Motors TV

WEC: Bahrain 6 Hours Highlights

ONLINE

HOT ON THE WEB THIS WEEK

YouTube PENSKE TAKES ONLY F1 WIN IN 1976 AUSTRIAN GP



SEARCH FOR: Grand Prix Legends - 1976 Austrian GP (3:14)

When you've read the story behind Penske's victory in the 1976 Austrian, as retold on page 56 by John Watson and Roger Penske themselves during a recent – and rare – get-together, you ought to watch this highlights clip – just to see if their memories are still up to it.

AUTOSPORT+

Exclusive content coming up in our premium website this week

Craig Scarborough delves into the secrets of Red Bull's RB9 to discover just what made it so good, while David Evans looks at Robert Kubica's progress in world rallying. Plus, coverage of the AUTOSPORT Awards, including the 25th McLaren AUTOSPORT BRDC Award winner.

GET AUTOSPORT ON THE MOVE

- IN THE IPAD ISSUE THIS WEEK...
- WATCH AUTOSPORT DRIVE THE 2013 BTCC TITLE WINNER
- ON SALE ALL OVER THE WORLD FOR ONLY £2.99

Download it now from autosport.com



Revved up over what's on the box



It's all over for Mark Webber – in F1

APPARENTLY MARK WEBBER'S retiring. Someone had better tell Porsche or it's going to be a driver short for the World Endurance Championship next year.

Actually, you could have been forgiven for thinking that Webber was up for some 'Pride of Australia' style award for battling a life-threatening disease such was the cloying, ballad-strewn tone of the coverage of his 215th and final grand prix.

The BBC started its Brazilian GP show joining a reflective Aussie as he made his way to the F1 paddock for the final time.

"It's not a sad moment, it's a proud moment," he said, despite the faint tears in his eyes betraying his words.

Red Bull got it right, blaring out *Waltzing Matilda* and other cliched Aussie tunes as

Webber walked into the garage, but then it was back to the lachrymose strains of Coldplay and another montage of Webber's F1 career from the Beeb.

"It was great listening to Mark," said Suzi Perry, "there won't be a dry ice, eye, in the house."

Finally it was left to DC to chime in that this wasn't the end of Webber's career and that he was in fact moving on to race sportscars. Hallelujah!

And then, on the gridwalk, whom should DC head to... Mark Webber!

"A few touching Aussie songs from the team there, now I just want to focus on the race," Webber offered before climbing into his Red Bull. He could have added "and stop answering bloody questions about

whether I have any regrets".

There was some lip service paid to Felipe Massa leaving Ferrari after a record-breaking stint in red, but little on the ever-shifting, compelling and unpredictable tussle for the midfield seats that could very well end the career of whoever's left standing when the music finally stops and the cheques clear.

And there was nothing on Cosworth – a legendary British engine manufacturer who fought a brave rear-guard effort against the might of the big marques before calling time (for the last time?) on building F1 engines when the word became obsolete and 'power units' took over. Surely that was worth marking, too? **Revved Up**

Tommy Kristoffersson

“It was very emotional – it was the race everything came together”

■ FIA European Rallycross ■ Arvika, Sweden ■ June 6, 1998 ■ Audi Coupe S2 ■ Victory at home



ALL PICS: TONY WELAM

DEFINITELY, IF ANYBODY asked me which race I remember best, this would be the one I would choose. We had this race in our home town of Arvika in Sweden, at a track called Westombanan. We had done the round of the European Rallycross Championship there for the three years before, but we broke the car and we rolled it – so it was always kind of a disaster. So, we were trying pretty hard.

I was driving the Audi S2 we had been using for many years. We were alone with that car and tried to develop it year by year. The whole time we were running into problems.

Finally, that weekend it held together and all the hard work we put into it paid off. It was definitely the most powerful car at the time – we had over 700bhp. There were a lot of spectators there and a lot of fans liked the Audi – not just because of the brand, but also the special sound from the five-cylinder engine. It was perfect to drive.

We hadn't done any rallycross races that year because it was the year we stepped from rallycross to circuit racing. The other guys had been out all year and didn't expect us to be quick or to push them.

Because it was in front of our home crowd I always had in my mind that there were problems at this event. We were a little nervous, but,

in practice on the Friday we were fastest and we were fastest all weekend, and grabbed the win.

For me this was something extra special. We were fastest in every outing with fastest lap and fastest heat time. It was a hard fight with Martin Schanche: I lost the lead once and then I overtook him again. It was the same with Kenneth Hansen – he

was in front of me at one point but I overtook him again. It was the right guys with me: Martin, Kenneth and Michael Jernberg, the guys I had been fighting with for years. It was very emotional to finally beat them in front of my friends and the home crowd. It was really the race when everything came together.

I decided pretty quickly afterwards that it was the last race in rallycross for me. We had achieved what we wanted to. After I crossed the finish line I threw my helmet into the crowd and it was over. I think the other guys were delighted that finally I could win because they understood it meant a lot to me. I couldn't see any angry faces that day and we had a big party afterwards, which I only remember the start of! When we entered the restaurant in the evening, a table was already reserved for us by our competitors – it was nice of them to celebrate our win. *Tommy Kristoffersson was talking to Hal Ridge*

PROFILE



TOMMY KRISTOFFERSSON

competed in rallycross with an Audi for the majority of his career, before embarking on a career in the Swedish Touring Car series from 1998, still with Audi. The 54-year-old retired from full time driving to concentrate on running his Kristoffersson Motorsport team, which fields VW Sciroccos in both circuit racing and rallycross. His son Johan is one of the drivers.

NEXT WEEK FAREWELL TO DARIO FRANCHITTI
Plus: AUTOSPORT Awards: the winners



MOTORS
LIVE TV

SKY GUIDE 447
VIRGIN MEDIA 545



SATURDAY
FROM 11:30

FIA WEC FINALE
6 HOURS OF BAHRAIN - LIVE!



SEAT

THE NEW SEAT LEON

From just **£169** per month
with **£1,915** of free equipment*



NAVIGATION SYSTEM

FULL LED HEADLIGHTS

DAB DIGITAL RADIO



ENJOYNEERING

SEAT Leon 5DR 1.2 TSI SE – Solutions representative example based on 10,000 miles per annum**

Duration:	36 months	SEAT UK Deposit contribution†:	£1,000.00	Optional final payment:	£7,600.19	Amount of credit:	£12,308.63
35 monthly payments of:	£169.00	Retail cash price:	£16,970.00	Option to purchase fee²:	£60.00	Representative APR:	4.9% APR
Customer deposit:	£3,661.37	Acceptance fee¹:	£125.00	Total amount payable:	£18,361.56	Rate of interest:	4.10% fixed
Full deposit:	£4,661.37	Total payable by customer:	£17,361.56				

4.9% APR representative plus £1,000 towards your deposit†

FOLLOW US ON: **SEAT.CO.UK**

Official fuel consumption for the New SEAT Leon range in mpg (litres per 100km): urban 36.7 (7.7) – 61.4 (4.6); extra-urban 57.6 (4.9) – 85.6 (3.3); combined 47.9 (5.9) – 74.3 (3.8). CO₂ emissions 137 – 99g/km.

Standard EU Test figures for comparative purposes and may not reflect real driving results. Model shown is the New Leon 1.2 TSI 105PS SE at £16,790 RRP with optional electric sunroof at £695 RRP, 17" Dynamic alloy wheels at £350 RRP and full LED headlights at £995 RRP. Offer may be varied or withdrawn at any time. Retail Sales only. ¹Payable with first payment. ²Payable with optional final payment. 4.4p per mile excess mileage charges apply. †£1,000 deposit contribution is available to customers who purchase their car with Solutions personal contract plan. Terms and conditions apply. Finance examples include technology pack. Further charges may be payable if vehicle is returned. Indemnities may be required. Subject to vehicle availability. Subject to status. Available to over 18s in the UK from participating dealers only. SEAT Finance, Freepost SEAT Finance. Subject to each model specification and cost option fitment. Pricing and finance valid from 1st October to 31st December 2013. **Offer available on SE and FR models when ordered before 31st December 2013 from participating dealers only. *£1,915 RRP refers to optional specification if priced individually.

SEAT recommends Castrol EDGE Professional