



Thermal publication and Open Source publishing, FR0, Paris, 2018

THERMAL MANIFESTO ~ THERMAL HOUSE

Thermal Manifesto is named after the inkless printing technique for receipts from cash registers. With help of Open Source software tools and driver is possible to start to use this method for self-publishing.

Low-Res brings Max-Authenticity.

Halftone Raster of 1950s newspaper is very nice.

Read your rolls quick, after 2 years, print might be gone.

When you finish, please rewind. Same like VHS rule.

You can re-print your prints and add extra, new layer.

Works both; horizontal and vertical.

Developing a very light and movable system for a transportable publishing desk, which can deploy in various environments. Cooperative and inclusive potential is highlighted. Works and publications can be produced flexibly without a long chain of service and postproduction steps with locally available material and in sustainable amounts.

Reducing the print format (print rolls of 47mm width) and print quality to half-tone black and white raster has a refreshing touch, contrasting with the overwhelming presence of contemporary glossy images.

Thermal Manifesto print questions how publications are designed. Authors and readers are confronted with a page-less, endlessly designed, reading experience. Final prints are compact, on light-weight paper.

Public activities with project are prepared as way to discuss topic of self-printing and personal technical renaissance.

→ <https://vimeo.com/411579237>

THERMAL MANIFESTO PRESENTED AT

Fanzine, Eternia, Prague, 2019

Miss Read, HKW, Berlin, 2019

Druck, Druck, Druck, Berlin, Gallerie am Koerner Park, Berlin, 2019

Prints for Ciocana with Oberliht, Chisinau, Moldavia, 2018

Absurdité, Trojan Tactics, Decazeville, France, 2018

Toulouse Salon, France, 2018

Baykonur ~ Berlin, Lichtenberg Studios, Berlin, Germany, 2018

Thermal publication and Open Source publishing, FR0, Paris, 2018

+ as part of Trojan Tactics Activities

MOVEMENT JOINED BY

[Gemini Kim](#)

[Sébastien Mazauric](#)

[Aleksi Cavaillez](#)

[Artus De Laviléon](#)

[Thibault Montamat](#)

[Nina Prader](#)

[Cosa](#)

[Trojan Tactics](#)

[Imm](#)

Ildiko Many

Patric Kurth

Milan Valeš



Baykonur ~ Berlin, Lichtenberg Studios, Berlin, Germany, 2018

BAIKONUR IS FOR ONE NIGHT OPERATED FROM LICHTENBERG

Lichtenberg studio activities were dedicated to Self published Books, electronic experiments and constructions with topic of Electronic Error, Hair Internet, Laser Random drawings, videos of Work and Running sky, Zip Bags, theory of *Vladimir Paperny* described in *Culture "Two"* and *Liu Cixin's* novel *The Three-Body Problem*, smell of Lichtenberg and caffeine habits exploration, Steel Engraving, Thermal publishing house and live prints, strong Turkish tea, Chicken + Fish slow motion.

These topics were presented during composed evening:

Baikonur ~ Berlin "*Baikonur is for one night operated from Lichtenberg*"

In form of Open Studio evening was made parallel to cosmodrome hub.

Every visitor obtained publication summarizing my work in Lichtenberg and ZIP-bag, designed to survive and experience Friday Night Cosmos-Space Walk in Berlin.

Laser Lines and Posca Lines Blending tested on studio wall with Sébastien Mazuaric.



Micro publications, Archip, Praha, Czech, 2018

THERMAL HOUSE

Idea of mobile and flexible Print house and print studio. Prints are cheap, flexible and portable. Encouraging local writers, poets, illustrator to publish and share. (also as result and issue of Copyright wrong and anti cultural policy → necessity to link and publish authors pieces, rather than big names of Literature, except the one from Free Libraries.). We can imagine place, where people have a coffee, and meanwhile their selection of literature and other content from “menu” is printed, shared, and accessible for visitors.

HUMAN POST

HUMAN POST IS A SERVICE
OF POST DELIVERY DONE
BY PEOPLE PERSONALLY.

SUBSTITUTING WIDELY
PROVIDED STATE POST SER-
VICE. ORGANIZING IN
SMALL COOPERATIVE

GROUPS AND DELIVERING
POST IS INTERCITY-URBAN
ADVENTURE.

FEEL KINDLY INVITED INTO
THIS MOVEMENT BY FINDING
ORIGINAL WAY, HOW TO
DELIVER FOLLOWING POST.

Human Post, Center for Art and Urbanism, Berlin, Germany, 2017

HUMAN POST

Project using medium of real post, and its huge authenticity and human potential. Sending letters is becoming some rare and luxurious activity. Post boxes usually full of spam and advertisement ballast. Contrary to times, when having thick and numerous correspondence was daily routine. Project try to re-start interest into post sending. Includes citizens to share and bypass post service, by self delivering. As sort of Urban Game of Connection.

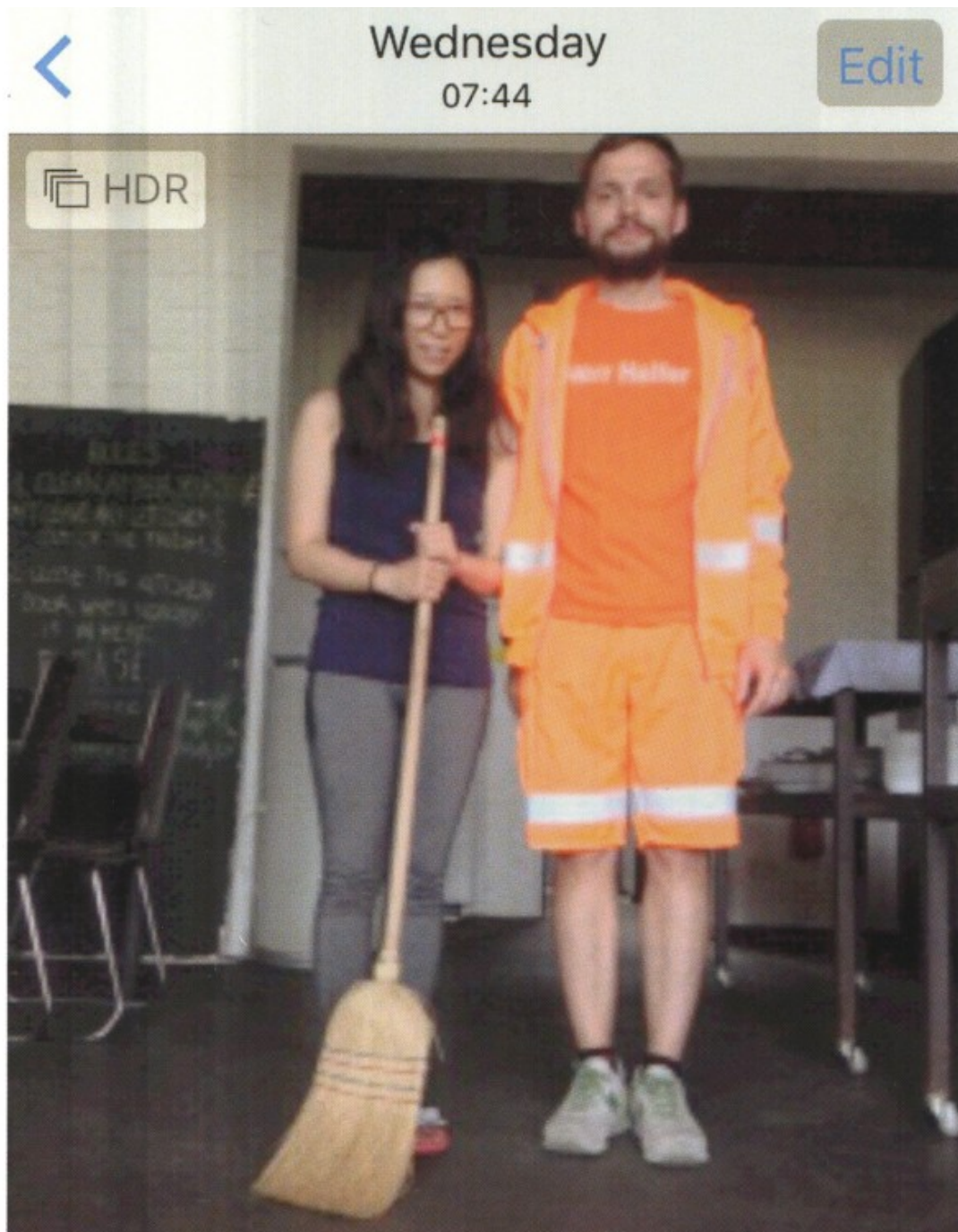

BSR, Artist displacement, Berlin, Germany, 2016

TRUE IS; WHERE TRASH IS

6 months displacement at Berlin sanitation company (BSR) and roofed by ZK/U Berlin.

PROJECT LINK

→ homeiswheretrashis.tumblr.com

POSTCARDS

The postcards have been created during six month (July~December, 2016) Artist Displacement project at BSR, Berlin. They are my personal reflection on world of sanitation within the company I was able to enter.

OUTPUT CONTENT

28 postcards, 4 interactive postcards, glitter



ISO, Amsterdam, Netherlands, 2016

ISO CAFÉ IN AMSTERDAM AT JAVA ISLAND

3 months Art residency in metal box of ISO container at Java Island.
Repairs, caffeine, rain, wind, sun and improvisations. Also chance to people.
Supported by Elia organization and by enthusiasts.

ISO

An intermodal container is a large standardized shipping container, designed and built for intermodal freight.
→ amsterdaminiso.tumblr.com

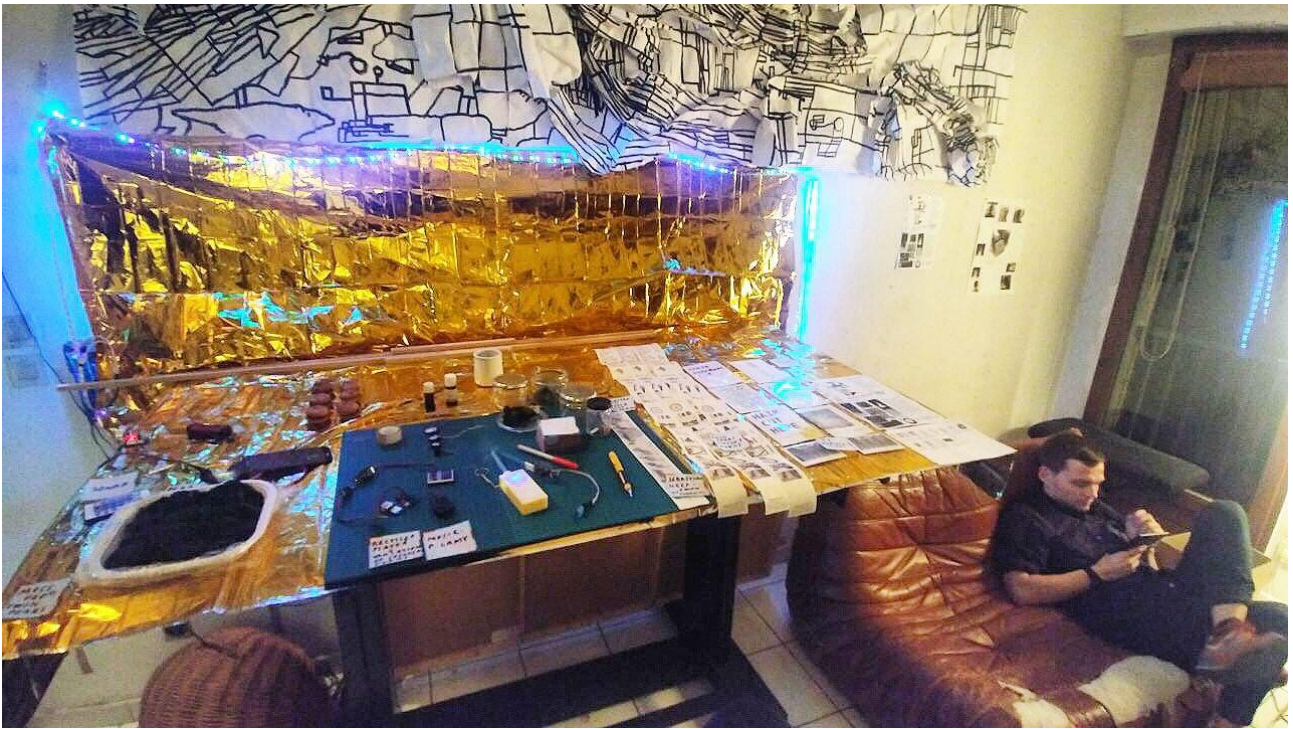

Toulouse Salon, France, 2018

TOULOUSE SALON

Presentation of Electronics, Line and Laser drawings and Moss cultivation in form of 3rd space environment. Dead display, LED stripes, Moss, TT Videos, Temperature and Humidity online sensor, Thermal prints from sky~ceiling, VV Publications.

Trojan Tactics Salon Presentation and chat.

Nicolas Galian ~ Cakes

Sebastien M. ~ Lines with Ink

Viktor V. ~ Lines with Laser

Philippe Lamy ~ Music via recycled speaker and player

Toulouse, December 2018.



Absurdité, Trojan Tactics, Decazeville, France, 2018

ABSURDITÉ

Trojan Tactics arrived on the 3rd, and are using since then the former optical shop on the 55 rue Cayrade as a work space on display. They managed to clean it and lower the level of humidity from a 85% to an all time record of 25%. Working conditions are good, the interior and exterior lights are working again and our activities can be commented and experimented.

The cafés, the boulangeries, the Spanish descendants (TOP), the kids, everybody is helping in a way, there is sense of welcomed energy in dying street.

Our space will be shut down on the 22nd of September, and gain again high humidity.

As part of TT studio in former Optics shop in “mutating” area of town Decazeville I issued self-published magazine Absurdité.

Magazine was articulating activities and connection with unique atmosphere and topography of former mining town Decazeville.

With coop intervention run-down shop was changed into 24/7 operating Cultural spot, Art studio and venue for music events.

Our project also included inspecting broader area of Aveyron department in the Occitanie region. Gaining sense for local habits, living and cultural situation.

I used the Studio / Kiosk space for testing projects as *HAIR INTERNET* and *ELECTRONIC REPAIRS PHILOSOPHY*. As well as starting first prints and publications with help of Thermal Printer.

At Run in party → Clean studio Celebration.

Friday Deca-mood.

Played Hinterheim and Undude

3rd of September 2018 → 21st of Septembre 2018



Prints for Ciocana with Oberliht, Chisinau, Moldavia, 2018

PRINTS FOR CIOCANA

Project of self-run improvised pop-up 3 weeks Art studio and graphic workshop in former Chisinau Agriculture Museum building. Participants were using the studio 24/7 mode, switching from full work to full party modes intuitively.

Outcome of studio operation was publication spread in Maria Dragan street and between citizens of Chisinau, capital of Republic of Moldova.

Street on WikiMapia
wikimapia.org/street/131486/ro/Str-Maria-Dr%C4%83gan



Ø, with Thomas O'Grady, Silkeborg, Denmark, 2017

Ø

Work researching about specific character “ø” in Danish town Silkenørg with artist Tohoma O’Grady. Different typographic and materials were used in 1 month research. Final presentation for public took in Municipal Library and Culture Hall.



Open Circuit, 3rd space of Trojan Tactics, Seoul, Korea, 2017

3RD PLACE IN OPEN CIRCUIT GALLERY

As Trojan Tactics we have worked, presented and actively survived for 2 weeks in fascinating environment of Seoul biggest Electronic Market Sewoon Sangan.

Through this time we have become close to all kind of area users. We have witness gentrification process of area and its transformation. We have seen magical moments of 8:00 pm, when all electricity is centrally shut down and we did collected and used waste material for our works.

Our project was traditionally based on strong connection with context of place. Spending actively all possible time slots at area, using materials found and obtained in area and keeping social contact with all kind of professions and roles of users of this area. Such methodology help us to achieve deeper insight into problematic and complexity of topics we encounter and articulate in our works.

Some inspiration, knowledge and material were at end of project transported to our Incheon studio and processed into "Pagoda Walk" social performative sculpture.



Pagoda Walk, Trojan Tactics, Incheon, Korea, 2017

PAGODA WALK

Performance Homage to materials and Social and Collective habits of Seoul. We collected materials in Area of Incheon small streets [our living environment for 3 months] and materials collected at Sewoon Electronic Market at Eujiro Samga station [our pop-up studio space].

The Events and Food habits were introduced us by our colleague Gemini Kim as well as observed from daily live routines.

Those exclusive and content filled materials were transformed in functional Pagoda, including light and sound effects powered from Batteries, food cabinet ~ cooled down by ice blocks as well as bar, cooking gas-device and sitting solution for visitors.

With help of Incheon Avantgarde members and Mazauric family members We walked Pagoda to most charismatic Incheon Harbor corner where was also check point for ceremony.

→ vimeo.com/319304070



Hair Interner, Hair cut performance, ongoing work

HAIR INTERNET

Inter community service. How can Artist help each other? What can be invested into community?
Hair Internet ~ continual manifesto of self education and pro~community knowledge and machinery sharing. Research about different styles, matter and typology of hair inside Art and Culture micro~society. Observing of reactions of Hair Internet Participants, once their head is being clipped.

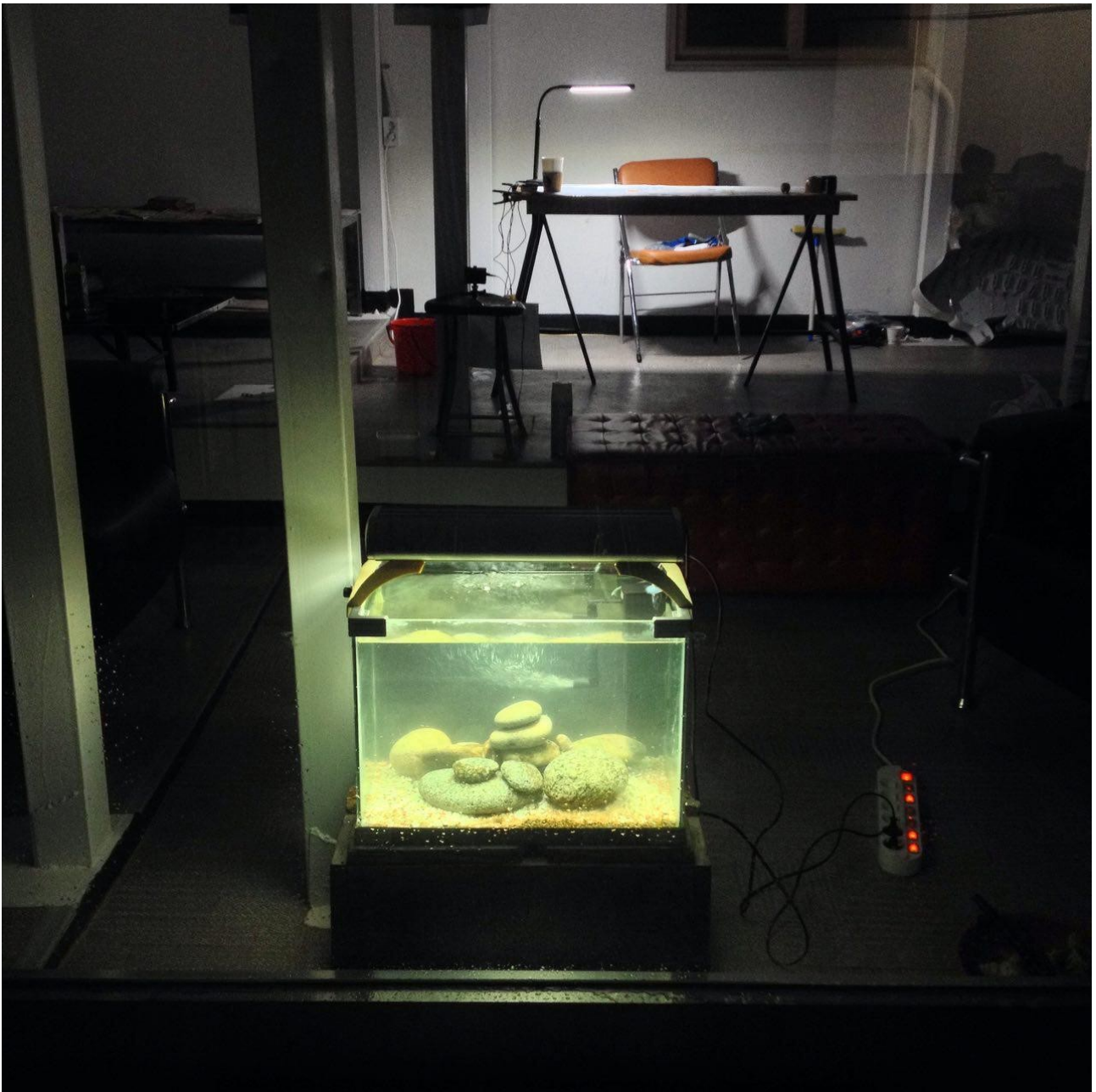

Incheon ~ 3 months Fish Tank experiment, Korea, 2017

FISH TANK

Working in 3rd Space in Wuri pop-up Studio. Incheon, South Korea, 2017 for 3 months. My experiment was to grow local life and aesthetic fish-tank for 3months. At beginning the fish-tank contained only clear tank, water, stones. In Period of 3 months new spectrum of life, such as algae and microorganism developed in fish tank. Turning from crystal clear to green tone color. Also project was reacting on weather changes from early spring cold to late spring warm.

Ethically is work reacting on countries philosophy and fascination with live, water presentation in street. In sense fish tanks were meditative and aesthetically fascinating objects to watch. Much more acceptable and contemplative than for example watching of Television.



Engraved daily cutlery, Lichtenberg studios, Berlin, 2018

STORIES IN STEEL

Fascination with engraving technique. Study of hand typography (India inspiration, gravestones, ornamentation, Industrial Engraving). Idea connected with Thermal House, best sentences and quotations can be engraved into stable objects: glass, steel, stone, wood. Need material, time, and focus. Meditation focus. Any mistake means disaster.



Dell D430, Linux conversion and machine resurrection, 2019, Prague

LINUX BAPTISM

Opening Kiosk, where old but usable machines are turned to Linux running machines. Fast enough to maintain all office and surfing experience. Saving Hardware by installing Software. And relieving citizens from paid software relation.



Mobile Publishing House parked under tree in rainy night, Berlin, 2019

BIKE ACTIVITIES

Scanning and exploring area with bicycle. Forming small cycling units. Encouraging others to use bicycle as transport and relax tool. Developing sound system and visual system for bicycles trips and happenings.



Diagram Reservoir, published at Thermal House, Prague, 2019

DIAGRAM RESERVOIR PUBLICATION

Publication express and summarize my fascination with hand drawn and written diagrams. Often they are the basic stones of my ideas and mind process. I think they have true humanistic potential of containing human ideas, fascination and process of mind. They can be rude, complex, pornographic, belletrist, wrong, perfect and any other form. Diagrams are also honest, and mostly without any self-censorship.

TRANSLATION

MEMBER
CAN REQUEST
BUT ALSO DELIVER
OTHERS MEMBERS
TEXT TRANSLA-
TIONS. IN ORDER
TO FORM
ALL MEMBERS
LANGUAGE VARIANTS.

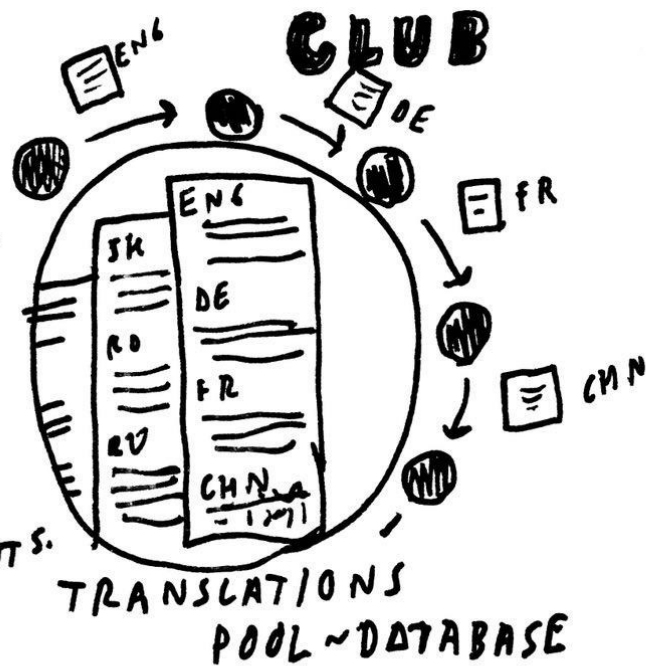

Translation Club, Prague, 2019

TRANSLATION CLUB

Idea of formation of individuals who willing to cooperate in Lettrist + Translation movement. Each member of the Club has right to ask for translation of cultural texts but also his honor duty is to translate texts of his colleagues.



Laser Lines, Human Lines, Toulouse, 2018

HUMAN LINES, LASER LINES

Symbiotic idea of very ambivalent yet well cooperating methods and ideology. Sébastien Mazauic is delivering his universe of abstract modernist line complexity. Viktor Vejvoda adjust and build laser line randomizes, creating subtle second layer but also kinetic guide line and interaction with Sébastiens murals.

<https://vimeo.com/318996948>



LEBEDIVKA BUS STATION CULTURE CHECK POINT. SUMMER 2019

LEBEDIVKA BUS STATION

As part of expedition to Lebedovka area (Odes'ka Oblast, Ukraine) exhibition space at local bus station and travelers spot was established Spreading self printed samizdat mini prints with latest news about our life and work in Kishinev. This was tiny symbolic act for uniting intellectually territories with human story and simple summer perception of natural area. Prints were soft-attached on wall. Expedition was as well documented in self-published experimental book "Lebedivka Diaries, 2019" published in Chisinau together with Max Vladimirovich Palyakov.



OPEN STUDIO ENVIRONMENT, Muzeum Zemstvie, Chisinau, 2018 and 2019

OPEN STUDIO ENVIRONMENT

Collective operated and maintained studio space realization. In summer months of year 2018 and 2019 multi-functional open form studio in Muzeum of Agriculture in Kishinev was established. Space with central table place for developing and realization of our publications. It held photographic and typographic workshops and numerous small half days activities such as digital and analogue camera reverse engineering. Important value of space was it could offer some urban shelter service providing visitors with place to sit in garden and hot tea or coffee. This helped us establish open, non-hierarchical and intuition operated space. In current time 3rd year of continuity is being discussed.



ALCATRAZ COFFEE BAR, 2019, Botanica, Independenței, Chisinau

ALCATRAZ COFFEE BAR

Attempt to Revitalize and repurposed former Disco Bar into one night pop-up cultural venue. Collectively cleaned, equipped and run for few days bar area as new functionality reading spot. Bar was containing instead of alcohol, publications and Coffee was offered for free as part of act of cultural experience.

Event was including our music and art producing friends and forming rather than self-representing event, event which blends and unite on basis of cultural enthusiasm.

PRESENTED

Thermal House Kishinev Edition Books

<https://t.me/thermalhouse>

Caffeine Performance

Sugar Benz Show

Trojan Tactics Spirit ---

<https://t.me/trojantactics>

Corina plays with LEDs

Mos Kush

<https://soundcloud.com/darvv1n/lumea-ta>

Ros

DJ Aje

<https://soundcloud.com/djaje>

Music Dump Playlist

<https://t.me/joinchat/Cr0jNBZ4HkvOqRA3GyR7vw>



SALUTĂRI DIN CIOCANA. ПРИВЕТ С ЧЕКАХ. GREETINGS FROM CIOCANA.
POSTCARDS OUT IN STREETS, Ciocana, Chisinau, Republic of Moldova, 2019

SALUTĂRI DIN CIOCANA. ПРИВЕТ С ЧЕКАХ. GREETINGS FROM CIOCANA

Correspondence Postcard from 5th sector of Chisinau, Ciocana.

This postcard was published as result of 1 month living and work experiment in periphery area of Chisinau, Republic of Moldova.

Selection of postcard motives are reflection of sinking in reality of Ciocana [engl. Hammer] with aspects of life there. It is mix of hope, human story, decay, fresh air on hill, isolation, mighty Sun sets, turbo capitalism taking care of all and home for 160 000 citizens.

Postcard design is homage to people sharing in peace one district as well as tribute to East culture Moderna quality designs of 1970s. Writing side of postcard has been left mostly empty for convenience of future users.



Fake Post, Chisinau, Moldavia, 2019

FAKE POST

Alternative spot for writing and drawing postcards established for one day at Food Market garden (Alimentara Natalie), visitors were encouraged to write letters and decorate them together with participants of Oberliht asossiation summer school taking part in Ciocana settlement. Close to 200 letters was produced and later sent to its destinations together with postcard "Greeting from Ciocana".



Glass Interface, Hause Der Statistik, Berlin, 2019

GLASS INTERFACE IN HAUSE DER STATISTICKS, RETHINK OPEN FORM

1 week work in and infiltration of space. As part of "OPEN FORM" project in Hause der Statistik. I attempted to use semi public pavilion of Haus Der Statik as work space. The glass wall used as platform for chalk-marker comments, display of fresh thermal prints and image library created in Lublin and Berlin. Content was gradually reoriented from inside to outside reading position.

<https://open-form-neu-denken.tumblr.com/air>

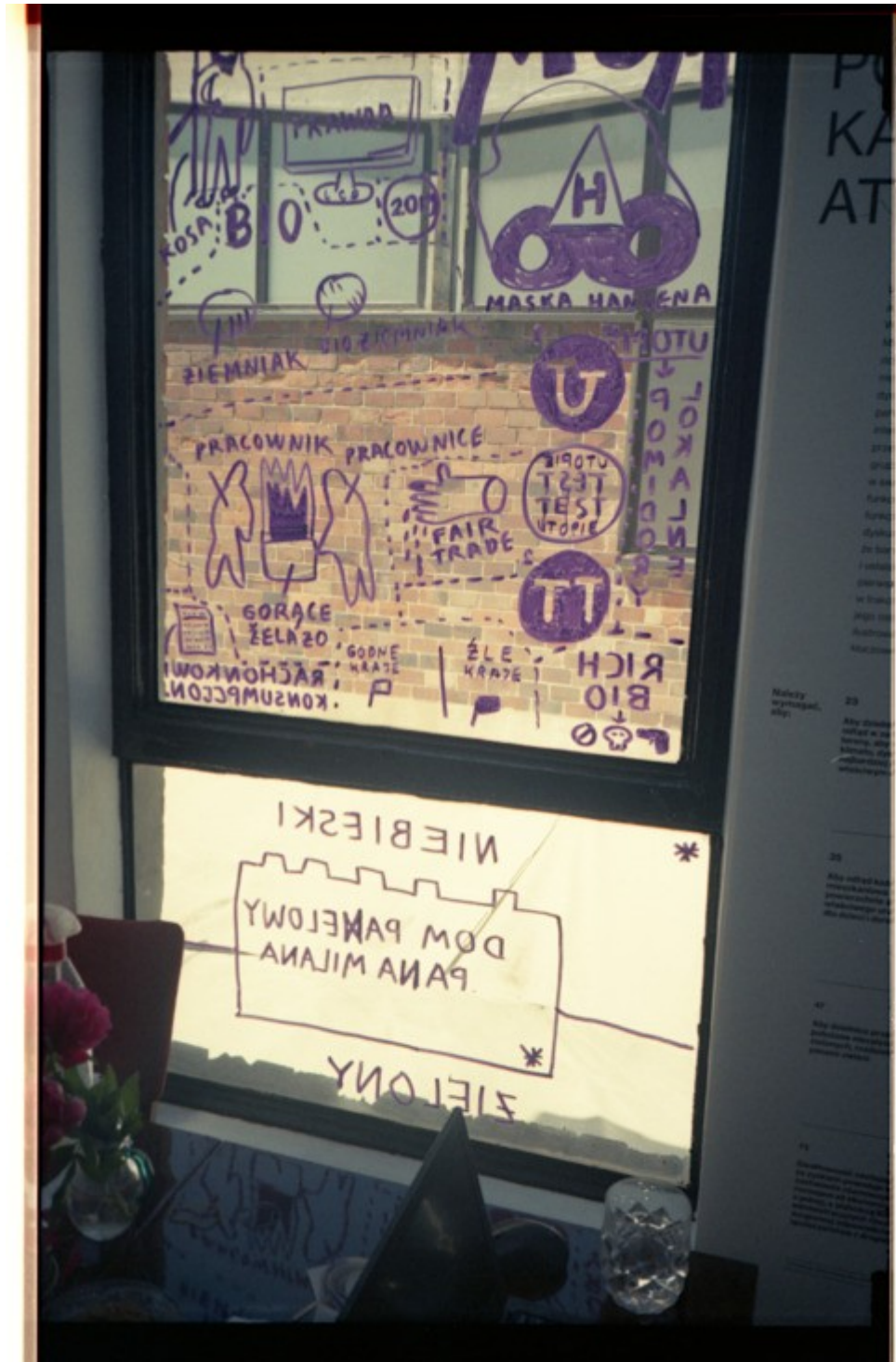

Rachunek za inspekcji, Lublin, Poland, 2019

INSPEKCE LUBLINA

Hotel Huszar becoming environment to adopt transition aesthetics of Socialism to Post-Socialism.
 Local food tested and explored. (Bigos, Zurek, Kapusta, Cholodnik, Borszcz, Salatek, kompot)
 MOM museum and hotel room used as authentic studios to print and produce samizdat publications.
 Inspection of Garden Colony and Datchas there.
 Inspection of MOM Library dedicated to Modernism.
 Inspection of Market and its food and service capacities.
 Window of MOM chalk draw intervention. Violet.
 60 letters sent out with Rachunek za Inspekcji and LSM MOM Postcards.

<https://vimeo.com/413161506>



Jailed Flora in Europe, 2019 ~ now

JAILED FLORA

Topic of urban flora usually co-existing in close proximity of Modernist Architecture.

Colorful and improvised living sculptures existing in plant environments.

Often arranged and maintained by citizens as exemplary initiative maintained value and quality in public space of city.



Colors Activation, 2019

COLORS ACTIVATION

Process of harvesting, storing and dealing with industrial and office use colors cartridges. Process of reuse engineering and recovering capacity of trash produced as and side effect of western world over consumption, consumerism and customer oriented life style. Colors are accumulated and in right moment used and distributed.



3rd Space as Ethical Cultural and Working Platform for Artist. Muzeum Zemstvie, 2019

3rd SPACE

The “**third–place**” is space in–between, not really public, not really private. Just like coffees, bars, collective workshops or street mechanics. They have role of venues where people know they will meet their friends.

The third–place is a place we need in contemporary environment of modern cities. It is a place where we can feel at home without the constraints of the home. Where we can seek other people, people with whom we can debate, and establish a common understanding of reality. Up to the point where those exchanges become an “*art de vivre*”.

DEFINITION OF 3rd SPACE

A neutral ground – Visitors are not tied down to the area financially, politically, legally, or otherwise and are free to come and go as they please.

A leveler (a leveling place) – Third places put no importance on an individual's status in a society. Someone's economic or social status does not matter in a third place, allowing for a sense of commonality among its occupants. There are no prerequisites or requirements that would prevent acceptance or participation in the third place.

The regulars – Third places harbor a number of regulars that help give the space its tone, and help set the mood and characteristics of the area. Regulars to third places also attract newcomers, and are there to help someone new to the space feel welcome and accommodated.

A low profile – Third places are characteristically wholesome. The inside of a third place is without extravagance or grandiosity, and has a homely feel. Third places are never snobby or pretentious, and are accepting of all types of individuals, from several different walks of life.



Hommage to Public Transport Workers, 2019

TICKET

This approximately 196% enlarged Chisinau Trolleybus ticket is homage to passengers, drivers and conductors. They are true travel proletariat and brave heroes and heroin. They challenge every day "Dragon" of futuristic but low capacity transport system.



Hideouts in Modernism, 2018 ~ now

HIDEOUTS IN MODERNISM

Series of attempt of adopting and infiltrating Modernistic structures across Europe. Using those spaces in any possible practical way, according of need of Culture Precariat. Those places becoming shelter, studio, flat theater, discussion space, kitchen, publishing houses, light house and laboratory.

CURRENTLY SCANNED

Praha, Modřany, Larsen–Nielsen, 1986

Chisinau, Dacia Blvd, Vorota Goroda, arch. Skvortsova, 1983

Lublin, MOM, Museum of Settlements, arch. Oskar and Zofia Hansen, 1972

Litvínov, Kolektivní dům, Collective house, arch. Václav Hlinský, 1949

PENDING VISIT

Belgrade, Istočna Kapija Beograda, arch. Vera Ćirković, 1976

Katowice, Superjednostka, arch. Mieczysław Król, 1972

Gdańsk, Falowiec, 1970



Kolxoz, main city market, 8. 3. 2020, Chisinau

KOXOZ COLLECTIVE

Moment of presentation of Postcards production and Samizdat prints at main Flea Market of Chisinau. Work were produced in Pre-Virus time, of Spring 2020.

For visitors we have prepared hot coffee with Cardamom, which has antiseptic and self immunity effect.

This moments was very cheerful and full of understanding.

Next week has been Flea Market area closed due the quarantine measures and it stay close since than.

t.me/deep_kolxoz

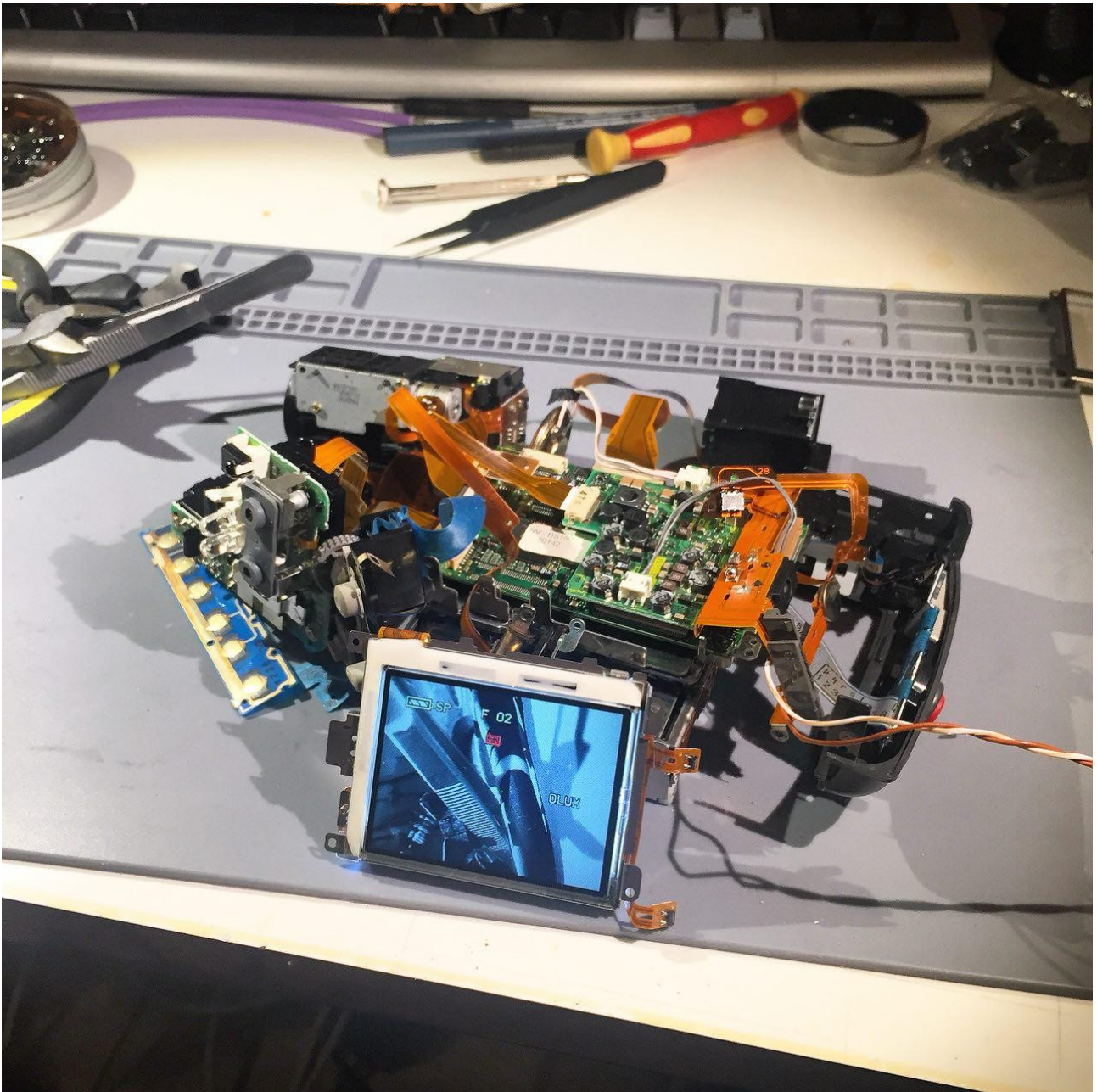

Inversed Electronics, Inversed Camera, 2020

INVERSED ELECTRONICS

Examination of purposes and moral character of an electronic equipment by turning it inside-out.

Electronics world and equipment is getting more and more sophisticated.

I am practicing ritual of humanization of perfect products.

They lose its original form, and reveal more understandable nature.

Destruction in this point is progress in higher value and quality.



Utopie pro kazdy den

future | budoucnost

past | minulost

info

press F11 = beautiful

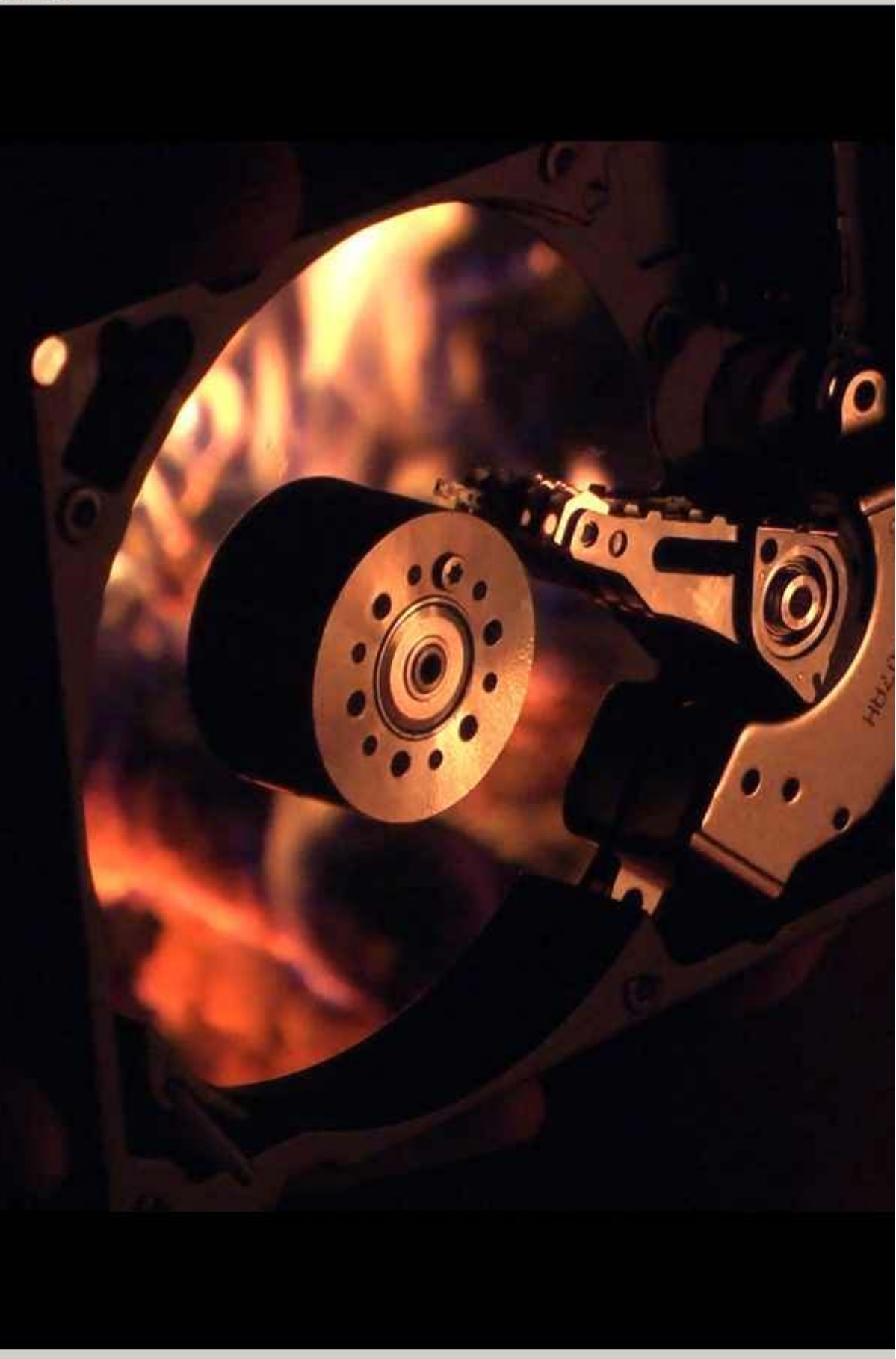



Utopie pro kazdy den

future | budoucnost

past | minulost

info

contact

folio

bio

press F11 = beautiful

Viktor Vejvoda

Made in Czechoslovakia

LINKS

utopia.comlu.com
vimeo.com/user4966699
homeiswheretrashis.tumblr.com
amsterdaminiso.tumblr.com
trojantactics.tumblr.com

EDUCATION

2009 — 2015 M. A. at Academy of Fine Arts in Prague, Studio New Media I.
2006 — 2009 DiS. at Tercial graphic school Hellichova, photography

PUBLICATIONS

Via Baltica, with Aleksí Cavaillez, publ. Noir sur Blanc, Paris, 2006
<http://utopia.comlu.com/index.php?/tada/via-baltica/>
East:West, 1:0, 2009 <http://utopia.comlu.com/index.php?/tada/east-beats-west-10/>
Drevo, 2011 (<http://utopia.comlu.com/index.php?/drevoleswood/>)
PPP, Poetická politická pohádka, 2012 (<http://utopia.comlu.com/index.php?/ppp/>)
Mastné stánky, 2012
Kiosk, 2013 (<http://utopia.comlu.com/index.php?/publikace-kiosk/>)
LOS, with Markéta Mrácková and Bára Šimonová, 2015, (cosa.cz)
TRASH FRUITS, Trojan Tactics studio, Amsterdam, 2016 (trojantactics.tumblr.com)
TT MENU FOR OPENHOUSE, Trojan Tactics studio, Berlin, 2016
TRUE IS; WHERE TRASH IS., set of 32 postcards, Berlin, 2017 (homeiswheretrashis.tumblr.com)

KEYWORDS

emancipation effect of repair, author vs. Customer, sharing of knowledge, inter-community education, working and cooperating circle of individuals rather than pedagogue-centered model role of artist as a occupation strictly connected to society and its issues and perspective, pay back to cultural heritage by performing uneconomic activity for capital-realism, depressive printer, 100 % eco printer, reverse engineering, repairing is way of knowing things we use — parallel to open source programming, irrational repairs of rational objects, modern shamanic, drug suiting repairs is caffeine, garbology, chrematology, trash, electronics, hope, coop, death of individualism, anti-ego, HY help yourself,



Utopie pro kazdy den

future | budoucnost

- [TT Trojan Tactic](#)
- [Studio](#)
- [TRUE IS WHERE](#)
- [TRASH IS](#)
- [25 Forgotten Buildings](#)
- [bar at Great Wall](#)
- [Factory for the Absolute](#)
- [Dirty paintings](#)
- [Hair Internat](#)
- [Individualised Food](#)
- [Weapons](#)
- [ISO Cafe](#)
- [Potatoe Season](#)
- [Oslavna rec. Speech](#)
- [Periscope out of scrap](#)
- [CCTV cameras](#)
- [Repair kiosk in Amsterdam](#)
- [Freedom free-doom](#)
- [solidarnosc clip](#)
- [IAU in ZK/U](#)
- [Kiosk v penzionu](#)
- [odlozeneho umeri](#)
- [Peripheral knowledge](#)
- [INI meetings](#)
- [LOS Legenda o sidlisti](#)
- [Opravy v Ceskem Krumlovi](#)
- [Krumlovi](#)
- [Nocni Cesky Krumlov](#)
- [EFP 2014](#)
- [Semestr SVU 2014](#)
- [Druzstevni publikace](#)
- [komiksu](#)
- [Navrh](#)
- [Ceskoslovenskeho pavilonu](#)
- [Silna kava v Berlino](#)
- [Zavarena mena](#)
- [Subconscious educative manual](#)
- [Tribute to instructions](#)
- [Waveform. Video to Voits](#)
- [Modely pro \(Dis\)harmon](#)
- [Kiosk pro A la recherche de la boheme perdue](#)
- [Gallery Ducato](#)

past | minulost

- [Pruhledna tajemství](#)
- [Transparent Secret](#)
- [publikace KIOSK](#)

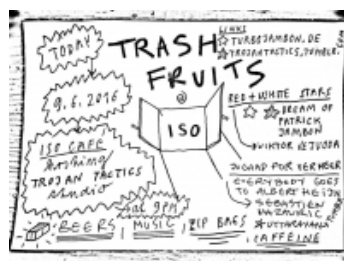

TT Trojan Tactics

Because 3 is more than 1, TT.

Because coop and collective work is more joy than ego-maniac production, TT.

Because only on Horse you can ride speedy into Application, TT.

trojantactics.tumblr.com

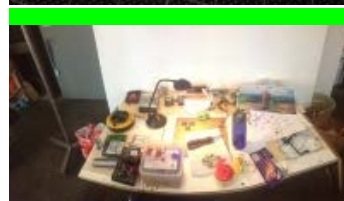



Text



Utopie pro kazdy den

future | budoucnost

- IT Trojan Tactic
- Studio
- TRUE IS: WHERE TRASH IS.
- 25 Forgotten Buildings
- bar at Great Wall
- Factory for the Absolute
- Dirty paintings
- Hair Internat
- Individualised Food
- Weapons
- ISO Cafe
- Potatoe Season
- Oslavna rec. Speech
- Periscope out of scrap
- CCTV cameras
- Repair kiosk in Amsterdam
- Freedom free-doom
- solidarnosc clip
- IAU in ZK/U
- Kiosk v penzionu
- odlozeneho umeri
- Peripheral knowledge
- INI meetings
- LOS Legenda o sidlisti
- Opravy v Ceskem
- Krumlovi
- Nocni Cesky Krumlov
- EEP 2014
- Semestr SVU 2014
- Druzstevni publikace
- komiksu
- Navrh
- Ceskoslovenskeho pavilonu
- Silna kava v Berlino
- Zavarena mena
- Subconscious educative manual
- Tribute to instructions
- Waveform. Video to
- Volts
- Modely pro
- (Dis)harmon
- Kiosk pro A la
- recherche de la boheme
- perdue
- Gallery Ducato

past | minulost

- Prhledna tajemstvi
- Transparent Secret
- publikace KIOSK

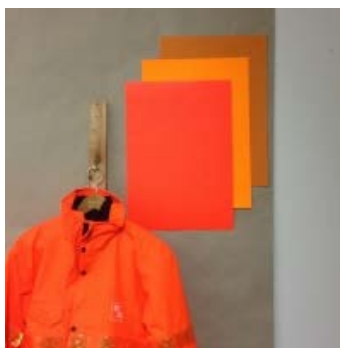

TRUE IS; WHERE TRASH IS.

6 months displacement at Berlin sanitation company (BSR) and roofed by ZK/U Berlin.

homeiswheretrashis.tumblr.com

POSTCARDS

The postcards have been created during six month (July–December, 2016) Artist Displacement project at BSR, Berlin. They are my personal reflection on world of sanitation within the company I was able to enter.

CONTENT

28 postcards, 4 interactive postcards, glitter





DISPLACED
VIKTOR VEJVODA
ZEKU SIEMENSSTRASSE 27
BERLIN-MOABIT, GERMANY

1 0 5 5 1



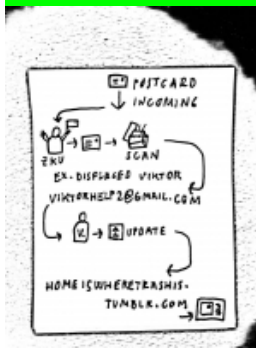

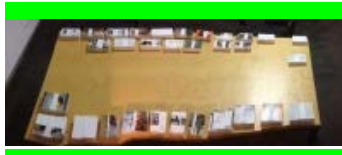



Utopie pro kazdy den

future | budoucnost

- [IT Trojan Tactic](#)
- [Studio](#)
- [TRUE IS: WHERE](#)
- [TRASH IS:](#)
- [25 Forgotten Buildings](#)
- [bar at Great Wall](#)
- [Factory for the Absolute](#)
- [Dirty paintings](#)
- [Hair Internat](#)
- [Individualised Food](#)
- [Weapons](#)
- [ISO Cafe](#)
- [Potatoe Season](#)
- [Oslama rec. Speech](#)
- [Periscope out of scrap](#)
- [CCTV cameras](#)
- [Repair kiosk in](#)
- [Amsterdam](#)
- [Freedom free-doom](#)
- [solidarnosc clip](#)
- [IAU in ZK/U](#)
- [Kiosk v penzionu](#)
- [odlozeneho umeri](#)
- [Peripheral knowledge](#)
- [INI meetings](#)
- [LOS Legenda o sidlisti](#)
- [Opravy v Ceskem](#)
- [Krumlovi](#)
- [Nocni Cesky Krumlov](#)
- [KEP_2014](#)
- [Semestr SVU 2014](#)
- [Druzstevni publikace](#)
- [komiksu](#)
- [Navrh](#)
- [Ceskoslovenskeho](#)
- [pavilonu](#)
- [Silna kava v Berlina](#)
- [Zavarena mena](#)
- [Subconscious educative](#)
- [manua](#)
- [Tribute to instructions](#)
- [Waveform. Video to](#)
- [Volts](#)
- [Modely pro](#)
- [\(Dis\)harmon](#)
- [Kiosk pro A la](#)
- [recherche de la boheme](#)
- [perdue](#)
- [Gallery Ducate](#)

past | minulost

[Prhledna tajemstvi](#)



Text

Participation on project of Cultural Cooperative **cosa.cz**
Gottfried Müller – 25 Forgotten Buildings

A Czech-German publication of 25 architectural adventure stories – portraits of forgotten houses, written by German visual artist Gottfried Müller. Stories tell about troubles of building process, strangeness of builders and the whims of investors.

cosa.cz/kniha-book

Gottfried Müller – 25 Forgotten Buildings

German originals „Schwermut und Abenteuer des Hausbaus: 24 Portraits verlorener Gebäude“

Translation Mirko Baum

Publishers Markéta Mrácková, Barbora Šimonová, Cultural Cooperative cosa.cz 2016

GD Viktor Vejvoda

Czech editor: Sona Ryndová

Print run 1000 copies

64 pages

ISBN **978-80-270-0646-5**

Project supported by the Czech-German Future Fund, the Czech Architecture Foundation, and the Art-Now Fund.



Utopie pro kazdy den

future | budoucnost

- IT Trojan Tactic
- Studio
- TRUE IS: WHERE
- TRASH IS:
- 25 Forgotten Buildings
- bar at Great Wall
- Factory for the Absolute
- Dirty paintings
- Hair Internat
- Individualised Food
- Weapons
- ISO Cafe
- Potatoe Season
- Oslavna rec. Speech
- Periscope out of scrap
- CCTV cameras
- Repair kiosk in
- Amsterdam
- Freedom free-doom
- solidarnosc clip
- IAU in ZK/U
- Kiosk v penzionu
- odlozeneho umeri
- Peripheral knowledge
- INI meetings
- LOS Legenda o sidlisti
- Opravy v Ceskem
- Krumlov
- Nocni Cesky Krumlov
- EEP 2014
- Semestr SVU 2014
- Druzstevni publikace
- komiksu
- Navrh
- Ceskoslovenskeho
- pavilonu
- Silna kava v Berlina
- Zavarna mena
- Subconscious educative
- manua
- Tribute to instructions
- Waveform. Video to
- Volts
- Modely pro
- (Dis)harmon
- Kiosk pro A la
- recherche de la boheme
- perdue
- Gallery Ducate

past | minulost

Pruhledna tajemstvi |



Text

At Great Wall

- No profit model of existence.
- Free Glitter
- Free Re-Cycled Drinks
- Free Cigarettes
- Free LP's of Jauf

photo Bo Wang, Katarina Jancovicova



Factory for the Absolute > Tovarna na absolutno

Original and self made Apple MacBookPro screw. Rais and creat. Humanity is in DIY hands. Hands not Robots! Lets improvise out of troubles.

Text

Utopie pro kazdy den

future | budoucnost

- IT Trojan Tactic
- Studio
- TRUE IS: WHERE
- TRASH IS.
- 25 Forgotten Buildings
- bar at Great Wall
- Factory for the Absolute
- Dirty paintings
- Hair Internat
- Individualised Food
- Weapons
- ISO Cafe
- Potatoe Season
- Oslavna rec. Speech
- Periscope out of scrap
- CCTV cameras
- Repair kiosk in
- Amsterdam
- Freedom free-doom
- solidarnosc clip
- IAU in ZK/U
- Kiosk v penzionu
- odlozeneho umeri
- Peripheral knowledges
- INI meetings
- LOS Legenda o sidlisti
- Opravy v Ceskem
- Krumlovi
- Nočni Cesky Krumlov
- KEP 2014
- Semestr SVU 2014
- Druzstevni publikace
- komiksu
- Navrh
- Ceskoslovenskeho
- pavilonu
- Silna kava v Berlina
- Zavarena mena
- Subconscious educative
- manua
- Tribute to instructions
- Waveform. Video to
- Volts
- Modely pro
- (Dis)harmon
- Kiosk pro A la
- recherche de la boheme
- perdue
- Gallery Ducate

past | minulost

- Prhledna tajemstvi |



Utopie pro kazdy den

future | budoucnost

- IT Trojan Tactic
- Studio
- TRUE IS: WHERE
- TRASH IS:
- 25 Forgotten Buildings
- bar at Great Wall
- Factory for the Absolute
- Dirty paintings
- Hair Internat
- Individualised Food
- Weapons
- ISO Cafe
- Potatoe Season
- Oslavna rec. Speech
- Periscope out of scrap
- CCTV cameras
- Repair kiosk in
- Amsterdam
- Freedom free-doom
- solidarnosc clip
- IAU in ZK/U
- Kiosk v penzionu
- odlozeneho umeri
- Peripheral knowledge
- INI meetings
- LOS Legenda o sidlisti
- Opravy v Ceskem
- Krumlovi
- Nocni Cesky Krumlov
- EEP 2014
- Semestr SVU 2014
- Druzstevni publikace
- komiksu
- Navrh
- Ceskoslovenskeho
- pavilonu
- Silna kava v Berlino
- Zavarena mena
- Subconscious educative
- manua
- Tribute to instructions
- Waveform. Video to
- Volts
- Modely pro
- (Dis)harmon
- Kiosk pro A la
- recherche de la boheme
- perdue
- Gallery Ducato

past | minulost

- Prhledna tajemstvi |
- Transparent Secret
- publikace KIOSK

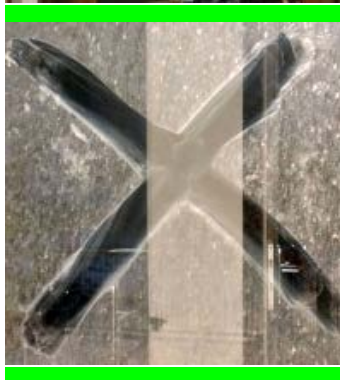

Dirty Paintings >>> Crosses and Squares

Paintings into dirt of institutions Windows. Making transparent the glass but also institution itself. Cleaning is one of few activities for which are not individuals prosecuted. Dirty is mostly ignored and untended capacity. Aggressive cleaning strategy is highlighting contrast between clean and dirty.



Text



Utopie pro kazdy den

future | budoucnost

- IT Trojan Tactic
- Studio
- TRUE IS: WHERE
- TRASH IS:
- 25 Forgotten Buildings
- bar at Great Wall
- Factory for the Absolute
- Dirty paintings
- Hair Internet
- Individualised Food
- Weapons
- ISO Cafe
- Potatoe Season
- Oslavna rec. Speech
- Periscope out of scrap
- CCTV cameras
- Repair kiosk in
- Amsterdam
- Freedom free-doom
- solidarnosc clip
- IAU in ZK/U
- Kiosk v penzionu
- odlozeneho umeri
- Peripheral knowledge
- INI meetings
- LOS Legenda o sidlisti
- Opravy v Ceskem
- Krumlovi
- Nocni Cesky Krumlov
- EEP-2014
- Semestr SVU 2014
- Druzstevni publikace
- komiksu
- Navrh
- Ceskoslovenskeho
- pavilonu
- Silna kava v Berlina
- Zavarena mena
- Subconscious educative
- manua
- Tribute to instructions
- Waveform. Video to
- Volts
- Modely pro
- (Dis)harmon
- Kiosk pro A la
- recherche de la boheme
- perdue
- Gallery Ducato

past | minulost

- Pruhledna tajemstvi |
- Transparent Secret
- publikace KIOSK



HAIR INTERNET

Hair Internet ~ continual manifesto of self education and pro-community knowledge and machinery sharing. Research about different styles, matter and typology of hair inside Art and Culture micro-society. Observing of reactions of Hair Internet Participants, once their head is being clipped.

list of engaged hair

- Czechoslovak
- French
- Galician
- South African
- German
- Turkish
- Korean
- Austrian
- Chilean
- Australian
- Japanese
- Dutch

...

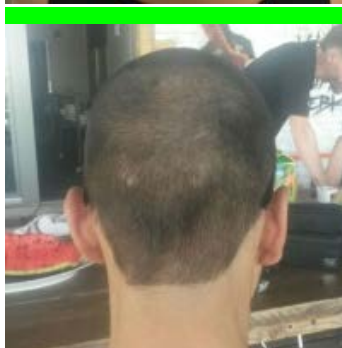
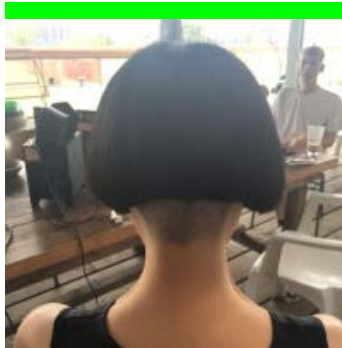
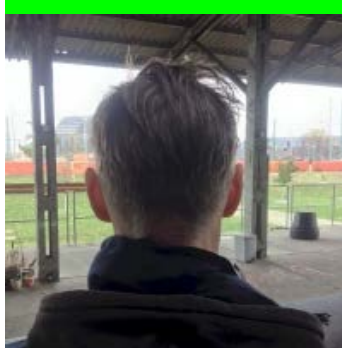
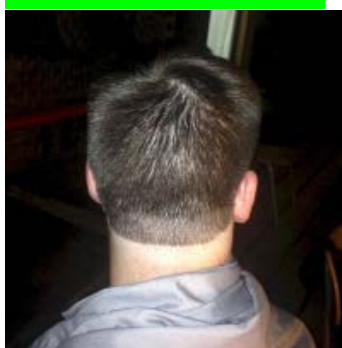

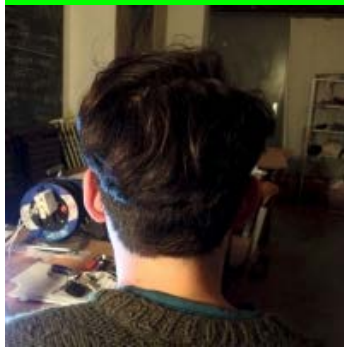



Text



Utopie pro kazdy den

future | budoucnost

- IT Trojan Tactic
- Studio
- TRUE IS WHERE
- TRASH IS
- 25 Forgotten Buildings
- bar at Great Wall
- Factory for the Absolute
- Dirty paintings
- Hair Internat
- Individualised Food
- Weapons
- ISO Cafe
- Potatoe Season
- Oslavna rec. Speech
- Periscope out of scrap
- CCTV cameras
- Repair kiosk in
- Amsterdam
- Freedom free-doom
- solidarnosc clip
- IAU in ZK/U
- Kiosk v penzionu
- odlozeneho umeri
- Peripheral knowledge
- INI meetings
- LOS Legenda o sidlisti
- Opravy v Ceskem
- Krumlovi
- Nozni Cesky Krumlov
- REP. 2014
- Semestr SVU 2014
- Druzstevni publikace
- komiksu
- Navrh
- Ceskoslovenskeho
- pavilonu
- Silna kava v Berlino
- Zavarena mena
- Subconscious educative
- manua
- Tribute to instructions
- Waveform. Video to
- Volts
- Modely pro
- (Dis)harmonii
- Kiosk pro A la
- recherche de la boheme
- perdue
- Gallery Ducato

past | minulost

- Pruhledna tajemstvi |
- Transparent Secret
- publikace KIOSK

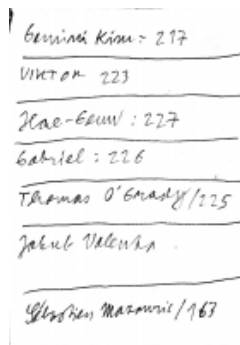

Hand signed communal kitchen cutlery

Actual topics, resident names and statements.
 Some of pieces keep circulating in kitchen system for 7 months.
 Some has been transported out of Europe.

Numbered inmates/residents have strong resemblance to any kind of authoritarian (and worst system) which immediately starts to operate on bases of registration individuals and putting them into system of archive. Closest example we can find in neighbor institution of ZK/U (Center for Architecture and Urbanism) in Moabit Prison. Where under changing regimes were people numbered as well.

While having dinner in communal kitchen, residents of ZK/U has chance to investigate about numbers their charing fate, but also about destiny and systems of organization they are enlisted in.

Individuals without assigned number were presented with First Name.

Justizvollzugsanstalt Moabit

built 1877-1882
 architects Heinricha Hermann and August Busse

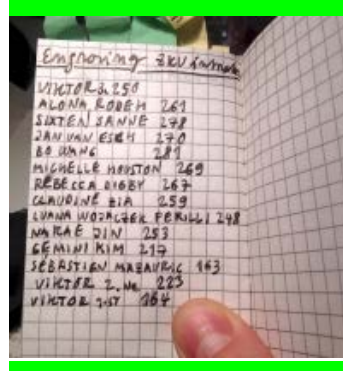

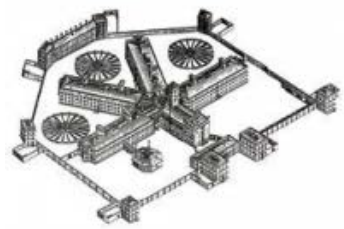
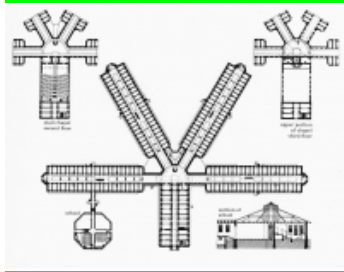

Text



Utopie pro kazdy den

future | budoucnost

- [IT Trojan Tactics](#)
- [Studio](#)
- [TRUE IS WHERE](#)
- [TRASH IS](#)
- [25 Forgotten Buildings](#)
- [bar at Great Wall](#)
- [Factory for the Absolute](#)
- [Dirty paintings](#)
- [Hair Internat](#)
- [Individualised Food](#)
- [Weapons](#)
- [ISO Cafe](#)
- [Potatoe Season](#)
- [Oslavna rec. Speech](#)
- [Periscope out of scrap](#)
- [CCTV cameras](#)
- [Repair kiosk in Amsterdam](#)
- [Freedom free-doom](#)
- [solidarnosc clip](#)
- [IAU in ZK/U](#)
- [Kiosk v penzionu odlozeneho umeri](#)
- [Peripheral knowledge](#)
- [INI meetings](#)
- [LOS Legenda o sidlisti](#)
- [Opravy v Ceskem Krumlovi](#)
- [Nocni Cesky Krumlov](#)
- [EFP 2014](#)
- [Semestr SVU 2014](#)
- [Druzstevni publikace](#)
- [komiks](#)
- [Navrh](#)
- [Ceskoslovenskeho pavilonu](#)
- [Silna kava v Berlino](#)
- [Zavarena mena](#)
- [Subconscious educative manual](#)
- [Tribute to instructions](#)
- [Waveform. Video to volts](#)
- [Modely pro \(Dis\)harmonii](#)
- [Kiosk pro A la recherche de la boheme perdue](#)
- [Gallery Ducato](#)

past | minulost

- [Pruhledna tajemstvi](#)
- [Transparent Secret](#)
- [publikace KIOSK](#)

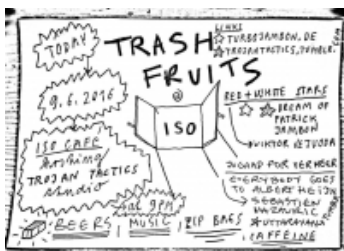

ISO Café in Amsterdam at Java Island

3 months Art residency in metal box of ISO container at Java Island. Repairs, caffeine, rain, wind, sun and improvisations. Also chance to people. Supported by Elia organization and by enthusiasts.

ISO

An intermodal container is a large standardized shipping container, designed and built for intermodal freight...

Diary about Art residency in Camp (FabCamp) by Elia organization, Europe by People programme and Pakhuis De Zwijger, Amsterdam.

amsterdaminiso.tumblr.com







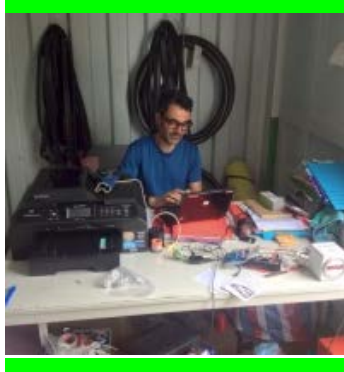
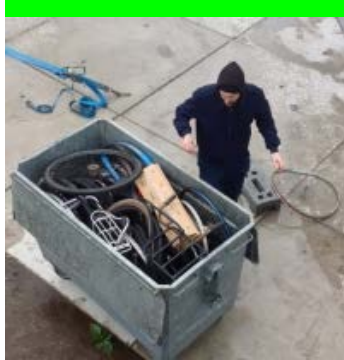



Text



Utopie pro kazdy den

future | budoucnost

- IT Trojan Tactic
- Studio
- TRUE IS WHERE
- TRASH IS
- 25 Forgotten Buildings
- bar at Great Wall
- Factory for the Absolute
- Dirty paintings
- Hair Internat
- Individualised Food
- Weapons
- ISO Cafe
- Potatoe Season
- Oslavna rec. Speech
- Periscope out of scrap
- CCTV cameras
- Repair kiosk in
- Amsterdam
- Freedom free-doom
- solidarnosc clip
- IAU in ZK/U
- Kiosk v penzionu
- odlozeneho umeri
- Peripheral knowledge
- INI meetings
- LOS Legenda o sidlisti
- opravy v Ceskem
- Krumlovi
- Nočni Cesky Krumlov
- KEP-2014
- Semestr SVU 2014
- Druzstevni publikace
- komiksu
- Navrh
- Ceskoslovenskeho
- pavilonu
- Silna kava v Berlino
- Zavarena mena
- Subconscious educative
- manual
- Tribute to instructions
- Waveform. Video to
- Volts
- Modely pro
- (Dis)harmon
- Kiosk pro A la
- recherche de la boheme
- perdue
- Gallery Ducato

past | minulost

- Pruhledna tajemství |
- Transparent Secret
- publikace KIOSK



Potatoe Season

Coop Art work with Thomas O'Grady.

Piece considering of the cooking, ingredients, transmission, critical acknowledgement of the 50€, and the attachment to personal history and food.

To full fill communal duty to cook for 20-30 persons for 50€, we have chose emotionally and politically charged recipes and selection of 'poor' cousin mostly rooting from Celtic, Slavic and Irish tradition.

MENU

Haruki Murakami - Cucumber, dying man recipe

Chopped Cucumber, soy sauce. (text 1)

Saddam Hussein Black Tears over Baghdad coffee

Strong black coffee, cardamom flavor (text 2)

Inquisition-Colonial Baked Potatoes with Onion

Baked potatoes southern Peru 8000 BC origin.

Boiled Welfare potatoes Fruits of fields of Ireland and Czechoslovakia

Boiled potatoes, served from one pot. Salt, butter, buttermilk, quark.

Traditional Calories Pork Fat Spread

Fat spread on bread, salt, onion.

Both Korea's rice Tea and Tuna Flavored oil

Tea from fried rice.

Oil to flavor your dish taken from tuna.

Tuna can flavor your oil 2 or 3 times.

50cents Apple Juice

Apple puree mixed with cold water 1:1 or 1:2 (water) ratio.

Price of 1.5 liter of such juice is 50 Cents.

Northern Working Class Food.

Yorkshire Pudding

Flour, Eggs, Water. 2016.

Named after the largest county in England. This northern food has been eaten by workers for generations. It is typically eaten with potatoes and gravy. Sometimes people eat them with jam.

Mashed Potatoes.

Potatoes, Butter, Salt. 2016.

Mashed potatoes can be eaten with butter and in Ireland are often mixed with cabbage. Any spare mashed potato that is left over (from this evenings meal) will be refrigerated and then made in to potato cakes and lightly fried the next day - which is typically done in Irish homes.

Gravy.

Vegetable fats, Meat fats, Water.

Thick gravy sauce which is poured over the Mashed Potatoes and Yorkshire Puddings.



Text



Utopie pro kazdy den

future | budoucnost

- IT Trojan Tactic
- Studio
- TRUE IS: WHERE
- TRASH IS:
- 25 Forgotten Buildings
- bar at 'Great Wall'
- factory for the Absolut
- Dirty paintings
- Hair Internat
- Individualised Food
- Weapons
- ISO Cafe
- Potatoe Season
- Oslavna rec... Speech
- Periscope out of scrap
- CCTV cameras
- Repair kiosk in
- Amsterdam
- Freedom free-doom
- solidarnosc clip
- IAU in ZK/U
- Kiosk v penzionu
- odlozeneho umeri
- Peripheral knowledge
- INI meetings
- LOS Legenda o sidlisti
- Opravy v Ceskem
- Krumlovi
- Nozni Cesky Krumlov
- EEP 2014
- Semestr SVU 2014
- Druzstevni publikac
- komiksu
- Navrh
- Ceskoslovenskeho
- pavilonu
- Silna kava v Berlina
- Zavarena mena
- Subconscious educative
- manua
- Tribute to instructions
- Waveform Video to
- Voits
- Modely pro
- (Dis)harmon
- Kiosk pro A la
- recherche de la boheme
- perdue
- Gallery Ducato

past | minulost

Pruhledna tajemstvi

LONG LIVE 장수하길
[EANN-SU-MA-JE-JO]
GEMINI 지미니 [GEE-MIN-IN]
I WISH HIM LUCK 행운을 빌어
[HE-NONJ-IKYEB-PARAE]
~~IN THE CAREER~~
AND SUCCESS IN ART
예술 성공을!
[JE-ZULO-JONGON-MHE]
LET'S GET DRUNKEN CHEE
치합! [CIA-JE-A]
LIKE BUSINESSMAN IN SEOUL ST.
서울에서 인싸는 직장인이다
[SOUL-BA-EOL-ANE-IN-N]

DI-CA-(N-ZORONG)
FIRE 불 켜지겠다!!
[PUL-DEI-LO-PARBYJO]
THANK YOU 고맙
[KO-MA-WO]
CHEERS 음 [KOMBE]



Text

Oslavna rec -- Speech

Celebratory speech for during festive occasion.

Korean voice: Viktor Vejvoda

English voice: Seo Hae-Geun

Oslavna rec pri slavnostni priležitosti.

Korejska cast textu: Viktor

Anglictina: Hae-Geun



Utopie pro kazdy den

future | budoucnost

- IT Trojan Tactic
- Studio
- TRUE IS: WHERE
- TRASH IS:
- 25 Forgotten Buildings
- bar at Great Wall
- Factory for the Absolute
- Dirty paintings
- Hair Internat
- Individualised Food
- Weapons
- ISO Cafe
- Potatoe Season
- Oslavna rec. Speech
- Periscope out of scrap
- CCTV cameras
- Repair kiosk in
- Amsterdam
- Freedom free-doom
- solidarnosc clip
- IAU in ZK/U
- Kiosk v penzionu
- odlozeneho umeri
- Peripheral knowledge
- INI meetings
- LOS Legenda o sidlisti
- Opravy v Ceskem
- Krumlovi
- Nocni Cesky Krumlov
- EEP 2014
- Semestr SVU 2014
- Druzstevni publikace
- komiksu
- Navrh
- Ceskoslovenskeho
- pavilonu
- Silna kava v Berlino
- Zavarena mena
- Subconscious educative
- manua
- Tribute to instructions
- Waveform. Video to
- Volts
- Modely pro
- (Dis)harmon
- Kiosk pro A la
- recherche de la boheme
- perdue
- Gallery Ducato

past | minulost

- Pruhledna tajemstvi |
- Transparent Secret
- publikace KIOSK

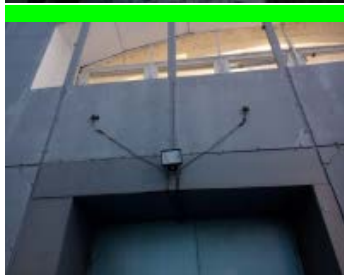
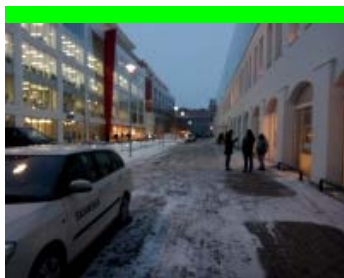
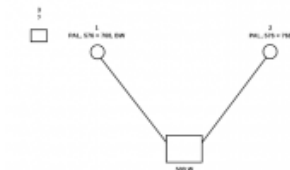

Text

FILTER HARDWORKING camera 1
PUNCTUALLITY TDI camera 2

Karlin studios, Ten dum sem nepatri ~ Karlin Adios

CCTV cameras no. 1 and 2 are refurbished from an electronic equipment waste yard. In the past the role of these Cameras was surveillance and protection of Property. Camera no. 3 has this function, providing security surveillance of the area.

At present in cameras second life after resurgence, the cameras have an ambivalent role. Supervising Surveillance and revealing its perspective. Devotedly looking on smoking or in park chilling capitalism.

Pair of cameras is the symbolic periscope of the studios. Giving opportunity to be interested in the others, out there, before last sink. And opportunity to check the direction of water flow.

foto~ -JV-



Utopie pro kazdy den

future | budoucnost

- [IT Trojan Tactic](#)
- [Studio](#)
- [TRUE IS: WHERE](#)
- [TRASH IS:](#)
- [25 Forgotten Buildings](#)
- [bar at Great Wall](#)
- [Factory for the Absolute](#)
- [Dirty paintings](#)
- [Hair Internat](#)
- [Individualised Food](#)
- [Weapons](#)
- [ISO Cafe](#)
- [Potatoe Season](#)
- [Oslavna rec. Speech](#)
- [Periscope out of scrap](#)
- [CCTV cameras](#)
- [Repair kiosk in Amsterdam](#)
- [Freedom free-doom](#)
- [solidarnosc clip](#)
- [IAU in ZK/U](#)
- [Kiosk v penzionu](#)
- [odlozeneho umeri](#)
- [Peripheral knowledges](#)
- [INI meetings](#)
- [LOS Legenda o sidlisti](#)
- [Opravy v Ceskem](#)
- [Krumlovi](#)
- [Nocni Cesky Krumlov](#)
- [KEP_2014](#)
- [Semestr SVU 2014](#)
- [Druzstevni publikace](#)
- [komiksu](#)
- [Navrh](#)
- [Ceskoslovenskeho pavilonu](#)
- [Silna kava v Berlino](#)
- [Zavarena mena](#)
- [Subconscious educative manual](#)
- [Tribute to instructions](#)
- [Waveform. Video to](#)
- [Volts](#)
- [Modely pro](#)
- [\(Dis\)harmon](#)
- [Kiosk pro A la](#)
- [recherche de la boheme perdue](#)
- [Gallery Ducato](#)

past | minulost

- [Pruhledna tajemstvi](#)
- [Transparent Secret](#)
- [publikace KIOSK](#)



CAFFEINE KNOWLEDGES

Experiment to bring the idea of [Peripheral knowledges](#) into exhibition space of Westergasfabriek. Together with application of idea of social interactions are powered by caffeine. (ref. [Strong coffee in Berlin](#))

[Flia. New Now page](#)

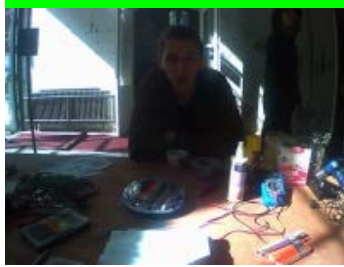

Text



Utopie pro kazdy den

future | budoucnost

- [IT Trojan Tactic Studio](#)
- [TRUE IS WHERE TRASH IS](#)
- [25 Forgotten Buildings](#)
- [bar at Great Wall](#)
- [Factory for the Absolute](#)
- [Dirty paintings](#)
- [Hair Internat](#)
- [Individualised Food](#)
- [Weapons](#)
- [ISO Cafe](#)
- [Potatoe Season](#)
- [Obama rec. Speech](#)
- [Periscope out of scrap](#)
- [CCTV cameras](#)
- [Repair kiosk in Amsterdam](#)
- [Freedom free-doom](#)
- [solidarnosc clip](#)
- [IAU in ZK/U](#)
- [Kiosk v penzionu odlozeneho umeri](#)
- [Peripheral knowledge](#)
- [INI meeting](#)
- [LOS Legenda o sidlisti](#)
- [Opravy v Ceskem Krumlovi](#)
- [Nocni Cesky Krumlov](#)
- [EFP 2014](#)
- [Semestr SVU 2014](#)
- [Druzstevni publikace komiksu](#)
- [Navrh](#)
- [Ceskoslovenskeho pavilonu](#)
- [Silna kava v Berlino](#)
- [Zavarena mena](#)
- [Subconscious educative manual](#)
- [Tribute to instructions](#)
- [Waveform Video to Volts](#)
- [Modely pro \(Dis\)harmonii](#)
- [Kiosk pro A la recherche de la boheme perdue](#)
- [Gallery Ducato](#)

past | minulost

- [Prhledna tajemstvi | Transparent Secret publikace KIOSK](#)



Institute for Art and Urbanism inside Zentrum fur Kunst und Urbanistik

Positive and constructive subversion of institution.

TOPICS

Subversive Peripheries

Kiosk / Desk with Viktor and his Periphery Manifesto.

Possibility of small repairs or destructions.

Visitors are welcomed to bring their own malfunctioning laptop batteries, and ways of re-use of them will be presented.

Budget tool set for basic repairs not exceeding investment of 2 Euro will be shown at place.

Open studio with possibilities of print, scan and chat. Machines saved from trash.

Recovering materials from "Kopi" studios and installing them back to circle of function. (together with Sebastien Mazaauric and Gustavo Sanroman)

Creative CCTV without authority together with Jakub Valenta [CCTV ZK/U](#)

projects sleeps, waiting for re-born.

Bicycles repairs and modifications.

Food sentenced for sacking recirculation. (s. c. Calories Diving)

Attempt to find Andreas Schweda.

Exploration of ZK/U hidden underworld.

Trying to connect Berlin and Prague creative circles together by inviting them to Berlin.

Raspberry Pi 1+2 experiments in semi-public function.

ZK/U, Berlin

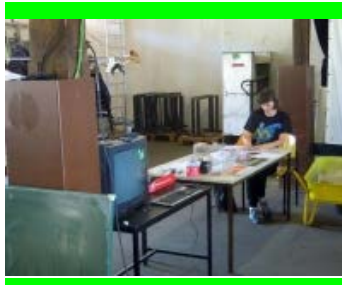



Text



Utopie pro kazdy den

future | budoucnost

- IT Trojan Tactic
- Studio
- TRUE IS: WHERE
- TRASH IS:
- 25 Forgotten Buildings
- bar at Great Wall
- Factory for the Absolute
- Dirty paintings
- Hair Interna
- Individualised Food
- Weapons
- ISO Cafe
- Potatoe Season
- Oslavna rec. Speech
- Periscope out of scrap
- CCTV cameras
- Repair kiosk in Amsterdam
- Freedom free-doom
- solidarnosc clip
- IAU in ZK/U
- Kiosk v penzionu odlozeneho umeri
- Peripheral knowledge
- INI meeting
- LOS Legenda o sidlisti
- Opravy v Ceskem
- Krumlovi
- Nocni Cesky Krumlov
- EEP 2014
- Semestr SVU 2014
- Druzstevni publikace
- komiksu
- Navrh
- Ceskoslovenskeho pavilonu
- Silna kava v Berlino
- Zavarena mena
- Subconscious educative manual
- Tribute to instructions
- Waveform. Video to
- Volts
- Modely pro
- (Dis)harmon
- Kiosk pro A la
- recherche de la boheme perdue
- Gallery Ducato

past | minulost

- Pruhledna tajemstvi |
- Transparent Secret
- publikace KIOSK



KIOSK V PENZIONU ODLOZENEGO UMENI

Kiosk jako protivaha zamku Trebesice

Kiosk se stal zahradnim pavilonkem.

Kiosk as a counterweight for Chateau Trebesice

Kiosk has become Garden Pavilion.

BONUS: seversko-lichtenstejnske fondy a mini-mys.



Text



Utopie pro kazdy den

future | budoucnost

- IT Trojan Tactic
- Studio
- TRUE IS: WHERE
- TRASH IS:
- 25 Forgotten Buildings
- bar at Great Wall
- Factory for the Absolute
- Dirty paintings
- Hair Interna
- Individualised Food
- Weapons
- ISO Cafe
- Potatoe Season
- Oslavna rec. Speech
- Periscope out of scrap
- CCTV cameras
- Repair kiosk in Amsterdam
- Freedom free-doom
- solidarnosc clip
- IAU in ZK/U
- Kiosk v penzionu
- odlozeneho umeri
- Peripheral knowledge
- INI meetings
- LOS Legenda o sidlisti
- Opravy v Ceskem Krumlovi
- Nocni Cesky Krumlov
- EEP-2014
- Semestr SVU 2014
- Druzstevni publikace komiksu
- Navrh
- Ceskoslovenskeho pavilonu
- Silna kava v Berlino
- Zavarena mena
- Subconscious educative manual
- Tribute to instructions
- Waveform. Video to Voits
- Modely pro (Dis)harmon
- Kiosk pro A la recherche de la boheme perdue
- Gallery Ducato

past | minulost

- Pruhledna tajemstvi | Transparent Secret
- publikace KIOSK

"RATHER COMMITMENT THAN ARTIFACT"

Peripheral Knowledge is about the re-use of obsolete things and their repair. By repairing, producing or modifying, we shift from the position of consumer to the role of a real creator. This project provides the time and space for consultations, tutorials and practical lectures about work and activity that can be completed by the spectators in a series of workshops. Some of the tutorials are aimed at solving problems in the field of new media. The project casts the idea of DIY as a radical political activity and as a sort of activism that opposes the trends of mass production, conspicuous consumption, massive waste, corporate philosophy and the pre-designed lifetime of products.

My work refers to the actual state of the society I live in and I consider the role of an artist as an occupation strictly connected to society. I am therefore interested in artistic expression and reflection, in looking for alternative solutions. I see my experiments and re-use of objects in my art as a way of paying back to cultural and social heritage.

[Peripheral knowledge PDF book CZ](#)







Text



Utopie pro kazdy den

future | budoucnost

- IT Trojan Tactic
- Studio
- TRUE IS: WHERE
- TRASH IS:
- 25 Forgotten Buildings
- bar at Great Wall
- Factory for the Absolute
- Dirty paintings
- Hair Interna
- Individualised Food
- Weapons
- ISO Cafe
- Potatoe Season
- Oslavna rec. Speech
- Periscope out of scrap
- CCTV cameras
- Repair kiosk in Amsterdam
- Freedom free-doom
- solidarnosc clip
- IAU in ZK/U
- Kiosk v penzionu
- odlozeneho umeri
- Peripheral knowledge
- INI meetings
- LOS Legenda o sidlisti
- Opravy v Ceskem
- Krumlovi
- Nozni Cesky Krumlov
- EEP 2014
- Semestr SVU 2014
- Druzstevni publikace
- komiksu
- Navrh
- Ceskoslovenskeho pavilonu
- Silna kava v Berlina
- Zavarena mena
- Subconscious educative manual
- Tribute to instructions
- Waveform. Video to
- Volts
- Modely pro
- (Dis)harmon
- Kiosk pro A la
- recherche de la boheme perdue
- Gallery Ducato

past | minulost

- Pruhledna tajemstvi |
- Transparent Secret
- publikace KIOSK

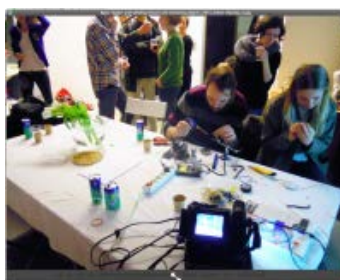

Involvement VS. Formal Aestheticism

2 month residency in INI gallery [INI web](#)

Corrections and emancipation of an artist through the acquirement of new skills in the area of Elektrické podniky. State of broken object and mental preparation for repair. Simple and accessible tools for basic repairs.

Instead of exhibiting Art products were visitors to take active participation during 4 meetings at Elektrické podniky in Prague.

Involvement won over Formalism and Aestheticism.

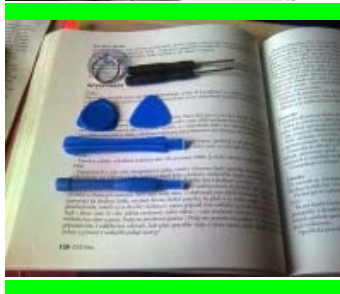
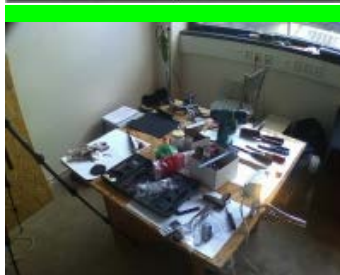



Text



Utopie pro kazdy den

future | budoucnost

- IT Trojan Tactic
- Studio
- TRUE IS WHERE
- TRASH IS
- 25 Forgotten Buildings
- bar at Great Wall
- Factory for the Absolute
- Dirty paintings
- Hair Internal
- Individualised Food
- Weapons
- ISO Cafe
- Potatoe Season
- Oslovna rec. Speech
- Periscope out of scrap
- CCTV cameras
- Repair kiosk in
- Amsterdam
- Freedom free-doom
- solidarnosc clip
- IAU in ZK/U
- Kiosk v penzionu
- odlozeneho umeri
- Peripheral knowledge
- INI meetings
- LOS Legenda o sidlisti
- Opravy v Ceskem
- Krumlovi
- Nočni Cesky Krumlov
- REP. 2014
- Semestr SVU 2014
- Druzstevni publikace
- komiksu
- Navrh
- Ceskoslovenskeho
- pavilonu
- Silna kava v Berlino
- Zavarena mena
- Subconscious educative
- manual
- Tribute to instructions
- Waveform. Video to
- Volts
- Modely pro
- (Dis)harmon
- Kiosk pro A la
- recherche de la boheme
- perdue
- Gallery Ducato

past | minulost

- Pruhledna tajemství |
- Transparent Secret
- publikace KIOSK

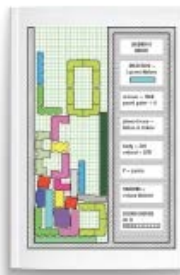

LEGENDA O SÍDLIŠTI

ed. Marketa Mrackova, Barbora Simonova, Viktor Vejvoda
 published by Akademie výtvarných umění v Praze and cosa.cz
 2014
 Tiskárny Havlíckuv Brod
 ISBN 978-80-87108-53-6

[LOS a Cosa.cz](http://los.a.cosa.cz)

LEGEND OF PREFABRICATED HOUSING ESTATE

This book describes a journey undertaken round Prague's prefab housing estates to examine their current state. Our journey became an expedition. Our initial experiences encouraged us to delve deeper. To obtain direct experience

we turned to personalities living in the estates, and to authorities on the subject, who are in some way connected to the topic. We chose experts

reflecting themes associated with mass public housing construction, promoting the quality of this housing or those who live in these housing complexes. Longtime residents describe their personal stories on obtaining housing, migration and transformation of the settlements over time. We conducted interviews with architects involved in the construction of Prague's housing estates. Architect Jiri Lasovsky talks about the origins of Southern City (Jižní Mesto), Vitezslava Rothbauerová was involved in the formation of Southern City II (Jižní Mesto II), and Ivo Oberstein talks about the emergence of Southwestern City (Jihozápadní Mesto). The names emphasize the size of these projects. Our guest architect is Bronislav Firla from Horní Suchá, who speaks about the construction and city development in the Ostrava region in the second half of 20th century. Views of architects are supported by an interview with a theorist of architecture, Radomíra Sedláková, and with the historian and theorist of architecture, Rostislav Švácha. Other contributors include the philosopher Erazim Kohák, geologist and writer Václav Čílek and urban geographer and anthropologist Petr Gibas. In terms of the realization of art in public space we have the thoughts of sculptor Jan Kryštufek and about a daily life in a block of flats we talked to painter Jan Jungling. Carpenter and enthusiast

for housing estates Marian Lipták talks on selected types of panel systems. Miluše Rothová discusses life in a tenant building from an elderly perspective, whilst childhood memories of growing up in the blocks are shared by Vít Podrásky and Miroslav Pazdera.

Prague's housing estates are now a quality place to live. Housing developments have been enhanced by green public spaces. Planned metro stations were completed and amenities have been continually upgraded. The original complaints on poor living conditions are being rectified. Their original purpose was to provide affordable housing for people whose prospects otherwise would be a room in a flat shared with their parents. After the Velvet Revolution this type of construction was marginalized and identified with the former regime. Society considered the demolition of this type of prefabricated housing project and promoted the densification of these areas. Fortunately, there was not enough funding for this to be carried out.

Today, as housing becomes an unfordable luxury again, people have to choose between either a life of debt with a large mortgage or paying high rental costs. A cohesive housing policy currently does not exist and an apathetic political system is unwilling to support the construction of affordable housing. How to deal with this situation is up to us.



Text



Utopie pro kazdy den

future | budoucnost

- IT Trojan Tactic
- Studio
- TRUE IS: WHERE
- TRASH IS:
- 25 Forgotten Buildings
- bar at Great Wall
- Factory for the Absolute
- Dirty paintings
- Hair Internat
- Individualised Food
- Weapons
- ISO Cafe
- Potatoe Season
- Oslavna rec. Speech
- Periscope out of scrap
- CCTV cameras
- Repair kiosk in Amsterdam
- Freedom free-doom
- solidarnosc clip
- IAU in ZK/U
- Kiosk v penzionu odlozeného umění
- Peripheral knowledge
- INI meeting
- LOS Legenda o sidlisti
- Opravy v Ceskem Krumlove
- Nocni Cesky Krumlov
- SEP 2014
- Semestr SVU 2014
- Druzstevni publikace
- komiks
- Navrh
- Ceskoslovenskeho pavilonu
- Silna kava v Berlino
- Zavazna mena
- Subconscious educative manual
- Tribute to instructions
- Waveform. Video to volts
- Modely pro (Dis)harmon
- Kiosk pro A la recherche de la boheme
- perdue
- Gallery Ducato

past | minulost

- Pruhledna tajemství | Transparent Secret
- publikace KIOSK

VEŘEJNÁ OPRAVNA ROZBITÝCH PŘEDMĚTŮ A KONZULTACE MOŽNOSTI JEJICH OPRAVY *Repair protocols in Cesky Krumlov*

V rámci rezidence v Egon Schiele Art Centru nabízím bezplatnou opravu rozbitých věcí, případně konzultaci jejich stavu a možnosti jejich vyřešení. Oprava a konzultace jsou prováděny bezplatně v průběhu listopadu 2014.

KONTAKT	ADRESA
+420 774 006 059 viktorhelp@seznam.cz	Hradební B1, Český Krumlov Residence Egon Schiele C.

30 protokolu oprav v Ceskem Krumlove
30 repair protocols in Cesky Krumlov

V rámci rezidence v Egon Schiele Art Centru jsem provozoval veřejnou opravnu rozbitých věcí a poradnu. Velkou část protokolu tvoří také opravy samotného atelieru a prostoru pro umělce.

As part of residency in Egon Schiele Art Center I run public repair service of damaged things and advice. Big part of repairs was studio and artists living space.

Residence byla zakončena country vernisáží a týdenní výstavkou protokolu v nastence za rohem.





Utopie pro kazdy den

future | budoucnost

- IT Trojan Tactic
- Studio
- TRUE IS: WHERE
- TRASH IS:
- 25 Forgotten Buildings
- bar at Great Wall
- Factory for the Absolute
- Dirty paintings
- Hair Internat
- Individualised Food
- Weapons
- ISO Cafe
- Potatoe Season
- Oslavna rec, Speech
- Periscope out of scrap
- CCTV cameras
- Repair kiosk in
- Amsterdam
- Freedom free-doom
- solidarnosc clip
- IAU in ZK/U
- Kiosk v penzionu
- odlozeneho umeri
- Peripheral knowledges
- INI meetings
- LOS Legenda o sidlisti
- Opravy v Ceskem
- Krumlovi
- Nocni Cesky Krumlov
- EFP_2014
- Semestr SVU 2014
- Druzstevni publikace
- komiksu
- Navrh
- Ceskoslovenskeho
- pavilonu
- Silna kava v Berlina
- Zavarena mena
- Subconscious educative
- manua
- Tribute to instructions
- Waveform, Video to
- Voits
- Modely pro
- (Dis)harmon
- Kiosk pro A la
- recherche de la boheme
- perdue
- Gallery Ducato

past | minulost

- Pruhledna tajemstvi



Text

Nocni Cesky Krumlov

Pribehly a dramata Hradebni ulice cislo 81
2014

- 01 > nejvetsi kurva jsem ja - co jako >> 00.06am >>>0:05s
- 02 > chovej se jako clovek >> 00.07am >>>0:10s
- 03 > nazdar >> 00.35am >>>0:17s
- 04 > navsteva ze SRN >> 00.55am >>>0:31s
- 05 > high heels nastup na scenu >> 01.05am >>>0:22s
- 06 > taxi 1 >> 01.08am >>>0:12s
- 07 > taxi 2 >> 01.09am >>>0:25s
- 08 > taxi 3 >> 01.11am >>>0:13s
- 09 > taxi 4 >> 01.15am >>>0:13s
- 10 > it is just so sad >> 01.18am >>>0:22s
- 11 > ty taky pijes pivo >> 01.42am >>>0:28s
- 12 > cekal jsem na vas 2 hodiny >> 02.08am >>>0:36s
- 13 > nevypadas jako Marfusa >> 02.16am >>>0:20s
- 14 > high heels ustup ze sceny >> 04.06am >>>0:13s
- 15 > nech ho - zabiju te >> 04.47am >>>0:57s
- 16 > vrabci I >> 05.43am >>>0:07s
- 17 > vrabci II >> 06.41am >>>0:10s
- 18 > metari >> 06.52am >>>0:32s

stazeni celeho alba NOCNI KRUMLOV EEP_2014



Utopie pro kazdy den

future | budoucnost

- IT Trojan Tactic
- Studio
- TRUE IS: WHERE
- TRASH IS:
- 25 Forgotten Buildings
- bar at Great Wall
- Factory for the Absolute
- Dirty paintings
- Hair Internat
- Individualised Food
- Weapons
- ISO Cafe
- Potatoe Season
- Oslavna rec. Speech
- Periscope out of scrap
- CCTV cameras
- Repair kiosk in
- Amsterdam
- Freedom free-doom
- solidarnosc clip
- IAU in ZK/U
- Kiosk v penzionu
- odlozeneho umeri
- Peripheral knowledge
- INI meeting
- LOS Legenda o sidlisti
- Opravy v Ceskem
- Krumlovi
- Nocni Cesky Krumlov
- EEP 2014
- Semestr SVU 2014
- Druzstevni publikace
- komiksu
- Navrh
- Ceskoslovenskeho
- pavilonu
- Silna kava v Berlino
- Zavarena mena
- Subconscious educative
- manual
- Tribute to instructions
- Waveform. Video to
- Volts
- Modely pro
- (Dis)harmon
- Kiosk pro A la
- recherche de la boheme
- perdue
- Gallery Ducato

past | minulost

- Pruhledna tajemstvi |
- Transparent Secret
- publikace KIOSK



Kolektivni semestr v **Salonu vytvarnych umeni (SVU)**, 2014.
Semestr probihal pod dohledem bystrego oka Artura Zmijewskeho.

Collective term in **Saloun of Fine Arts (SVU)**, 2014
Under supervision of Artur Zmijewski.

Stránka mapujici prubeh semestru | page mapping term development

> > >
SVU 2014



Text



Utopie pro kazdy den

future | budoucnost

- IT Trojan Tactic
- Studio
- TRUE IS: WHERE
- TRASH IS:
- 25 Forgotten Buildings
- bar at Great Wall
- Factory for the Absolute
- Dirty paintings
- Hair Interna
- Individualised Food
- Weapons
- ISO Cafe
- Potatoe Season
- Oslavna rec, Speech
- Periscope out of scrap
- CCTV cameras
- Repair kiosk in
- Amsterdam
- Freedom free-doom
- solidarnosc clip
- IAU in ZK/U
- Kiosk v penzionu
- odlozeneho umeri
- Peripheral knowledge
- INI meeting
- LOS Legenda o sidlisti
- Opravy v Ceskem
- Krumlovi
- Nocni Cesky Krumlov
- REP 2014
- Semestr SVU 2014
- Druzstevni publikace
- komiksu
- Navrh
- Ceskoslovenskeho
- pavilonu
- Silna kava v Berlina
- Zavarena mena
- Subconscious educative
- manua
- Tribute to instructions
- Waveform, Video to
- Voits
- Modely pro
- (Dis)harmon
- Kiosk pro A la
- recherche de la boheme
- perdue
- Gallery Ducato

past | minulost

- Pruhledna tajemstvi |
- Transparent Secret
- publikace KIOSK



Kniha je samizdatovym druzstevnim sbornikem, ktery byl vytisten sitotiskovou technikou. Tematem sborniku je cirkus.

The book is a self-published co-op collection, made with a screen printing techniques. The main theme of the collection is circus.

[KIOSK BOOKS link](#)



Text



Utopie pro kazdy den

future | budoucnost

- [IT Trojan Tactic Studio](#)
- [TRUE IS WHERE TRASH IS](#)
- [25 Forgotten Buildings](#)
- [bar at Great Wall](#)
- [Factory for the Absolute](#)
- [Dirty paintings](#)
- [Hair Internal](#)
- [Individualised Food](#)
- [Weapons](#)
- [ISO Cafe](#)
- [Potatoe Season](#)
- [Oslavna rec „Speech](#)
- [Periscope out of scrap](#)
- [CCTV cameras](#)
- [Repair kiosk in Amsterdam](#)
- [Freedom free-doom](#)
- [solidarnosc clip](#)
- [IAU in ZK/U](#)
- [Kiosk v penzionu](#)
- [odlozeného umení](#)
- [Peripheral knowledge](#)
- [INI meetings](#)
- [LOS Legenda o sídlišti](#)
- [Opravy v Ceskem](#)
- [Krumlovi](#)
- [Nočni Cesky Krumlov](#)
- [KEP-2014](#)
- [Semestr SVU 2014](#)
- [Druzstevni publikace, komiksu](#)
- [Navrh](#)
- [Ceskoslovenskeho pavilonu](#)
- [Silna kava v Berlino](#)
- [Zavarena mena](#)
- [Subconscious educative manual](#)
- [Tribute to instructions](#)
- [Waveform, Video to Voits](#)
- [Modely pro \(Dis\)harmonii](#)
- [Kiosk pro A la recherche de la bohème perdue](#)
- [Gallery Ducato](#)

past | minulost

[Pruhledna tajemství](#)

Biennale 2014 — navrh realizace

Marketa Mrackova, Marek Silar, Milan Vales, Viktor Vejvoda

Kazdodenni ritual

Hledani zakladu architektury

Tema bienale „hledani zakladu architektury“ rozvadime fenomenem drobne architektury. Stanky, cekarny, pristresky, nastenky, zabradli, odpadkove kose, telefoni budky, verejne zachodky a lavicky tvori nezdolne podhoubi pralesa ceske architektury. Verime, ze v teto typologii se skryva mnoho kvality, které se z vysoke architektury vytratili. Ocenujeme jejich spontanost, originalitu a regionalni specificnost. Tyto stavby slouzi vsem. Spodni vrstve není potreba rozumet — proste se uziva. Naplňuje zakladni lidske potreby a casto ma i pozoruhodne estetické kvality.

Zive obrazy

Expozici chapeme jako divadlo zinscenovane na pocesť cinnosti a situaci odehravajících se okolo drobnych staveb. Nevytvárimo vystavu, ale zivy obraz kazdodenni ceske reality plynouci v bezcasi minulých dekad.

Koreny

V kiosku je mozne zakoupit jak klasické obcerstveni, tak rozlicne tematicke artefakty — vystrihovanky drobnych staveb, architektonicke publikace, ci pruty na opekani burtu. Vysoke architektury bylo dost, je cas zabyvat se spodni urodnuou vrstvou. Nase koreny rostou prave z ni.

Biennale 2014 navrh realizace PDF

VENKOVATE MARELI



VENKOVATE MARELI



ve městě jako ve venkově

Dotazník

sklad

Průhledna je jen průhledná. Dvůr je to kiosk.

Společně se svou je město — správně, adaptivně, obdivně, rozdílně, přehledně, vylučně, ostrážně — přesto má pozoruhodně silný kořenek

jakou úroveň

úroveň fundamentální

Z praxe v pavilonu se lidé hradí a vyzírají vůči městu nepřehledně strážně výhled.

Text



Utopie pro kazdy den

future | budoucnost

- IT Trojan Tactic
- Studio
- TRUE IS: WHERE
- TRASH IS:
- 25 Forgotten Buildings
- bar at Great Wall
- Factory for the Absolute
- Dirty paintings
- Hair Internat
- Individualised Food
- Weapons
- ISO Cafe
- Potatoe Season
- Oslavna rec. Speech
- Periscope out of scrap
- CCTV cameras
- Repair kiosk in
- Amsterdam
- Freedom free-doom
- solidarnosc clip
- IAU in ZK/U
- Kiosk v penzionu
- odlozeneho umeri
- Peripheral knowledge
- INI meetings
- LOS Legenda o sidlisti
- Opravy v Ceskem
- Krumlovi
- Nocni Cesky Krumlov
- EEP-2014
- Semestr SVU 2014
- Druzstevni publikace
- komiksu
- Navrh
- Ceskoslovenskeho
- pavilonu
- Silna kava v Berlina
- Zavarena mena
- Subconscious educative
- manua
- Tribute to instructions
- Waveform. Video to
- Volts
- Modely pro
- (Dis)harmon
- Kiosk pro A la
- recherche de la boheme
- perdue
- Gallery Ducato

past | minulost

- Prhledna tajemstvi |
- Transparent Secret
- publikace KIOSK



Kofeinizace návštevníku galerie

Návštevníkům Kunsthalle Berlin jsem varil silnou kávu a každému jsem dal listek s poradím jeho sálku.

Caffeinization of gallery visitors

I made strong coffee for visitor of Kunsthalle Berlin. Each got signed number of cup.



Přidavná spojení II. / **Kunsthalle am Hamburger Platz**, Berlin 2013
(kurator Tereza Severova a Christl Mudrak)



Text



Utopie pro každý den

future | budoucnost

- IT Trojan Tactic
- Studio
- TRUE IS WHERE
- TRASH IS
- 25 Forgotten Buildings
- bar at Great Wall
- Factory for the Absolute
- Dirty paintings
- Hair Internet
- Individualised Food
- Weapons
- ISO Cafe
- Potatoe Season
- Oslavná rec. Speech
- Periscope out of scrap
- CCTV cameras
- Repair kiosk in
- Amsterdam
- freedom free-doom
- solidarosc clip
- LAN in ZK/Ú
- Kiosk v penzionu
- odlozeného umění
- Peripheral knowledges
- INI meetings
- LOS Legenda o sidisti
- Opravy v Ceskem
- Krumlovi
- Noční Český Krumlov
- EEP 2014
- Semestr SVU 2014
- Družstevní publikace
- kamiku
- Navrh
- Československého pavilonu
- Silná káva v Berlíně
- Zavarena mena
- Subconscious educative manual
- Tribute to Instructions
- Waveform. Video to
- Volta
- Modely pro
- (Dis)harmoni
- Kiosk pro A ja
- recherche de la bohème
- perdue
- Gallery Ducato

past | minulost

- Průhledná tajemství
- Transparent Secret
- publikace KIOSK



Kiossek se zavarenou menou



Kiosk with pickled currency

Cena EXIT 2013

[Exit Web](#)



old sošeckým kioskem: Hommage to the Kiosks of Usti nad Labem from Viktor z Utopie on Vimeo.

Zavarena mena

Střecha domu po me babicce byla opravena z penez, které byly zavarene. Moje babicka a deda zili velmi skromne v dome na okraji mesta. Zazili chuda leta a v pozdnim obdobi zivota pro ne vyplata duchodu znamenala pojittko s zivotem. Penize urcene na uhlí a jidlo. Vse co babicka usetrila ze sveho duchodu schovavala. Bylo podvedome iracionalni setreni penez na horsi casy. Schovavala je pred rodinou pro rodinu.

Po letech jsme vyklizeli sklep. Stare zavareniny. Archiv ovoce a zeleniny. Rocniky 1976, 77... ktere bylo mozne jeste ochutnat. Neco jako steak z mamuta, hnus a dobrota v jedne lahvi. Neidentifikovatelné barevne a sladke obsahy. A uplne vzadu regalu zaprasene zavarovacky a v nich mirne vlhkem zkroucene, nazelenale ale stale platne bankovky. Babiccina zavarenina. Energeticke poselstvi dalsi generaci. Sklenena kamepicka.

Ve Vietnamske trznici Sapa muzete koupit baliky natistenych penez. V nabidce jsou bankovky euro a dolary. Balicky jsou uhledne srovnane v pultu a zabalene do celofanu. Jeden balicek stojí dvacet korun. Dolary vypadaji o neco vice povedene. Lze cítit vuni noveho papiru s tiskarskou barvou.

V buddhisticke tradici lze obetovat místo opravdovych bankovek, bankovky falešne. Bozstva mají velké srdce a zastupny dar prijmu. Obetina přinese stesti jak zemřelým příbuzným, tak rodině doposud žijící. Spaleny papírek se mnohonásobně zhodnotí a přinese stesti.

Nemecky deník cituje finančního experta: Bundesbank prave tiskne nove nemecke marky. Zavarte si svoje Eura na horsi casy.

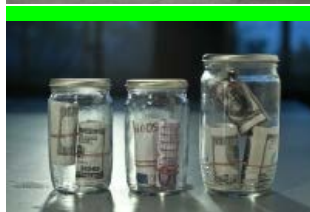



Utopie



Utopie pro každý den

future | budoucnost

[IT Trojan Tactic](#)

[Studio](#)

[TRUE IS: WHERE](#)

[TRASH IS:](#)

[25 Forgotten Buildings](#)

[bar at Great Wall](#)

[Factory for the Absolute](#)

[Dirty paintings](#)

[Hair Interiors](#)

[Individualised Food](#)

[Weapons](#)

[ISO Cafe](#)

[Potatoes Season](#)

[Oslavná rec. Speech](#)

[Periscope out of scrap](#)

[CCTV cameras](#)

[Repair kiosk in](#)

[Amsterdam](#)

[freedom tree -boom](#)

[solidarosc clip](#)

[LAI in ZK/Ú](#)

[Kiosk v penzionu](#)

[odlozeného umění](#)

[Peripheral knowledges](#)

[INI meetings](#)

[LOS Legenda o sídlisti](#)

[Opravy v Ceskem](#)

[Krumlov](#)

[Noční Český Krumlov](#)

[EEP_2014](#)

[Semestr SVU 2014](#)

[Družstevní publikace](#)

[komiksu](#)

[Navrh](#)

[Československého](#)

[pavilonu](#)

[Silná káva v Berlíně](#)

[Zavazna mana](#)

[Subconscious educative](#)

[manual](#)

[Tribute to Instructions](#)

[Waveform. Video to](#)

[Volta](#)

[Modely pra](#)

[\(Dis\)harmoni](#)

[Kiosk pro A ja](#)

[recherche de la bohème](#)

[perdue](#)

[Gallery Ducati](#)

past | minulost

[Přehledná tajemství](#)



Subconscious educative manual

Duo Hemisphere Projection

(stereo-video loop, 7.22min)

Subconscious sentences

Ash tray is nasty

Do not smoke in this room

Wash your dishes

Even dirty dishes is good, it indicates how wealthy we are

AVU container is obscene ecological gesture



Podprahove naučne video

Projekce do obou hemisfer

(stereo-video smyčka, 7.22min)

Podprahove vety

Popelník je hnusný

Nekur v této místnosti

Umyj si své nádoby

I neumyte nádoby je poučné, ukazuje jak moc dobře se nám vede

Kontejner AVU s odpadem je obscenní gesto vůči ekologii

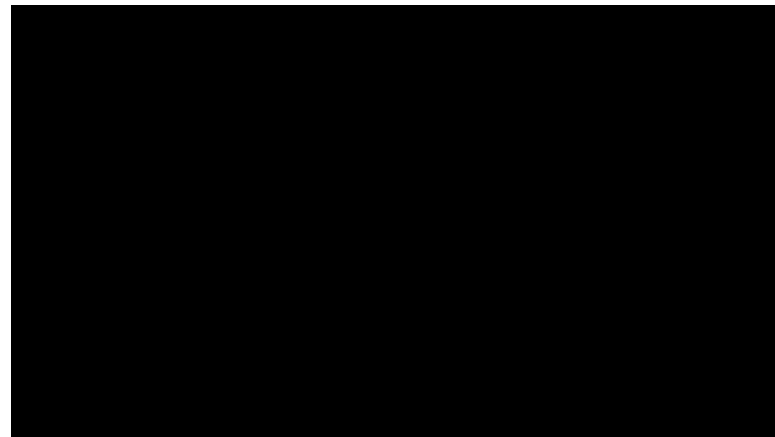

[Subconscious educative manual / Podprahove naučne video](#) from [Viktor z Utopie](#) on [Vimeo](#).



Utopie pro každý den

future | budoucnost

- IT Trojan Tackla
- Studio
- TRUE IS: WHERE
- TRASH IS
- 25 Forgotten Buildings
- bar at Great Wall
- Factory for the Absolute
- Dirty paintings
- Hair Interiors
- Individualised Food
- Weapons
- ISO Cafe
- Potatoes Season
- Oslavná rec. Speech
- Periscope out of scrap
- CCTV cameras
- Repair kiosk in
- Amsterdam
- freedom tree-loom
- solidarosc clip
- IAU in ŽK/Ú
- Kiosk v penzionu
- odlozeného umění
- Peripheral knowledges
- INI meetings
- LOS Legenda o sídlisti
- Opravy v Česku
- Krumlov
- Noční Český Krumlov
- EEP_2014
- Semestr SVU 2014
- Družstevní publikace
- kamiku
- Navrh
- Československého
- pavilonu
- Silná káva v Berlíně
- Zavazna mana
- Subconscious educative
- manual
- Tribute to Instructions
- Waveform. Video to
- Volta
- Modely pra
- (Dis)harmon
- Kiosk pro A ja
- recherche de la bohème
- perdue
- Gallery Ducati

past | minulost

- Průhledná tajemství
- Transparent Secret
- publikace KIOSK



Tribute to instructions

I decide to pay tribute to instructions and manuals of any kind. Individual in this field has great window of opportunity for exiting simple customer—consumer role.

Manuals and instructions exist in direct contrast to all warranty conditions. It is path full of excitement, danger, discovery and fun.

I dedicate this installation to emancipation and humanization power of repairing and reusing. Different kind of instruction videos and text was my inspiration source. I create engaged series of manual—like loops. These instructive testaments can enforce to recycle, repair and reuse. All four items of installation is running on recycled, in trash founded and reused technology. Art is not just about introspective topics. Artist should try to name local and global problems. All kind of weapons are possible.

All material and tools used in this installation is recycled and repaired from worn-out and amortized technique .



Na počest navodu

Vzdávám hold navodum a manualum vseho druhu. Clovek ma v teto oblasti jedinecnou prilezitost opustit jednotvarnou vnucenou roli zakaznik—konzument.

Navody existuji v primem kontrastu k zarucnim podminkam a zakonu o zpetnem inzenyrstvi. Jsou cestou plnou vzruseni, nebezpeci, objevovani a zabavy.

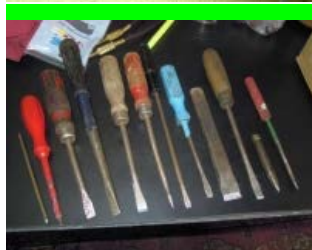

Celou instalaci venuji moznosti emancipace a humanizacni sily, ktera je ukryta v opravovani a znovupouziti jiz existujicich veci. Vytvarim serii angazovanych manualu, ktere nabadaji k opravovani, recyklovani a znovu uziti. Vsechny videa bezi na prostredcich nalezenych v odpadu nebo urcenyh ke skartaci. Umeni by nemelo byt jen do sebe zahledenym oborem. Umelci maji pojmenovavat lokalni i globalni nesvary. Vsechny zpusoby boje jsou povolene.



Vsechna technika pouzita v teto instalaci pochazi z vyhozeneho a odepsaneho vybaveni.

Fixing as a life 's attitude and a way to emancipation

(video loop, 3.45min)

Opravovani jako zivotni pristup a cesta k emancipaci

(video smycka, 3.45min)

Text

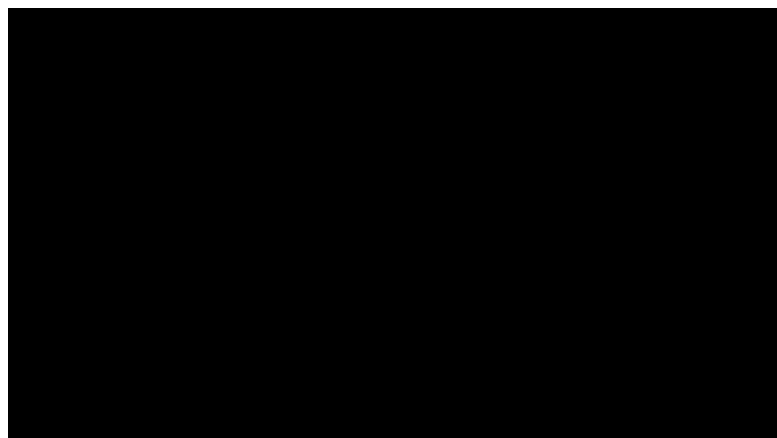

Fixing as a life 's attitude and a way to emancipation from Viktor z Utopie on Vimeo.



Utopie pro kazdy den

future | budoucnost

- IT Trojan Tactic
- Studio
- TRUE IS: WHERE
- TRASH IS:
- 25 Forgotten Buildings
- bar at Great Wall
- Factory for the Absolute
- Dirty paintings
- Hair Internal
- Individualised Food
- Weapons
- ISO Cafe
- Potatoe Season
- Oslovna rec. Speech
- Periscope out of scrap
- CCTV cameras
- Repair kiosk in
- Amsterdam
- Freedom free-doom
- solidarnosc clip
- IAU in ZK/U
- Kiosk v penzionu
- odlozeneho umeni
- Peripheral knowledge
- INI meetings
- LOS Legenda o sidlisti
- Opravy v Ceskem
- Krumlovi
- Nocni Cesky Krumlov
- REP. 2014
- Semestr SVU 2014
- Druzstevni publikace
- komiksu
- Navrh
- Ceskoslovenskeho
- pavilonu
- Silna kava v Berlina
- Zavarena mena
- Subconscious educative
- manual
- Tribute to instructions
- Waveform. Video to
- Volts
- Modely pro
- (Dis)harmon
- Kiosk pro A la
- recherche de la boheme
- perdue
- Gallery Ducato

past | minulost

- Pruhledna tajemstvi
- Transparent Secret
- publikace KIOSK



Waveform. Video to Volts

oscilloscope and speakers installation, video loop 2.01min

I go around park fountain like slow motion Dervish, like Shaker. Like Kalugin In Dream from Daniil Charms.

A waveform monitor is a special type of oscilloscope used in television production applications. It is typically used to measure and display the level, or voltage, of a video signal with respect to time.



In projection spectator see image designed to estimate quality of video output. From volt visualisation curves and from original sound can be whirling movement imagined.

The Dream, Daniil Charms

Kalugin fell asleep and had a dream that he was sitting in some bushes and a policeman was walking past the bushes.

Kalugin woke up, scratched his mouth and went to sleep again and had another dream that he was walking past some bushes and that a policeman had hidden in the bushes and was sitting there.

Kalugin woke up, put a newspaper under his head, so as not to wet the pillow with his dribblings, and went to sleep again; and again he had a dream that he was sitting in some bushes and a policeman was walking past the bushes.

Kalugin woke up, changed the newspaper, lay down and went to sleep again. He fell asleep and had another dream that he was walking past some bushes and a policeman was sitting in the bushes.

At this point Kalugin woke up and decided not to sleep any more, but he immediately fell asleep and had a dream that he was sitting behind a policeman and some bushes were walking past.

Kalugin let out a yell and tossed about in bed but couldn't wake up.

Kalugin straight through for four days and four nights and on the fifth day he awoke so emaciated that he had to tie his boots to his feet with string, so that they didn't fall off. In the bakery where Kalugin always bought wheaten bread, they didn't recognize him and handed him a halfrye loaf.

And a sanitary commission which was going round the apartments, on catching sight of Kalugin, decided that he was unsanitary and no use for anything and instructed the janitors to throw Kalugin out with the rubbish. Kalugin was folded in two and thrown out as rubbish.



Text

Casovy prubeh vlny, z videa na volty

instalace z osciloskopu, smycka 2.01min

Chodim kolem fontany v parku jako zpomaleny dervis, jako shaker. Jako Kalugin ve Snu od Daniila Charmse.

Casova prubeh vlny (waveform monitor) je specialni typ osciloskopu pouzivaneho v televizni produkci. Je uzivany k mereni a zobrazeni urovne jasu videa v zavislosti na case.

Divak muze v projekci urcene k odhadnuti formalni kvality video vystupu zahlednout odraz puvodniho vireni.

Sen, Daniil Charms

Kalugin usnul a tohle se mu zdalo: sedi v krovi a okolo krovi se prochazi milicionar. Kalugin se probudil, poskrabal se na puse, znovu usnul a zdalo se mu tohle: prochazi se okolo krovi, ve kterem sedi schovany milicionar. Kalugin se probudil, pod hlavu si dal noviny, aby si neslital na polstar, znovu usnul a zdalo se mu, ze sedi v krovi a okolo jde milicionar. Kalugin se probudil, vymenil noviny, lehl si a usnul. Usnul a znovu se mu zdal sen, jak sedi za milicionarem a okolo se prochazeji kere. Kalugin zarval, zazmital sebou v posteli a uz se neprobudil.

Spal nepretržite čtyři dny a noci. Paty den se probudil tak zeslably, ze si boty musel privazat provazkem k noham, aby mu nespadly. V obchode, kde si vzdycky kupoval pšenický chleba, Kalugina nepoznali a strčili mu chleba položitny. Zdravotní hygienická komise při prohlídce bytu shledala Kalugina hygienicky zavadným a k nicemu se nehodícím a prikazala bytovemu

druzstvu vyhodit Kalugina spolecne se smetim. Kalugina prelozili napul a vyhodili ho jako odpad.



Utopie pro kazdy den

future | budoucnost

- IT Trojan Tactic
- Studio
- TRUE IS WHERE
- TRASH IS
- 25 Forgotten Buildings
- bar at Great Wall
- Factory for the Absolute
- Dirty paintings
- Hair Internat
- Individualised Food
- Weapons
- ISO Cafe
- Potatoe Season
- Oslavna rec. Speech
- Periscope out of scrap
- CCTV cameras
- Repair kiosk in
- Amsterdam
- Freedom free-doom
- solidarnosc clip
- IAU in ZK/U
- Kiosk v penzionu
- odlozeneho umeri
- Peripheral knowledge
- INI meetings
- LOS Legenda o sidlisti
- Opravy v Ceskem
- Krumlovi
- Nocni Cesky Krumlov
- EEP_2014
- Semestr SVU 2014
- Druzstevni publikace
- komiksu
- Navrh
- Ceskoslovenskeho
- pavilonu
- Silna kava v Berlino
- Zavarena mena
- Subconscious educative
- manua
- Tribute to instructions
- Waveform. Video to
- Volts
- Modely pro
- (Dis)harmonii
- Kiosk pro A la
- recherche de la boheme
- perdue
- Gallery Ducato

past | minulost

- Pruhledna tajemstvi |
- Transparent Secret
- publikace KIOSK



Modely drobných staveb pro výstavu (Dis)harmonie v galerii Kibla, Maribor, Slovinsko
19. 6.>7. 7. 2013

Models is drawn to the "edge", where the most significant changes occur; where images are disappearing and new ones are being created; where an endless process of urban and socio-psychological changes take place. The artist sees the world of little people as self-initiative and an erosion of countless status symbols.

The presented work "Kiosk" is a hybrid architecture with a specific identity (a temporary building construction), which directs us into the exploration of relationships between the lower-class community and its corresponding organic space. It is interesting that Vejvoda never falls into criticism, but rather tells the story of men, whose experiences are related to survival, not to capital. His projects are socially, ecologically and culturally conscious inside the capital's power and its architectural mightiness; but above all they are a simple artistic statement that, by means of a fragile architecture, as inconstant as life itself, reveals the man "on the edge".

The exhibition is a poem of reality. In their own artistic language and medium, with an esthetic experience and emotional charge, each of the artists presents their own particular visual context.

Alenka Domjan, curator



Text



Utopie pro kazdy den

future | budoucnost

- [11. Trojan Tackl.](#)
- [Studio](#)
- [TRUE IS: WHERE](#)
- [TRASH IS:](#)
- [25 Forgotten Buildings](#)
- [bar at Great Wall](#)
- [Factory for the Absolute](#)
- [Dirty paintings](#)
- [Hair: Interiors](#)
- [Individualised Food](#)
- [Weapons](#)
- [ISO Cafe](#)
- [Potatoes Season](#)
- [Oslavna rec: Speech](#)
- [Periscope out of scrap](#)
- [CCTV cameras](#)
- [Repair kiosk in](#)
- [Amsterdam](#)
- [freedom free-doom](#)
- [solidarnosc clip](#)
- [LAI in ZK/0](#)
- [Kiosk v penzionu](#)
- [odlozeného umění](#)
- [Peripheral knowledges](#)
- [INI meetings](#)
- [LOS: Legenda o sidlisti](#)
- [Opravy v Ceskem](#)
- [Krumlovi](#)
- [Nocni Cesky Krumlov](#)
- [EEP 2014](#)
- [Semestr SVU 2014](#)
- [Druzstevni publikace](#)
- [kamiksu](#)
- [Navrh](#)
- [Ceskoslovenskeho](#)
- [pavilonu](#)
- [Silná káva v Berlíně](#)
- [Zavazena mana](#)
- [Subconscious educative](#)
- [manual](#)
- [Tribute to Instructions](#)
- [Waveform: Video to](#)
- [Volta](#)
- [Modely pro](#)
- [\(Dis\)harmon](#)
- [Kiosk pro A la](#)
- [recherche de la bohème](#)
- [perdue](#)
- [Gallery Ducato](#)

past | minulost

- [Průhledná tajemství](#)
- [Transparent Secret](#)
- [publikace KIOSK](#)



Kiosk s kofeinovou nalevnou pro *A la recherche de la bohème perdue*

Neuchâtel 26.>29. 5. 2013

Zürich 31.5>2. 6. 2013

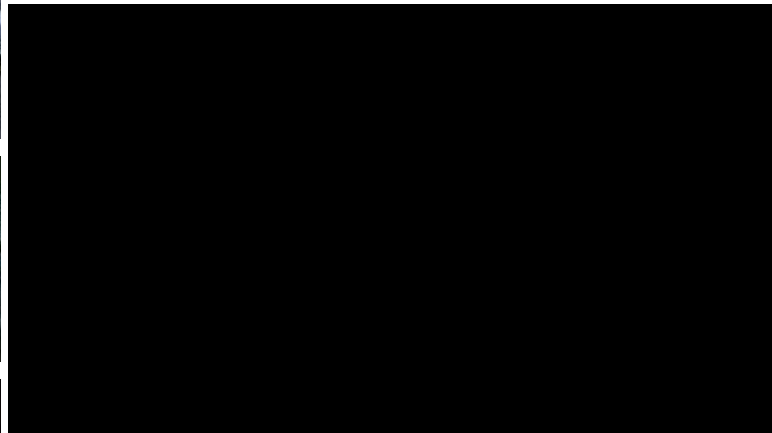

Kiosková kafeinzace 2013 from Viktor z Utopie on Vimeo.

Searching for the concept of the lost bohemian

Before we start to take a look at the evolution of the contemporary art scenes in Switzerland and the Czech Republic since the fall of the wall in 1989, we should be aware which kind of approach each protagonist has towards the other in this day and age. For us in Switzerland, this means, working with institutions and artists from a so-called «ex east block country» or “former east”[1]. These terms are of course totally anachronistic labels, as they refer to a political blocks that no longer exist. Like always our point of view is defined from a situation, because if we are speaking of former east or soviet block countries or societies, why do we never refer to our country as former west or ex western block countries? Does this ghostly notion of the East persist only because of our inability to define new terms that are able to grasp the present? Or do we cherish a nostalgia, hoping to indirectly connect to the spirit of long-gone ideologies? The first thing that went away after the fall of the soviet block, was the fact that the world was divided into two systems which were separated by different ideological constructions. Because cultural exchange was prevented by the iron curtain, we started to acquire more and more nostalgic feelings towards the places we would never be able to visit. Maybe this is the reason why we like to refer to the former east countries because it seems to us better than any cynical postmodern definition of the current state of affairs in these societies. And as long as we haven't been able to invent something more positive or constructive than postmodernism, we'll have to deal with our part in this nostalgia.

We can accept a little bit of nostalgia, but revealing ones own exoticism is something that seems to be a bit more dangerous. Exoticism always implies that one is endorsing the colonial inheritance and crude and vulgar concepts of orientalism, while assuming ones own position at the center of the universe. Denying our craving for exoticism, by covering it up behind a well-intentioned neo-humanist discourse will only make matters worse, and will never get us to a point where we can free ourselves from our western centered point of view. We are not going to criticize exoticism in itself, but we have to take a close look from where the exoticism stems and what it is linked to. Having an exotic idea of the former east while living in the former west, is an anachronistic position and can't be held up, as both systems are now one. When we refer to an exotic place in using the words “former” or “ex”, we place it within the past, so in fact our exotic terminology refers to what we were, not towards what the exotic society is today.

So we end up with an anachronistic endo-exoticism, something that has also been called “interior exoticism”[2]. According to the principle of phenomenal existence, everything we do is based on representation, and that we conceive ourselves differently than we actually are. If our research is based on a passé geopolitical notion, we will end up with a blurred image of an individual exoticism. We came to know a lot about a world that would remain forever inaccessible, and through this the so-called east had a presence-absence. Are we forced to acknowledge an absence of absence? Czechoslovakia's counterculture before 1989 offered a fascinating array of different artists, and art forms. Again for geopolitical reasons the Czech underground groups like Plastic People of the Universe received extensive media coverage in the west, and dissidents like Vaclav Havel became household names. After the fall of communism, the protagonists of the counterculture movement moved into the highest offices. When the tables turned, the Prague underground scene lost its main figures to the institutions. This shift didn't empower the independent culture producers and artists, as the newly appointed culture officials had no interest in empowering critical voices around them. The most extreme example of this development is perhaps the curious case of the former dissident and fluxes artists Milan Knizak, who was appointed director of the national gallery, and because of his abuse of power became one of the most controversial figures among artists and the Czech public.

But there still is a lively and vibrant art scene in Prague that is mainly unknown to the western public. One of the missions of the project is to present and connect artists, activists and institutions who are shaping the Czech art scene to the Swiss public. Switzerland in turn is known to Czechs



as the land of banks and cleanliness, things that are not usually associated with counterculture. But Switzerland had and has a strong underground scene, which has always been at the forefront of changes made within the setup of the society. Today a city like Zurich is ruled by a mayor who takes pride in saying that she was a member of the youth movement of the 80ties. The economic success story of Switzerland is also due to its open civil society, empowered by grass roots movements, which often questioned the authority of the state. The Zurich squatting scene is one of these movements, and is driven by artists and culture activists. On our quest for the lost bohemians, we would like to present the Czech public the techniques and persons of these groups.

The best way to start the nostalgic search for lost bohemianism is most likely a voyage by land, traveling slowly in a vehicle and stopping on the way. The CAN and the D.I.V.O. Institute intend to create a mobile art space, consisting of a refurbished bus, and two army tents. These tents will form the backbone of the so-called mobile inhabited sculpture and is a collaborative artwork to which other artworks can be added and subtracted. The inhabited sculpture is also the backdrop for any actions, and through its mixed authorship it defies the idea of art as just being a mere commodity for rich investors. During the journey the installation in and around the mobile platform will grow, and at each stop its appearance will change.

We will take the road to Bohême. The word Bohême (fr, the region "Bohemia") is an explicit reference to the movement bohème ("bohemianism") which was a French counterculture in the late 19th century. The movement of the bohème rejected romanticism, an idea which they considered to be the emanation of the bourgeois culture. Let us note that a first contradiction appears in our projects historical references: searching for the bohème perdue ("lost bohemianism") on a journey is not exempt of romanticism (let us not forget that romanticism was developed from, amongst other things, Grand Tourists' travelings of the eighteenth century). One of the main differences between these two types of travelers (bohémians and Grand Tourists) was of course the amount of money that could be spent on a voyage. Our cultural pilgrimage will try to follow and avoid both these types of travel.

The bohème française ("French bohemianism") strongly influenced authors such as Hermann Hesse. Hesse spent a lot of time researching an elsewhere that he was attempting to find between the Orient and Occident. In following different branches of influence reconstructed by historians, bohème would be one of the sources of Dadaism, another branch passing through Hesse, leading to the Wandervogel movement to then pass to the United States and the Beat Generation, to culminate in writers like William S. Burroughs or, a bit later, Philip K. Dick. Elsewhere in hence no longer the same, it is no longer between two cultures, political systems or regions. The search for elsewhere is found in the Inter-zone, the intermediary between fiction and reality. What ever became of the bohémien elsewhere in today's contemporary art scene? We are obviously tempted to search within alternative or independent structures, in so called off spaces. In Switzerland there are many such places who that proclaim themselves as counterculture. At the same time these same places receive grants from foundations such as Nestlé pour l'Art, the same organizations that also funds museums, opera festivals and other large institutions showing high bourgeois culture. The term bobo[3], a contraction of "bourgeois" and "bohème", describes this contradiction, with a schizophrenic aftertaste. Counterculture and establishment view each other in similar way the opposing east and western blocks used to eye each other. Established institutions take elements from the counterculture, and the outcome of the discussions in museum and off spaces are often identical: contemporary art always should be critical and experimental.

In setting off à la recherche de la bohème perdue, we would like to take a look at the different contradictions of high and low, east and west, taking into account our endo-exotic side, nostalgic side, and maybe even the bobo character of our action. Thus, the first and third phase of the project will show one of these contradictions by confronting one exhibition of an institutional nature with an event that plays with counterculture's accepted codes. The utopian goal of the project consists of creating a shock between the two, a shock that should allow the appearance of a fissure giving access to an inter-zone beyond our contradictions.

The CAN and Mark Divo

[1] The notion of "former west" was developed in a research project led by the BAK (basis voor actuele kunst, Utrecht). q.v. www.formerwest.org

[2] Victor Segalen in his "Essay on exoticism", Claude Cahun, Jules de Gaultier, among others.

[3] The term bobo was coined by David Brooks to describe the descendants of yuppies in the 1990s.



Utopie pro kazdy den

future | budoucnost

- [IT Trojan Tactic](#)
- [Studio](#)
- [TRUE IS: WHERE](#)
- [TRASH IS:](#)
- [25 Forgotten Buildings](#)
- [bar at Great Wall](#)
- [Factory for the Absolute](#)
- [Dirty paintings](#)
- [Hair: Interiors](#)
- [Individualised Food](#)
- [Weapons](#)
- [ISO Cafe](#)
- [Potatoes Season](#)
- [Oslavna rec: Speech](#)
- [Periscope out of scrap](#)
- [CCTV cameras](#)
- [Repair kiosk in](#)
- [Amsterdam](#)
- [freedom tree-doom](#)
- [solidarnosc clip](#)
- [Kiosk in ZK/0](#)
- [Kiosk v penzionu](#)
- [odlozeného umění](#)
- [Peripheral knowledges](#)
- [INI meetings](#)
- [LOS: Legenda o sidlání](#)
- [Opravy v Ceske](#)
- [Krumlovi](#)
- [Nocni Cesky Krumlov](#)
- [EEP_2014](#)
- [Semestr SVU 2014](#)
- [Druzstevni publikace](#)
- [komiksu](#)
- [Navrh](#)
- [Ceskoslovenskeho pavilonu](#)
- [Silná káva v Berlíně](#)
- [Zavazna mana](#)
- [Subconscious educative manual](#)
- [Tribute to Instructions](#)
- [Waveform: Video to](#)
- [Volta](#)
- [Modely pri](#)
- [\(Dis\)harmon](#)
- [Kiosk pro A ja](#)
- [recherche de la bohème](#)
- [perdue](#)
- [Gallery Ducato](#)

past | minulost

- [Průhledná tajemství](#)
- [Transparent Secret](#)
- [publikace KIOSK](#)



Galerie Ducato / Gallery Ducato

Galerii **Ducato** je mozne zaparkovat a premenit ve vystavni prostor behem kratkeho casu. Je otevrena vsem lidem, kteri maji chut vystoupit ze zabehleho koloritu vystavni praxe. Neomezuje se formou vystavovani. Prinasí moznost spoluprace s jinou galerii. Umoznuje dopravu 8 osob a potrebneho materialu na urcene místo. Zajistuje technicke (zobrazovací technika, baterie, menice 12V – 220V, reproduktory, projektory, bezdratovy internet) a provozni zázemí (zabezpečení proti poskození deštěm, uskladnění). Ducato prinasí vřelejší, lidstejší, lidovejší a akcni způsob vystavení. Galerie muze pracovat v ruznych modech (antivystava, symbioza s jinou galerii). Vystavene prace mohou byt virtualni i hmotne.

///



Gallery **Ducato** can be parked and turned into a gallery space within a short time. The Gallery is open to all people, who feel they want to stray from the usual atmosphere of the "Gallery" experience. It brings the possibility of cooperation with other galleries. It provides transportation for up to 8 persons and the necessary materials to a designated place. It has technical (digital frames, battery, 12V-220V converter, speakers, projector, wi-fi) and operational facilities (protection from rain and weather, providing storage). Ducato offers a more warm, human, and people orientated, action-packed means of exhibiting. The Gallery can work in different modes, such as an anti-exhibition, or symbiotic with another gallery. Exhibited works may be either virtual or physical.

[DOWNLOAD >>>Gallery Ducato PDF info.pdf](#)

[Ducato web](#)

///



[Ducato gallery at Poznan's Arsenalia 2012](#) from [Culture Capture](#) on [Vimeo](#).



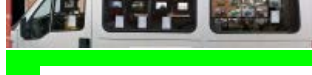





Utopie pro kazdy den

future | budoucnost

- IT Trojan Tactic
- Studio
- TRUE IS: WHERE
- TRASH IS:
- 25 Forgotten Buildings
- bar at Great Wall
- Factory for the Absolute
- Dirty paintings
- Hair Interns
- Individualised Food
- Weapons
- ISO Cafe
- Potatoe Season
- Oslavna rec, Speech
- Periscope out of scrap
- CCTV cameras
- Repair kiosk in
- Amsterdam
- Freedom free-doom
- solidarnosc clip
- IAU in ZK/U
- Kiosk v penzionu
- odlozeneho umeri
- Peripheral knowledge
- INI meetings
- LOS Legenda o sidlisti
- Opravy v Ceskem
- Krumlovi
- Nocni Cesky Krumlov
- KEP_2014
- Semestr SVU 2014
- Druzstevni publikace
- komiksu
- Navrh
- Ceskoslovenskeho
- pavilonu
- Silna kava v Berlina
- Zavarena mena
- Subconscious educative
- manua
- Tribute to instructions
- Waveform, Video to
- Volts
- Modely pro
- (Dis)harmon
- Kiosk pro A la
- recherche de la boheme
- perdue
- Gallery Ducate

past | minulost

Pruhledna tajemstvi |



Pruhledná tajemství AVU.
Laser tisk na pauzovací papír, light box.



Text



Utopie pro kazdy den

future | budoucnost

- IT Trojan Tactics
- Studio
- TRUE IS: WHERE
- TRASH IS:
- 25 Forgotten Buildings
- bar at Great Wall
- Factory for the Absolute
- Dirty paintings
- Hair Interna
- Individualised Food
- Weapons
- ISO Cafe
- Potatoe Season
- Oslavna rec „Speech
- Periscope out of scrap
- CCTV cameras
- Repair kiosk in
- Amsterdam
- Freedom free-doom
- solidarnosc clip
- IAU in ZK/U
- Kiosk v penzionu
- odlozeneho umeri
- Peripheral knowledge
- INI meetings
- LOS Legenda o sidlisti
- opravy v Ceskem
- Krumlov
- Nocni Cesky Krumlov
- REP_2014
- Semestr SVU 2014
- Druzstevni publikace
- komiksu
- Navrh
- Ceskoslovenskeho
- pavilonu
- Silna kava v Berlino
- Zavarena mena
- Subconscious educative
- manua
- Tribute to instructions
- Waveform_Video to
- Voits
- Modely pro
- (Dis)harmon
- Kiosk pro A la
- recherche de la boheme
- perdue
- Gallery Ducate

past | minulost

Prhledna tajemstvi |



Text

58 stran

manifest krehké architektury

Jsou improvizované.
 Jsou ošklivé.
 Jsou lehce znicitelné.
 Jsou barevné.
 Jsou lidské.
 Jsou levné.
 Jsou provokativní.
 Jsou levicové.
 Jsou nekonvenční.
 Jsou nechtené.
 Jsou tolerované.
 Krehké budovy jsou stavby, které existují v primém protikladu k nelidsky dokonalým a honosným palácům ze skla, oceli a kovu.
 Krehké budovy leží většinou v zajímavých částech mesta s nádechem rozvratu, ale i svobody.
 Slouží denní potrebe jako rychlá obcerstvení, novinové stánky, prodejny zeleniny a ovoce nebo jako nálevny a putyky.

manifest mastných stánku

Jsou improvizované.
 Jsou ošklivé.
 Jsou lehce znicitelné.
 Jsou barevné.
 Jsou lidské.
 Jsou levné.
 Jsou provokativní.
 Jsou levicové.
 Jsou nekonvenční.
 Jsou nechtené.
 Jsou tolerované.
 Mastné budovy jsou stavby, které existují v primém protikladu k nelidsky dokonalým a honosným palácům ze skla, oceli a kovu.
 Mastné budovy leží většinou v zajímavých částech mesta s nádechem rozvratu, ale i svobody.
 Slouží denní potrebe jako rychlá obcerstvení, novinové stánky, prodejny zeleniny a ovoce nebo jako nálevny a putyky.



Utopie pro kazdy den

future | budoucnost

- IT Trojan Tactic
- Studio
- TRUE IS: WHERE
- TRASH IS:
- 25 Forgotten Buildings
- bar at Great Wall
- Factory for the Absolute
- Dirty paintings
- Hair Internat
- Individualised Food
- Weapons
- ISO Cafe
- Potatoe Season
- Oslavna rec, Speech
- Periscope out of scrap
- CCTV cameras
- Repair kiosk in
- Amsterdam
- Freedom free-doom
- solidarnosc clip
- IAU in ZK/U
- Kiosk v penzionu
- odlozeneho umeri
- Peripheral knowledge
- INI meetings
- LOS Legenda o sidlisti
- Opravy v Ceskem
- Krumlovi
- Nocni Cesky Krumlov
- EEP 2014
- Semestr SVU 2014
- Druzstevni publikace
- komiksu
- Navrh
- Ceskoslovenskeho
- pavilonu
- Silna kava v Berlino
- Zavarena mena
- Subconscious educative
- manua
- Tribute to instructions
- Waveform, Video to
- Volts
- Modely pro
- (Dis)harmon
- Kiosk pro A la
- recherche de la boheme
- perdue
- Gallery Ducate

past | minulost

Prhledna tajemstvi |



Text

Two very young artists are travelling across the Baltic countries, in quest of both human and natural landscapes. Aleksis Cavaillez, the author of the texts and drawings, is French and has been deaf since he was 5 years old. His road companion, Viktor Vejvoda, is a Czech photographer. To communicate, beside the few words of English they share, Aleksis and Viktor use the full range of visual language: hands, face expressions, drawings, photographs. And this language appears to be also very effective to describe three misrecognized countries of the former Soviet Union and now in Europe.

[Via Baltica on Amazon](#)



Utopie pro kazdy den

future | budoucnost

- IT Trojan Tactic
- Studio
- TRUE IS: WHERE
- TRASH IS:
- 25 Forgotten Buildings
- bar at Great Wall
- Factory for the Absolute
- Dirty paintings
- Hair Interna
- Individualised Food
- Weapons
- ISO Cafe
- Potatoe Season
- Oslavna rec. Speech
- Periscope out of scrap
- CCTV cameras
- Repair kiosk in
- Amsterdam
- Freedom free-doom
- solidarnosc clip
- IAU in ZK/U
- Kiosk v penzionu
- odlozeneho umeri
- Peripheral knowledge
- INI meetings
- LOS Legenda o sidlisti
- Opravy v Ceskem
- Krumlovi
- Nocni Cesky Krumlov
- EEP 2014
- Semestr SVU 2014
- Druzstevni publikace
- komiksu
- Navrh
- Ceskoslovenskeho
- pavilonu
- Silna kava v Berlina
- Zavarena mena
- Subconscious educative
- manua
- Tribute to instructions
- Waveform. Video to
- Volts
- Modely pro
- (Dis)harmon
- Kiosk pro A la
- recherche de la boheme
- perdue
- Gallery Ducate

past | minulost

Pruhledna tajemstvi |



Text

Pictures in the Dark

Idea to realise "Pictures in the Dark" comes from interest into possibility to share and transmit visual information or piece in different way. I was also wondering how to merge transmitted information with surrounding environment so the outcome is original piece. Step by step I came to an act of transmitting picture through sound and backward recording of transmitted sound together with local noises and through spectral analysis obtaining again picture but modified. Because in the form of sound is meaning of coded picture quite latent I am thinking of transmitting sound in public space (radio transmitter) or into space (laser). Giving chance to encode latent meaning to anyone who receives this.

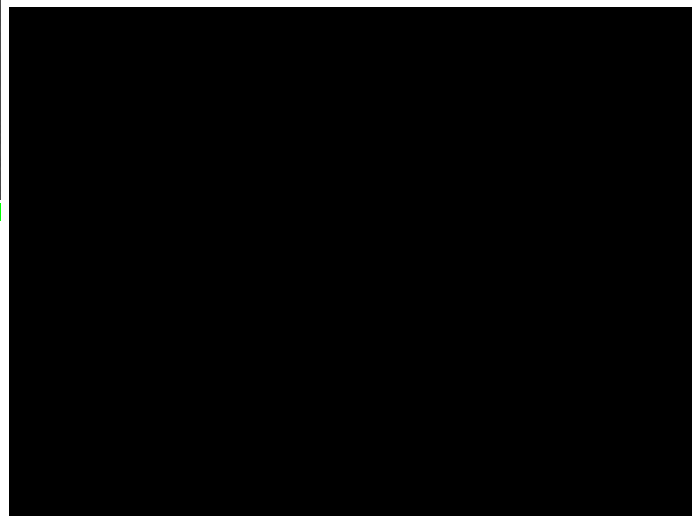

Untitled from Viktor x Utopie on Vimeo.



Utopie pro kazdy den

future | budoucnost

- IT Trojan Tactic
- Studio
- TRUE IS WHERE
- TRASH IS
- 25 Forgotten Buildings
- bar at Great Wall
- Factory for the Absolute
- Dirty paintings
- Hair Internat
- Individualised Food
- Weapons
- ISO Cafe
- Potatoe Season
- Oslavna rec, Speech
- Periscope out of scrap
- CCTV cameras
- Repair kiosk in
- Amsterdam
- Freedom free-doom
- solidarnosc clip
- IAU in ZK/U
- Kiosk v penzionu
- odlozeneho umeri
- Peripheral knowledges
- INI meetings
- LOS Legenda o sidlisti
- Opravy v Ceskem
- Krumlovi
- Nocni Cesky Krumlov
- EEP 2014
- Semestr SVU 2014
- Druzstevni publikace
- komiksu
- Navrh
- Ceskoslovenskeho
- pavilonu
- Silna kava v Berlina
- Zavarena mena
- Subconscious educative
- manual
- Tribute to instructions
- Waveform, Video to
- Volts
- Modely pro
- (Dis)harmon
- Kiosk pro A la
- recherche de la boheme
- perdue
- Gallery Ducato

past | minulost

- Pruhledna tajemstvi



B for Bike

Longer term project. Aimed to material thing such a bike is. I want to promote another point of transportation to larger amount of people around me. As I experienced by changing of tool I can get complete different results. The change of perception of a landscape and its details was significant. Personally the effect was as high as If one would start to look at the objects around him using hands instead of eye. In order to explore tools function in society (bikes function), I have chosen most odd, unneeded and outdated bike, which you can find for free in scrap metal or buy for about 10 euro. Than I began to promote drastically bike to everyone around me, showing pictures made in style of product photography, writing about it and also giving my personal example by using the bike and going on it everywhere as much as possible. It was remarkable to observe how these primitive strategies of advertisement works in real life and how bike is being step by step promoted to near people. Finally we made international trip through Germany to ex-DDR beaches. It was interesting also to compare reaction of people to our transportation tools. In bigger Czech cities was reaction neutral and tolerant in opposition to Czech countryside where we got sometimes negatively commented as riding something socially unacceptable. Or we were target of silly jokes of sort like "My grandma was riding this".



In Germany we were mostly not commented at all even in small towns. In some places were bikes evoking nostalgia connected to years around 1980. In some countryside regions of both countries we have also met such a bikes.



Counting them on a way Prague – North Sea we have come to number 17.

Text



Utopie pro kazdy den

future | budoucnost

- [IT Trojan Tactic](#)
- [Studio](#)
- [TRUE IS: WHERE](#)
- [TRASH IS:](#)
- [25 Forgotten Buildings](#)
- [bar at Great Wall](#)
- [Factory for the Absolute](#)
- [Dirty paintings](#)
- [Hair Internat](#)
- [Individualised Food](#)
- [Weapons](#)
- [ISO Cafe](#)
- [Potatoe Season](#)
- [Oslavna rec... Speech](#)
- [Periscope out of scrap](#)
- [CCTV cameras](#)
- [Repair kiosk in](#)
- [Amsterdam](#)
- [Freedom free-doom](#)
- [solidarnosc clip](#)
- [IAU in ZK/U](#)
- [Kiosk v penzionu](#)
- [odlozeneho umeri](#)
- [Peripheral knowledge](#)
- [INI meeting](#)
- [LOS Legenda o sidlisti](#)
- [Opravy v Ceskem](#)
- [Krumlovi](#)
- [Nocni Cesky Krumlov](#)
- [KEP 2014](#)
- [Semestr SVU 2014](#)
- [Druzstevni publikac](#)
- [komiksu](#)
- [Navrh](#)
- [Ceskoslovenskeho](#)
- [pavilonu](#)
- [Silna kava v Berlino](#)
- [Zavarena mena](#)
- [Subconscious educative](#)
- [manua](#)
- [Tribute to instructions](#)
- [Waveform. Video to](#)
- [Volts](#)
- [Modely pro](#)
- [\(Dis\)harmon](#)
- [Kiosk pro A la](#)
- [recherche de la boheme](#)
- [perdue](#)
- [Gallery Ducate](#)

past | minulost

- [Prhledna tajemstvi](#)



East beats West | 1:0

My authorial book summarizing inspection trips to Eastern countries. Countries which were inspected were Romania, Ukraine and Bulgaria. I wanted to produce publication standing in completely opposition to Tourist guides. Trips were completely unplanned and chaotic in way of its schedule. There for I was always visiting unexpected localities. The rule of chaos created original point of view on each country. Somehow chaos helped to obtain experiences from very particular places which were not mentioned in any accessible tourist guide or information sheet. In book text I reflected assumption about sharp difference between places they were released in any kind of media and places which stay unknown. Other topics are: train as a social institution, caffeine the most spread drug, waste policy of west...



[East beats West | 1:0 | FULL DOWNLOAD PDF](#)



Text



Utopie pro kazdy den

future | budoucnost

- IT Trojan Tactic
- Studio
- TRUE IS: WHERE
- TRASH IS:
- 25 Forgotten Buildings
- bar at Great Wall
- Factory for the Absolute
- Dirty paintings
- Hair Interna
- Individualised Food
- Weapons
- ISO Cafe
- Potatoe Season
- Oslavna rec, Speech
- Periscope out of scrap
- CCTV cameras
- Repair kiosk in
- Amsterdam
- Freedom free-doom
- solidarnosc clip
- IAU in ZK/U
- Kiosk v penzionu
- odlozeneho umeri
- Peripheral knowledge
- INI meetings
- LOS Legenda o sidlisti
- Opravy v Ceskem
- Krumlovi
- Nocni Cesky Krumlov
- EEP 2014
- Semestr SVU 2014
- Druzstevni publikace
- komiksu
- Navrh
- Ceskoslovenskeho
- pavilonu
- Silna kava v Berlina
- Zavarena mena
- Subconscious educative
- manua
- Tribute to instructions
- Waveform, Video to
- Volts
- Modely pro
- (Dis)harmon
- Kiosk pro A la
- recherche de la boheme
- perdue
- Gallery Ducate

past | minulost

Pruhledna tajemstvi |

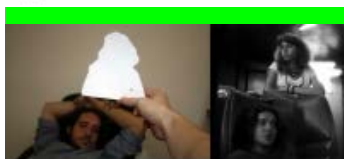

And she disappeared | Flash cut

Everyone has in life some people or elements they slowly vanish out of ones life. To depict those, who left my life I used brutal flash exposure, which burned RGB values up to: R: 255, G: 255, B: 255 (pure white). Uncovering tricky character of photography I used small paper silhouettes to flash on. What would not be possible in real life (for example cover huge house with paper to hide it) it's really simple if photo camera is used. I was amazed by violent possibilities of modifying photographs scene standing in contrast to sneaky Photoshop editing used in most cases. Light can tear in parts!

Text



Utopie pro kazdy den

future | budoucnost

- IT Trojan Tactic
- Studio
- TRUE IS WHERE
- TRASH IS
- 25 Forgotten Buildings
- bar at Great Wall
- Factory for the Absolute
- Dirty paintings
- Hair Interna
- Individualised Food
- Weapons
- ISO Cafe
- Potatoe Season
- Obama rec. Speech
- Periscope out of scrap
- CCTV cameras
- Repair kiosk in
- Amsterdam
- Freedom free-doom
- solidarnosc clip
- IAU in ZK/U
- Kiosk v penzionu
- odlozeneho umeri
- Peripheral knowledge
- INI meetings
- LOS Legenda o sidlisti
- Opravy v Ceskem
- Krumlovi
- Nočni Cesky Krumlov
- REP-2014
- Semestr SVU 2014
- Druzstevni publikace
- komiks
- Navrh
- Ceskoslovenskeho
- pavilonu
- Silna kava v Berlina
- Zavarena mena
- Subconscious educative
- manual
- Tribute to instructions
- Waveform. Video to
- Volts
- Modely pro
- (Dis)harmon
- Kiosk pro A la
- recherche de la boheme
- perdue
- Gallery Ducato

past | minulost

- Pruhledna tajemství |
- Transparent Secret
- publikace KIOSK



Text

Light

Idea which is meant to be realized in landscape in Prague neighbourhood. First I'm going to describe how I came to this theme:
 1st I was thinking about short amateur movie of my friend. It was just usual movie from some party. But all people there were strange frozen and facing like zombies. I realized it was because he was filming with Photo-camera with possibility of shooting movie. But everyone was expecting he is taking picture. So from here comes this rigidity!
 2nd It often happen to me during watching some movie, I imagine what is going on behind camera. I see best boy, camera operators, and people throwing chickens into scene (in Western) or pieces of material (blow up scene). These thought can be really disturbing.
 3rd I like flash. It's small and it makes light. But I never had seen flash as a main object of photograph. Well sometimes in sport photography you can see pieces of flash stands and reflections. But that's all. My goal is to bring photoflash into centre of interest of camera. (And best video camera not photo camera to use this cross tool effect (the freezing people in front of camera, photography flash in video footage)

So finally I would like to build autonomous flash unit out of some trash. It would be necessary to program it and be able to produce them in amount of at least 10 pieces. This unit must be possible to synchronize and I'm thinking also about mode, which flash unit, when human is standing near to. (Something like light mine)

Application of units would be as I said in open space. I have in my mind two light scenarios for nature.

Airport. Would be timed flashes in space, evoking airport. Airport symbolizing nearly military organized object with antiseptically atmosphere. Full of rules and prohibitions. Equipped with CCTV cameras watching everything. And allowing flying away just the ones who have all papers in order and have enough financial resources to afford ticket. Because one human has had always dream of flying and of freedom I would build my own toy airport in fields. It would flash as well as real runway. This act has for me subversive idea and parody content. But it's also connected to famous interpretations of western tools by primitive nations in equatorial areas.

Flash cut is second usage of flash tool. Using flash as an object seems to me like act of transposition. To see, what is supposed to be hidden. (Same experience I have seeing rabbits furs, killed by my grandfather, drying with fur inwards and pink skin outwards) It would make just one striking flash line into landscape. Cutting light parts out of dark. For me light symbolize illumination, enlightening as well as light from blow, police flash bang. All this I would like to bring to attention of camera. In movie would meet principal of movie (continuous catching of action) with principal of photo (in this case on huge light in landscape). The light would be small artificial lightning, if everything works well.

This work symbolise for me non-violent form of subversive action. Flash is archetypically connected to photography as a tool which helps to light up what is being photographed. I'm using flash (more precisely light by itself) as an object in front of cameras.

As an object of interest. Light emitted by light units means for me representation of wild energy. Experience of such a light blow can be described as an experience with natural energy such a lightning or in mythological way as energy to clean up mind or even enlightenment energy. But it is also possible to perceive such a light explosions as an icon for negative energy created by human kind (explosions, police anti-riots flash bangs). Recorded flash also tears visual image of place into something different and shows hidden points of view. Such a light blow is gesture in open space, which tears reality into 2parts (before -after) and can be perceived from far distance with different interpretations by the viewer.

Group of 10 light units. Units are able to emit strong beams of light. Every unity consists of flash tube, electronic controller and battery. Units also contain of capacitor which charge up to 330 volts. Because of this units should be manipulated with care, by informed person. Control is maintained by wire, which is plugged into each of the unit. System is possible to connect to detector of movement. Version of Light 1.2 should be able to emit time programmed light beams. Beam is strong enough to be visible from far distance or from airplane flying in low altitude. Although emitted light is strong, it's not able harm human eye sight. But long and near exposure by the light is not recommended.

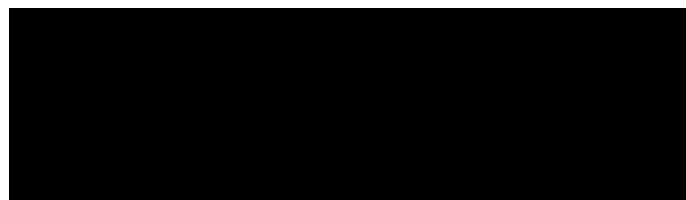



Sv?Ho. Light from Viktor z Utopie on Vimeo.



Utopie pro kazdy den

future | budoucnost

IT Trojan Tactic
Studio
TRUE IS: WHERE
TRASH IS
25 Forgotten Buildings
bar at Great Wall
Factory for the Absolute
Dirty paintings
Hair Internat
Individualised Food
Weapons
ISO Cafe
Potatoe Season
Oslavna rec, Speech
Periscope out of scrap
CCTV cameras
Repair kiosk in
Amsterdam
Freedom free-doom
solidarnosc clip
IAU in ZK/U
Kiosk v penzionu
odlozeneho umeri
Peripheral knowledge
INI meetings
LOS Legenda o sidlisti
Opravy v Ceskem
Krumlovi
Nocni Cesky Krumlov
EEP 2014
Semestr SVU 2014
Druzstevni publikace
komiksu
Navrh
Ceskoslovenskeho
pavilonu
Silna kava v Berlina
Zavarena mena
Subconscious educative
manua
Tribute to instructions
Waveform, Video to
Volts
Modely pro
(Dis)harmon
Kiosk pro A la
recherche de la boheme
perdue
Gallery Ducate

past | minulost

Prhledna tajemstvi |



Text

Things around me

Quotations of things happening around me.
Frozen and packed into A4 paper.

**Rozšlápnutá hranolka na cestě tam.
Rozšlápnutá hranolka na cestě zpátky.**
12.12.2009, Mustek

Ten toustový chleba tam nekde musí být.
19.1.2010, Kamenická / 12:52

Nedávej pusu tomu sedadlu.
26.1.2010, Pavelkova / 20:32

More, kdybych mel internet, tak už si s ní píšu.
5.4.2010, I.P. Pavlova / 19:30



Utopie pro kazdy den

future | budoucnost

- IT Trojan Tactic
- Studio
- TRUE IS: WHERE
- TRASH IS:
- 25 Forgotten Buildings
- bar at Great Wall
- Factory for the Absolute
- Dirty paintings
- Hair Internat
- Individualised Food
- Weapons
- ISO Cafe
- Potatoe Season
- Oslavna rec. Speech
- Periscope out of scrap
- CCTV cameras
- Repair kiosk in
- Amsterdam
- Freedom free-doom
- solidarnosc clip
- IAU in ZK/U
- Kiosk v penzionu
- odlozeneho umeri
- Peripheral knowledge
- INI meetings
- LOS Legenda o sidlisti
- Opravy v Ceskem
- Krumlovi
- Nocni Cesky Krumlov
- EEP 2014
- Semestr SVU 2014
- Druzstevni publikace
- komiksu
- Navrh
- Ceskoslovenskeho
- pavilonu
- Silna kava v Berlina
- Zavarena mena
- Subconscious educative
- manua
- Tribute to instructions
- Waveform. Video to
- Volts
- Modely pro
- (Dis)harmon
- Kiosk pro A la
- recherche de la boheme
- perdue
- Gallery Ducate

past | minulost

Pruhledna tajemstvi |



Text

Tracked T-shirt

I observed a second hand clothing market in Czech and compared it with donations to charity in the West. I came to conclusion that part of clothes is being collected as a charity in Western countries and than transferred to East, where clothes are sold in second hand shops with profit. I believe this market is well organized and covered by infrastructure of some kind of organisation. I was haunting for some traces in pockets, but only thing I have ever found was a franc coin in corduroy trousers a year ago. Trace is that on lot second hand sold clothes are missing brands. Mostly they are professionally removed. I believe, it would be possible to uncover whole system of such a market by finding first owner with help of social network and re-compose history of particular cloth. I hope so, because some brands are specific and worn by quiet small social groups. Project also aim on fact that things which are in one place evaluate as unwanted, old-fashioned, worn out and are in other places sold again and used for some more time. Also total amount of financial spend for every piece of cloth is growing (original price + second hand price) which leads to interesting money flows.



Laser cut

Laser ray long 566m. Source of laser was taken out of DVD burner. It create visual cut into ordinary daily view.

Text

Utopie pro kazdy den

future | budoucnost

- IT Trojan Tactic
- Studio
- TRUE IS: WHERE
- TRASH IS.
- 25 Forgotten Buildings
- bar at Great Wall
- Factory for the Absolute
- Dirty paintings
- Hair Internat
- Individualised Food
- Weapons
- ISO Cafe
- Potatoe Season
- Oslavna rec. Speech
- Periscope out of scrap
- CCTV cameras
- Repair kiosk in
- Amsterdam
- Freedom free-doom
- solidarnosc clip
- IAU in ZK/U
- Kiosk v penzionu
- odlozeneho umeri
- Peripheral knowledges
- INI meetings
- LOS Legenda o sidlisti
- Opravy v Ceskem
- Krumlovi
- Nocni Cesky Krumlov
- KEP_2014
- Semestr SVU 2014
- Druzstevni publikace
- komiksu
- Navrh
- Ceskoslovenskeho
- pavilonu
- Silna kava v Berlina
- Zavarena mena
- Subconscious educative
- manua
- Tribute to instructions
- Waveform. Video to
- Volts
- Modely pro
- (Dis)harmon
- Kiosk pro A la
- recherche de la boheme
- perdue
- Gallery Ducate

past | minulost

- Prhledna tajemstvi |



Utopie pro kazdy den

future | budoucnost

- IT Trojan Tactics Studio
- TRUE IS: WHERE
- TRASH IS:
- 25 Forgotten Buildings
- bar at Great Wall
- Factory for the Absolute
- Dirty paintings
- Hair Interns
- Individualised Food
- Weapons
- ISO Cafe
- Potatoe Season
- Oslavna rec, Speech
- Periscope out of scrap
- CCTV cameras
- Repair kiosk in Amsterdam
- Freedom free-doom
- solidarnosc clip
- IAU in ZK/U
- Kiosk v penzionu
- odlozeneho umeri
- Peripheral knowledge
- INI meetings
- LOS Legenda o sidlisti
- Opravy v Ceskem
- Krumlovi
- Nocni Cesky Krumlov
- EEP_2014
- Semestr SVU 2014
- Druzstevni publikace
- komiksu
- Navrh
- Ceskoslovenskeho
- pavilonu
- Silna kava v Berlina
- Zavarena mena
- Subconscious educative
- manua
- Tribute to instructions
- Waveform, Video to
- Volts
- Modely pro
- (Dis)harmon
- Kiosk pro A la
- recherche de la boheme
- perdue
- Gallery Ducate

past | minulost

Pruhledna tajemstvi



253

2min 53sec. video in bus 253 of swearing man, who is not visible at all.



Text

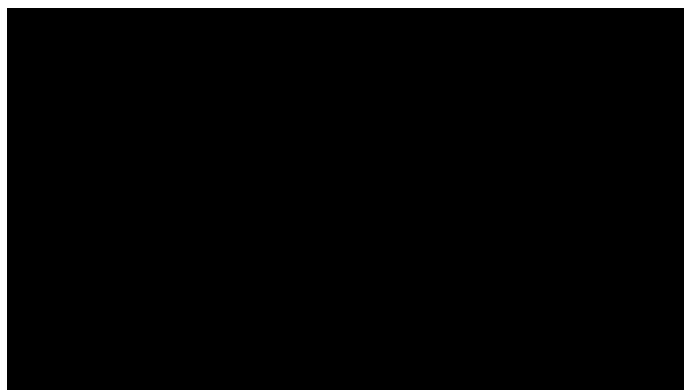

253 from Viktor z Utopie on Vimeo.



Utopie pro kazdy den

future | budoucnost

- IT Trojan Tactic
- Studio
- TRUE IS: WHERE
- TRASH IS.
- 25 Forgotten Buildings
- bar at Great Wall
- Factory for the Absolute
- Dirty paintings
- Hair Internat
- Individualised Food
- Weapons
- ISO Cafe
- Potatoe Season
- Oslavna rec, Speech
- Periscope out of scrap
- CCTV cameras
- Repair kiosk in
- Amsterdam
- Freedom free-doom
- solidarnosc clip
- IAU in ZK/U
- Kiosk v penzionu
- odlozeneho umeri
- Peripheral knowledges
- INI meetings
- LOS Legenda o sidlisti
- Opravy v Ceskem
- Krumlovi
- Nocni Cesky Krumlov
- KEP_2014
- Semestr SVU 2014
- Druzstevni publikace
- komiksu
- Navrh
- Ceskoslovenskeho
- pavilonu
- Silna kava v Berlina
- Zavarena mena
- Subconscious educative
- manua
- Tribute to instructions
- Waveform, Video to
- Volts
- Modely pro
- (Dis)harmon
- Kiosk pro A la
- recherche de la boheme
- perdue
- Gallery Ducate

past | minulost

Pruhledna tajemstvi |



Text

Small animals

Night shot of haunting small animals in suburb area.

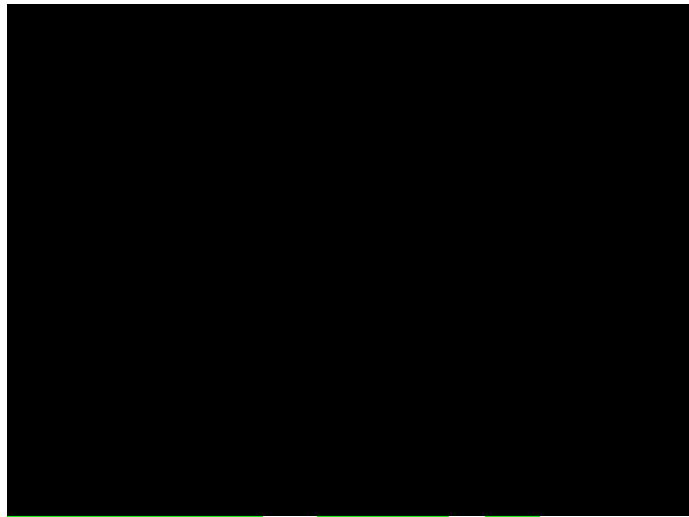

Mala zvir?ata | Small Animals | from Viktor z Utopie on Vimeo.



Utopie pro kazdy den

future | budoucnost

- IT Trojan Tactic
- Studio
- TRUE IS: WHERE
- TRASH IS:
- 25 Forgotten Buildings
- bar at Great Wall
- Factory for the Absolute
- Dirty paintings
- Hair Internat
- Individualised Food
- Weapons
- ISO Cafe
- Potatoe Season
- Oslavna rec. Speech
- Periscope out of scrap
- CCTV cameras
- Repair kiosk in
- Amsterdam
- Freedom free-doom
- solidarnosc clip
- IAU in ZK/U
- Kiosk v penzionu
- odlozeneho umeri
- Peripheral knowledge
- INI meeting
- LOS Legenda o sidlisti
- Opravy v Ceskem
- Krumlovi
- Nocni Cesky Krumlov
- EEP 2014
- Semestr SVU 2014
- Druzstevni publikace
- komiksu
- Navrh
- Ceskoslovenskeho
- pavilonu
- Silna kava v Berlina
- Zavarena mena
- Subconscious educative
- manua
- Tribute to instructions
- Waveform Video to
- Volts
- Modely pro
- (Dis)harmon
- Kiosk pro A la
- recherche de la boheme
- perdue
- Gallery Ducato

past | minulost

Prhledna tajemstvi |



Text

Soy Wall

I bought bottle of soy sauce. Tasting it, brought my mind to question about interpretation of others culture in home culture. How and what are we imagining about countries and people far away from place where we live. Are we having realistic point of view or is all we tend to imagine just fiction? Are food rituals which we connect with other cultures and we practise theme in Europe just as well fictive? What is real reality? And for whom is reality more real and for whom less.

Project is based on long discussions about China with European traveller. (which is also raising question if tourism or travelling can bring overview on different cultures at all, in case its still just part of GDP and in a way industry.

Piece consisting of: painting (1,5x4m), video interview and GPS navigated land-art installation.

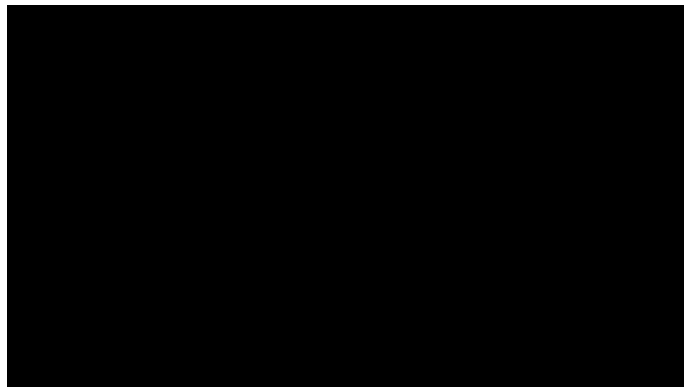

Sojova ze? | Soy Wall from Viktor z Utopie on Vimeo.



Utopie pro kazdy den

future | budoucnost

- IT Trojan Tactic
- Studio
- TRUE IS: WHERE
- TRASH IS:
- 25 Forgotten Buildings
- bar at Great Wall
- Factory for the Absolute
- Dirty paintings
- Hair Interns
- Individualised Food
- Weapons
- ISO Cafe
- Potatoe Season
- Oslavna rec, Speech
- Periscope out of scrap
- CCTV cameras
- Repair kiosk in
- Amsterdam
- Freedom free-doom
- solidarnosc clip
- IAU in ZK/U
- Kiosk v penzionu
- odlozeneho umeri
- Peripheral knowledges
- INI meetings
- LOS Legenda o sidlisti
- Opravy v Ceskem
- Krumlovi
- Nocni Cesky Krumlov
- KEP_2014
- Semestr SVU 2014
- Druzstevni publikace
- komiksu
- Navrh
- Ceskoslovenskeho
- pavilonu
- Silna kava v Berlina
- Zavarena mena
- Subconscious educative
- manua
- Tribute to instructions
- Waveform, Video to
- Volts
- Modely pro
- (Dis)harmon
- Kiosk pro A la
- recherche de la boheme
- perdue
- Gallery Ducato

past | minulost

Prhledna tajemstvi |



3 bikes, Brno city, Zbrojovka factory hall and 3 people.
LIFE = CONTENT

Text



Utopie pro kazdy den

future | budoucnost

- IT Trojan Tactic
- Studio
- TRUE IS: WHERE
- TRASH IS:
- 25 Forgotten Buildings
- bar at Great Wall
- Factory for the Absolute
- Dirty paintings
- Hair Internat
- Individualised Food
- Weapons
- ISO Cafe
- Potatoe Season
- Oslavna rec. Speech
- Periscope out of scrap
- CCTV cameras
- Repair kiosk in
- Amsterdam
- Freedom free-doom
- solidarnosc clip
- IAU in ZK/U
- Kiosk v penzionu
- odlozeneho umeri
- Peripheral knowledge
- INI meetings
- LOS Legenda o sidlisti
- Opravy v Ceskem
- Krumlovi
- Nocni Cesky Krumlov
- EEP 2014
- Semestr SVU 2014
- Druzstevni publikace
- komiksu
- Navrh
- Ceskoslovenskeho
- pavilonu
- Silna kava v Berlino
- Zavarena mena
- Subconscious educative
- manua
- Tribute to instructions
- Waveform. Video to
- Volts
- Modely pro
- (Dis)harmon
- Kiosk pro A la
- recherche de la boheme
- perdue
- Gallery Ducate

past | minulost

Pruhledna tajemstvi |



2,5 GHz

Research in invisible sphere of frequency 2,5 GHz. This frequency is determined for wireless network connections. Coverage of landscape and urban areas with these sites are much more frequent with expanding technicalization of society.

I deal with data capturing and interpreting of names and relations of Access points. I pointed my intention to see the life routines (time of on/off mode of AP), minority names of AP's, AP's names with sexual undertone, factory settings of AP's, vulgar AP's names.



Data capturing is made by walking in area of interest. Next possibility of data capturing is train journey.

Outcome of research would be catalogue list of AP with map, from which is possible read context of individual APs.

Realization would be done as a machine cut graphics applied right on place of presentation.



Text



Utopie pro každý den

future | budoucnost

- IT Trojan Tactic
- Studio
- TRUE IS: WHERE
- TRASH IS:
- 25 Forgotten Buildings
- bar at Great Wall
- Factory for the Absolute
- Dirty paintings
- Hair Internat
- Individualised Food
- Weapons
- ISO Cafe
- Potatoe Season
- Oslavna rec. Speech
- Periscope out of scrap
- CCTV cameras
- Repair kiosk in
- Amsterdam
- Freedom free-doom
- solidarnosc clip
- IAU in ZK/U
- Kiosk v penzionu
- odlozeneho umeri
- Peripheral knowledges
- INI meetings
- LOS Legenda o sidlisti
- Opravy v Ceskem
- Krumlovi
- Nocni Cesky Krumlov
- EEP 2014
- Semestr SVU 2014
- Druzstevni publikace
- komiksu
- Navrh
- Ceskoslovenskeho
- pavilonu
- Silna kava v Berlina
- Zavarena mena
- Subconscious educative
- manua
- Tribute to instructions
- Waveform. Video to
- Volts
- Modely pro
- (Dis)harmon
- Kiosk pro A la
- recherche de la boheme
- perdue
- Gallery Ducate

past | minulost

Prhledna tajemstvi



Boty plné vody

Boty plné krve

Boty plné vody

Boty plné lesku



Text



Utopie pro kazdy den

future | budoucnost

- IT Trojan Tactic
- Studio
- TRUE IS: WHERE
- TRASH IS:
- 25 Forgotten Buildings
- bar at Great Wall
- Factory for the Absolute
- Dirty paintings
- Hair Interns
- Individualised Food
- Weapons
- ISO Cafe
- Potatoe Season
- Oslavna rec, Speech
- Periscope out of scrap
- CCTV cameras
- Repair kiosk in
- Amsterdam
- Freedom free-doom
- solidarnosc clip
- IAU in ZK/U
- Kiosk v penzionu
- odlozeneho umeri
- Peripheral knowledge
- INI meetings
- LOS Legenda o sidlisti
- Opravy v Ceskem
- Krumlovi
- Nocni Cesky Krumlov
- EEP 2014
- Semestr SVU 2014
- Druzstevni publikace
- komiksu
- Navrh
- Ceskoslovenskeho
- pavilonu
- Silna kava v Berlina
- Zavarena mena
- Subconscious educative
- manua
- Tribute to instructions
- Waveform, Video to
- Volts
- Modely pro
- (Dis)harmon
- Kiosk pro A la
- recherche de la boheme
- perdue
- Gallery Ducato

past | minulost

Pruhledna tajemstvi |

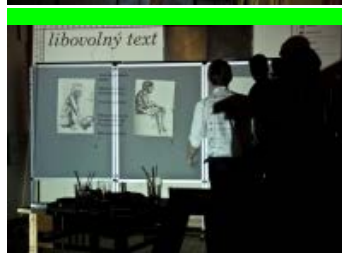

Text

Drawing lesson at AVU

* * *

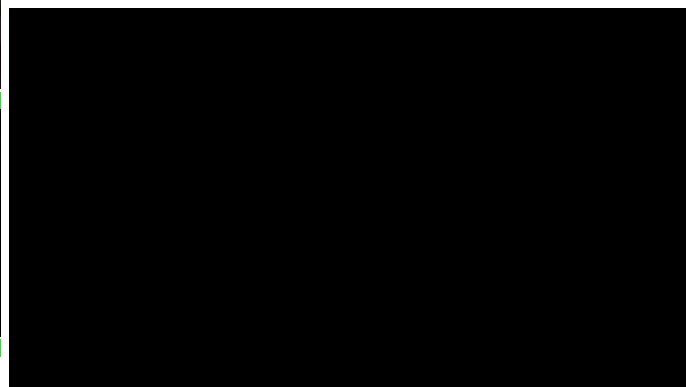

Kresba na AVU | Drawing lesson at AVU from Viktor z Utopie on Vimeo.



Utopie pro kazdy den

future | budoucnost

- IT Trojan Tactic
- Studio
- TRUE IS: WHERE
- TRASH IS:
- 25 Forgotten Buildings
- bar at Great Wall
- Factory for the Absolute
- Dirty paintings
- Hair Internat
- Individualised Food
- Weapons
- ISO Cafe
- Potatoe Season
- Oslavna rec, Speech
- Periscope out of scrap
- CCTV cameras
- Repair kiosk in
- Amsterdam
- Freedom free-doom
- solidarnosc clip
- IAU in ZK/U
- Kiosk v penzionu
- odlozeneho umeri
- Peripheral knowledges
- INI meetings
- LOS Legenda o sidlisti
- Opravy v Ceskem
- Krumlovi
- Nocni Cesky Krumlov
- EEP 2014
- Semestr SVU 2014
- Druzstevni publikace
- komiksu
- Navrh
- Ceskoslovenskeho
- pavilonu
- Silna kava v Berlina
- Zavarena mena
- Subconscious educative
- manua
- Tribute to instructions
- Waveform, Video to
- Volts
- Modely pro
- (Dis)harmon
- Kiosk pro A la
- recherche de la boheme
- perdue
- Gallery Ducate

past | minulost

Pruhledna tajemstvi |

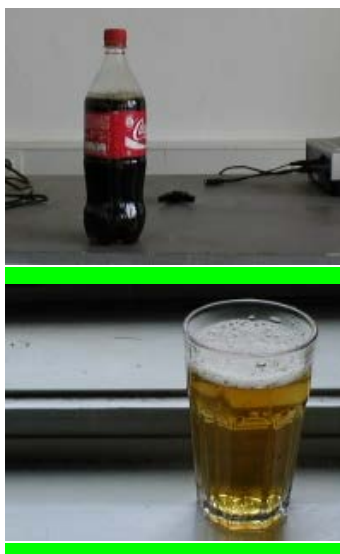

Text

Metabolism | Metabolismus

I have been looking for substances which are similar to other famous materials and can be visually substituted. I was looking for subversive versions of well known reality. Playing with idea of second possibility of existence and order. Looking for parallel order and relations where things are not what we are used to. This twisting is starting with expression on face, of one who find in bottle of famous soda, something different.

///

Hledal jsem takove substance, které jsou podobne s jinymi slavnymi latkami a mohou byt snadno vizualne zamenitelne. Patral jsem po podvratne verzi dobre zname a zabehnuté reality. Hricka s druhou moznosti existence a radu veci. Patrani po alternativnich vztazich a poradku veci, kde vse neni tak, jak jsme uvykli. Prekroucení reality zacina u vyrazu tvare cloveka, který se napije limonady, ale obsah lahve je uplne necim jinym, nez na co vypada.



Utopie pro kazdy den

future | budoucnost

- IT Trojan Tactic Studio
- TRUE IS: WHERE TRASH IS.
- 25 Forgotten Buildings bar at Great Wall
- Factory for the Absolute Dirty paintings
- Hair Internat
- Individualised Food Weapons
- ISO Cafe
- Potatoe Season
- Oslovna rec. Speech
- Periscope out of scrap
- CCTV cameras
- Repair kiosk in Amsterdam
- Freedom free-doom
- solidarnosc clip
- IAU in ZK/U
- Kiosk v penzionu odlozeneho umeri
- Peripheral knowledge
- INI meetings
- LOS Legenda o sidlisti
- Opravy v Ceskem
- Krumlovi
- Nocni Cesky Krumlov
- EEP 2014
- Semestr SVU 2014
- Druzstevni publikace komiksu
- Navrh
- Ceskoslovenskeho pavilonu
- Silna kava v Berlina
- Zavarena mena
- Subconscious educative manual
- Tribute to instructions
- Waveform. Video to
- Volts
- Modely pro
- (Dis)harmon
- Kiosk pro A la
- recherche de la boheme
- perdue
- Gallery Ducate

past | minulost

Pruhledna tajemstvi



Long-distance Call | video loop 3'35"

Mysterious dialogue of author together with ears of a dead man. Sonically is dialogue held on same level of sound as is audio feedback hearable (also known as the Larsen effect after the Danish scientist, Soren Larsen).

speaker	»»»»	microphone
∧	∞	∩
amplifier	«	mixer

Long-distance Call | Dalkovy hovor

Mysterious dialogue of author together with ears of a dead man. Sonically is dialogue held on same level of sound as is audio feedback hearable (also known as the Larsen effect after the Danish scientist, Soren Larsen).

///

Kratke obrazove zamysleni o navazani zahrobniho hovoru. Pri nataceni hovorum s mrtvym muzem, který byl soucasti meho zivota. Navazuji a obnovuji s nim intimni rozhovor. Muz znovu promlouvá na kratkou a mrazivou chvíli do meho a divakova ucha. Kratce na to seance konci. Spojeni se odmlcuje. Kouzelná krabicka je uzavrena. Zvukove je rozhovor zalozen na Larsenovu efektu, který popisuje jev znamy jako echo nebo vazba.

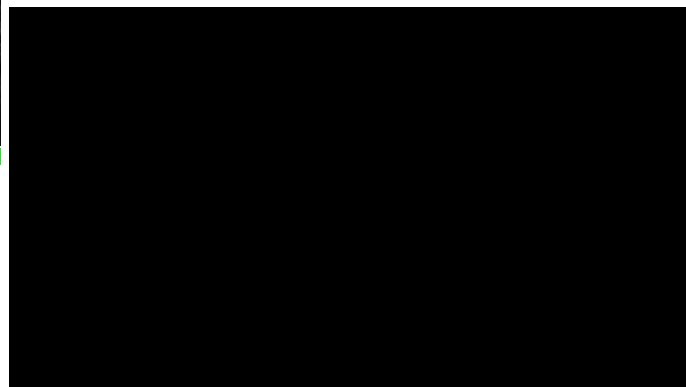

Dalkovy hovor | Long-distance Call from Viktor z Utopie on Vimeo.

Text



Utopie pro kazdy den

future | budoucnost

- IT Trojan Tactic
- Studio
- TRUE IS: WHERE
- TRASH IS:
- 25 Forgotten Buildings
- bar at Great Wall
- Factory for the Absolute
- Dirty paintings
- Hair Internat
- Individualised Food
- Weapons
- ISO Cafe
- Potatoe Season
- Oslovna rec... Speech
- Periscope out of scrap
- CCTV cameras
- Repair kiosk in
- Amsterdam
- Freedom free-doom
- solidarnosc clip
- IAU in ZK/U
- Kiosk v penzionu
- odlozeneho umeri
- Peripheral knowledge
- INI meetings
- LOS Legenda o sidlisti
- Opravy v Ceskem
- Krumlovi
- Nozni Cesky Krumlov
- REP-2014
- Semestr SVU 2014
- Druzstevni publikace
- komiksu
- Navrh
- Ceskoslovenskeho
- pavilonu
- Silna kava v Berlina
- Zavarena mena
- Subconscious educative
- manual
- Tribute to instructions
- Waveform. Video to
- Volts
- Modely pro
- (Dis)harmon
- Kiosk pro A la
- recherche de la boheme
- perdue
- Gallery Ducate

past | minulost

Pruhledna tajemstvi |

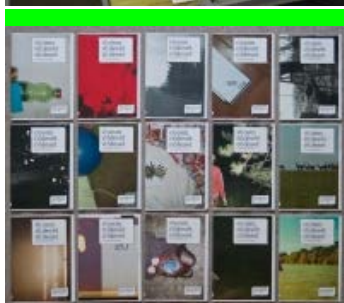

Text

0809010

Project working with photographs of 5 different authors which are systematized into chronological order. Viewer can experience reading on same time level between books of different authors and build up story. Images are no more buried on HDD of their authors, they are materialized and obtain new kind of interactivity, which is not typical for printed medium.

Work is realised by Viktor Vejvoda and Jan Maštera
Invited participants are Adéla Křemplová, Iveta Schovancová and Matej Pavlík.

<http://www.the-low-orbit.net/0809010/>

///

Prace predstavuje soubor 15 knih od peti autoru. Kazdy pripravil podle predem daneho systemu 3 knihy. Kazda kniha prezentuje jeden uplynuly rok (2008, 2009, 2010). Autori hledali ve svem archivu fotografie s konkrétnim datem vzniku, které pak poskladali do „lineárního příběh casu“. Na zaklade predem zvoleneho vzorce a zpusobu prace vsak vznikly samostatne originalni celky v podobe knihy. Projekt zabývající se ctením knihy ne jako celku, ale spis jako fragmentu příběhu. Celistvost a integrita se projevuje az ve chvíli synchronního ctení více knih najednou. Divak ma sancí se setkat s otevrenou formou fotografické sebereflexe. Zivotni obrazy zachycene „stroji na vzpomínky“ jsou vetsinou naveky uveznene na pocitacovych discích. V tistene a hmatatelne publikaci je mozne jejich odrazy znovu zahlednout. V podobe knihy je fotografie verejne dostupnou formou. Z etickeho hlediska je naopak nahlizeni do soukromych dat spise zapovazene. Soucasti vystavy je i poetizující popis ceého projektu. Kazda z knih nese linku jednoho z nas. Linky, radky příběhu se krizi, protínají, rozbíhají, nasledují, provazi i nesouvisi.

Paralelni radky mohou vytvaret nove prostory ke ctení mezi radky.

*Jeden rok je dvanact mesicu.
Tri roky jsou tricet sest mesicu.
Tri roky jsou tri knihy. Jedna kniha je dvanact mesicu.
Tri knihy jsou tricet sest mesicu.
Jedno jmeno jsou tri roky.
Jedna kniha je čtyricet osm stran obrazu.
Jeden mesic jsou čtyri strany.
Jedna strana je casti příběhu.
Prazdna strana neexistuje.
Stejne strany jsou stejne mesice.
Pet jmen je patnact roku.
Pet jmen jsou soubezne příběhy.
000
Radky jsou příběhy jsou strany.*

<http://www.the-low-orbit.net/0809010/>



Utopie pro kazdy den

future | budoucnost

- IT Trojan Tactica
- Studio
- TRUE IS: WHERE
- TRASH IS:
- 25 Forgotten Buildings
- bar at Great Wall
- Factory for the Absolute
- Dirty paintings
- Hair Interna
- Individualised Food
- Weapons
- ISO Cafe
- Potatoe Season
- Oslavna rec, Speech
- Periscope out of scrap
- CCTV cameras
- Repair kiosk in
- Amsterdam
- Freedom free-doom
- solidarnosc clip
- IAU in ZK/Ú
- Kiosk v penzionu
- odlozeneho umeri
- Peripheral knowledge
- INI meetings
- LOS Legenda o sidlisti
- Opravy v Ceskem
- Krumlovi
- Nocni Cesky Krumlov
- KEP 2014
- Semestr SVU 2014
- Druzstevni publikace
- komiksu
- Navrh
- Ceskoslovenskeho
- pavilonu
- Silna kava v Berlino
- Zavarena mena
- Subconscious educative
- manua
- Tribute to instructions
- Waveform, Video to
- Volts
- Modely pro
- (Dis)harmon
- Kiosk pro A la
- recherche de la boheme
- perdue
- Gallery Ducato

past | minulost

Pruhledna tajemstvi |



Meta Code | Meta kod

Text (meta code) of « Image [1st level]
Image (meta code) of « Text [2nd level]

Visual essay about possibility of changing from linear perception to circular perception.
Jumping in one small gesture from linear historical perception of time into circular magical time.

About circular magical time contrary to linear historical time and perception is speaking Vilém Flusser in his essays. And they have been reference for this work.

///

Text (metakod) « Obrazu [1. stupen]
Obraz (metakod) « Textu [2. stupen]

Vizualni esej, ktera pomoci maleho gesta, znazornuje zmenu percepcie casu z linearniho vnimani do vnimani cirkularniho. Tato zmena muze popisovat ruzne odvetvi a zmeny v nasi spolecnosti. Napriklad nazirani na kauzalitu, ale stejne tak mluvi o profannim a magickem pristupu a zaveru, ze oba principy jsou velmi svazany.

Meta Code | video loop 2'41"

Text (meta code) of « Image [1st level]
Image (meta code) of « Text [2nd level]

Visual essay about possibility of changing from linear perception to circular perception.
Jumping in one small gesture from linear historical perception of time into circular magical time.
About circular magical time contrary to linear historical time and perception is speaking Vilém Flusser in his essays. And they have been reference for this work.

okruhovy čas magie ✕ lineární čas historie

Text

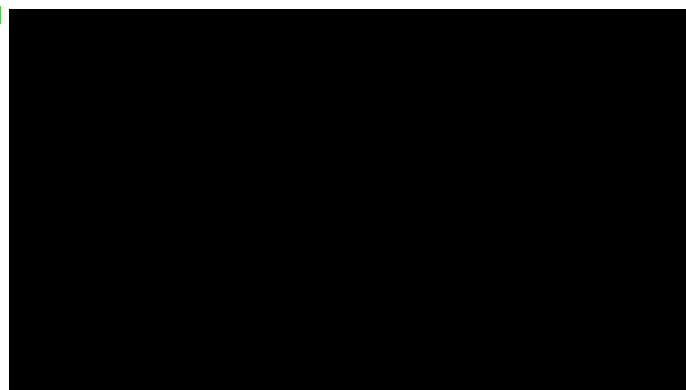

Meta kod | Meta Code from Viktor z Utopie on Vimeo.



 Utopie pro kazdy den

future | budoucnost

- [IT Trojan Tactic](#)
- [Studio](#)
- [TRUE IS: WHERE](#)
- [TRASH IS:](#)
- [25 Forgotten Buildings](#)
- [bar at Great Wall](#)
- [Factory for the Absolute](#)
- [Dirty paintings](#)
- [Hair Interna](#)
- [Individualised Food](#)
- [Weapons](#)
- [ISO Cafe](#)
- [Potatoe Season](#)
- [Oslovna rec, Speech](#)
- [Periscope out of scrap](#)
- [CCTV cameras](#)
- [Repair kiosk in](#)
- [Amsterdam](#)
- [Freedom free-doom](#)
- [solidarnosc clip](#)
- [IAU in ZK/Ú](#)
- [Kiosk v penzionu](#)
- [odlozeneho umeri](#)
- [Peripheral knowledge](#)
- [INI meetings](#)
- [LOS Legenda o sidlisti](#)
- [Opravy v Ceskem](#)
- [Krumlovi](#)
- [Nocni Cesky Krumlov](#)
- [KEP_2014](#)
- [Semestr SVU 2014](#)
- [Druzstevni publikace](#)
- [komiksu](#)
- [Navrh](#)
- [Ceskoslovenskeho](#)
- [pavilonu](#)
- [Silna kava v Berlina](#)
- [Zavarena mena](#)
- [Subconscious educative](#)
- [manua](#)
- [Tribute to instructions](#)
- [Waveform, Video to](#)
- [Volts](#)
- [Modely pro](#)
- [\(Dis\)harmon](#)
- [Kiosk pro A la](#)
- [recherche de la boheme](#)
- [perdue](#)
- [Gallery Ducato](#)

past | minulost

- [Pruhledna tajemstvi](#)



Text

Welded molecule

For this "installation" I would like to synthesize together 3D models of molecules, Welded models of molecules (maybe combined all together [in 3D programme]) and theoretical content of 3 substances: caffeine, hydrocarbon and alcohol. I wish to be able think and work with those molecules in all 3 attitudes as a model in cyberspace, real durable model produced from metal and hypothetical models and relations in my mind. I would be happy if outcome of this idea is place where you can play with my real big welded molecules, place them according one's preferences or warn people in what mood one is. But also in same place read links and facts about these molecules (maybe listen song about them) and finally (in same time) watch 3D outcome as an animation. I like that the chosen molecules symbolize modern-days consumption and speeded-up lifestyle as well as spiritual traditions of more than one culture. If I put carbohydrate in middle (human molecule), on sides I end up with molecule of alcohol typical for Christian Culture and on the other side Caffeine typical for Arabic or far Eastern culture. Carbohydrate plays main role in human body (one of 4 bio molecules) as a transporter of energy (alcohol, coff.) and it is responsible for bloods clotting. Which brings my mind back to bible's quotation: In whom we have salvation through his blood. I'm sure afterwards during work on my topic I can find much more links between these molecules.



Utopie pro kazdy den

future | budoucnost

- IT Trojan Tactic
- Studio
- TRUE IS: WHERE
- TRASH IS:
- 25 Forgotten Buildings
- bar at Great Wall
- Factory for the Absolute
- Dirty paintings
- Hair Internat
- Individualised Food
- Weapons
- ISO Cafe
- Potatoe Season
- Oslavna rec...Speech
- Periscope out of scrap
- CCTV cameras
- Repair kiosk in
- Amsterdam
- Freedom free-doom
- solidarnosc clip
- IAU in ZK/U
- Kiosk v penzionu
- odlozeneho umeri
- Peripheral knowledge
- INI meetings
- LOS Legenda o sidlisti
- Opravy v Ceskem
- Krumlovi
- Nocni Cesky Krumlov
- KEP_2014
- Semestr SVU 2014
- Druzstevni publikace
- komiksu
- Navrh
- Ceskoslovenskeho
- pavilonu
- Silna kava v Berlina
- Zavarena mena
- Subconscious educative
- manua
- Tribute to instructions
- Waveform. Video to
- Volts
- Modely pro
- (Dis)harmon
- Kiosk pro A la
- recherche de la boheme
- perdue
- Gallery Ducate

past | minulost

Prhledna tajemstvi |



Cake! abstract statistics | Kolac! abstraktni statistika

Statistical auto-portrait about value and price with abstract visualization. This work is evaluative question about way how humans work is appreciated. Comparing, counting and lining-up things can lead to interesting abstract outcomes: it's the artist who is most affordable!

In: samizdat style publication printed as outcome of Dan Perjovschih workshop at the Academy of Fine Arts, Prague, 15. 3. - 19. 3. 2011

///



Text

Zamysleni nad proporcemi mezi odvedenou praci a odmenou za ni. Vysledkem mych vypoctu je statisticky autoportret v podobe abstraktni vizualizace. Prekvapive statistika, ktera si klade spolecenske otazky v posunutem uhlu pohledu temer potvrzuje biblickou vetu: „A prvni budou poslednimi a posledni budou prvni.“

In: publikovano jako vystup workshopu s Danem Perjovschim na AVU, Praha, 15. 3. - 19. 3. 2011

[DOWNLOAD >>>Cake! abstract statistics.pdf](#)



Utopie pro kazdy den

future | budoucnost

- [IT Trojan Tactic Studio](#)
- [TRUE IS WHERE TRASH IS](#)
- [25 Forgotten Buildings](#)
- [bar at Great Wall](#)
- [Factory for the Absolute](#)
- [Dirty paintings](#)
- [Hair Internat](#)
- [Individualised Food](#)
- [Weapons](#)
- [ISO Cafe](#)
- [Potatoe Season](#)
- [Oslavna rec, Speech](#)
- [Periscope out of scrap](#)
- [CCTV cameras](#)
- [Repair kiosk in Amsterdam](#)
- [Freedom free-doom](#)
- [solidarnosc clip](#)
- [IAU in ZK/U](#)
- [Kiosk v penzionu odlozeneho umeri](#)
- [Peripheral knowledge](#)
- [INI meeting](#)
- [LOS Legenda o sidlisti](#)
- [Opravy v Ceskem Krumlovi](#)
- [Nocni Cesky Krumlov](#)
- [EEP 2014](#)
- [Semestr SVU 2014](#)
- [Druzstevni publikace komiksu](#)
- [Navrh](#)
- [Ceskoslovenskeho pavilonu](#)
- [Silna kava v Berlina](#)
- [Zavarena mena](#)
- [Subconscious educative manual](#)
- [Tribute to instructions](#)
- [Waveform Video to Voits](#)
- [Modely pro \(Dis\)harmonii](#)
- [Kiosk pro A la recherche de la boheme perdue](#)
- [Gallery Ducate](#)

past | minulost

[Prhledna tajemstvi](#)



Text

Exhumation | Exhumace

Exhumation video is based on criticism and exploration of new media technologies and media critical approach. New technologies have made huge steps in technology evolution. But what happen with human? Are we already not able to understand tools and equipments which we using every day? Is human kind still master or slave of its own technology? As grave robber in Egyptian pyramid I try to discover what kind of treasure is hidden in modern data tombs. What is secret of modern technology crypts? By this time was 9 hard drives exhumed.

///

Balada o snaze nasi civilizace mumifikovat data a uchovat je pro Posledni soud. Video prochazi ruznymi stadii datoveho osudu. K natoceni tohoto datoveho melodramatu jsem pouzil harddisky, které potkal smutny osud, ze informace v nich obsazene sice stale existuji, ale neni jiz mozne je precist. Jsou nezive a nemrtve. Jako archeolog proto vstupuji na uzemi datovych hrobek a prozkoumavam je, ale zaroven je i plnim a nenavratne nicim. Na miste je tedy zamysleni nad otazkou jestli neni nase technokraticka duvera v tyto zarizeni prebujela. Prace je prezentovana jako video instalace. Touto dobou bylo exhumovano 9 pevných disku.



exhumace | Exhumation | || enhanced saga from Viktor z Utopie on Vimeo.



Utopie pro kazdy den

future | budoucnost

- IT Trojan Tactic
- Studio
- TRUE IS: WHERE
- TRASH IS:
- 25 Forgotten Buildings
- bar at Great Wall
- Factory for the Absolute
- Dirty paintings
- Hair Internat
- Individualised Food
- Weapons
- ISO Cafe
- Potatoe Season
- Oslavna rec, Speech
- Periscope out of scrap
- CCTV cameras
- Repair kiosk in
- Amsterdam
- Freedom free-doom
- solidarnosc clip
- IAU in ZK/U
- Kiosk v penzionu
- odlozeneho umeri
- Peripheral knowledge
- INI meeting
- LOS Legenda o sidlisti
- Opravy v Ceskem
- Krumlovi
- Nocni Cesky Krumlov
- KEP-2014
- Semestr SVU 2014
- Druzstevni publikace
- komiksu
- Navrh
- Ceskoslovenskeho
- pavilonu
- Silna kava v Berlino
- Zavarena mena
- Subconscious educative
- manual
- Tribute to instructions
- Waveform, Video to
- Volts
- Modely pro
- (Dis)harmon
- Kiosk pro A la
- recherche de la boheme
- perdue
- Gallery Ducato

past | minulost

- Pruhledna tajemstvi |
- Transparent Secret
- publikace KIOSK



Udoli kralu, Galerie AVU / 2011

Dalsi faze Exhumace.
4 HDD disky byly premeneny v popelniky a opatreny CNC popiskou. Jsou pripraveny k naplneni novym druhem informace.

Objekt vyrobeny z 32 ploten disku se souhrnou velikosti 1966,9366 GB.

prezentovano na vystave **Temna schranka** - Jakub Geltner, Martin Brazina, Jan Mastera, Michal Pustejovsky

///



Valley of the Kings, Gallery AVU / 2011

Next phase of Exhumation.
4 HDD transformed into ash trays with CNC engraving and ready to upload with information.

Object made out of 32 HDD plates with size 1966,9366 GB.

on exhibition **Dark Case** - Jakub Geltner, Martin Brazina, Jan Mastera, Michal Pustejovsky



Temná schránka – Dark Case / Gallery AVU, Prague, 2011
(curator *Katarina Chludiková*)



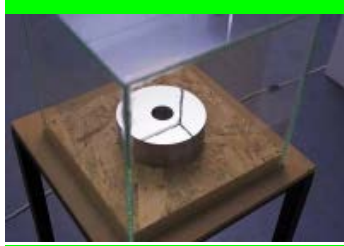



Text



Utopie pro kazdy den

future | budoucnost

- IT Trojan Tactic
- Studio
- TRUE IS WHERE
- TRASH IS
- 25 Forgotten Buildings
- bar at Great Wall
- Factory for the Absolute
- Dirty paintings
- Hair Internat
- Individualised Food
- Weapons
- ISO Cafe
- Potatoe Season
- Oslavna rec. Speech
- Periscope out of scrap
- CCTV cameras
- Repair kiosk in
- Amsterdam
- Freedom free-doom
- solidarnosc clip
- IAU in ZK/U
- Kiosk v penzionu
- odlozeneho umeri
- Peripheral knowledge
- INI meetings
- LOS Legenda o sidlisti
- opravy v Ceskem
- Krumlovi
- Nocni Cesky Krumlov
- REP-2014
- Semestr SVU 2014
- Druzstevni publikace
- komiks
- Navrh
- Ceskoslovenskeho
- pavilonu
- Silna kava v Berlina
- Zavarena mena
- Subconscious educative
- manual
- Tribute to instructions
- Waveform. Video to
- Voita
- Modely pro
- (Dis)harmon
- Kiosk pro A la
- recherche de la boheme
- perdue
- Gallery Ducate

past | minulost

Prhledna tajemstvi |



Text

Fragile Architecture | Krehka architektura

With need to protect small and fragile I aimed on small architectonic constructions.

- They are improvised.*
- They are ugly.*
- They are easily destructible.*
- They are colored.*
- They are human.*
- They are cheap.*
- They are punk.*
- They are left.*
- They are anti conventional.*
- They are unwanted.*
- They are tolerated.*

Fragile architecture are constructions which exists in direct opposition to inaccessible fortresses made from steel, glass and concrete. Fragile Architectures are mostly situated in interesting areas with essence of liberty. They serve daily routine of fastfood places, newsagent, foodstuff, greengrocery or bluecollar pub. Mostly builded by self-help of owners or conctructed prefabricated fragilie architecture stay and resist againts changes of regimes, time and developers intentions. Mapping and preserving situation of such a fragile constructions is done with medium of cut-out and give everyone chance to conctruct his own private fragile model.

[DOWNLOAD >>> 1st cut-out.pdf](#)

///

S pocitem potreby ochranovat male a slabe jsem se zameril na drobne architektonicke stavby.

- Jsou improvizovane.*
- Jsou osklive.*
- Jsou lehce znicitelne.*
- Jsou barevne.*
- Jsou lidske.*
- Jsou levne.*
- Jsou provokativni.*
- Jsou levicove.*
- Jsou nekonvencni.*
- Jsou nechtene.*
- Jsou tolerovane.*

Krehke budovy jsou stavby, které existují v přímém protikladu k nelidsky dokonalým a honosným palácům ze skla, oceli a kovu. Krehké budovy leží většinou v zajímavých částech města s nádechem rozvratu ale i svobody. Slouží denní potřebě jako rychlá občerstvení, novinové stánky, prodejny zeleniny a ovoce nebo jako nálevny a putyky. Většinou postaveny s pomocí, nebo z prefabrikovaných dílů, krehké stavby odolávají proudě času, změnám režimu a záměrům stavitelů a urbanistů. Dokumentace a průzkum krehkých staveb je realizován pomocí papírové vystřihovanky a dává každému šanci si postavit vlastní krehký model.

[DOWNLOAD >>> 1st cut-out.pdf](#)



Utopie pro kazdy den

future | budoucnost

- IT Trojan Tactics
- Studio
- TRUE IS: WHERE
- TRASH IS:
- 25 Forgotten Buildings
- bar at Great Wall
- Factory for the Absoluta
- Dirty paintings
- Hair Internat
- Individualised Food
- Weapons
- ISO Cafe
- Potatoe Season
- Oslovna rec... Speech
- Periscope out of scrap
- CCTV cameras
- Repair kiosk in Amsterdam
- Freedom free-doom
- solidarnosc clip
- IAU in ZK/Ú
- Kiosk v penzionu
- odlozeneho umeri
- Peripheral knowledge
- INI meeting
- LOS Legenda o sidlisti
- opravy v Ceskem
- Krumlovi
- Nočni Cesky Krumlov
- REP-2014
- Semestr SVU 2014
- Kruzstevni publikace
- komiksi
- Navrh
- Ceskoslovenskeho pavilonu
- Silna kava v Berlino
- Zavarena mena
- Subconscious educative manual
- Tribute to instructions
- Waveform: Video to Voits
- Modely pro
- (Dis)harmon
- Kiosk pro A la
- recherche de la boheme perdue
- Gallery Ducate

past | minulost

- Pruhledna tajemstvi
- Transparent Secret
- publikace KIOSK



Na cem sedi cely Island?

Na cem sedi Island? Na socpe? Na termalnich pramenech? Na vikingskem dedictvi? Na revolucni novovlade? Strcil jsem prsty do jeho soukromi.

Bylo tam toto



- malý zelený hřebec
- panacek Playmobil 1990
- linoryt kachny
- 20 penny mince
- 3x100 ISK mince
- 5x1 ISK mince
- male kazoo z lizatka
- dreveny knoflik olepeny s 4 dir.
- kolečko z Lega
- stipatko na nehty Prim
- baterie AAA (1,37 voltu) LRO3AM4
- knoflik pruhledny s jednou dirkou
- zvykacka v obalu
- musketa z Lega
- klic JMA bab 3d
- sponka do vlasu
- cigaretovy papirek Ga-jol
- plastova sponka od chleba
- pretrzeny retizek na privesek



What is Iceland sitting on?

What is Iceland sitting on? On a volcano? On thermal springs? On viking heritage? On revolutionary government? I put my fingers into its privacy.

There was this



- small green comb
- 1990 Playmobil puppet
- linocut of a duck
- 20 pence coin
- 3x100 ISK coin
- 5x1 ISK coin
- small kazoo from lollipop
- wooden button with 4 holes
- Lego wheel
- nail tongs with nail file Prim
- battery AAA (1,37 volt) LRO3AM4
- transparent button with one hole
- chewing gum in wrapper
- Lego musket
- key JMA bab 3d
- hair grip
- cigarette paper Ga-jol
- plastic bread fastener
- broken key chain

Na cem sedi cely Island?
 Na socpe? Na termalnich pramenech? Na vikingskem dedictvi? Na revolucni novovlade? Strcil jsem prsty do jeho soukromi.

What is Iceland sitting on?
 What is Iceland sitting on? On a volcano? On thermal springs? On viking heritage? On revolutionary government? I put my fingers into its privacy.

There was this

malý zelený hřebec
 panacek Playmobil 1990
 linoryt kachny
 20 penny mince
 3x100 ISK mince
 5x1 ISK mince
 male kazoo z lizatka
 dřevěný knoflík olepený s 4 dir.
 kolečko z Lega
 stipatko na nehty Prim
 baterie AAA (1,37 voltu) LRO3AM4
 knoflík průhledný s jednou dírkou
 žvýčková v obalu
 musketa z Lega
 klic JMA bab 3d
 sponka do vlasu
 cigaretový papírek Ga-jol
 plastová sponka od chleba
 přetržený řetízek na přívěsek

Text

Á hverju situr Ísland?

Á hverju situr Ísland? Á eldfjalli? Á hverum? Á víkingaarfleið? Á byltingarkenndri ríkisstjórn? Ég sting fingri mínum inn í einkalíf þess.

Þar var þetta

- litil græn greiða
- Playmobil kall frá 1990
- dúkrista af öndinni
- 20 aurar
- 3x100 ísl. krónur
- 5x1 ísl.króna
- kazú flauta úr sleikjó
- viðartala með 4 götum
- Legó hjól
- naglaklippa með naglaþjöl frá Prim
- AAA batteri (1,37 volt) LRO3AM4
- plasttala með 1 gagnsæju gati
- tyggjó í pakkningunum
- Legó byssa
- bab lykili JMA 3d
- hársþenna
- Ga-jol sigarettupappír
- plastfesting á brauð
- brostin lyklaklippa

Na cem sedi Island. / What is Iceland sitting on.

*/fotochemicky tisk s RGB osvitom, photo-chemical print with RGB exposure/
3 fotografie 13x19cm*

Dobre zpravy, spatne zpravy

Zucastnene pozorovani obycejne a medialni reality na podklade poklidneho pikniku na ledovci a sopce. Prace poukazuje na propastny rozdil mezi medialnim obrazem krajin nam vzdalenyh v porovnaní s skutecnosti v lidskem meritku. Intimita je vzdy pravdivejsi.

Pribeh 1 Celodeni vylet na sopku Katla z casti pokrytou ledovcem. Prochazka. Cesta na ledovec a nataceni cerne vlajky. Sber kamenu. Diskuze o umeni. Piknik. Caj, susenky, salam. **DOBRA ZPRAVA**

Pribeh 2 Islandska sopka Katla se probouzi. Hrozi rojem zemetreseni Zatimco obcasne otresy kolem Katly jsou caste, jejich prerustani do zemetresnych roju nikoli. Oznamili to vulkanologove z Islandske univerzity, kteri se snazi pred hrozicim vybuchem vcas varovat. "Katla je jednou z nejobavanejsich sopek na Islandu, proto ji podrobne sledujeme," rekl podle agentury AP Pall Einarsson z vulkanologickeho ustavu univerzity. "Je normalni, ze kolem Katly zaznamenavame zemetreseni. Neobvykle ale je, ze se otresy sdruzuji do roju opakujicich se ve zhruba desetiminutovych intervalech," dodal. **SPATNA ZPRAVA**

*Dobre zpravy, spatne zpravy. / Good news, bad news.
/fotochemicky tisk s RGB osvitom / photo-chemical print with RGB exposure/
1 fotografie 13x19cm*

Good news, bad news

(photo-chemical print with RGB exposure)

An involved observation of ordinary and media reality, based on a quiet picnic on a glacier and volcano. The work shows the enormous chasm between the media image of distant landscapes and human-scale reality. Intimacy is always more truthful.

Story 1 A day-trip to Katla volcano, which is partially covered by a glacier. A hike. Travelling along the glacier and filming black flags. Collecting stones. Discussing art. Picnic. Tea, cookies, salami. **GOOD NEWS**

Story 2 Iceland's Katla awakens, threatens earthquake cluster Although occasional tremors near Katla are no rarity, earthquakes clusters are uncommon here, say vulcanologists from the University of Iceland, who are trying to warn in time of the threat of an eruption. "Katla is one of Iceland's most feared volcanoes, which is why we are observing it carefully", AP quoted Pall Einarsson from the university's vulcanological institute as saying. "It is normal for us to record earthquakes near Katla. But it is unusual for these tremors to be grouped into clusters at roughly ten-minute intervals", he added. **BAD NEWS**

*Dobre zpravy, spatne zpravy. / Good news, bad news.
/fotochemicky tisk s RGB osvitom / photo-chemical print with RGB exposure/
1 photograph 13x19cm*



Utopie pro kazdy den

future | budoucnost

- IT Trojan Tactic
- Studio
- TRUE IS WHERE
- TRASH IS
- 25 Forgotten Buildings
- bar at Great Wall
- Factory for the Absolute
- Dirty paintings
- Hair Internal
- Individualised Food
- Weapons
- ISO Cafe
- Potatoe Season
- Oslovna rec. Speech
- Periscope out of scrap
- CCTV cameras
- Repair kiosk in Amsterdam
- Freedom free-doom
- solidarnosc clip
- IAU in ZK/U
- Kiosk v penzionu
- odlozeneho umeri
- Peripheral knowledge
- INI meetings
- LOS Legenda o sidlisti
- Opravy v Ceskem
- Krumlovi
- Nocni Cesky Krumlov
- REP. 2014
- Semestr SVU 2014
- Druzstevni publikace
- komiksu
- Navrh
- Ceskoslovenskeho pavilonu
- Silna kava v Berlina
- Zavarena mena
- Subconscious educative manual
- Tribute to instructions
- Waveform. Video to
- Volta
- Modely pro
- (Dis)harmon
- Kiosk pro A la
- recherche de la boheme
- perdue
- Gallery Ducato

past | minulost

- Pruhledna tajemstvi
- Transparent Secret
- publikace KIOSK

Cogitative Photography of Ordinary | Myslena fotografie beznost

Photographs which were created with absence of apparatus (as Vilém Flusser refers to complicated instrument designed for creating technical images) The sets of photography present first analogue part of work. The medium of image broadcasted to viewer is just idea (thought). With soul crowded with technical image and with frustration from digital and analogue clicks signaling that another one image have been produced, I decided to invent my own form of photography. This kind of photography is intimate, its modest, its cheap. Which my own apparatus you would never destroy even the most fragile moments. Further more to "develope" such a kind of images you dont need anything else, just your inner word and vocabulary. It would never happen to you, that you would seen something you dont know or you can't imagine. In such a case, you would see nothing. Just a few words. Just a code.

///

Serie fotografii byla vytvorena jen myslenkovym pochodem bez pritomnosti vyrobnihho prostredku „aparatu“ (apparatus), jak ho popisuje se vsemi aspekty Vilem Flusser nebo Walter Benjamin. Moje touha vymanit se z kolobehu vytvareni technicky obrazu a snaha nebyt jen delnikem obsluhujicim vyrobnihho prostredek me vedly k vytvoreni specialniho postupu fotografovani. Veskere aspekty jako pomer stran fotografie nebo pouzity material jsou verne zachovane. Jen v celem retezci chybi jiz zmineniy aparat na obrazy. Cely proces mi pomohl vytvaret daleko meditativnejsi a intimnejsi obrazy, nez bych byl kdy schopn se sebe mensim nebo vyspelejsim aparatem. Percepce mnou vytvorených obrazu je vetsinou na rovine myslenkove, imaginativni a intelektualni. Divak rozkryva drobne formy typu haiku. Vyvolava obrazy procesem ve sve hlavě. Mediem prenosu obrazu je myslenka.

Pridavna spojeni – Additional links / Gallery NTK, Prague, 2011
(curator *Tereza Severová* and *Christl Mudrak*) with Tomas Svoboda

Pridavna spojeni - Additional links / Galerie NTK, Praha, 2011
(kurator *Tereza Severova* a *Christl Mudrak*) s Tomasem Svobodou

Pridavna spojeni II. / Kunsthalle am Hamburger Platz, Berlin 2013
(kurator *Tereza Severova* a *Christl Mudrak*) s Tomasem Svobodou

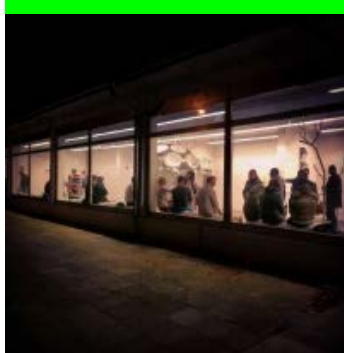



Utopie pro každý den

future | budoucnost

IT, Trojan Tactic,

Studio

TRUE IS: WHERE

TRASH IS:

25 Forgotten Buildings

bar at Great Wall

Factory for the Absolute

Dirty paintings

Hair, Internet

Individualised Food

Weapons

ISO Cafe

Potatoes Season

Oslavná rec., Speech

Periscope out of scrap

CCTV cameras

Repair kiosk in

Amsterdam

freedom tree-doom

solidarosc clip

IAU in ZK/Ú

Kiosk v penzionu

odlozeného umění

Peripheral knowledges

INI meetings

LOS Legendy o sídlisti

Opravy v Ceskem

Krumlov

Noční Český Krumlov

EEP_2014

Semestr SVU 2014

Družstevní publikace

komiksu

Navrh

Československého

pavilonu

Silná káva v Berlíně

Zavazena mana

Subconscious educative

manual

Tribute to Instructions

Waveform, Video to

Volte

Modely pro

(Dis)harmonii

Kiosk pro A ja

recherche de la bohème

perdue

Gallery Ducati

past | minulost

Průhledná tajemství



Salt buried in Plastic

(video loop and objects, 4.59min)

The story of creating artefact. From unwanted material can be born usable item. Presented video is tutorial for unlimited possibility of improvisation, no-budget attitude and prolonging of lifespan of material.

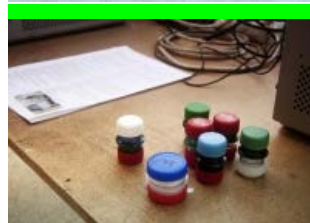

Sul pohrbena v plastu

(objekty a video smyčka 4.59min)

Příběh o zrození předmětu. Z nechtěného kusu materiálu vzniká užitečný artefakt. Představené video je navodem a motivací k nekonečným možnostem improvizace, bez rozpočtové realizace a prodloužení životnosti již existujícího materiálu nebo suroviny.

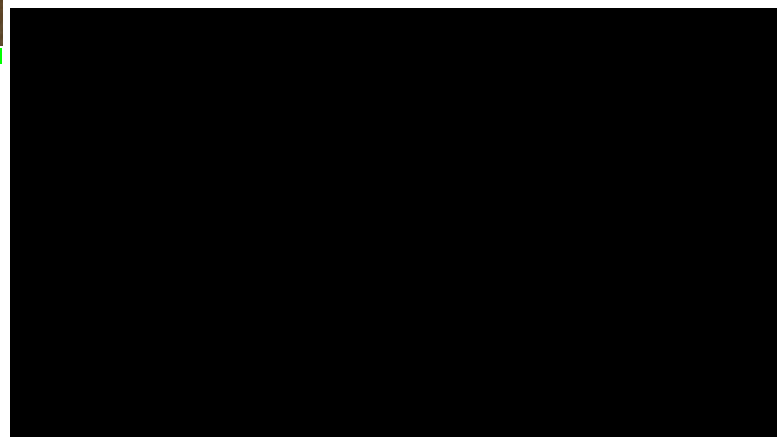

Salt buried in Plastic / Sul pohrbena v plastu from Viktor z Utopie on Vimeo.



Utopie pro kazdy den

future | budoucnost

- IT Trojan Tactic
- Studio
- TRUE IS: WHERE
- TRASH IS:
- 25 Forgotten Buildings
- bar at Great Wall
- Factory for the Absolute
- Dirty paintings
- Hair Internat
- Individualised Food
- Weapons
- ISO Cafe
- Potatoe Season
- Oslavna rec., Speech
- Periscope out of scrap
- CCTV cameras
- Repair kiosk in
- Amsterdam
- Freedom free-doom
- solidarnosc clip
- IAU in ZK/U
- Kiosk v penzionu
- odlozeneho umeri
- Peripheral knowledge
- INI meetings
- LOS Legenda o sidlisti
- Opravy v Ceskem
- Krumlovi
- Nocni Cesky Krumlov
- KEP_2014
- Semestr SVU 2014
- Druzstevni publikace
- komiksu
- Navrh
- Ceskoslovenskeho
- pavilonu
- Silna kava v Berlina
- Zavarena mena
- Subconscious educative
- manua
- Tribute to instructions
- Waveform, Video to
- Volts
- Modely pro
- (Dis)harmon
- Kiosk pro A la
- recherche de la boheme
- perdue
- Gallery Ducato

past | minulost

Pruhledna tajemstvi



Text

PPP

PPF

poetická politická pohádka
poetic political fairytale

Pribeh hrabive princezny K.

Princezna K. velmi zbohatla.
Pak princezna K. zase prudce zchudla.
A z toho zchudnuti zacala nepricetne radit.

Tale of the Greedy Princess K.

Princess K. became very rich.
Than princess K. rapidly bacame poor.
And then she bagan to rage insanely.

[PPP_DOWNLOAD.PDF](#)



Utopie pro kazdy den

future | budoucnost

- [IT Trojan Tactic](#)
- [Studio](#)
- [TRUE IS: WHERE](#)
- [TRASH IS:](#)
- [25 Forgotten Buildings](#)
- [bar at Great Wall](#)
- [Factory for the Absolute](#)
- [Dirty paintings](#)
- [Hair: Internet](#)
- [Individualised Food](#)
- [Weapons](#)
- [ISO Cafe](#)
- [Potatoes Season](#)
- [Oslavna rec_Speech](#)
- [Periscope out of scrap](#)
- [CCTV cameras](#)
- [Repair kiosk in](#)
- [Amsterdam](#)
- [freedom tree-doom](#)
- [solidarnosc clip](#)
- [Kiosk in ZK/Ú](#)
- [Kiosk v penzionu](#)
- [odlozeneho umeni](#)
- [Peripheral knowledges](#)
- [INI meetings](#)
- [LOS Legendy o sidisti](#)
- [Opravy v Ceskem](#)
- [Krumlovi](#)
- [Nochi Cesky Krumlov](#)
- [EEP_2014](#)
- [Semestr SVU 2014](#)
- [Druzstevni publikace](#)
- [komiksu](#)
- [Navrh](#)
- [Ceskoslovenskeho](#)
- [pavilonu](#)
- [Silná káva v Berlíně](#)
- [Zavazna mana](#)
- [Subconscious educative](#)
- [manual](#)
- [Tribute to Instructions](#)
- [Waveform: Video to](#)
- [Volta](#)
- [Modely pro](#)
- [\(Dis\)harmon](#)
- [Kiosk pro A ja](#)
- [recherche de la boheme](#)
- [perdue](#)
- [Gallery Ducati](#)

past | minulost

- [Pruhledna tajemství](#)

Neviditelne stare medium | Invisible old medium / 2012

Nekolik malych banalnich pribehu odehravajících se na pozadí stareho media. Obsahem prace je zviditelneni media prenosu nejvetsi možnou merou. Prace se snazi pouzít pristup imediace i hypermediace v jedne casove urovni. Soucasti hypermediace je i obsahova stridmost probíhajících deje, který je zamerne malo medialne obsazny. Spise nez o deji lze to co se ve video stope odehrava oznacit jako staromedialni zatisi.



Text

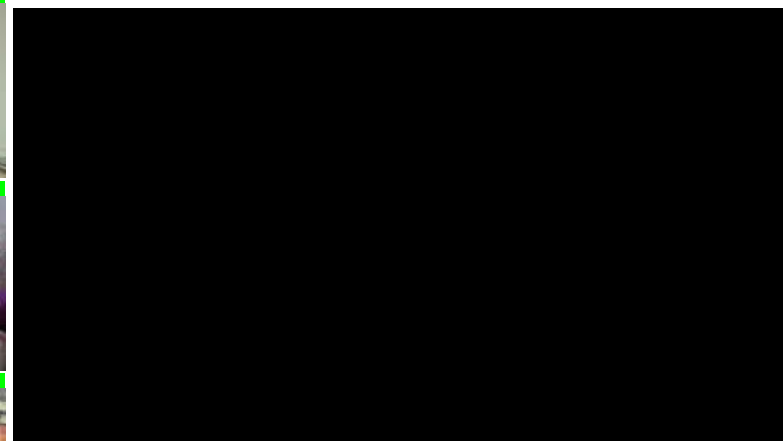



Utopie pro kazdy den

future | budoucnost

IT Trojan Tactic

Studio

TRUE IS: WHERE

TRASH IS:

25 Forgotten Buildings

bar at Great Wall

Factory for the Absolute

Dirty paintings

Hair: Interiors

Individualised Food

Weapons

ISO Cafe

Potatoes: Season

Oslavna rec: Speech

Periscope out of scrap

CCTV cameras

Repair kiosk in

Amsterdam

freedom tree-doom

solidarnosc clip

IAU in ZK/Ú

Kiosk v penzionu

odlozeného umění

Peripheral knowledges

INI meetings

LOS: Legenda o sidlisti

Opravy v Ceskem

Krumlovi

Noční Český Krumlov

EEP 2014

Semestr SVU 2014

Družstevní publikace

kamiku

Navrh

Československého

pavilonu

Silná káva v Berlíně

Zavazna mana

Subconscious educative

manual

Tribute to Instructions

Waveform: Video to

Volta

Modely pro

(Dis)harmoni

Kiosk pro A ja

recherche de la bohème

perdue

Gallery Ducato

past | minulost

Průhledná tajemství

Transparent Secret

publikace KIOSK

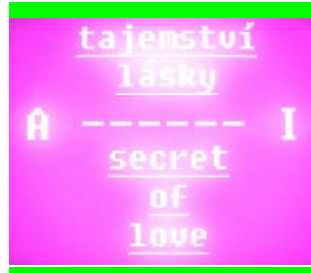

Text

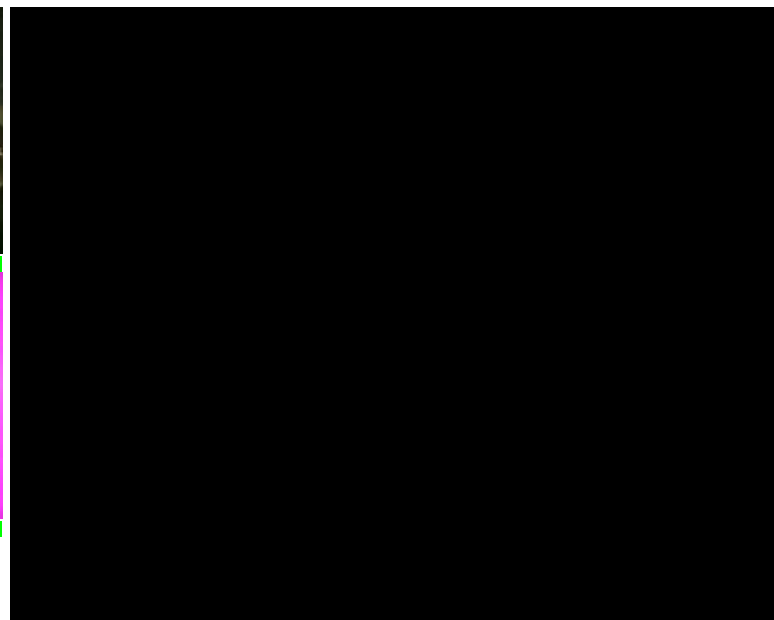

Tajemství lásky ?? Secret of Love from Viktor z Utopie on Vimeo.

Účinkují -- Appears

- Abba Eban
- Abdel Rahman Sadek
- Abu Ali Shaheen
- Abu Jihad
- Abu Mazen
- Adel Sabit
- Alexander Hais
- Anatoly Dobrynin
- Ariel Sharon
- Ben Zion Cohen
- Benjamin Givli
- Boutros Boutros-Ghali
- Clark Clifford
- Dean Brown
- Dr. George Habash
- Elliot Richardson
- Evgeny Pyrlin
- Ezer Weizman
- Ezra Yakhin
- Faisal Husseini
- Farouk Al-Shar?a
- Fuad Ben Eliezer
- General Ehud Barak
- General Fawzi
- General Gamasy
- General Gavish
- General Haditha
- General Hod
- General Kirpichenko
- General Meir Amit
- General Mitzna
- General Narkiss
- General Noufal
- General Reshetnikov
- General Tal
- General Tlas
- General Weizman
- General Zeira
- George Bush
- George Shultz
- Gideon Rafael
- Golda Meir
- Hanan Ashrawi
- Hazem Nusseibeh
- Henry Kissinger
- Hermann Eilts
- James Baker
- Jimmy Caqrter
- Jonny Abdu
- Joseph Sisco
- Karim Pakradouni
- King Hussein
- Marcelle Ninio
- Marchal Shazli
- Meir Pail
- Miriam Eshkol
- Mohammed Labadi
- Mohsein Abdek Khalek
- Moshe Arens

Moshe Dayan
Mustafa Khalil
Mustafa Tlas
Pogol Akopov
President Numeiry
President Richard Nixon
Prince Bin Shakir
Ran Peker
Richard Haass
Robert Dassa
Robert McNamara
Saeb Erakat
Salah Bassuouny
Shafiq Hout
Shams Badran
Shimon Peres
Taher Masri
Umm Jihad
Uzi Narkiss
Walt Rostow
Yair Zaban
Yasser Abed Rabbo
Yitzhak Navon
Yitzhak Rabin
Yitzhak Shamir
Yossi Ben Aharon
Zachariah Muhieddin
Zbigniew Brzezinski
Ziamah Divon



Utopie pro kazdy den

future | budoucnost

- IT Trojan Tactic Studio
- TRUE IS: WHERE TRASH IS.
- 25 Forgotten Buildings
- bar at Great Wall
- Factory for the Absolute
- Dirty paintings
- Hair Internat
- Individualised Food
- Weapons
- ISO Cafe
- Potatoe Season
- Oslavna rec. Speech
- Periscope out of scrap
- CCTV cameras
- Repair kiosk in Amsterdam
- Freedom free-doom
- solidarnosc clip
- IAU in ZK/U
- Kiosk v penzionu
- odlozeneho umeri
- Peripheral knowledges
- INI meetings
- LOS Legenda o sidlisti
- Opravy v Ceskem
- Krumlovi
- Nocni Cesky Krumlov
- KEP_2014
- Semestr SVU 2014
- Druzstevni publikace
- komiksu
- Navrh
- Ceskoslovenskeho pavilonu
- Silna kava v Berlina
- Zavarena mena
- Subconscious educative manual
- Tribute to instructions
- Waveform. Video to
- Volts
- Modely pro
- (Dis)harmon
- Kiosk pro A la
- recherche de la boheme
- perdue
- Gallery Ducate

past | minulost

Prhledna tajemstvi |

Model kiosku 1:20.



Text



Utopie pro kazdy den

future | budoucnost

- IT Trojan Tactic
- Studio
- TRUE IS: WHERE
- TRASH IS:
- 25 Forgotten Buildings
- bar at Great Wall
- Factory for the Absolute
- Dirty paintings
- Hair Interna
- Individualised Food
- Weapons
- ISO Cafe
- Potatoe Season
- Oslavna rec, Speech
- Periscope out of scrap
- CCTV cameras
- Repair kiosk in Amsterdam
- Freedom free-doom
- solidarnosc clip
- IAU in ZK/U
- Kiosk v penzionu
- odlozeneho umeri
- Peripheral knowledge
- INI meeting
- LOS Legenda o sidlisti
- Opravy v Ceskem
- Krumlov
- Nocni Cesky Krumlov
- EEP 2014
- Semestr SVU 2014
- Druzstevni publikace
- komiksu
- Navrh
- Ceskoslovenskeho pavilonu
- Silna kava v Berlino
- Zavarena mena
- Subconscious educative manual
- Tribute to instructions
- Waveform, Video to
- Volts
- Modely pro
- (Dis)harmon
- Kiosk pro A la
- recherche de la boheme
- perdue
- Gallery Ducato

past | minulost

- Prhledna tajemstvi
- Transparent Secret
- publikace KIOSK



Malomestská hlina

Rozhodl jsem se kolem Prahy vysázet zelený kruh z celoročně zelené rostliny. Sazenice jsem přivezl do Prahy z malého města. Břectan popínavy jsem sázel tak, aby přežil a mohl se rozšířit. Břectan (**Hedera Helix**) je dominantní, ale ne invazivní rostlina. V budoucnosti bude vše porostlé břectanem.



Text



Utopie pro kazdy den

future | budoucnost

- IT Trojan Tactic
- Studio
- TRUE IS: WHERE
- TRASH IS:
- 25 Forgotten Buildings
- bar at Great Wall
- Factory for the Absolute
- Dirty paintings
- Hair Internat
- Individualised Food
- Weapons
- ISO Cafe
- Potatoe Season
- Oslavna rec...Speech
- Periscope out of scrap
- CCTV cameras
- Repair kiosk in
- Amsterdam
- Freedom free-doom
- solidarnosc clip
- IAU in ZK/U
- Kiosk v penzionu
- odlozeneho umeri
- Peripheral knowledge
- INI meetings
- LOS Legenda o sidlisti
- Opravy v Ceskem
- Krumlovi
- Nocni Cesky Krumlov
- REP_2014
- Semestr SVU 2014
- Druzstevni publikace
- komiksu
- Navrh
- Ceskoslovenskeho
- pavilonu
- Silna kava v Berlina
- Zavarena mena
- Subconscious educative
- manua
- Tribute to instructions
- Waveform_Video to
- Voits
- Modely pro
- (Dis)harmon
- Kiosk pro A la
- recherche de la boheme
- perdue
- Gallery Ducate

past | minulost

Prhledna tajemstvi



Text

58 stran

manifest krehké architektury

Jsou improvizované.
 Jsou ošklivé.
 Jsou lehce znicitelné.
 Jsou barevné.
 Jsou lidské.
 Jsou levné.
 Jsou provokativní.
 Jsou levicové.
 Jsou nekonvenční.
 Jsou nechtené.
 Jsou tolerované.
 Krehké budovy jsou stavby, které existují v primém protikladu k nelidsky dokonalým a honosným palácům ze skla, oceli a kovu.
 Krehké budovy leží většinou v zajímavých částech mesta s nádechem rozvratu, ale i svobody.
 Slouží denní potrebe jako rychlá obcerstvení, novinové stánky, prodejny zeleniny a ovoce nebo jako nálevny a putyky.

manifest mastných stánku

Jsou improvizované.
 Jsou ošklivé.
 Jsou lehce znicitelné.
 Jsou barevné.
 Jsou lidské.
 Jsou levné.
 Jsou provokativní.
 Jsou levicové.
 Jsou nekonvenční.
 Jsou nechtené.
 Jsou tolerované.
 Mastné budovy jsou stavby, které existují v primém protikladu k nelidsky dokonalým a honosným palácům ze skla, oceli a kovu.
 Mastné budovy leží většinou v zajímavých částech mesta s nádechem rozvratu, ale i svobody.
 Slouží denní potrebe jako rychlá obcerstvení, novinové stánky, prodejny zeleniny a ovoce nebo jako nálevny a putyky.



Utopie pro kazdy den

future | budoucnost

- IT Trojan Tactic
- Studio
- TRUE IS: WHERE
- TRASH IS.
- 25 Forgotten Buildings
- bar at Great Wall
- Factory for the Absolute
- Dirty paintings
- Hair Internat
- Individualised Food
- Weapons
- ISO Cafe
- Potatoe Season
- Oslavna rec. Speech
- Periscope out of scrap
- CCTV cameras
- Repair kiosk in
- Amsterdam
- Freedom free-doom
- solidarnosc clip
- IAU in ZK/U
- Kiosk v penzionu
- odlozeneho umeri
- Peripheral knowledge
- INI meetings
- LOS Legenda o sidlisti
- Opravy v Ceskem
- Krumlovi
- Nocni Cesky Krumlov
- KEP_2014
- Semestr SVU 2014
- Druzstevni publikace
- komiksu
- Navrh
- Ceskoslovenskeho
- pavilonu
- Silna kava v Berlina
- Zavarena mena
- Subconscious educative
- manua
- Tribute to instructions
- Waveform. Video to
- Volts
- Modely pro
- (Dis)harmon
- Kiosk pro A la
- recherche de la boheme
- perdue
- Gallery Ducate

past | minulost

- Prhledna tajemstvi



Konecná utopie, vystupovat!

Ve hře **VirtualBus A4C/A4E** jsem dojel na místo mezi panelové domy. Zastavil, vypnul motor a spustil výstražná světla. Otevrel jsem dveře. Konečná, všichni ven!

pro **RPSP**

Rybník panelových sídlišť Prahy
15. -- 30. 10. 2012 -- GAVU

Text



Utopie pro každý den

future | budoucnost

- IT Trojan Tactic
- Studio
- TRUE IS: WHERE
- TRASH IS:
- 25 Forgotten Buildings
- bar at Great Wall
- Factory for the Absolute
- Dirty paintings
- Hair Interns
- Individualised Food
- Weapons
- ISO Cafe
- Potatoe Season
- Oslavna rec. Speech
- Periscope out of scrap
- CCTV cameras
- Repair kiosk in
- Amsterdam
- Freedom free-doom
- solidarosc clip
- IAU in ZK/U
- Kiosk v penzionu
- odlozeneho umeri
- Peripheral knowledge
- INI meetings
- LOS Legenda o sidlisti
- Opravy v Ceskem
- Krumlovi
- Nocni Cesky Krumlov
- KEP_2014
- Semestr SVU 2014
- Druzstevni publikace
- komiksu
- Navrh
- Ceskoslovenskeho
- pavilonu
- Silna kava v Berlina
- Zavarena mena
- Subconscious educative
- manua
- Tribute to instructions
- Waveform. Video to
- Volts
- Modely pro
- (Dis)harmon
- Kiosk pro A la
- recherche de la boheme
- perdue
- Gallery Ducate

past | minulost

Pruhledna tajemstvi |



Pruhledná tajemství AVU.
Laser tisk na pauzovací papír, light box.



Text



Text

electronic

viktorhelp2(at)gmail.com
+420 774 806 059 CZ
telegram.me/viktorhelp

analogue

Leave handwritten message and send me GPS coordinates.

gonzo

- artusdelavilleon.com
- blackmedia-society.blogspot.com
- difusehavr.cz
- janbroz.cz
- nmedia.avu.cz
- novakmartin.cz
- palpalpal.cz
- dirloz.net
- getner.cz
- kyklogalaktikos.cz
- martinbrazina.cz
- onepicture.org
- starovecky.com
- the-low-orbit.net
- anetta mona chisa & lucia tkacova
- ilga vokálova
- michal pustejovsky
- adela kremplova
- galerie ducate
- reykjavik-prague intermedia bridge
- stepan marko
- galerie v penězence
- the jauf
- ontogenie
- galerie ducate
- black media
- kbooks
- marketa mrackova
- sdruzeni kosa
- lenka burdova
- andrej vicena



Utopie pro kazdy den

future | budoucnost

- IT Trojan Tactic
- Studio
- TRUE IS: WHERE
- TRASH IS:
- 25 Forgotten Buildings
- bar at Great Wall
- Factory for the Absolute
- Dirty paintings
- Hair Internat
- Individualised Food
- Weapons
- ISO Cafe
- Potatoe Season
- Oslavna rec, Speech
- Periscope out of scrap
- CCTV cameras
- Repair kiosk in
- Amsterdam
- Freedom free-doom
- solidarnosc elip
- IAU in ZK/U
- Kiosk v penzionu
- odlozeneho umeri
- Peripheral knowledge
- INI meetings
- LOS Legenda o sidlisti
- Opravy v Ceskem
- Krumlovi
- Nocni Cesky Krumlov
- KEP_2014
- Semestr SVU 2014
- Druzstevni publikace
- komiksu
- Navrh
- Ceskoslovenskeho
- pavilonu
- Silna kava v Berlina
- Zavarena mena
- Subconscious educative
- manua
- Tribute to instructions
- Waveform, Video to
- Volts
- Modely pro
- (Dis)harmon
- Kiosk pro A la
- recherche de la boheme
- perdue
- Gallery Ducate

past | minulost

Pruhledna tajemstvi



[2014 PDF](#)

[12-13 PDF](#)

[2011-2012 PDF](#)

[2011 PDF](#)

[2010-2011 PDF](#)

[Stalo se, 2010-2011 PDF](#)

[2009-2010 PDF](#)

Utopie pro kazdy den

future | budoucnost

[IT Trojan Tactic](#)
[Studio](#)
[TRUE IS: WHERE](#)
[TRASH IS](#)
[25 Forgotten Buildings](#)
[bar at Great Wall](#)
[Factory for the Absolute](#)
[Dirty paintings](#)
[Hair Internat](#)
[Individualised Food](#)
[Weapons](#)
[ISO Cafe](#)
[Potatoe Season](#)
[Oslavna rec, Speech](#)
[Periscope out of scrap](#)
[CCTV cameras](#)
[Repair kiosk in](#)
[Amsterdam](#)
[Freedom free-doom](#)
[solidarnosc clip](#)
[IAU in ZK/U](#)
[Kiosk v penzionu](#)
[odlozeneho umeri](#)
[Peripheral knowledges](#)
[INI meetings](#)
[LOS Legenda o sidlisti](#)
[Opravy v Ceskem](#)
[Krumlovi](#)
[Nočni Cesky Krumlov](#)
[KEP_2014](#)
[Semestr SVU 2014](#)
[Druzstevni publikace](#)
[komiksu](#)
[Navrh](#)
[Ceskoslovenskeho](#)
[pavilonu](#)
[Silna kava v Berlina](#)
[Zavarena mena](#)
[Subconscious educative](#)
[manua](#)
[Tribute to instructions](#)
[Waveform, Video to](#)
[Volts](#)
[Modely pro](#)
[\(Dis\)harmon](#)
[Kiosk pro A la](#)
[recherche de la boheme](#)
[perdue](#)
[Gallery Ducato](#)

past | minulost

[Prhledna tajemstvi](#)



PERIFERNÍ



ZNALOSTI

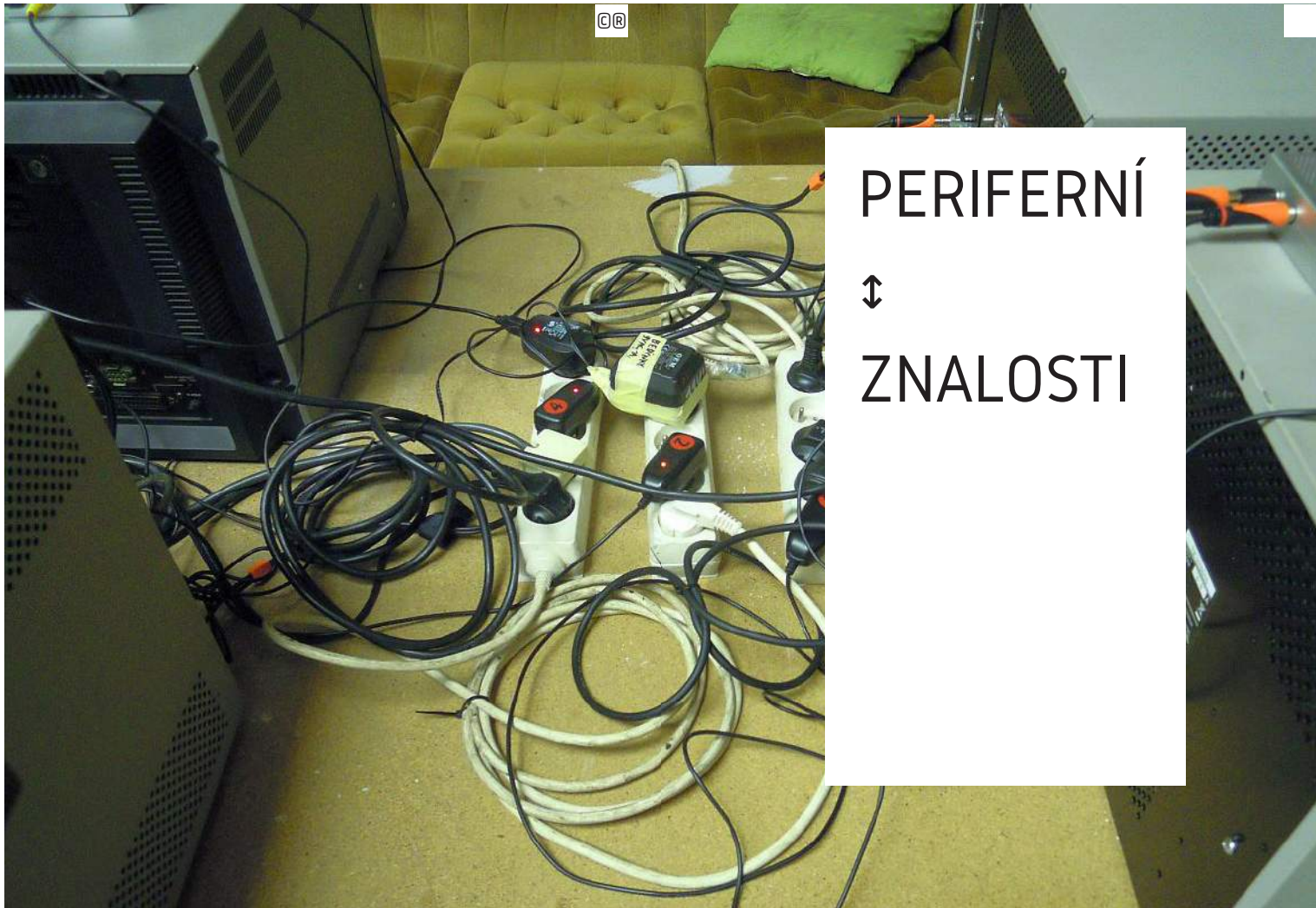

PERIFERNÍ ↔ ZNALOSTI

PERIFERNÍ ↔ ZNALOSTI

Viktor Vejvoda ↔ 2015

≈ utopia.comlu.com

Program podpořila AVU a INI.

Vytiskla QMS magicolor 2200 díky ovladači foo2zjs.ppd

výtisk → --- | --- série ---

1→
ZÁKLADNÍ
NÁSTROJE
A
PÁJENÍ



PERIFERNÍ ↔ ZNALOSTI

V rámci rezidence v INI galerii v bývalých Elektrických podnicích proběhne série setkání, která budou seznamovat s užitečnými znalostmi při opravách a tvorbě, s teoretickými příklady řešení, ale i s možností si některé opravy a postupy vyzkoušet vlastnoručně.

Téma oprav, využití a znovuvyužití morálně zastaralých předmětů, recyklace či duševní přístup k samotné opravě vnímám jako pole, které má emancipační potenciál pro umělce. Ovládnutím různorodých pracovních činností se umělec přesouvá z role zadavatele zakázek a zákazníka do pozice tvůrce.

Projekt zahrnuje i prostor pro konzultace. Výukové bloky budou rozšiřovat povědomí o činnostech, které můžeme sami provést a bude se věnovat přístupům k řešení problémů, se kterými jsem se setkal na poli nových médií.

Opravy, improvizace a vlastnictví opravných prostředků jsou pro současnost neekonomickým způsobem řešení problému. Z ekologického úhlu pohledu jsou ale tato řešení správná.

Jednotlivé činnosti mají i výtvarný aspekt. Například svářečka jako 160ampérová světelná orgie, reinkarnace elektrických článků v Elektrických podnicích nebo vůně a dým z páleného tavidla jako paralela starořeckého mystéria z Kolofónu.

Současné kutilství se dá vnímat jako přímá opozice převažující industrializace a modernizace našeho světa, která posouvá mnoho aspektů kulturní a konzumní estetiky mimo ruční výrobu, mimo řemeslnictví, do polohy masové produkce moderních vizí budoucnosti. Z tohoto pohledu může být kutilství radikální politická aktivita, aktivizmus, který se staví proti viditelným trendům masového vyrábění, pásové a sériové výroby, proti hromadnému konzumu, masivní produkci odpadu, proti korporátní filozofii plánované životnosti a morální opotřebovanosti.

PROGRAM PRVNÍHO SETKÁNÍ

ve středu 11. 3. 2015 od 19 hodin
Bubenská 1, Praha 7, dveře č. 114

Úvodní setkání. Opravy a emancipace umělce pomocí osvojení si nových dovedností. Stav rozbitého předmětu a duševní příprava na opravu. Jednoduché a nedostupnější nástroje pro základní opravy možná najdete doma. Základní princip měkkého pájení. Představení dostupných prostředků pro pájení, ukázka pracovního postupu. Praktická část pro zájemce. Odizolování vodiče, letování, první vodičový spoj a jeho izolace. Kde v Praze najdete nejlepší vodič zcela zdarma?

Oprav sám \equiv a sebe.

Opravovat začíněj ničením.

Nepoutej se na předmět
opravy.
Dělej, že ho nevidíš.

Nejlépe se opravuje to, co
už nikdo nechce.

Nástroje smíchej do jedno-
ho místa.

Nástroje jsou všude okolo.
 \equiv
Potřebný nástroj vždy chybí.

Dostupné nástroje pro jednoduché opravy



New Repair C
5S iPod

19.51 CZK

Buy It Now

Free internation

138 sold



cena s DPH / kus	9,00 Kč
cena bez DPH / kus:	7,44 Kč
množstevní slevy (bez DPH):	
≥ 50 kusů	5,97 Kč

dostupnost

Centrální sklad	skladem
Pízeň	10 kusů
Praha	3 kusy



cena

cena s DPH / kus	30,00 Kč
cena bez DPH / kus:	24,80 Kč

dostupnost

Centrální sklad	32 kusů
Pízeň	8 kusů
Praha	4 kusy
Brno	12 kusů
Hradec Králové	3 kusy
Ostrava	9 kusů

cena investice ▷ 59,-

Vybavení pro základní měkké pájení



Pájka LTQ 25/130W

159,00 Kč

Cinová pájka C1N 1mm 10g Sn60Pb40E SOLDER

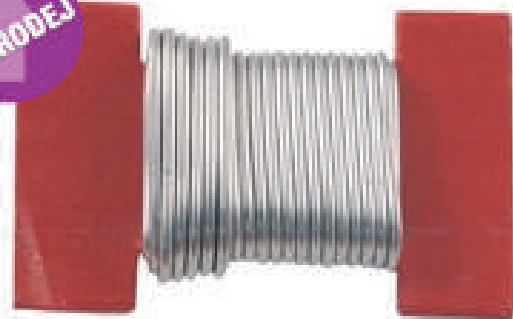

13,00 Kč



Kalafuna malá 16g v kelímku s dotací MTL408

26,00 Kč



**Nůž ulamovací 18mm
plastový**

15,00 Kč



**Izolační páska PVC
15/10m černá**

8,00 Kč

DOPORUČUJEME



Odsávačka cínu Turbo/II

50,00 Kč

cena investice ➤ 271,-

ELEKTRO A NÁŘADÍ

Tipa
Mezi Vodami 1955, Praha 4
areál ELEKTROPŘÍSTROJ
724 216 176, 800 100 433
tipa.eu

GES Electronics
Myslíkova 31, Praha 1
222 724 803
www.ges.cz

GM Electronic
Thámova 15, Praha 8
226 535 171
www.gme.cz

Bazar Technik
Korunovační 311/4, Praha 7
603 834 701
www.bazartechnik.cz

Vlastimil Štípský
Vinařská 9, Praha 7
731 824 485
stipsky.cz

BAZARY



→ VLASTIMIL ŠTÍPSKÝ

ŽELEZÁŘSTVÍ

Železářství
Bořivojova 45, Praha 3
773 647 385
profi-kutil.cz

Železářství U Rotta
Bubenské nábřeží 306, Praha 7
Holešovická tržnice - Hala 36
602 250 074
www.urotta-vo.cz

V.J. Rousek
Náměstí Bratří Synků 9, Praha 4
241 741 022
www.vjrousek.cz

SPOJOVACÍ A KOVOVÝ MATERIÁL

Ferona
U Pergamenky 11, Praha 7
274 074 510
www.ferona.cz



← ARCHITEKT JOSEF KŘÍŽ, FERONA, 1929

2↘
160
AMP

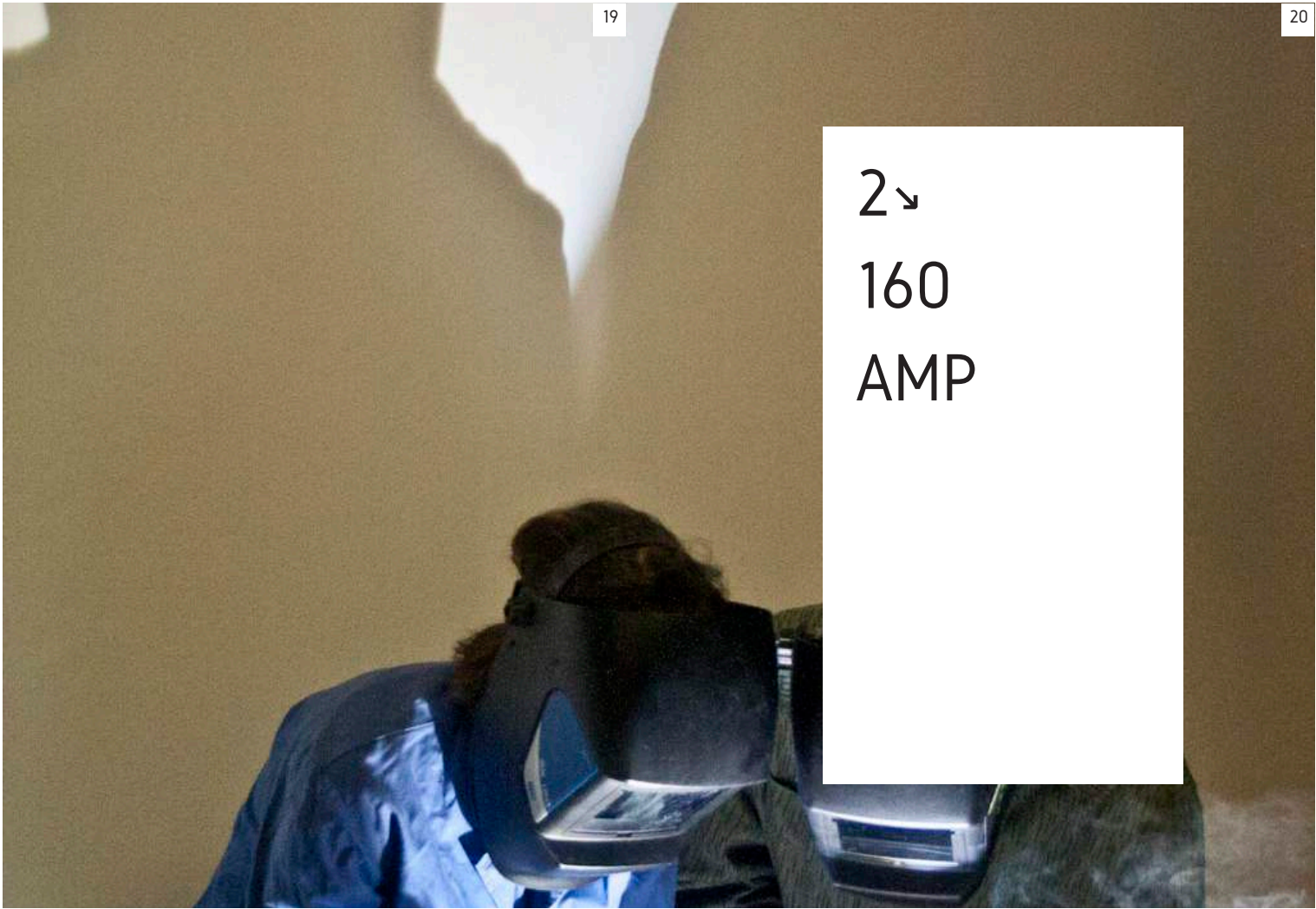

160 AMP

Možnosti sváření přímo v galerii. Člověk a kov o teplotě 4200–6400 °C. Tvorba vlastního nástroje. Zásady bezpečnosti. Poslední smrtelná rána dřevěnému soklu – svařený sokl. Svářečka jako nástroj pro lightshow a doprovod k poslechu zvukové stopy.

Pro zájemce budou připraveny informace o možnostech sváření různých druhů kovů, potřebné nástroje a vybavení. Nejdůležitější z návštěvníků budou mít možnost vytvořit svůj první svařený spoj. Tekoucí kov, modrofialová záře, silná káva a Sprite.

PROGRAM DRUHÉHO SETKÁNÍ

We are breathing 160 Amp real Air ve středu 25. 3. 2015 od 19 hodin Bubenská 1, Praha 7, dveře č. 114

Při dalším setkání v INI prostoru bude použita síla 160 ampérů svářečícího invertoru jako nástroj pro vznik elektrické světelné hry doprovázené hudební stopou a další novou instalací z již představeného stolu.





+ NÁSTROJ VYTVOŘENÝ SVÁREM MARKA Š.



+ PŘÍMÝ PŘENOS ZE SVÁŘECÍ KOMORY SLOUŽÍ JAKO OBRAZOVÝ DOPROVOD HUDEBNÍCH SKLADEB

NÁKUPNÍ SEZNAM

- invertorová svářečka (max. 160 amp.)
- svářecí kukla DIN 11
- rukavice Merlin
- úhlová bruska Hitachi
- bazické a rutilové elektrody
- ochranný plášť vzor Jehličí
- respirátor a uzavřené brýle
- brusná a řezný kotouč 115 mm



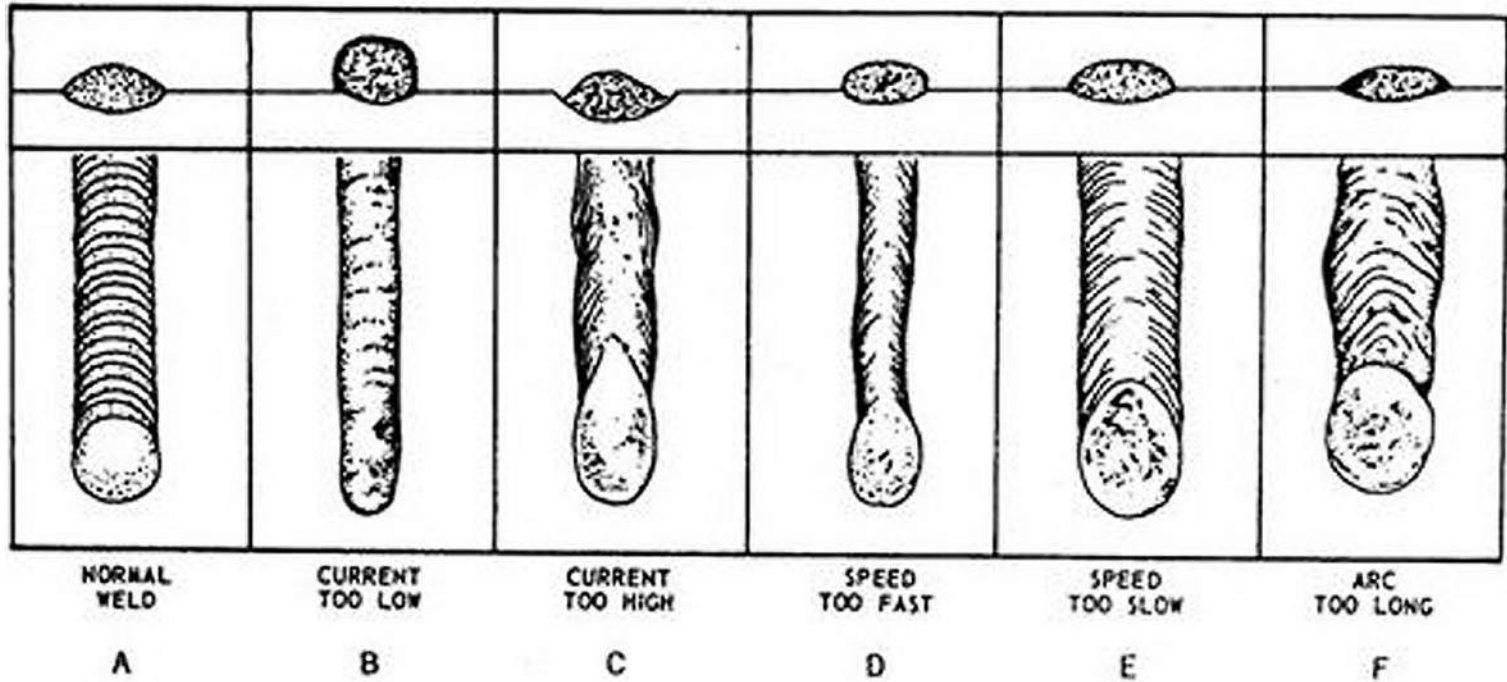

3
E. ČLÁNKY
V
E. POD-
NICÍCH



ELEKTRICKÉ ČLÁNKY V ELEKTRICKÝCH PODNICÍCH

Ukládání energie do baterie je denně nabývaná a znovu ztrácená osobní zásoba. Popis průmyslové baterie 18650 a její snadné získání. Posouzení kvality, kapacity článku a jeho bezpečnostních rizik. Představení jednoduché nabíječky a měniče pro baterii Li-Ion. Nabíječka nahlížená jako složitá instituce, která oddaně chrání energetický článek. Možnosti, jak lze provozovat drobná zařízení bez přístupu k elektrické síti. Východiska pro novomediální v divočině. Zajímavá schémata integrovaných obvodů a jejich funkce při nabíjení.

PROGRAM TŘETÍHO SETKÁNÍ

ve středu 8. 4. 2015 od 19 hodin
Bubenská 1, Praha 7, dveře č. 114

Po teoretické části budou připraveny nástroje a ochranné pomůcky pro získání Li-Ion článků z již slabé nebo odložené baterie do laptopu a příležitost k sestavení vlastního USB zdroje energie a nabíječky Li-Ion. Záměr vyzývá k přinesení vlastní nepotřebné baterie z přenosného počítače.

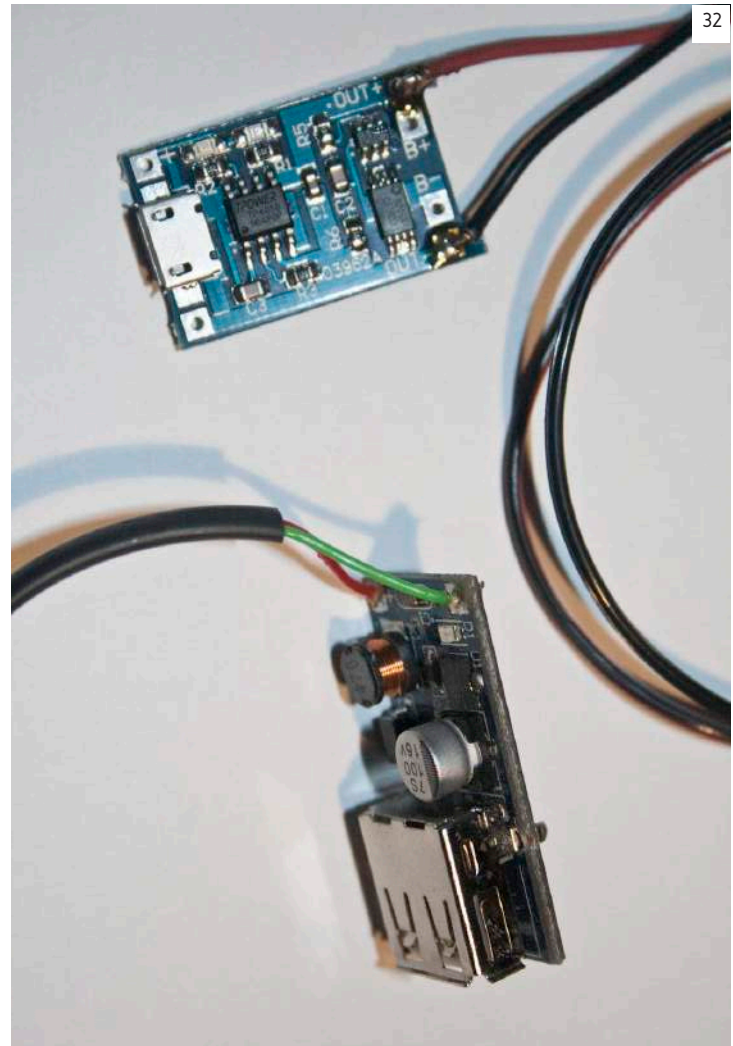

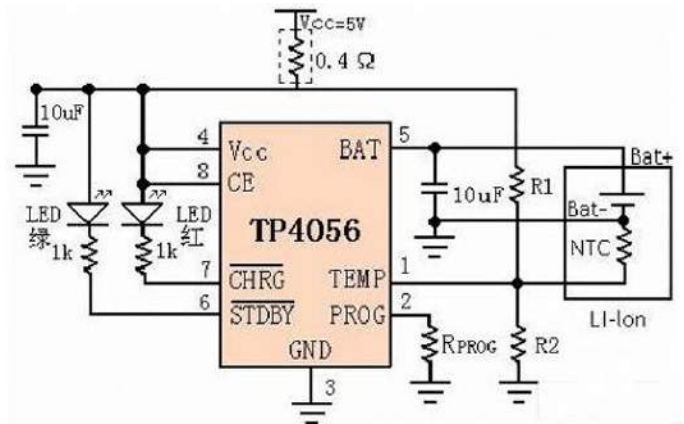
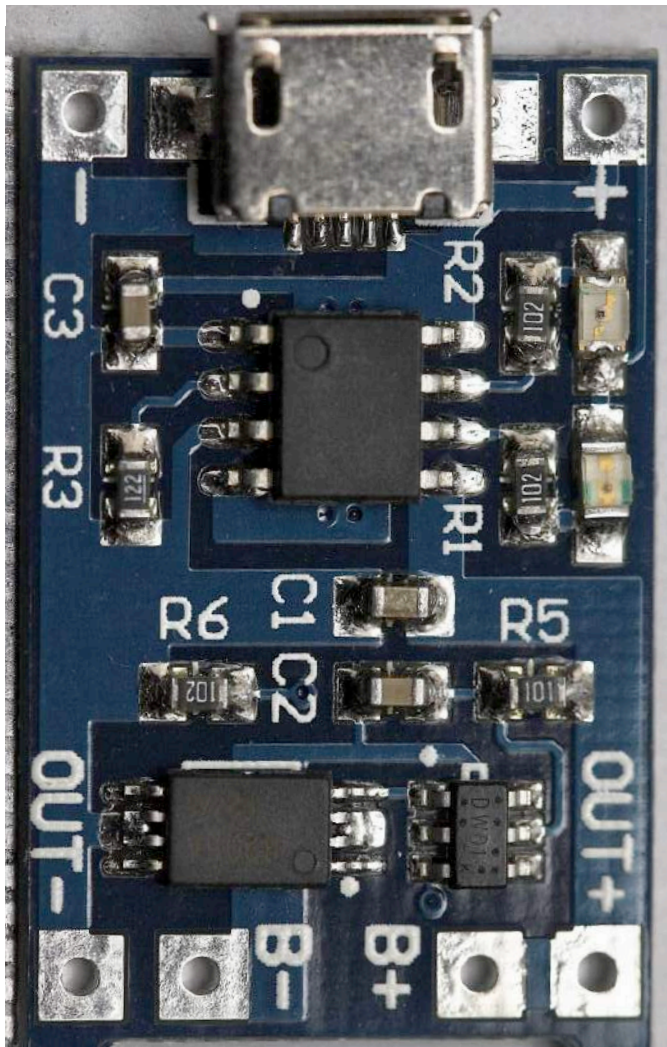

← TIŠTĚNÝ SPOJ NABÍJEČÍHO OBVODU ++ NABÍJEČKA S PŘIPOJENÝM ČLÁNKEM 18650

+ SCHEMA ZAPOJENÍ MIKROPROCESORU TP4056 ZODPOVĚDNÉHO ZA ŘÍZENÍ PRŮBĚHU NABÍJENÍ A VYBIJENÍ

■ Block Diagram

1. S-8205A Series

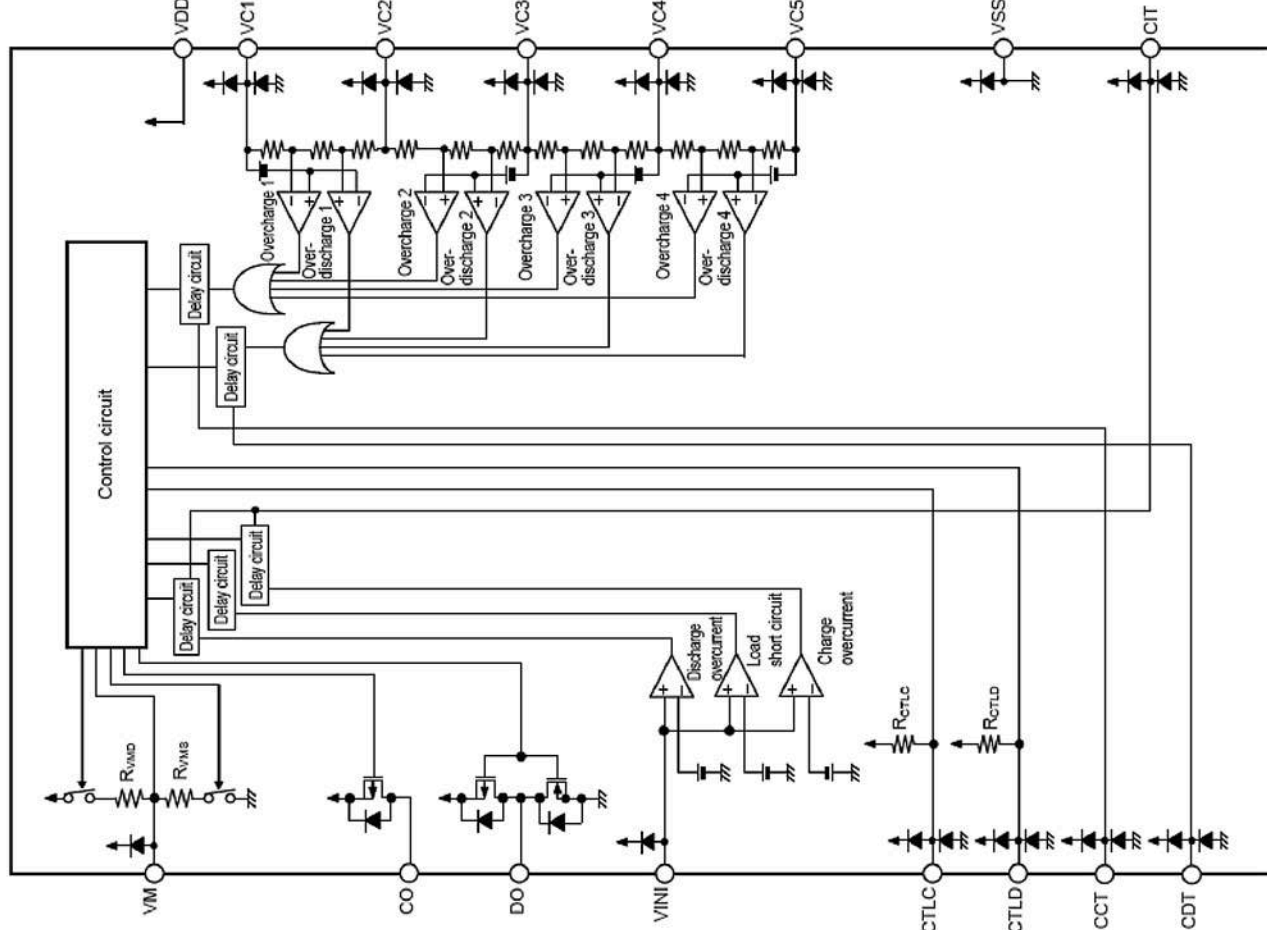

Features & Benefits

- High energy density
- Long stable power and long run time
- Ideal for notebook PCs, boosters, portable devices, etc.

Specifications

Rated capacity ⁽¹⁾	Min. 2700mAh
Capacity ⁽²⁾	Min. 2750mAh Typ. 2900mAh
Nominal voltage	3.6V
Charging	CC-CV, Std. 1925mA, 4.20V, 3.0 hrs
Weight (max.)	46.5 g
Temperature	Charge*: 0 to +45°C Discharge: -20 to +60°C Storage: -20 to +50°C
Energy density ⁽³⁾	Volumetric: 577 Wh/l Gravimetric: 214 Wh/kg

* At temperatures below 10°C, charge at a 0.35C rate.

⁽¹⁾ At 20°C ⁽²⁾ At 25°C ⁽³⁾ Energy density based on bare cell dimensions

Dimensions

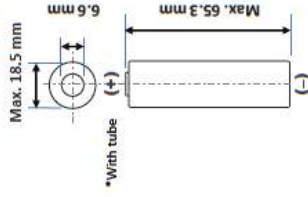

For Reference Only

Charge Characteristics

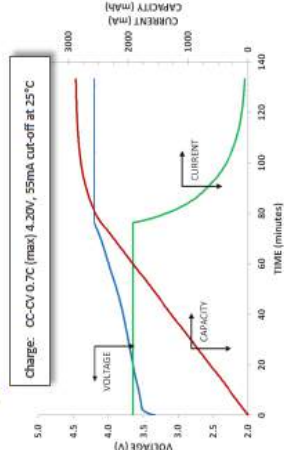

Cycle Life Characteristics

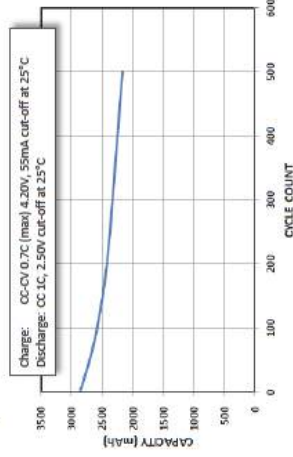

Discharge Characteristics (by temperature)

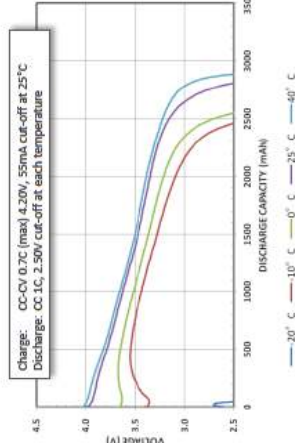

Discharge Characteristics (by rate of discharge)

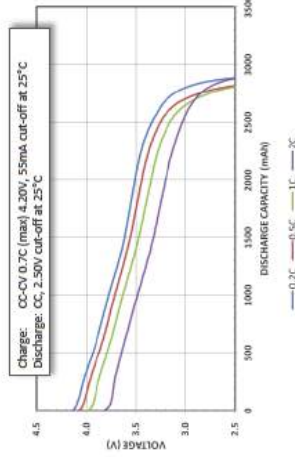

The data in this document is for descriptive purposes only and is not intended to make or imply any guarantee or warranty.

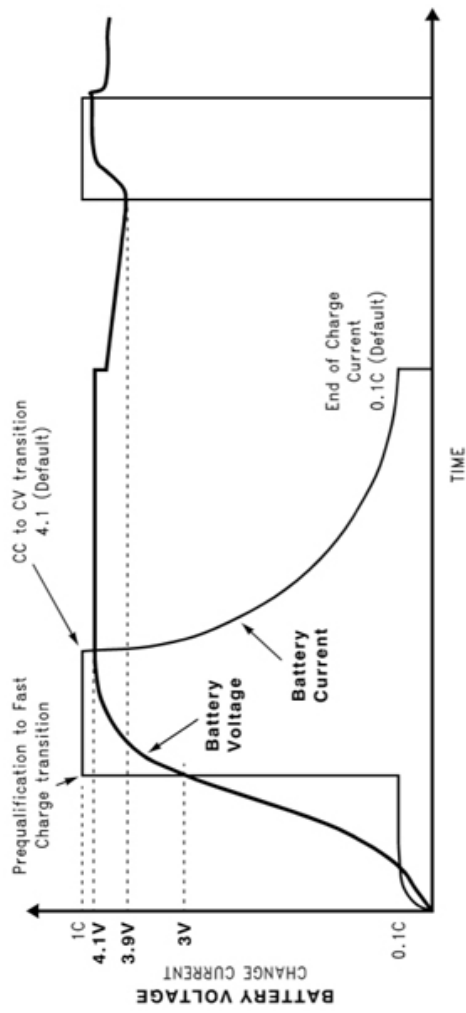

† PODROBNÝ GRAF POPISUJE PRŮBĚH NABÍJENÍ LI-ION ČLÁNKU. VZTAH NAPĚTÍ A DODÁVANÉHO PROUDU A REAKCE NABÍJECKY NA POKLES NAPĚTÍ ČLÁNKU

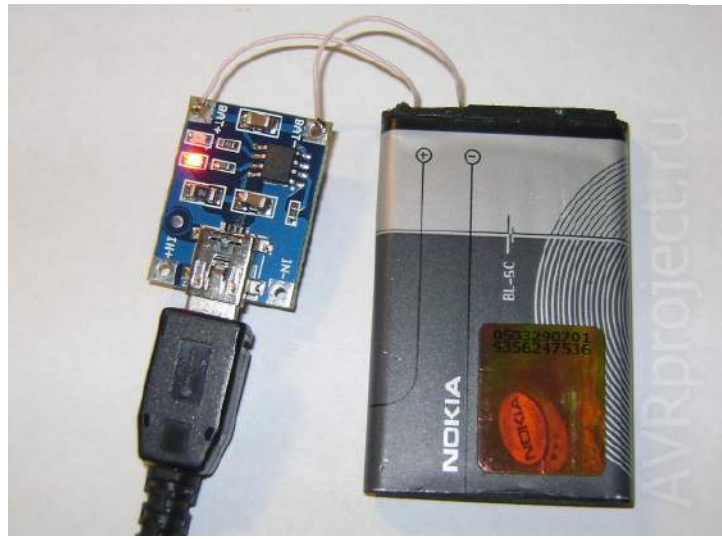

† MIKROPROCESOREM ŘÍZENÁ NABÍJEČKA PEČUJE O SVĚŘENÝ AKUMULÁTOR Z MOBILNÍHO TELEFONU



+ ENERGETICKÁ SCHRÁNKA PRO ČTYŘI PARALELNĚ ZAPOJENÉ ČLÁNKY KOMBINUJE FUNKCI NABÍJEČKY A MĚNÍČE NAPĚTÍ. BALÍČEK JE DOPLŇNĚN MINIATURNÍM VOLTMETREM PRO ODEČTENÍ NAPĚTÍ ČLÁNKŮ



+ JAKUB V. DOBÝVÁ Z NEFUNKČNÍ BATERIE LAPTOPU POUŽITELNÉ ČLÁNKY 18650

4→

DODATEK

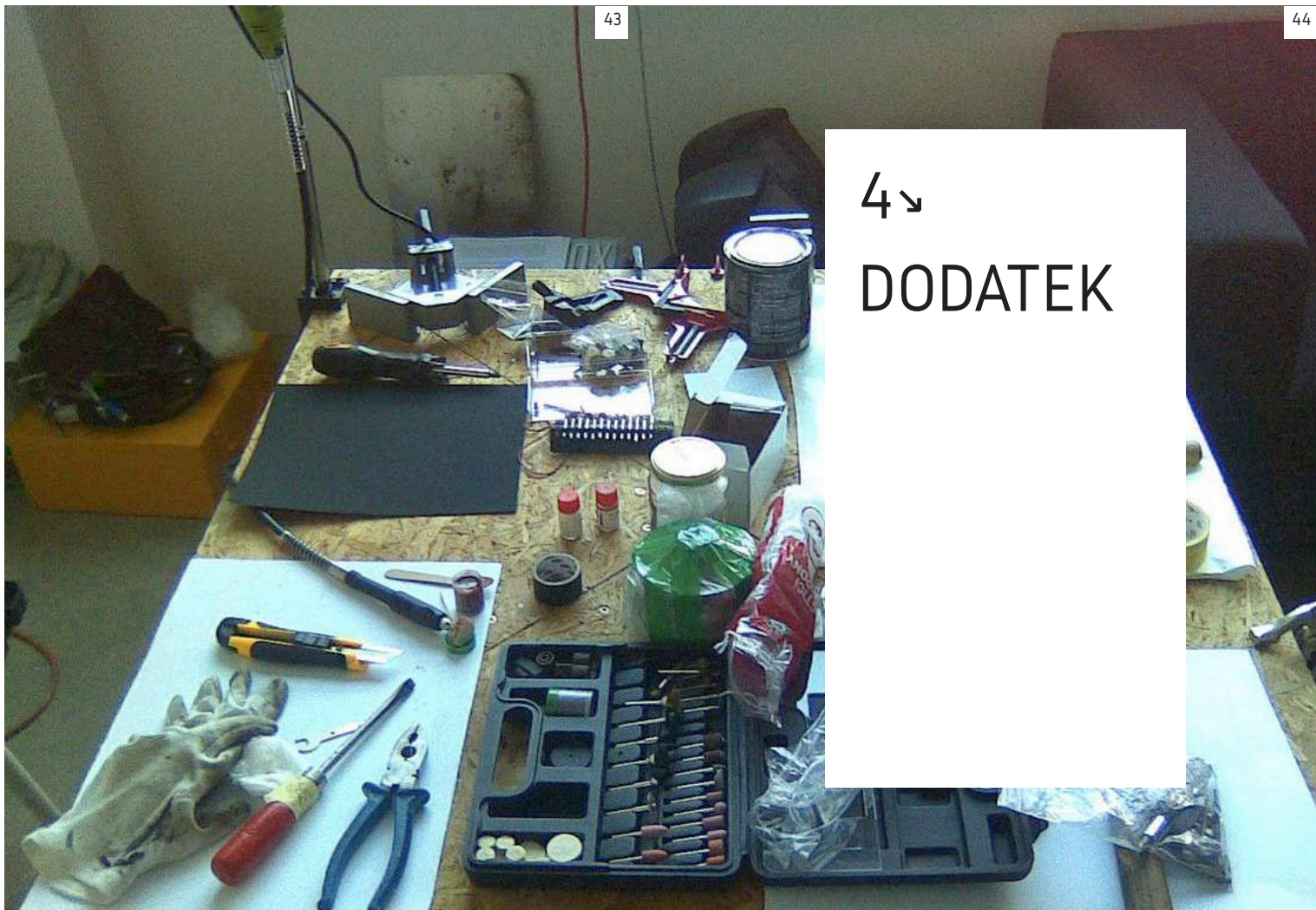

47



+ MISKA OPRAVENÁ METODOU KINTSUGI, POČÁTEK 15. STOLETÍ, JAPONSKO

48

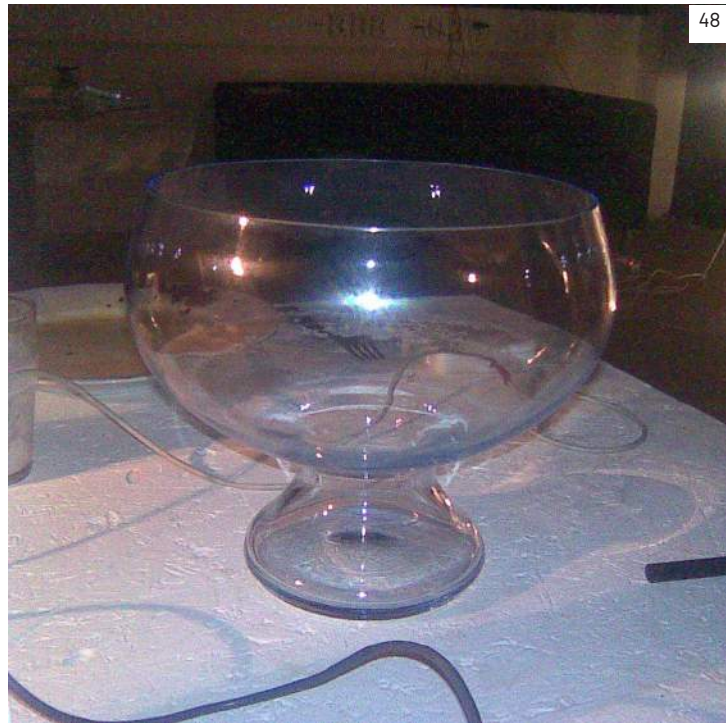

+ VYHOZENÁ VÁZA, NALEZANA U KONTEJNERU, PRAHA 7, ASI 80. LĚTA, 20. STOLETÍ



Expedice RPSP

Rink panelových sídlišť Praha.

Expedice RPSP, Galerie AVU, Praha, 2012



Konečná utopie, vystupovat!

Ve hře VirtualBus A4C/A4E jsem dojel na místo mezi panelové domy. Zastavil, vypnul motor a spustil výstražná světla. Otevřel jsem dveře. Konečná, všichni ven!

Expedice RPSP, Galerie AVU, Praha, 2012



Freezefest a GIF kinokavárna

Projekce GIF a vaření kávy v raketovém odpališti bývalé vojenské základny.

Bratronice u Kladna, 2012



Tajemství lásky

smyčka, 5.30 min.

účinkují

Abba Eban	Jimmy Caqrter
Abdel Rahman Sadek	Jonny Abdu
Abu Ali Shaheen	Joseph Sisco
Abu Jihad	Karim Pakradouni
Abu Mazen	King Hussein
Adel Sabit	Marcelle Ninio
Alexander Hais	Marchal Shazli
Anatoly Dobrynin	Meir Pail
Ariel Sharon	Miriam Eshkol
Ben Zion Cohen	Mohammed Labadi
Benjamin Givli	Mohsein Abdek Khalek
Boutros Boutros-Ghali	Moshe Arens
Clark Clifford	Moshe Dayan
Dean Brown	Mustafa Khalil
Dr. George Habash	Mustafa Tlas
Elliot Richardson	Pogol Akopov
Evgeny Pyrlin	President Numeiry
Ezer Weizman	President Richard Nixon
Ezra Yakhin	Prince Bin Shakir
Faisal Hussein	Ran Peker
Farouk Al-Shar?a	Richard Haass
Fuad Ben Eliezer	Robert Dassa
General Ehud Barak	Robert McNamara
General Fawzi	Saeb Erakat
General Gamasy	Salah Bassuouny
General Gavish	Shafiq Hout
General Haditha	Shams Badran
General Hod	Shimon Peres
General Kirpichenko	Tahr Masri
General Meir Amit	Umm Jihad
General Mitzna	Uzi Narkiss
General Narkiss	Walt Rostow
General Noufal	Yair Zaban
General Reshetnikov	Yasser Abed Rabbo
General Tal	Yitzhak Navon
General Tlas	Yitzhak Rabin
General Weizman	Yitzhak Shamir
General Zeira	Yossi Ben Aharon
George Bush	Zachariah Muhieddin
George Shultz	Zbigniew Brzezinski
Gideon Rafael	Ziamah Divon
Golda Meir	
Hanan Ashrawi	
Hazem Nusseibeh	
Henry Kissinger	
Hermann Eilts	
James Baker	

2012



GIF festival

Festival animovaného formátu GIF skupiny BlackMedia v galerii Entrance

*.GIF festivala, Galerie Entrance, Praha, 2012



Masné stánky

Seznam masných stánků podél Berounky.

K:\>books publikace, 2012



Kukačka v Ostravě

zahájení festivalu Kukačka, projekce GIF

2012, Ostrava



Zavařená měna

Zavařená měna na horší časy. Výstava ceny Exit.

2013



Publikace Kiosk

Kapesní verze publikace Kiosk. A6 formát.

K:\>books publikace, 2013



Průhledná tajemství

Průhledná tajemství AVU.
Laser tisk na pauzovací papír, light box.

2013



Vystřihovánka stánků

Papírová vystřihovánka v měřítku 1:50. Maribor, galerie Kibla.

2013



Maloměstská hlína

Rozhodl jsem se kolem Prahy vysázet zelený kruh z celoročně zelené rostliny. Sazenice jsem přivezl do Prahy z malého města. Břečtan popínavý jsem sázel tak, aby přežil a mohl se rozšířit. Břečtan (Hedera Helix) je dominantní, ale ne invazivní rostlina. V budoucnosti bude vše porostlé břečtanem.

2012



Kiosk

Hardware aplikace pro mobilní galerii Ducato.
Experiment v Neuchâtel a Zurichu v rámci festivalu À la recherche de la bohème perdue.

2013



K:\> nakladatelství

Nakladatelství, které hledá alternativní způsoby vydání a distribuce autorských knih.
<http://www.kbooks.host56.com/>

2013

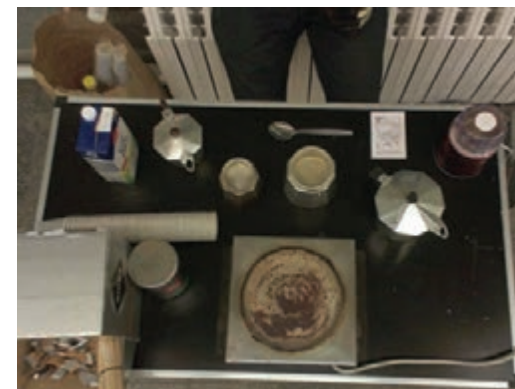

Kofeinizace návštěvníků galerie

Návštěvníkům Kunsthalle Berlin jsem vařil silnou kávu a každému jsem dal lísteček s pořadím jeho šálku.

2013

Viktor Vejvoda

2012→2013

<http://utopia.comlu.com/>
<http://www.ducato.webuda.com/>
<http://www.kbooks.host56.com/>

Viktor Vejvoda

Made in Czechoslovakia

Studia / Studies

Since 2009, studio of New media I. at the Academy of Fine Arts in Prague

2006 – 2009, College of Graphic design Hellichova,
Department of graphic design and print

Výstavy / Exhibition**2013**

Exit 2013, Ústí nad Labem

Byt či nebyt, GAVU

Přídavná spojení II., Kunsthalle Berlin

Benátské Bienále 2014, návrh realizace

(Dis)harmonia, Kibla gallery, Maribor

A la recherche de la bohème perdue, CAN institute,
Neuchatel and Zurich

2012

Expedice RPSP, Galerie AVU, Praha

Gif Festival, Entrance Gallery, Praha

Festival Kukacka, Ostrava

Intruder, Elektrické podniky, Praha

2011

Temná schránka – Dark Case, Gallery AVU, Prague

Přídavná spojení – Additional links, Gallery NTK,
Prague

Intermost – Elusive Intimacy, Gallery K4 Praha and
Gallery Kaffistofa, Reykjavík,

[A]FEFV - [KUL•] Festival experimentalneho filma i
videa festival, Krk

Misliti kot godz, Forma Viva, Maribo, Slovenia

2010

Dataism, klub Final, Praha

Fluidum, Ø8Ø9Ø1Ø, galerie K4, Praha

Ontogenie, Brno

Publikace / Publication

Via Baltica, with Aleksi Cavaillez, publ. Noir sur

Blanc, Paris, 2006

East:West, 1:0, 2009

Drevo, 2011

PPP, Poetická politická pohádka, 2012

Mastne stanky, 2012

Kiosk, 2013

viktorhelp@seznam.cz

+774 806 059

utopia.comlu.com

ducato.webuda.com



Ø8Ø9Ø1Ø | Set of 5×3 books

Project working with photographs of 5 different authors which are systematized into chronological order. Viewer can experience reading on same time level between books of different authors and build up story. Images are no more buried on HDD of their authors, they are materialized and obtain new kind of interactivity, which is not typical for printed medium.

*Work is realised by Viktor Vejvoda and Jan Maštera
Invited participants are Adéla Kremplová, Iveta Schovancová
and Matěj Pavlík.*



Exhumation | *video clip 7'55"*

<http://www.vimeo.com/user4966699/videos>

Exhumation video is based on criticism and exploration of new media technologies and media critical approach.

New technologies have made huge steps in technology evolution. But what happen with human? Are we already not able to understand tools and equipments which we using every day?

Is human kind still master or slave of its own technology?

As grave robber in Egyptian pyramid I try to discover what kind of treasure is hidden in modern data tombs.

What is secret of modern technology crypts?

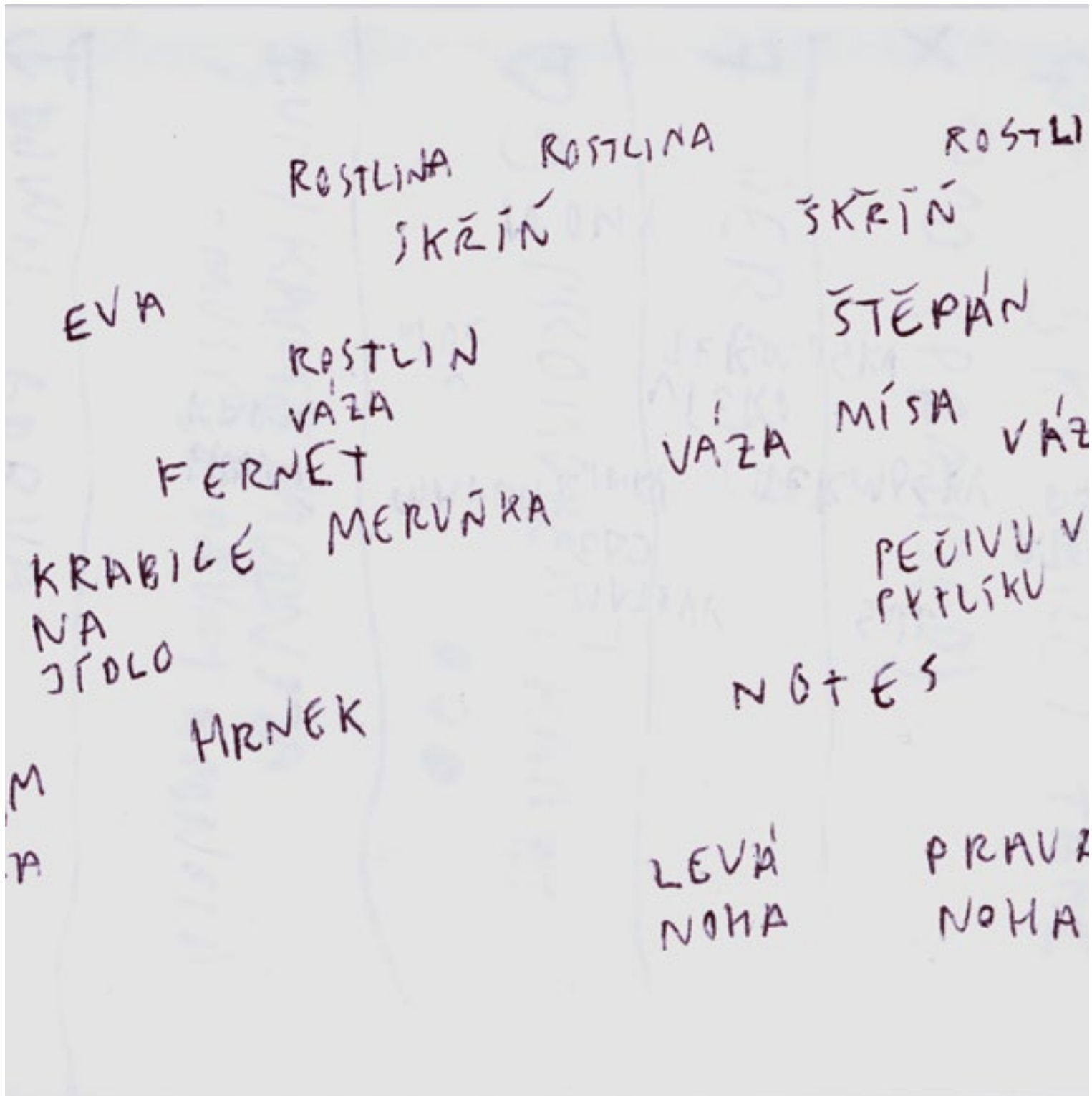

Cogitative Photography of Ordinary | *prints*

Photography which were created with absence of apparatus (as Vilém Flusser refer to complicated instrument designed for creating technical images)
The sets of photography present first analogue part of work. The medium of image broadcasted to viewer is just idea (thought).



Long-distance Call | *video loop 3'35"*

<http://www.vimeo.com/user4966699/videos>

Mysterious dialogue of author together with ears of a dead man. Sonically is dialogue held on same level of sound as is audio feedback hearable (also known as the Larsen effect after the Danish scientist, Søren Larsen).

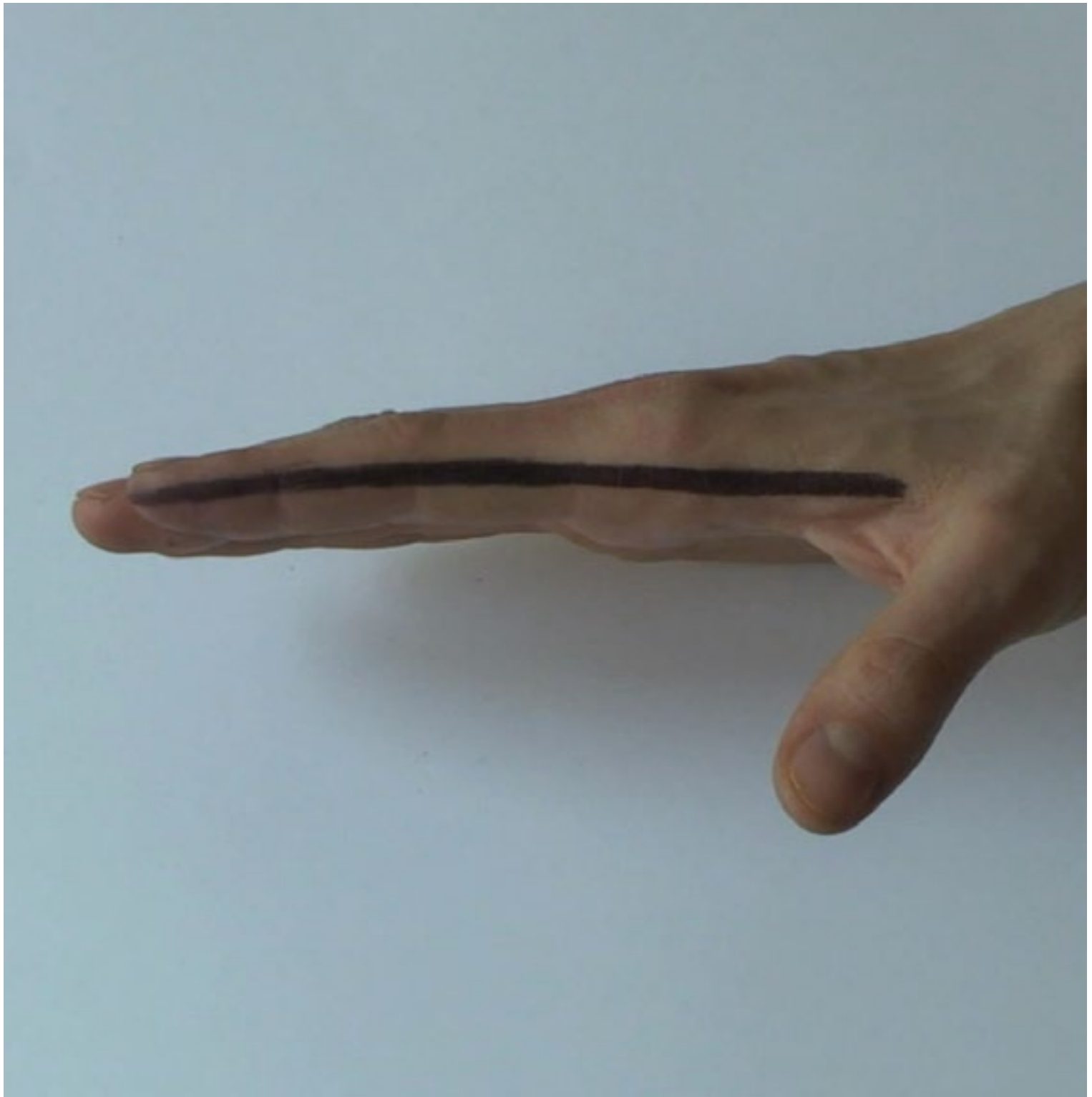

Meta Code | *video loop 2'41"*

<http://www.vimeo.com/user4966699/videos>

Text (meta code) of « Image [1st level]

Image (meta code) of « Text [2nd level]

Visual essay about possibility of changing from linear perception to circular perception. Jumping in one small gesture from linear historical perception of time into circular magical time. About circular magical time contrary to linear historical time and perception is speaking Vilém Flusser in his essays. And they have been reference for this work.

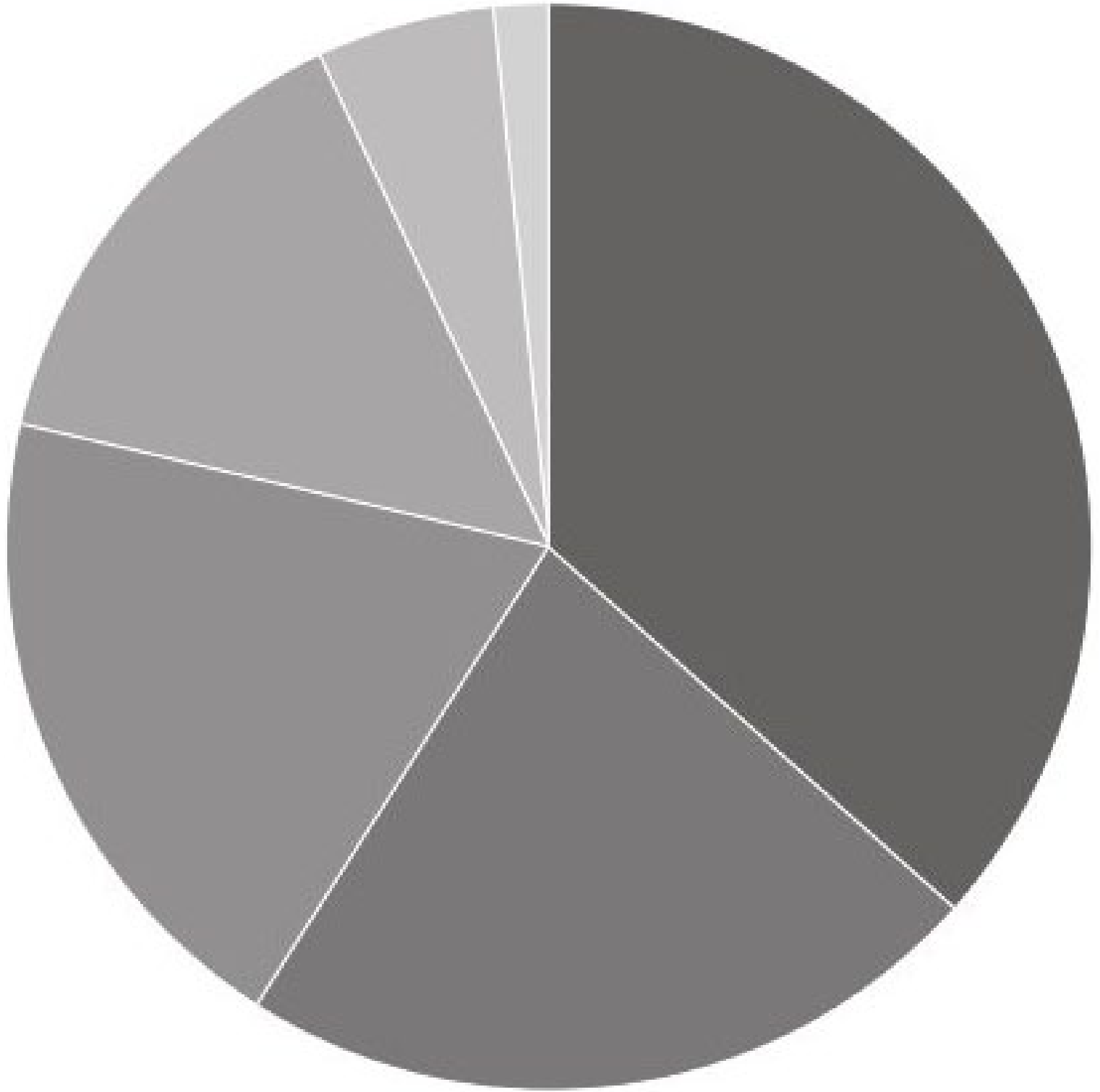

Cake–abstract statistics | *laser prints*

Statical auto–portrait about value and price with abstract visualization. This work is evaluative question about way how humans work is evaluated. Comparing, counting and lining-up things can lead to interesting abstract outcomes: it´s the artist who is most affordable!

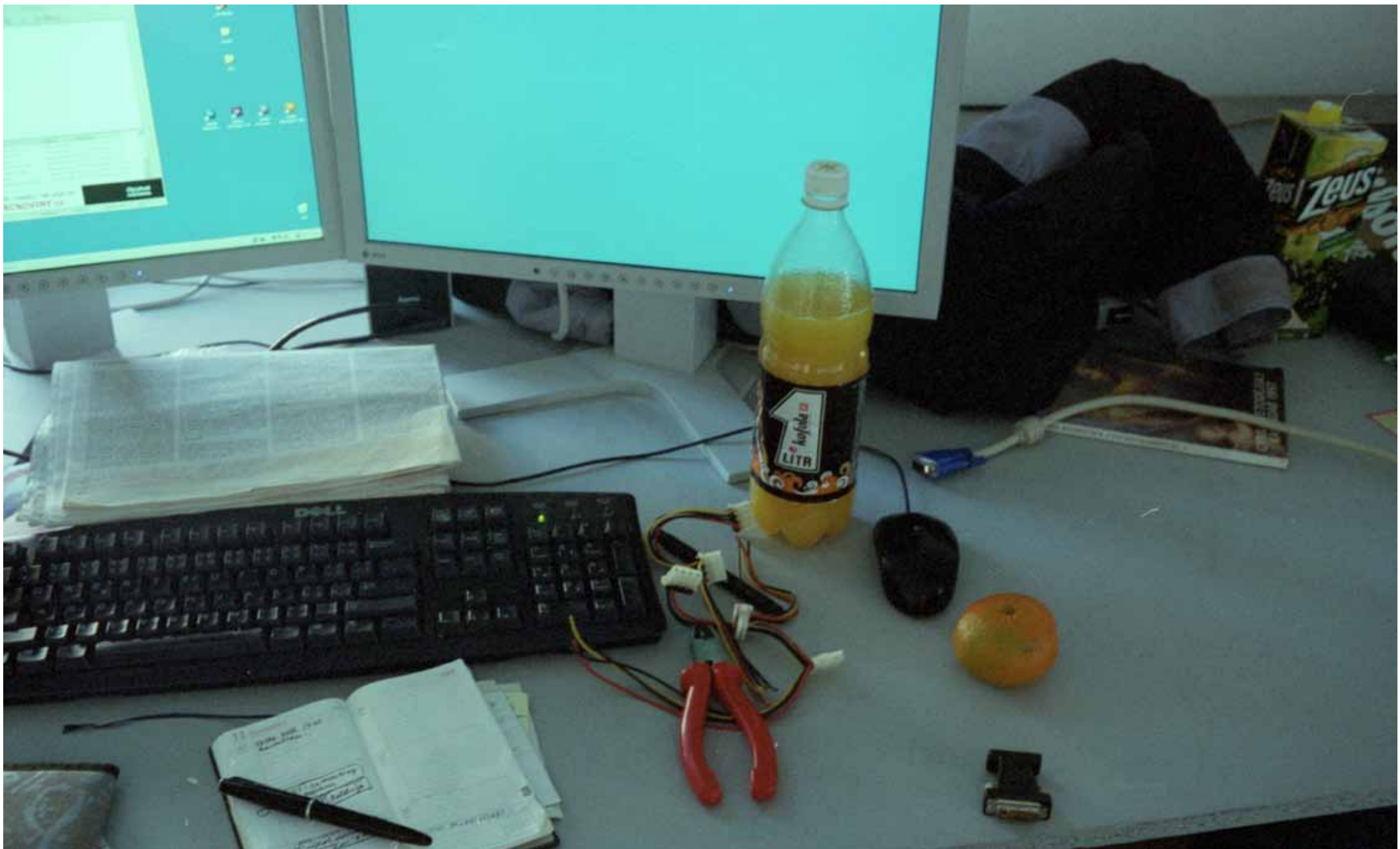

Viktor Vejvoda

09 — 10



B for Bike

This is one of my longer term projects. Aimed to material thing such a bike is. I want to promote another point of transportation to larger amount of people around me. As I experienced by changing of tool I can get complete different results. The change of perception of a landscape and its details was significant. Personally the effect was as high as if one would start to look at the objects around him using hands instead of eye. In order to explore tools function in society (bikes function), I have chosen most odd, unneeded and outdated bike, which you can find for free in scrap metal or buy for about 10 euro. Then I began to promote drastically bike to everyone around me, showing pictures made in style of product photography, writing about it and also giving my personal example by using the bike and going on it everywhere as much as possible. It was remarkable to observe how these primitive strategies of advertisement works in real life and how bike is being step by step promoted to near people. Finally we made international trip through Germany to ex-DDR beaches. It was interesting also to compare reaction of people to our transportation tools. In bigger Czech cities was reaction neutral and tolerant in opposition to Czech countryside where we got sometimes negatively commented as riding something socially unacceptable. Or we were target of silly jokes of sort like "My grandma was riding this".

In Germany we were mostly not commented at all even in small towns. In some places were bikes evoking nostalgia connected to years around 1980. In some countryside regions of both countries we have also met such a bikes.

Counting them on a way Prague – North Sea we have come to number 17.



East beats west, 1:0

My authorial book summarizing inspection trips to Eastern countries. Countries which were inspected were Romania, Ukraine and Bulgaria. I wanted to produce publication standing in completely opposition to Tourist guides. Trips were completely unplanned and chaotic in way of its schedule. There for I was always visiting unexpected localities. The rule of chaos created original point of view on each country. Somehow chaos helped to obtain experiences from very particular places which were not mentioned in any accessible tourist guide or information sheet. In book text I reflected assumption about sharp difference between places they were released in any kind of media and places which stay unknown. Other topics are: train as a social institution, caffeine the most spread drug, waste policy of west...



Pictures in the Dark

Idea to realise “Pictures in the Dark” comes from interest into possibility to share and transmit visual information or piece in different way. I was also wondering how to merge transmitted information with surrounding environment so the outcome is original piece. Step by step I came to an act of transmitting picture through sound and backward recording of transmitted sound together with local noises and through spectral analysis obtaining again picture but modified. Because in the form of sound is meaning of coded picture quite latent I am thinking of transmitting sound in public space (radio transmitter) or into space (laser). Giving chance to encode latent meaning to anyone who receives this.

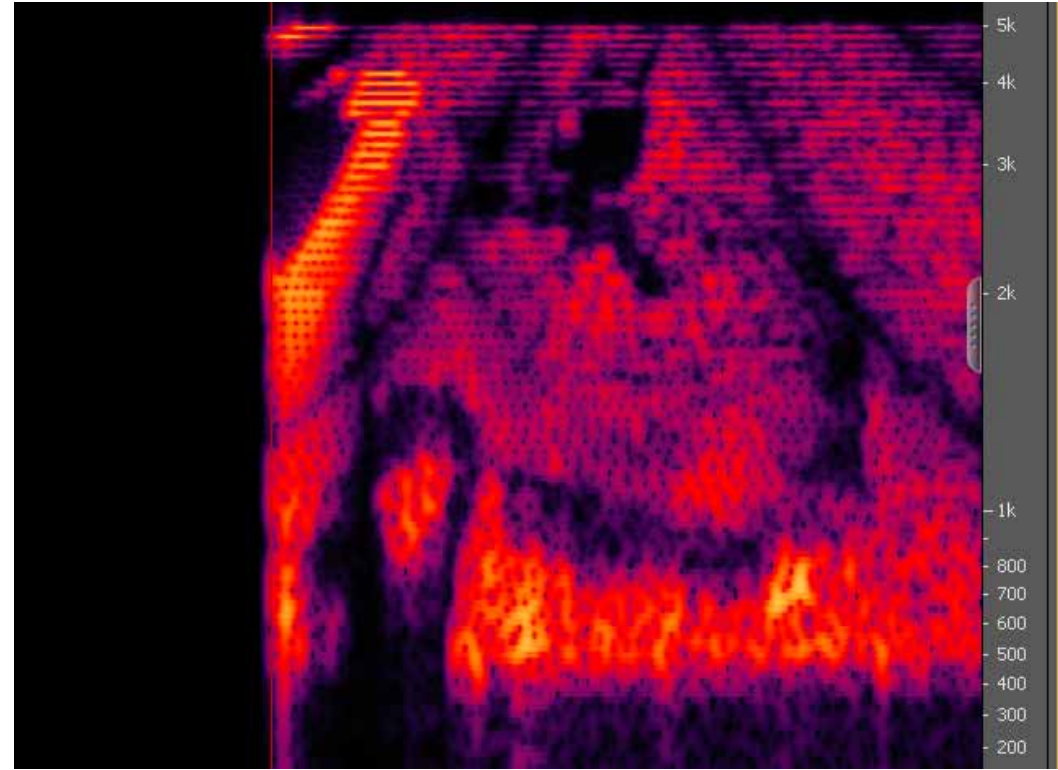

And he disappeared / Flash cut

Everyone has in life some people or elements they slowly vanish out of ones life. To depict those, who left my life I used brutal flash exposure, which burned RGB values up to: R: 255, G: 255, B: 255 (pure white). Uncovering tricky character of photography I used small paper silhouettes to flash on. What would not be possible in real life (for example cover huge house with paper to hide it) it's really simple if photo camera is used. I was amazed by violent possibilities of modifying photographs scene standing in contrast to sneaky Photoshop editing used in most cases. Light can tear in parts!

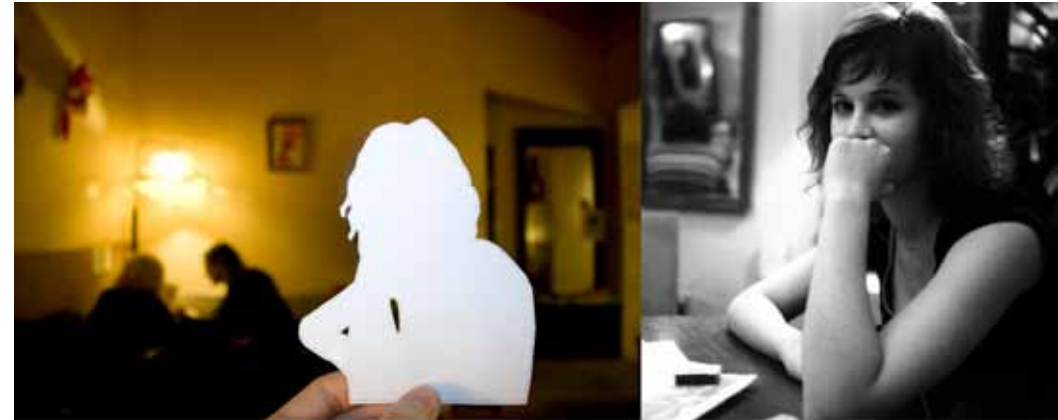

Arjo
Viděl jsem ti zpodobit před sebou.
Nevím, kam tě je po Hellaru
Málo tě vidělo na výhled.

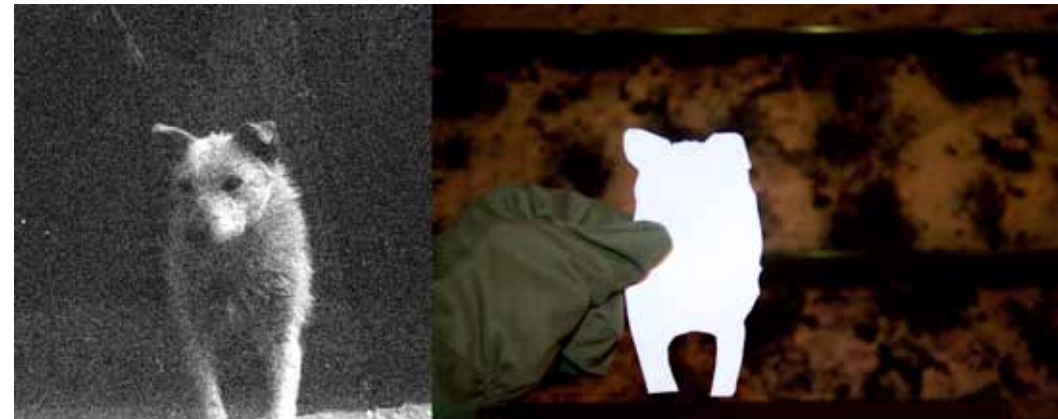

Pes na náhledě v rozmanitých odětech (Zdraví)
Pes na nové bundě.
Mohl jsem tě fotovat jako na první školní a školní
Mohl jsem tě fotovat jako na první školní a školní



Prophecy

I would like to write all things which I consider that might be and may happen or not in future. Than I would let it read by somebody loud to the camera. Edit it. Burn it on stable CD with golden surface which is guarantee to last at least 100 years and safely packed hide it or dig in to soil. At least one of my sentences would happen in future and after discovery of my CD I would be considered as a prophet. This would be wrong because prophecy is just question of statistic and interpretation of written so call prophecy.

Welded molecule

For this "installation" I would like to synthesize together 3D models of molecules, Welded models of molecules (maybe combined all together [in 3D programme]) and theoretical content of 3 substances: caffeine, hydrocarbon and alcohol. I wish to be able think and work with those molecules in all 3 attitudes as a model in cyberspace, real durable model produced from metal and hypothetical models and relations in my mind. I would be happy if outcome of this idea is place where you can play with my real big welded molecules, place them according one's preferences or warn people in what mood one is. But also in same place read links and facts about these molecules (maybe listen song about them) and finally (in same time) watch 3D outcome as an animation. I like that the chosen molecules symbolize modern-days consumption and speeded-up lifestyle as well as spiritual traditions of more than one culture. If I put carbohydrate in middle (human molecule), on sides I end up with molecule of alcohol typical for Christian Culture and on the other side Caffeine typical for Arabic or far Eastern culture. Carbohydrate plays main role in human body (one of 4 bio molecules) as a transporter of energy (alcohol, coff.) and it is responsible for bloods clotting. Which brings my mind back to bibles quotation: In whom we have salvation through his blood. I'm sure afterwards during work on my topic I can find much more links between these molecules.

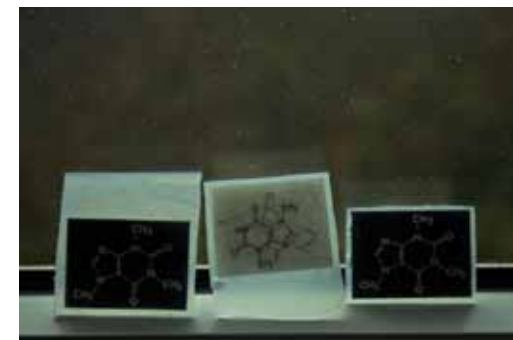
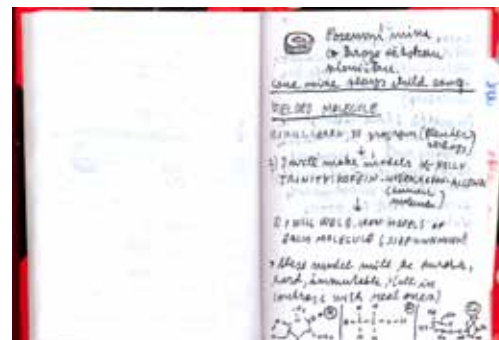

Print my cover!

Archaeology trip to Low-Tech technologies of 1990s. I found really exiting to use old unwanted technology to realize my ideas. I become found of this kind of naïve and inoffensive technology, as it seems with comparison to contemporary equipment. I would like to programme and use old computer and old dot matrix printer to be able print instantly on demand of user. Originally I wanted to design and edit quotations from my favourite's books, but I found later this topic too serious and expositing so I decided to aim on trash literature. So I would like to print covers of junk paperbacks, which naïve style of typography and content I admire. I don't know about copyrights for the covers, but my prints would be so low end, that I guess nobody minds.

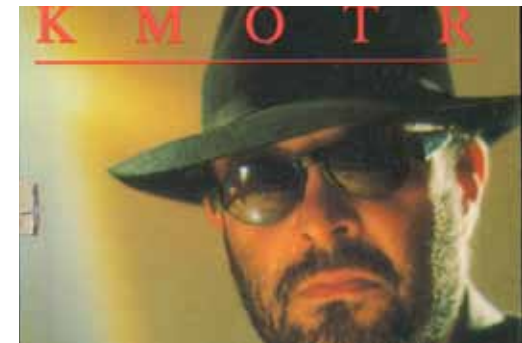

Airport

Idea which is meant to be realized in landscape in Prague neighbourhood. First I'm going to describe how I came to this theme:

1st I was thinking about short amateur movie of my friend. It was just usual movie from some party. But all people there were strange frozen and facing like zombies. I realized it was because he was filming with Photo-camera with possibility of shooting movie. But everyone was expecting he is taking picture. So from here comes this rigidity!

2nd It often happen to me during watching some movie, I imagine what is going on behind camera. I see best boy, camera operators, and people throwing chickens into scene (in Western) or pieces of material (blow up scene). These thought can be really disturbing.

3rd I like flash. It's small and it makes light. But I never had seen flash as a main object of photograph. Well sometimes in sport photography you can see pieces of flash stands and reflections. But that's all. My goal is to bring photoflash into centre of interest of camera. (And best video camera not photo camera to use this cross tool effect (the freezing people in front of camera, photography flash in video footage)

So finally I would like to build autonomous flash unit out of some trash. It would be necessary to program it and be able to produce them in amount of at least 10 pieces. This unit must be possible to synchronize and I'm thinking also about mode, which flash unit, when human is standing near to. (Something like light mine)

Application of units would be as I said in open space. I have in my mind two light scenarios for nature.

Airport. Would be timed flashes in space, evoking airport. Airport symbolizing nearly military organized object with antiseptical atmosphere. Full of rules and prohibitions. Equipped with CCTV cameras watching everything. And allowing flying away just the ones who have all papers in order and have enough financial resources to afford ticket. Because one human has had always dream of flying and of freedom I would build my own toy airport in fields. It would flash as well as real runway. This act has for me subversive idea and parody content. But it's also connected to famous interpretations of western tools by primitive nations in equatorial areas.

Flash cut is second usage of flash tool. Using flash as an object seems to me like act of transposition. To see, what is supposed to be hidden. (Same experience I have seeing rabbits furs, killed by my grandfather, drying with fur inwards and pink skin outwards) It would make just one striking flash line into landscape. Cutting light parts out of dark. For me light symbolize illumination, enlightening as well as light from blow, police flash bang. All this I would like to bring to attention of camera. In movie would meet principal of movie (continuous catching of action) with principal of photo (in this case on huge light in landscape). The light would be small artificial lightning, if everything works well.



Uncovering liars

Edition of stickers with theme of “photoshoped” and “edited” to mark obviously edited photography used in public advertisement.

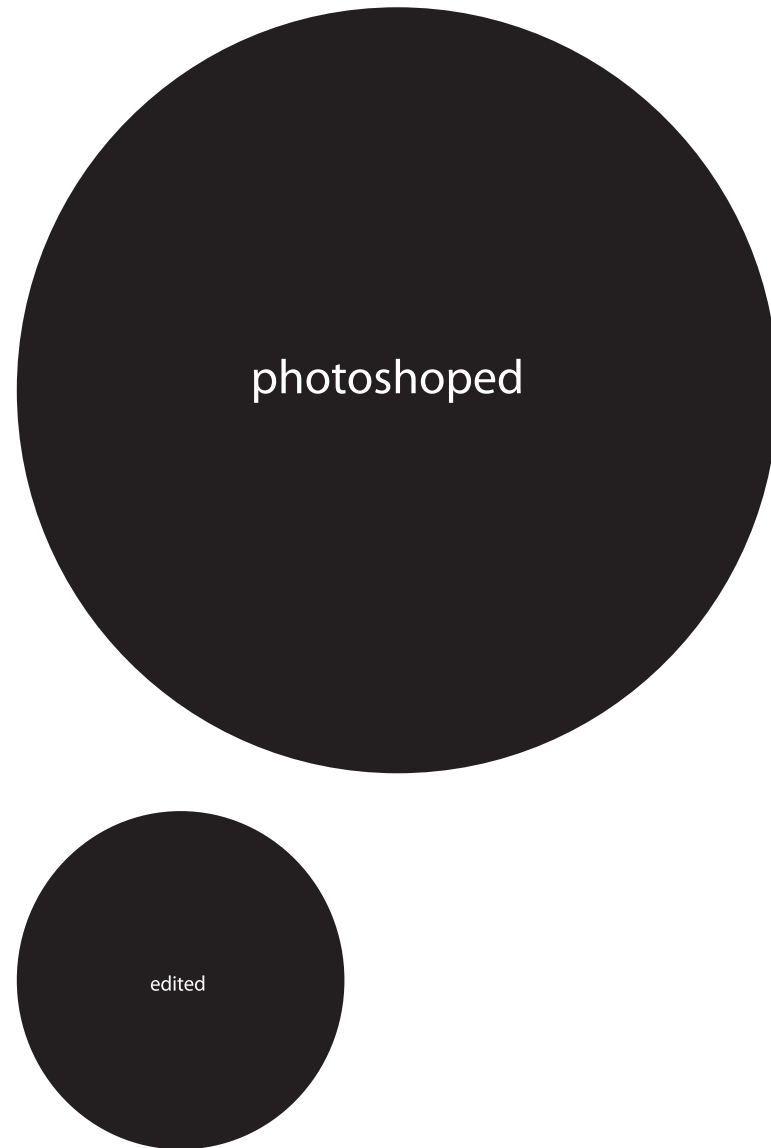

Sub-machine strings

Object joining what can be described as karma of weapon. Thinking of this I come to conclusion that plastic cup, pen or sandwich. The weapon comes from strange group of things which bring emotional excitement because it's violent denotation. I would like to explore this hidden emotional request inside of such a things on audience and on myself. For example it's famous fact that modern armed conflicts where children's army was participating was caused by the fact that weapons got lighter, so kids were able to carry them. Where is then slight border between weapon and toy? What it would change if I would colour weapons as a toys? Will the negative feeling remain, or will be such an artefact perceived as something harmless. Because I feel un-expressed existence of weapons in our demilitarized society. I planned this topic into 3 catharsis phases.

1st 3 or 4 guns moved to colour of media in which from which we know them (RGB for TV or CMYK for print) from the colour scheme it would be 3 or 4 pieces of weapons. With ideology and motivation I described above. Maybe containig link to criticism of scary spread accesibility of weapons in general.

2nd I found out that mortar mine have really similar feeling as vase or some interior decoration. I would like to find places, where this dangerous thing would stand as a still object creating tension between calm and drastic. Symbiosis with mine and me would be presented as photographs. With memory to all people who have to live in mine areas.

3rd (hypothetical) is connected with fact, that there are some things which are nearly indestructible. I would like to create such a place, shelter for people with help of armoured car. On surface metal and hard, inside with added plush surface to be soft and cosy. Standing on place as a statue, which is possible visit. Ment to be opposit what such a car is made for in its origin.

Caffeine Bomb

I'm living in culture of Caffeine. I tend to track caffeine sources also according its smell. Therefore I would like to explore options of installation which is based on olfactory sense. Reactions for such an art piece would be also notable, because perception of such an expression would be subconscious, latent but also unavoidable. The smell would mix with public space, gallery room and even with other art pieces. This work would balance on gesture of smell instead of any audio-visual message with possible subconscious effect leading to need of coffee.

Other installation scheme would be in technically nasty and inhospitable place, where would be visitors confused with smell of café, which is medially linked to feeling such as comfort, relaxation or rest. But in modern city life can be this smell associated with rush, overtime, insomnia and loads of work.

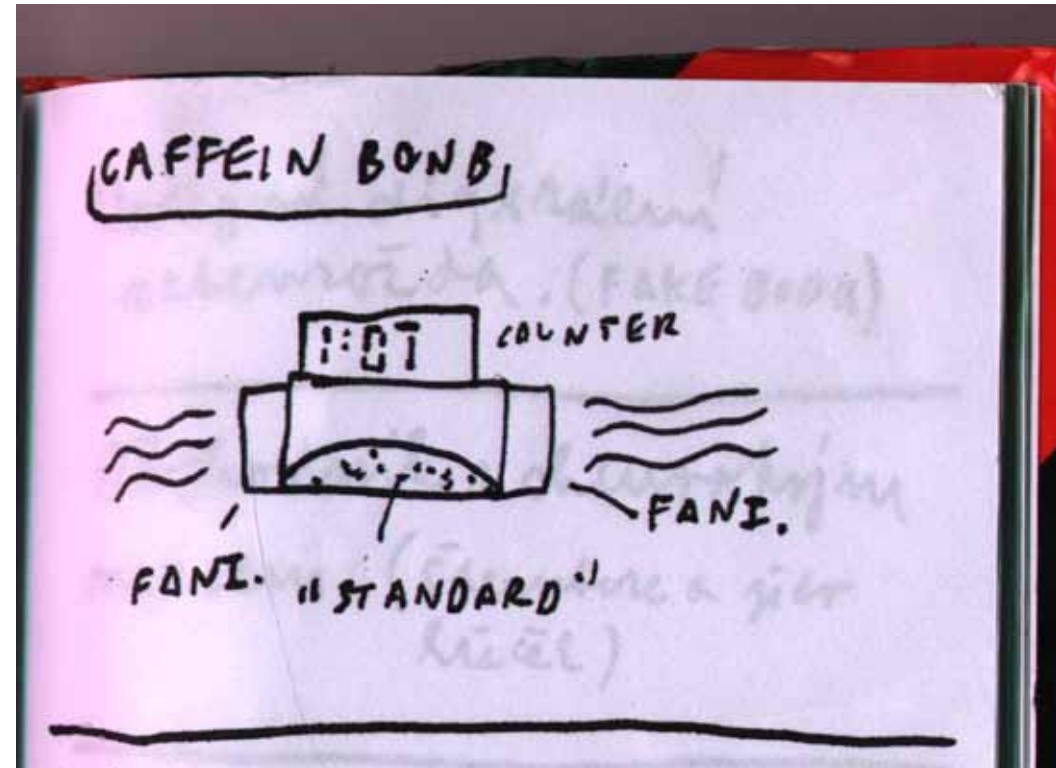

Notice board

Social constructive project. Dealing with context of data flow situation on the Academy of fine Arts. As object to aim on I have chosen notice boards where are important information for student been physically presented as a printouts. In most case being found too late to be still valid and important for recipients. I was trying actively help to solve this situation and negotiate with studies department with no effect. In time I was trying to find solution for such an situation, where important information are get-at-able just physically inside school I realized magical function of Notice board and it's purpose to carry on information coming from different sources in chaotic order. Act of transformation information from digital to analogue and again to digital seems for me magical and mysterious in its irrational repetition. To transmit this notice board situation I would like to use web cam aimed on the board and domain where visitor can see current situation. Finally I have bypassed problem of data sharing inside school which is hard to solve and is and subject for me. Together with this is created ANALOGUE – DIGITAL transforming place, giving opportunity for small performances and declamations.



Tracked T-shirt

I observed a second hand clothing market in Czech and compared it with donations to charity in the West. I came to conclusion that part of clothes is being collected as a charity in Western countries and than transferred to East, where clothes are sold in second hand shops with profit. I believe this market is well organized and covered by infrastructure of some kind of organisation. I was haunting for some traces in pockets, but only thing I have ever found was a franc coin in corduroy trousers a year ago. Trace is that on lot second hand sold clothes are missing brands. Mostly they are professionally removed. I believe, it would be possible to uncover whole system of such a market by finding first owner with help of social network and re-compose history of particular cloth. I hope so, because some brands are specific and worn by quiet small social groups. Project also aim on fact that things which are in one place evaluate as unwanted, old-fashioned, worn out and are in other places sold again and used for some more time. Also total amount of financial spend for every piece of cloth is growing (original price + second hand price) which leads to interesting money flows.

Things around me.

Quotations of things happening around me.
Frozen and packed into A4 paper.

**Rozšlápnutá hranolka na cestě tam.
Rozšlápnutá hranolka na cestě zpátky.**
12.12.2009, Můstek

Ten toustový chleba tam někde musí být.
19.1.2010, Kamenická / 12:52

Nedávej pusu tomu sedadlu.
26.1.2010, Pavelkova / 20:32

More, kdybych měl internet, tak už si s ní píšu.
5.4.2010, I.P. Pavlova / 19.30

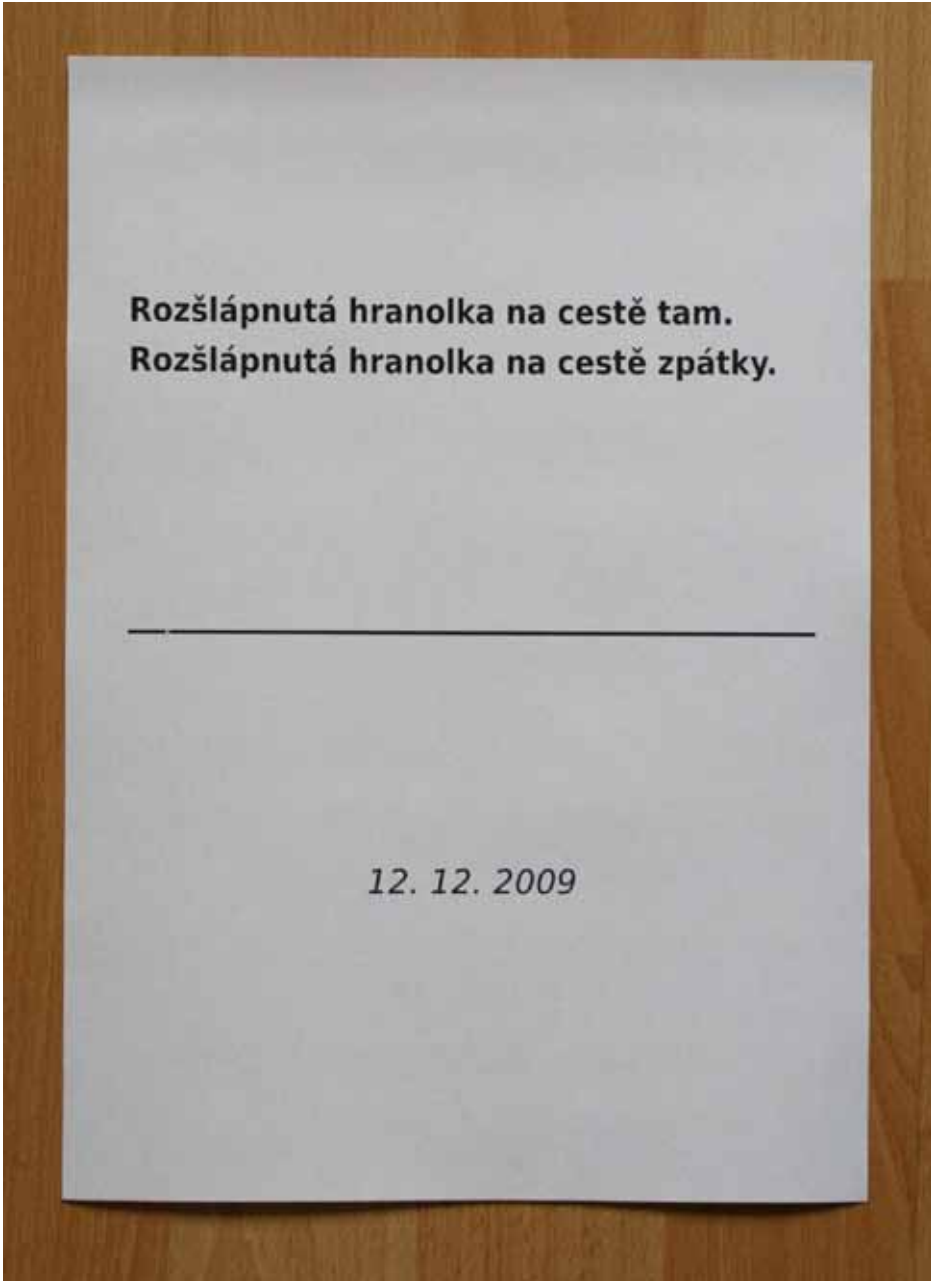

**Rozšlápnutá hranolka na cestě tam.
Rozšlápnutá hranolka na cestě zpátky.**

12. 12. 2009

Dog

A dog trained to be able sniff out money. Dog will be given some reward (goody) if money is founded. Animal will be introduced to system of human values. If the dog is well trained, he would look for money all the time and perhaps bring interesting disruptive situation.

Laser cut

Laser ray long 566m. Source of laser was taken out of DVD burner. It create visual cut into ordinary daily view.



2min 53sec. video in bus 253 of swearing man,
who is not visible at all.



Small animals

Night shot of haunting small animals in suburb area.



Light

This work symbolise for me non-violent form of subversive action. Flash is archetypically connected to photography as a tool which helps to light up what is being photographed. I'm using flash (more precisely light by itself) as an object in front of cameras.

As an object of interest. Light emitted by light units means for me representation of wild energy. Experience of such a light blow can be described as an experience with natural energy such a lightning or in mythological way as energy to clean up mind or even enlightenment energy. But it is also possible to perceive such a light explosions as an icon for negative energy created by human kind (explosions, police anti-riots flash bangs). Recorded flash also tears visual image of place into something different and shows hidden points of view. Such a light blow is gesture in open space, which tears reality into 2parts (before –after) and can be perceived from far distance with different interpretations by the viewer.

Group of 10 light units. Units are able to emit strong beams of light. Every unity consists of flash tube, electronic controller and battery. Units also contain of capacitor which charge up to 330 volts. Because of this units should be manipulated with care, by informed person. Control is maintained by wire, which is plugged into each of the unit. System is possible to connect to detector of movement. Version of Light 1.2 should be able to emit time programmed light beams. Beam is strong enough to be visible from far distance or from airplane flying in low altitude. Although emitted light is strong, it's not able harm human eye sight. But long and near exposure by the light is not recommended.

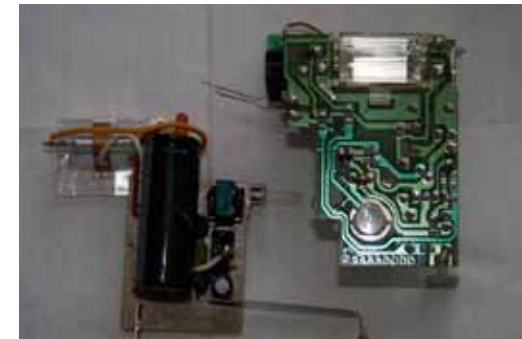

Killer

This video is dealing with role of TV in public space and in private life. TV screen is attracting most attention because it emits noise moving pictures. There is also huge pollution of these moving pictures used in shop windows, waiting rooms at hospital, pubs, public corridors etc.

For example pub was originally interface for people to share ideas, problems and dreams. But from time when mostly oll pubs contains screaming TV, people discuss nor nothing and pay full attention to TV or they discuss topic offered to them by TV.

I assume that it's impossible for people to think and act inventively if their space is already filled up to roof with medial contamination produced not only by TV.

I decided to kill the killer. With help of small remote control which is sending all known brand Infra Red order: Switch Off. There are over 4000 Infra Red codes for this order and some are unknown. So it happens that my assassination is not always successful.



Soy Wall

I bought bottle of soy sauce. Tasting it, brought my mind to question about interpretation of others culture in home culture. How and what are we imagining about countries and people far away from place where we live. Are we having realistic point of view or is all we tend to imagine just fiction? Are food rituals which we connect with other cultures and we practise theme in Europe just as well fictive? What is real reality? And for whom is reality more real and for whom less.

Project is based on long discussions about China with European traveller. (which is also raising question if tourism or travelling can bring overview on different cultures at all, in case its still just part of GDP and in a way industry.

Piece consisting of: painting (1,5x4m), video interview and GPS navigated land-art installation.

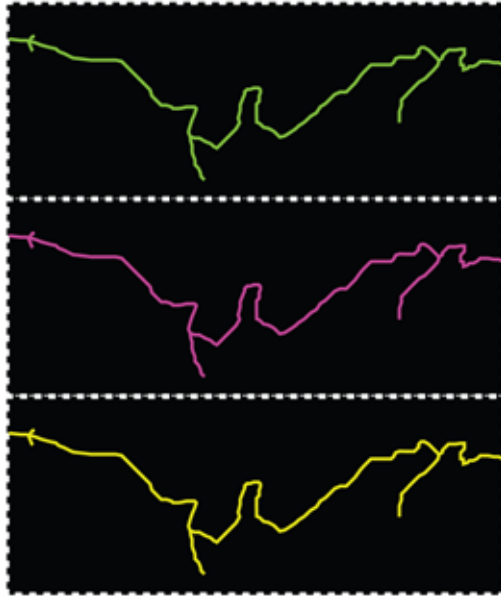

2,5 GHz

Research in invisible sphere of frequency 2,5 GHz. This frequency is determined for wireless network connections. Coverage of landscape and urban areas with these sites are much more frequent with expanding technicalization of society.

I deal with data capturing and interpreting of names and relations of Access points. I pointed my intention to see the life routines (time of on/off mode of AP), minority names of AP's, AP's names with sexual undertone, factory settings of AP's, vulgar AP's names.

Data capturing is made by walking in area of interest. Next possibility of data capturing is train journey.

Outcome of research would be catalogue list of AP with map, from which is possible read context of individual APs.

Realization would be done as a machine cut graphics applied right on place of presentation.

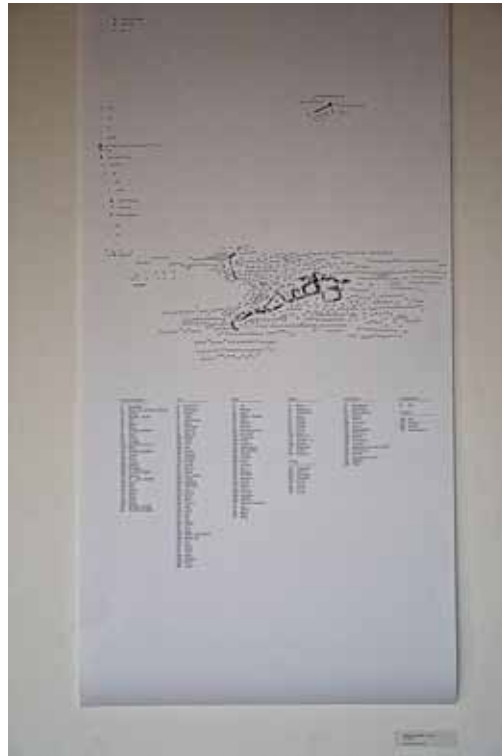

234	infrastructure	PRAHA4NET.CZ-R26-0	00:0c:42:2c:b9:ed	1	No	None	No	0	0
235	infrastructure	miazgovci	00:21:63:f0:43:69	1	No	WEP	No	0	0
236	infrastructure	VOIP	00:24:d2:3d:b9:d7	1	No	WEP	No	0	0
237	infrastructure	CZF.Dvorce.1	00:15:6d:a6:87:91	7	No	None	No	0	0
238	infrastructure	Lukas	00:02:cf:55:03:a8	4	No	None	No	0	0
239	infrastructure	SOHO	00:0e:2e:d9:e2:7e	2	No	None	No	0	0
240	infrastructure	NoName-001e7a17e390	00:1e:7a:17:e3:90	13	No	WEP	No	0	0
241	infrastructure	Wireless	00:11:6b:14:71:4a	3	No	None	No	0	0
242	infrastructure	default	00:02:cf:4b:05:92	6	No	None	No	0	0
243	infrastructure	VOIP	00:24:d2:3d:65:c1	1	No	WEP	No	0	0
244	infrastructure	VW Fany	00:24:d2:3d:65:c0	1	No	WEP	No	0	0
245	infrastructure	VOIP	00:21:63:38:86:e7	1	No	WEP	No	0	0
246	infrastructure	FROG	00:21:63:38:86:e6	1	No	WEP	No	0	0
247	infrastructure	NoName-001bfc7854f9	00:1b:fc:78:54:f9	1	No	WEP	No	0	0
248	infrastructure	fuchtle	00:02:72:6c:ae:72	11	No	None	No	0	0
249	infrastructure	nev	00:1e:8c:ce:f5:6c	11	No	WEP,TKIP	No	0	0
250	infrastructure	CGP-WiFi	00:b0:c6:05:57:0f	6	No	WEP	No	0	0
251	infrastructure	VOIP	00:21:63:9b:a8:b1	12	No	WEP	No	0	0
252	infrastructure	VOIP	00:23:f8:8b:b2:7d	4	No	WEP	No	0	0
253	infrastructure	VOIP	00:23:f8:a2:d8:ee	4	No	WEP	No	0	0
254	infrastructure	Akvalp	00:23:f8:a2:d8:ed	4	No	WEP,TKIP	No	0	0
255	infrastructure	VOIP	00:02:cf:b3:dc:f0	13	No	WEP	No	0	0
256	infrastructure	Internet1	00:02:cf:b3:dc:ef	13	No	WEP,TKIP	No	0	0
257	infrastructure	VOIP	00:02:cf:a5:5b:bd	13	No	WEP	No	0	0
258	infrastructure	Internet	00:02:cf:a5:5b:bc	13	No	WEP	No	0	0
259	infrastructure	Zvonicka 12	00:13:64:49:bc:8b	11	No	WEP,TKIP	No	0	0
260	infrastructure	Podoli	00:23:f8:94:49:bc	10	No	WEP,TKIP	No	0	0
261	infrastructure	VOIP	00:23:f8:94:49:bd	10	No	WEP	No	0	0
262	infrastructure	Podoli	00:24:d2:3d:1a:03	1	No	WEP	No	0	0
263	infrastructure	Windy	00:19:5b:1e:4c:5a	6	No	WEP	No	0	0
264	infrastructure	magrathea	00:02:cf:4b:11:02	6	No	WEP,TKIP	No	0	0
265	infrastructure	VOIP	00:23:f8:8b:88:cd	5	No	WEP	No	0	0
266	infrastructure	macik	00:23:f8:8b:88:cc	5	No	WEP,TKIP	No	0	0
267	infrastructure	www.pranet.cz/111	00:0c:42:18:a6:96	1	No	None	No	0	0

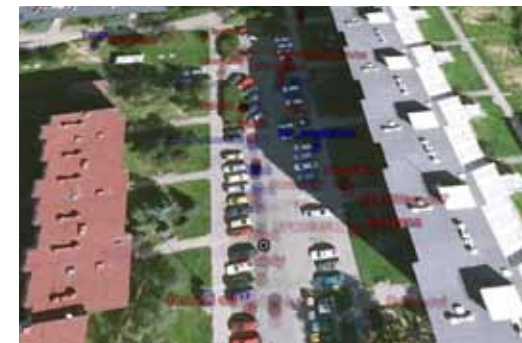
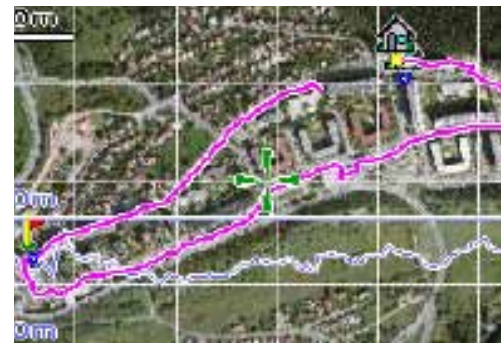

Metabolism

I have been looking for substances which are similar to other famous materials and can be visually substituted. I was looking for subversive versions of well known reality. Playing with idea of second possibility of existence and order. Looking for parallel order and relations where things are not what we are used to. This twisting is starting with expression on face, of one who find in bottle of famous soda, something different.

