



PEUGEOT

NOT 2758

# 308 308GT-

## T91

16 133 620 80



16 133 621 80

98 216 187 80

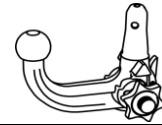

V;R;S Kg ?

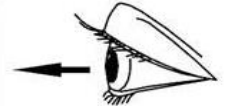

**D** 8,58 kN

TYPE :  
SI 199-SI 200

$$\frac{V \times R}{V + R} \times 0,00981 \leq D \text{ (kN)}$$



e24\*55R-01 0315 - SI 199

e24\*55R-01 0316 - SI 200

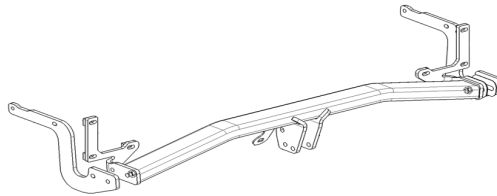
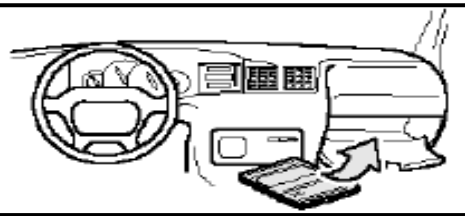

16 133 620 80 : 25 kg

16 133 621 80 : 26 kg

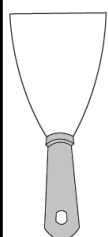
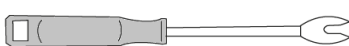
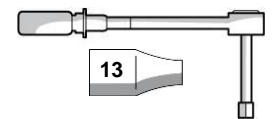
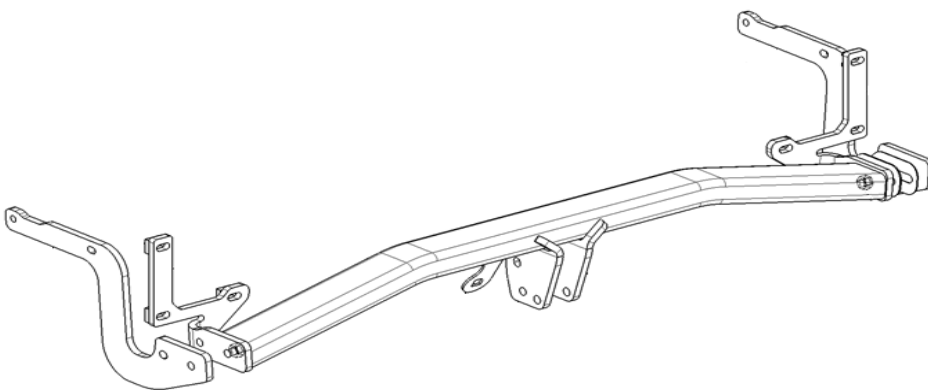

9731.60

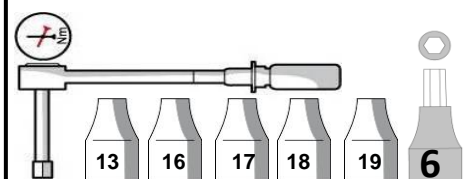
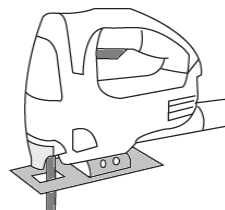

9981.17

9735.CZ

16 133 620 80 - 16 133 621 80 - 98 216 187 80









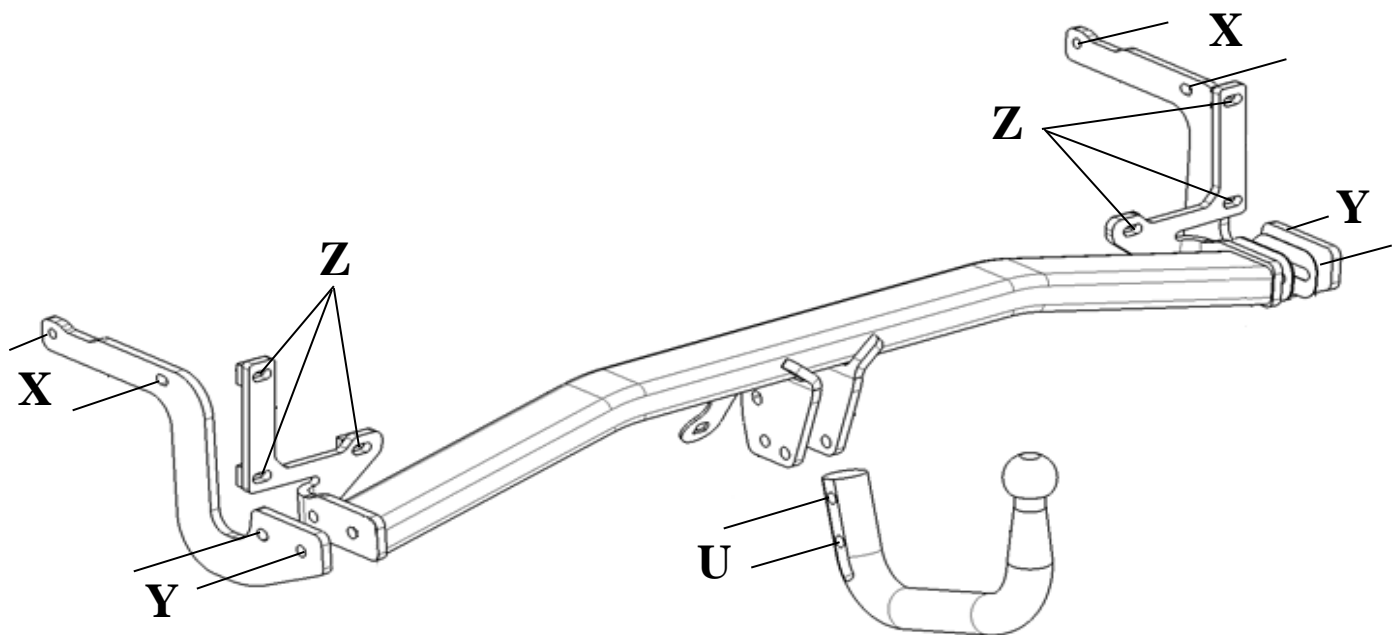

Indice C (26/04/2017)

16/09/2015

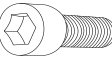
1 / 22









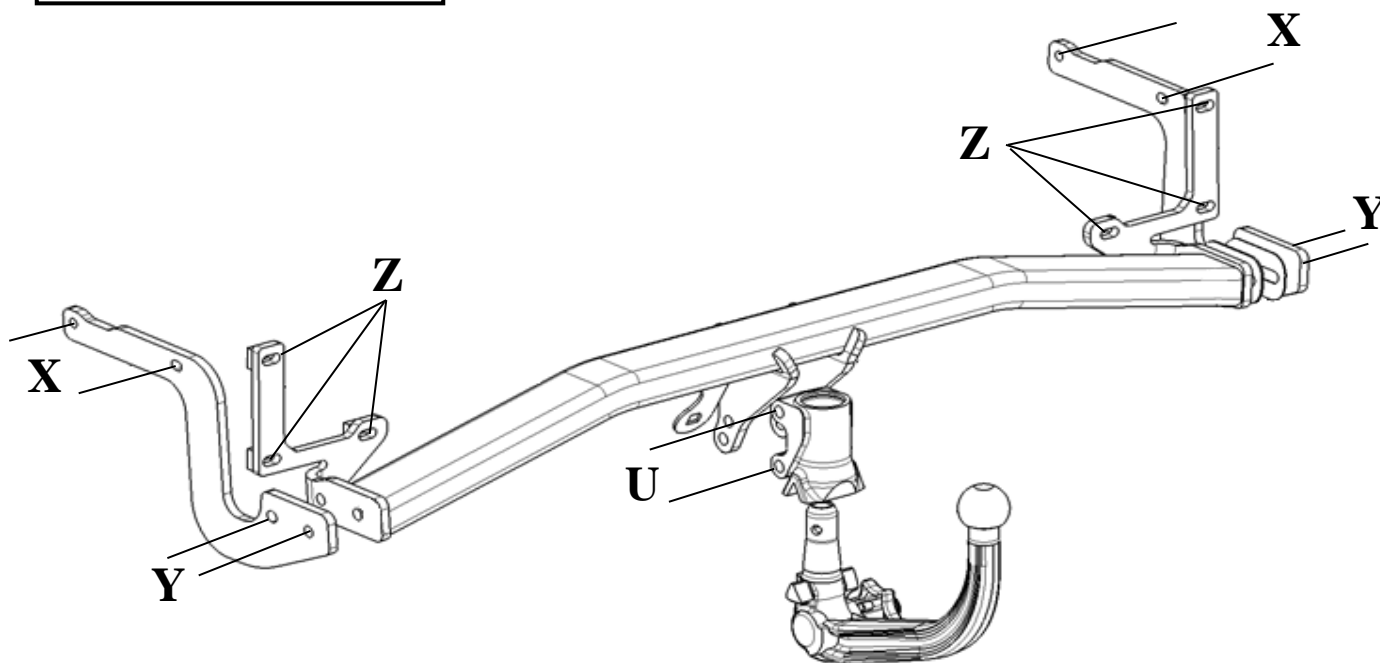

**16 133 620 80**

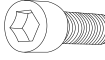

<b>X</b>		M 10 - cl8 - 51 Nm	x 4
<b>Y</b>		HM 12x40 - Cl 10.9 - 80 Nm	x 4
		M 12 - cl 10	x 2
		CS 12 / 24	x 4
<b>Z</b>		CHCM 8x50 Cl 12.9 - 31 Nm	x 6
		M 8 Cl 10	x 6
		CS 8 / 18	x 6
		20 / 8 x 7,5	x 6
<b>U</b>		HM 12x75 - Cl 10.9 - 116 Nm	x 2
		M12 Cl 10	x 2

**16 133 621 80**



<b>X</b>		M 10 Cl 8 - 51 Nm	x 4
		HM 12x40 - Cl10.9 - 80 Nm	x 4
<b>Y</b>		M 12 Cl 10	x 2
		CS 12 / 24	x 4
<b>Z</b>		CHCM 8x50 Cl 12.9 - 31 Nm	x 6
		M 8 Cl 10	x 6
		CS 8 / 18	x 6
		20 / 8 x 7,5	x 6
<b>U</b>		HM 12x100 - Cl 10.9 - 116 Nm	x 2
		CS 12 / 24	x 2
		M12 Cl 10	x 2

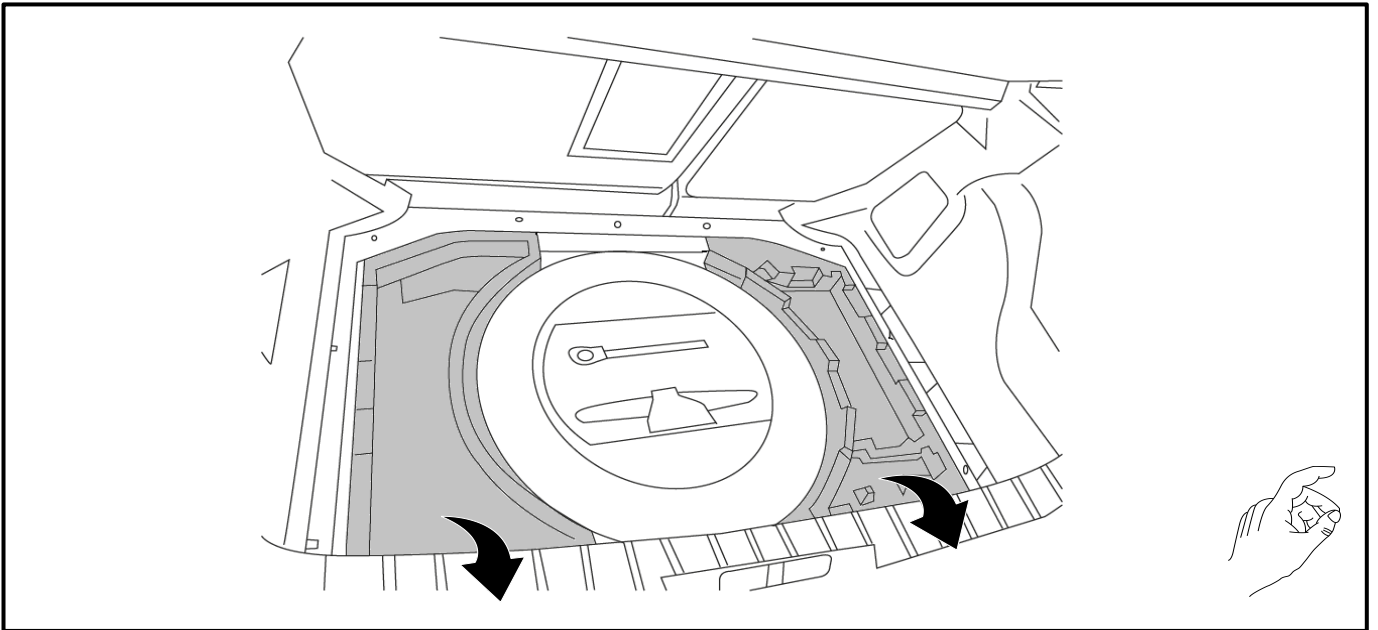
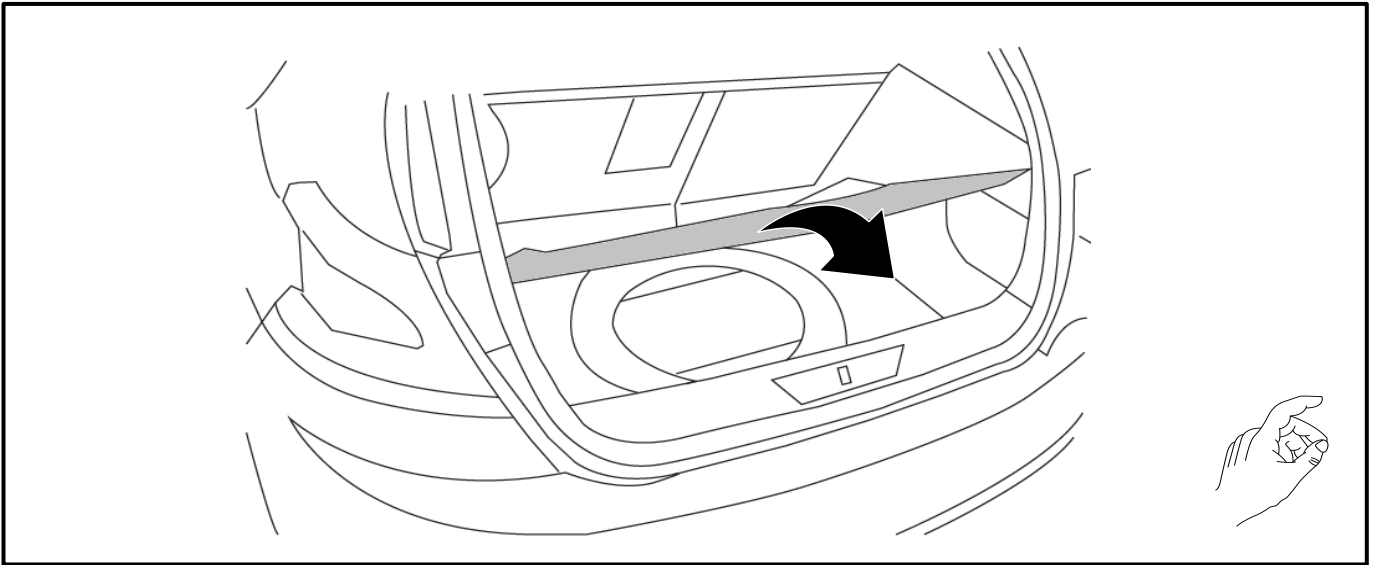
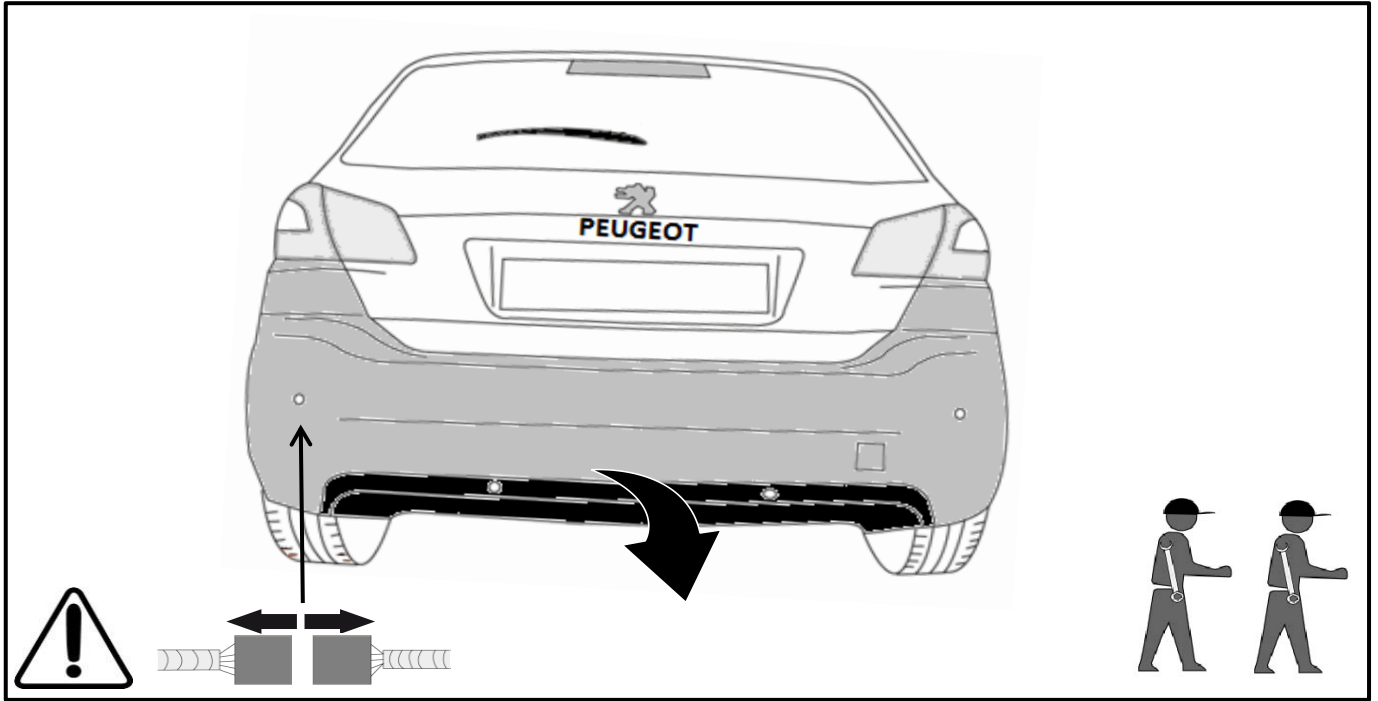

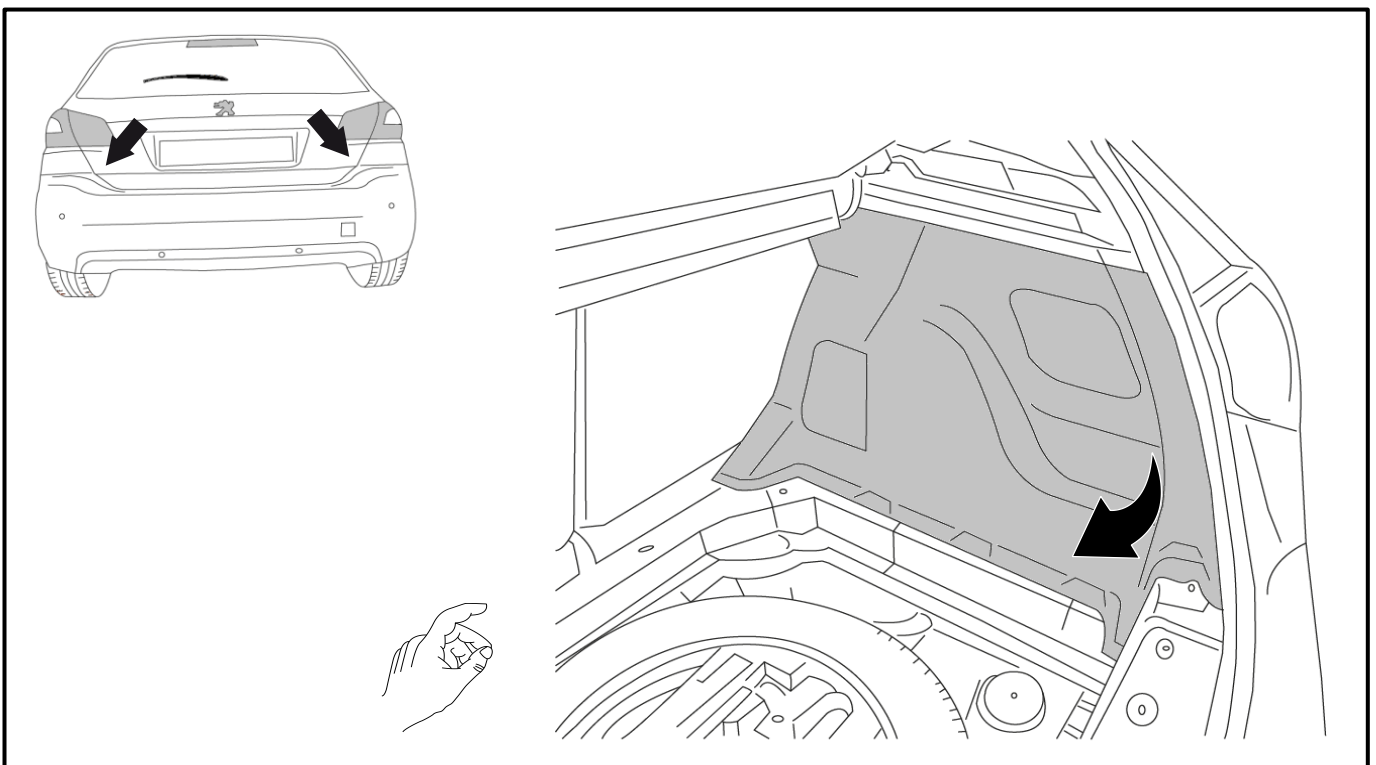
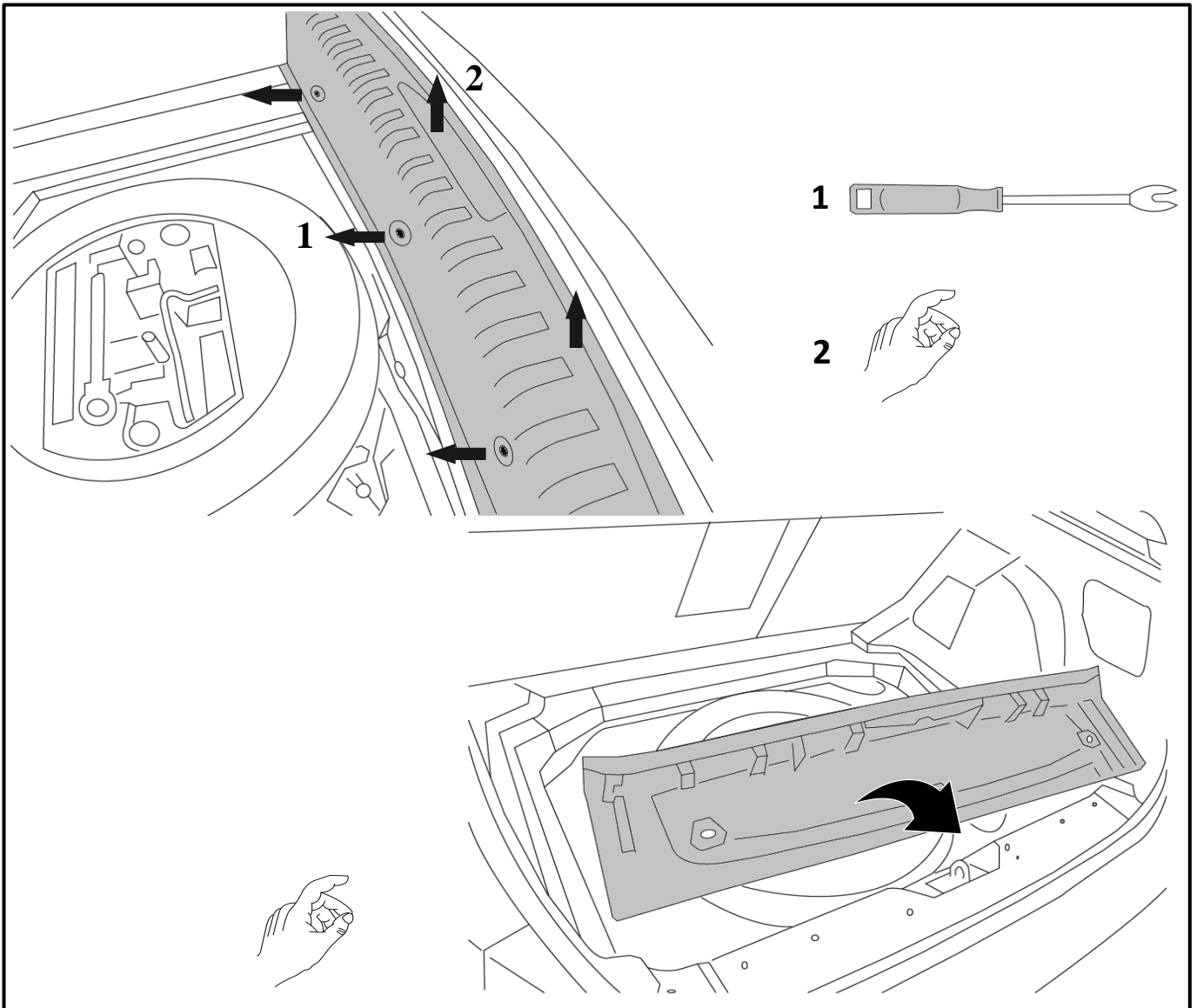

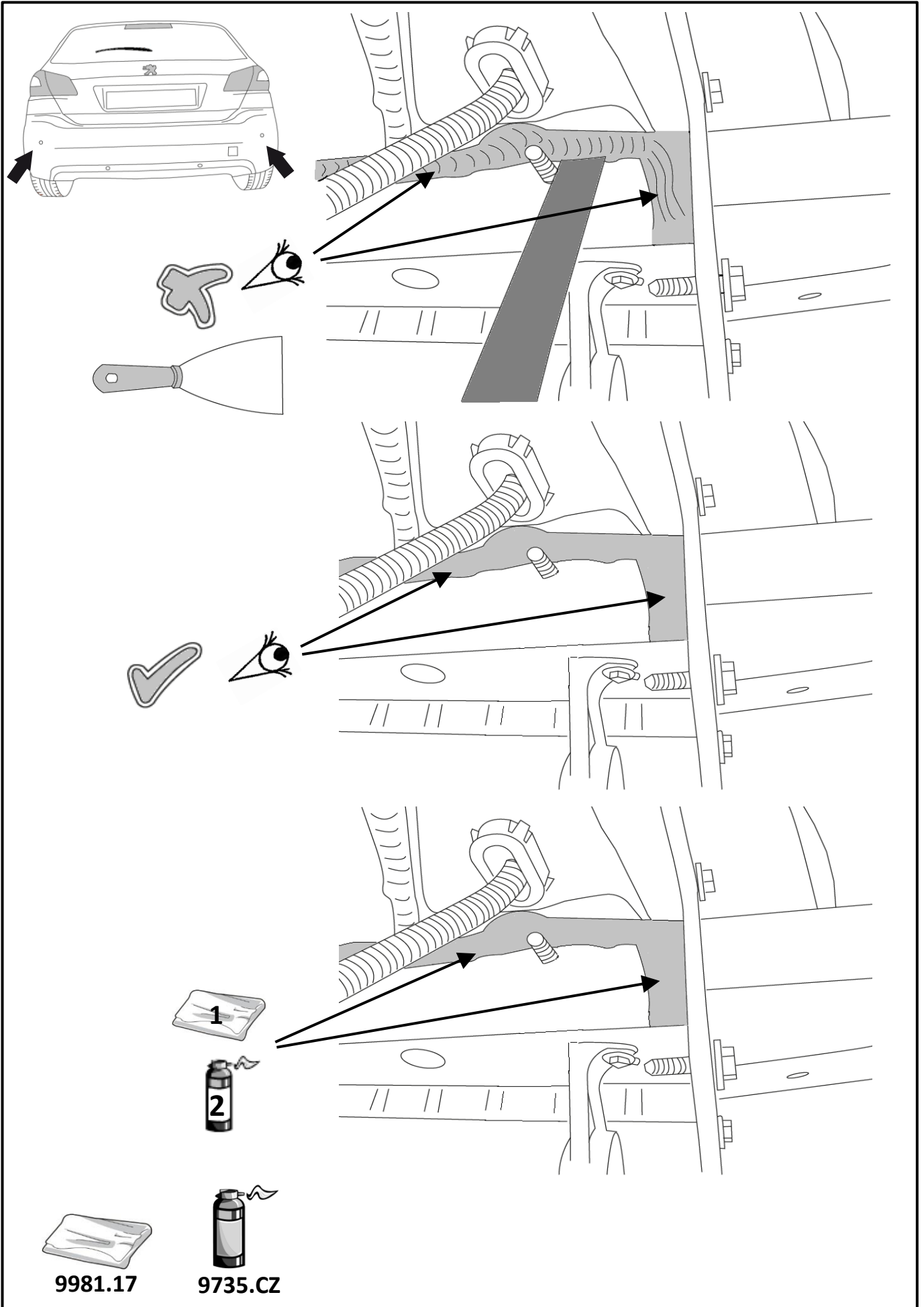

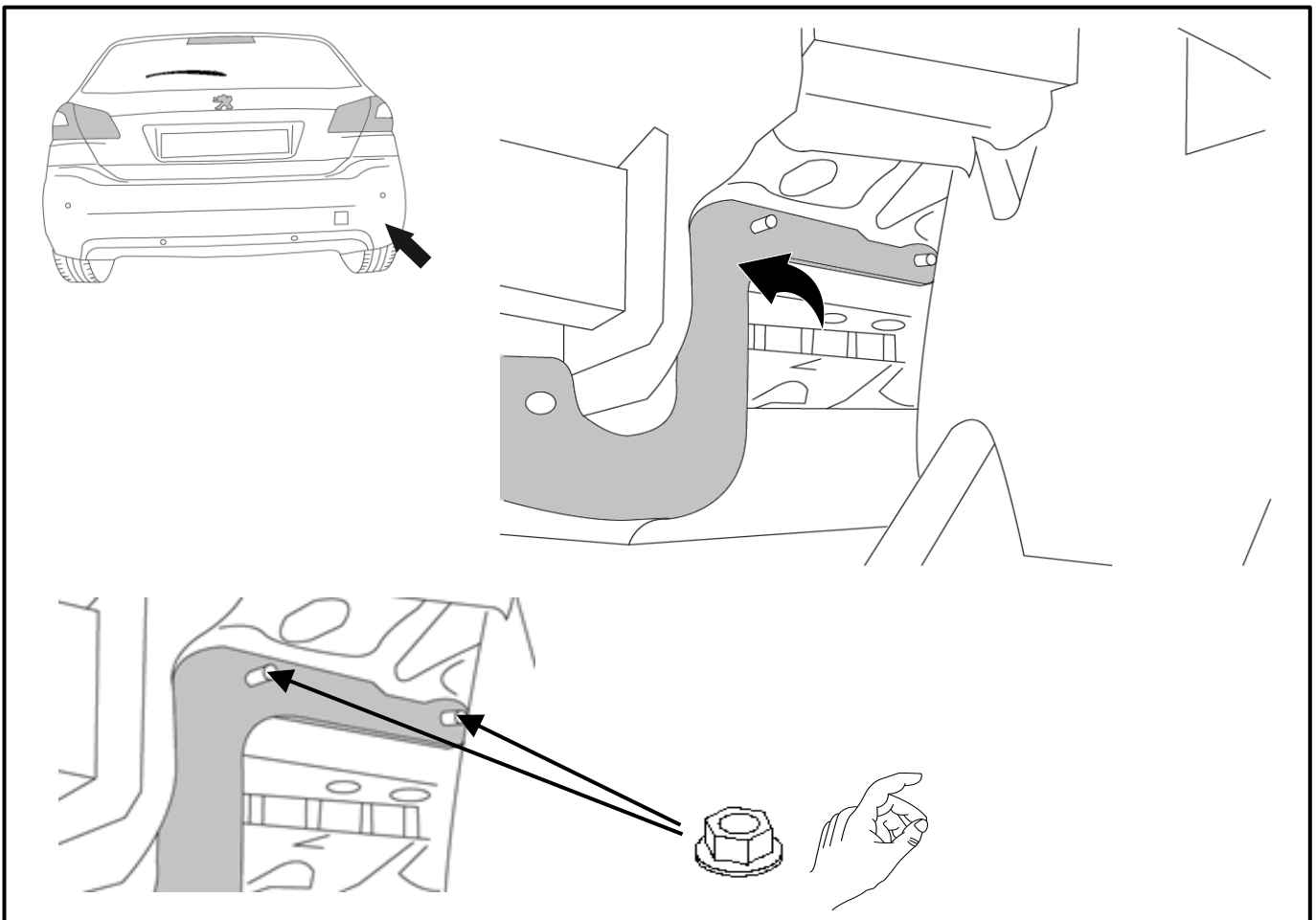
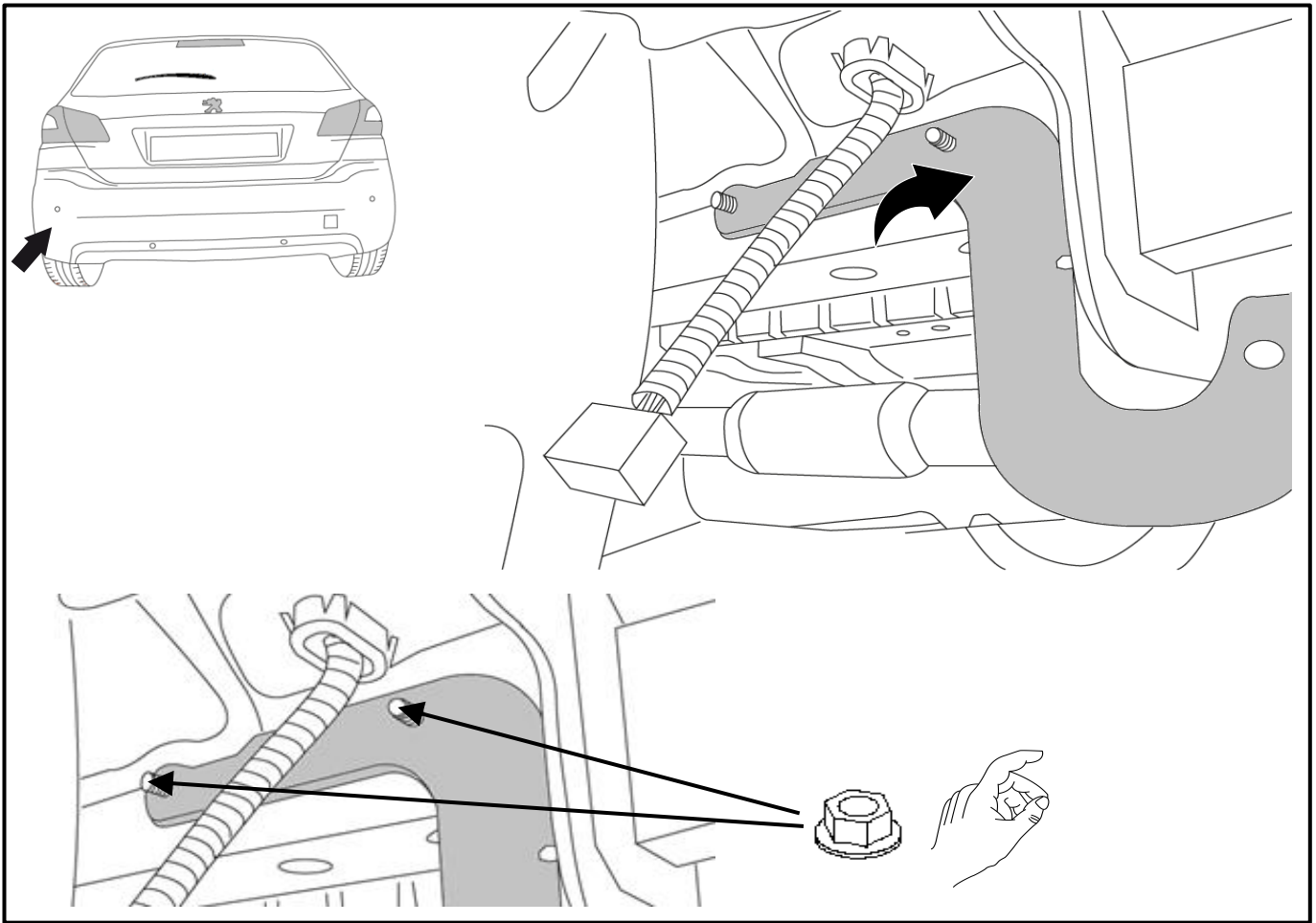



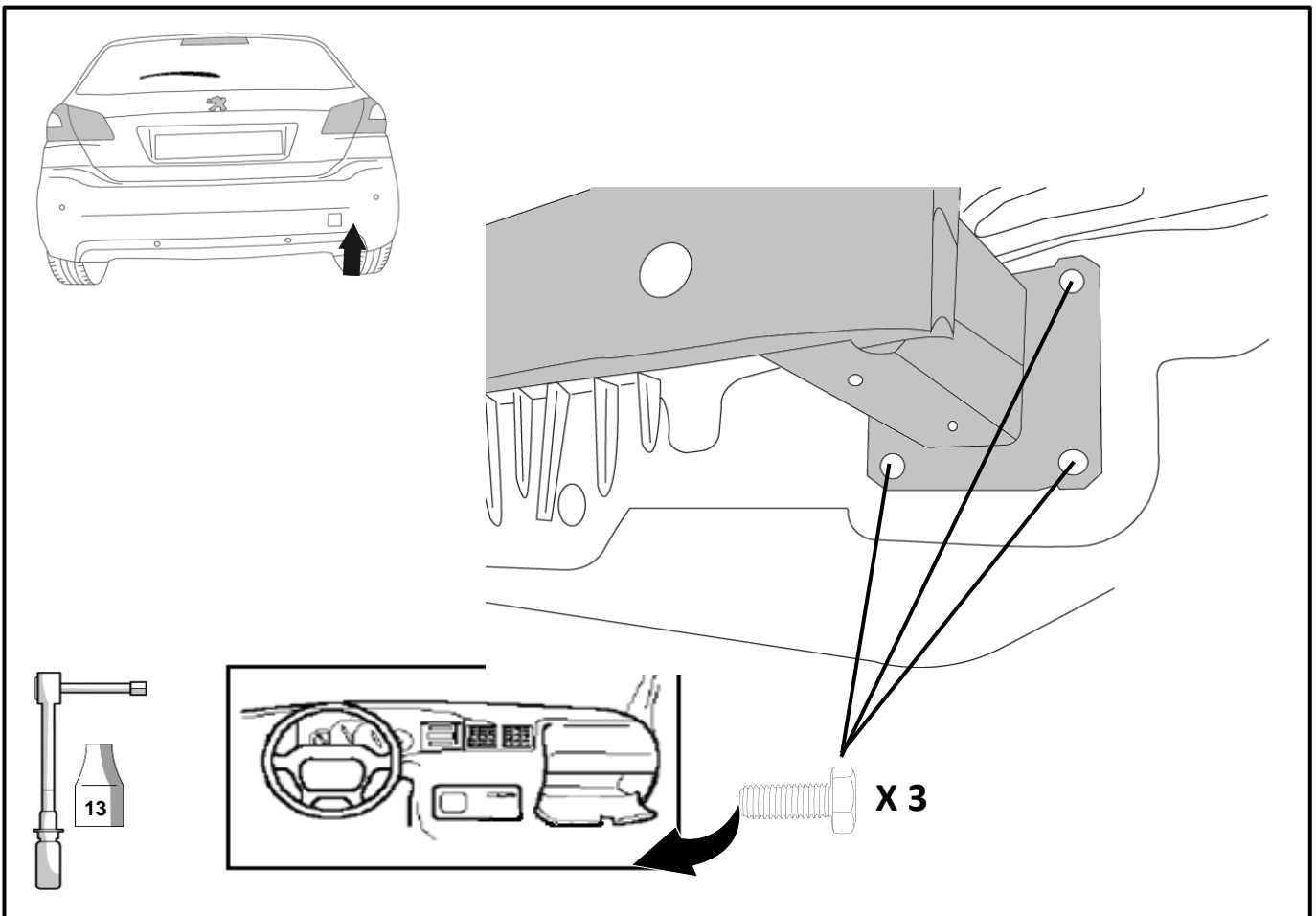
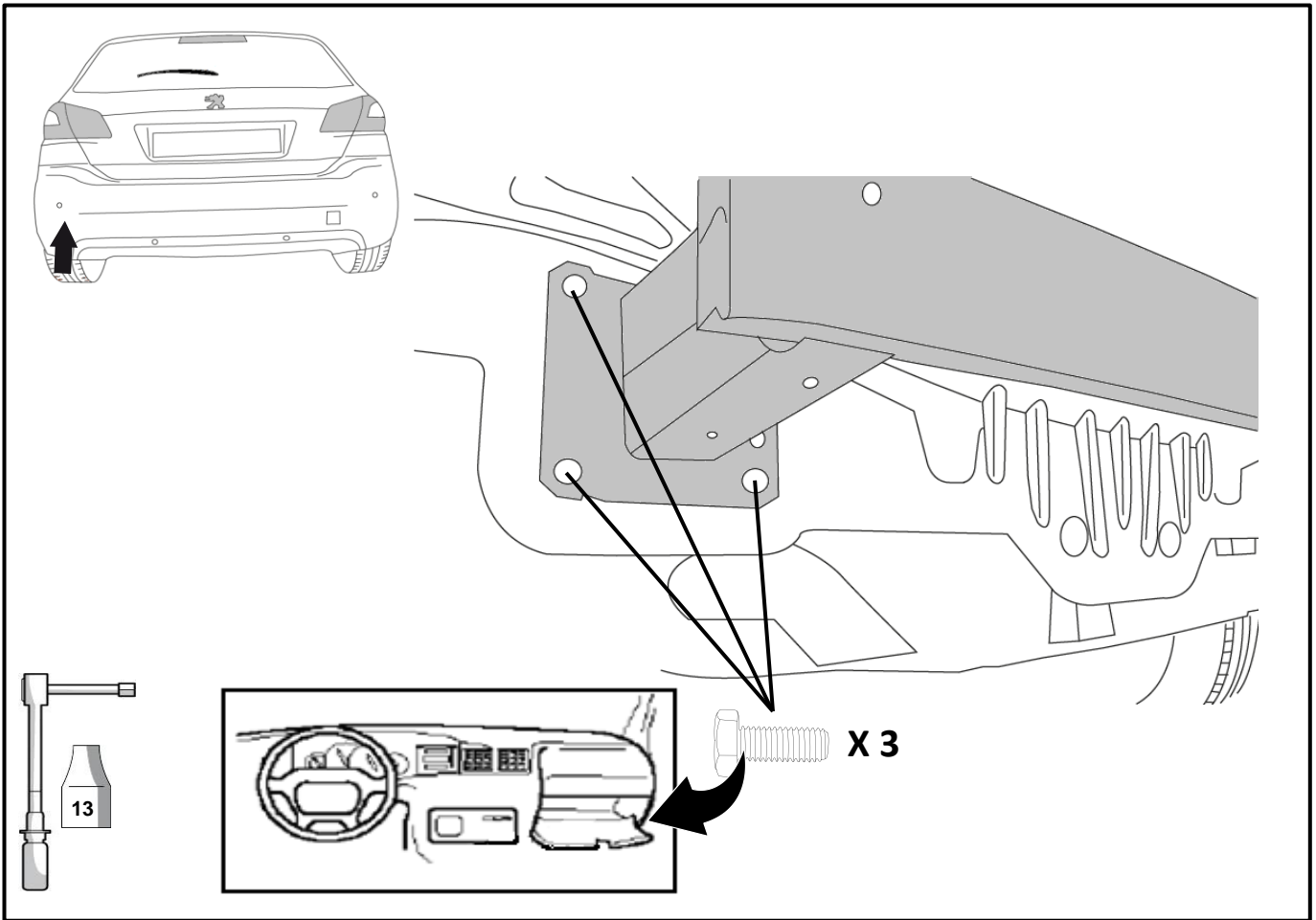



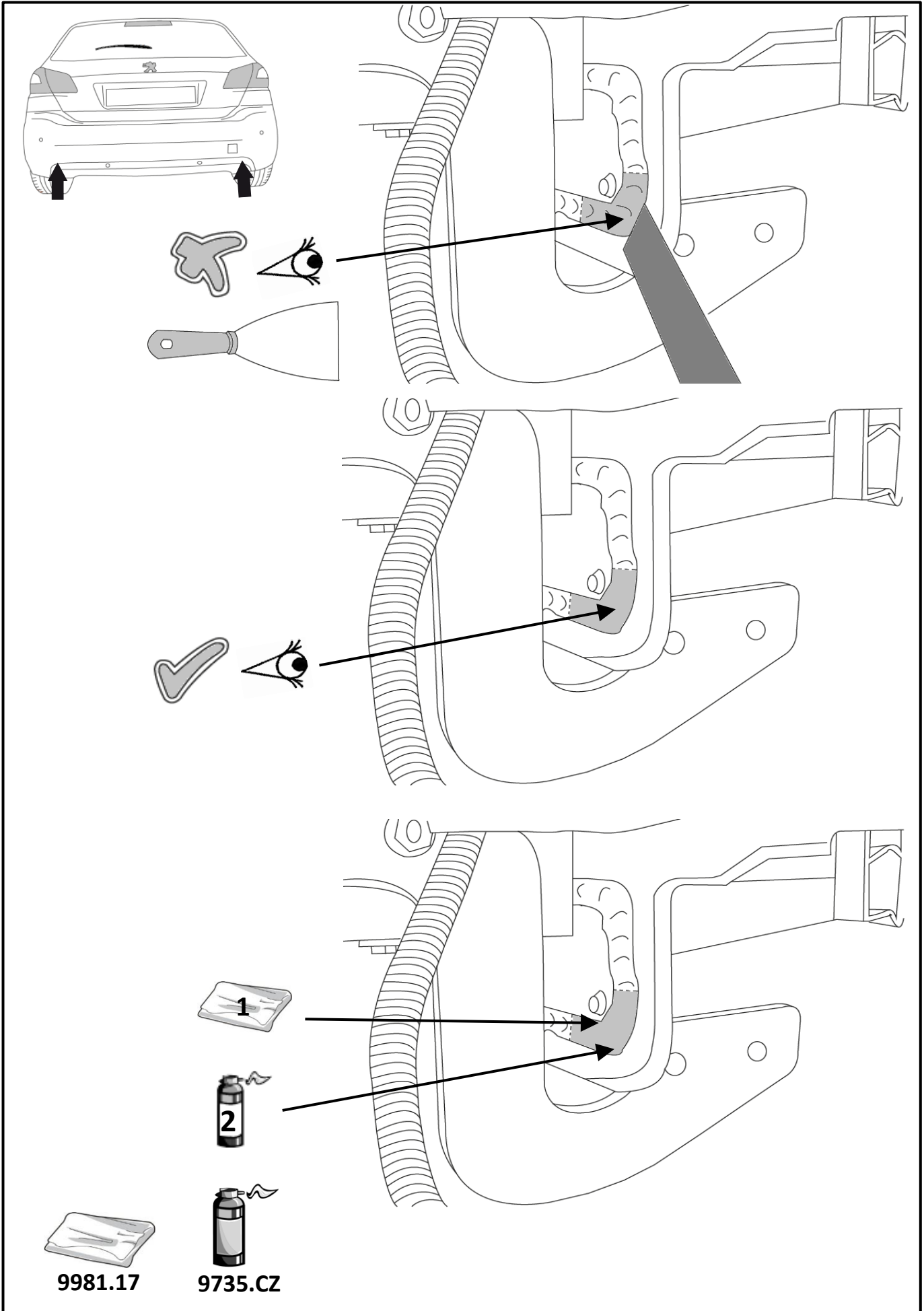

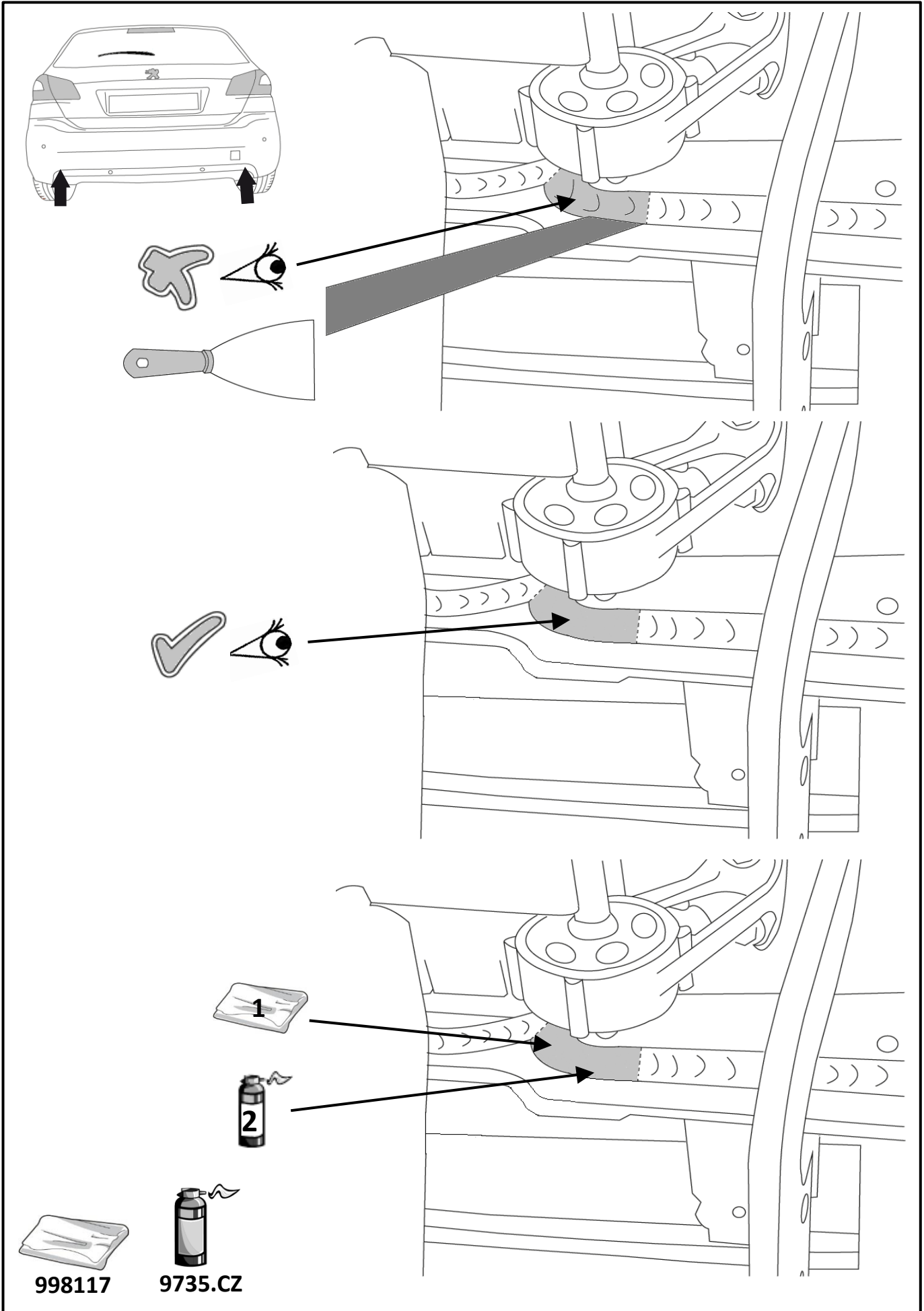

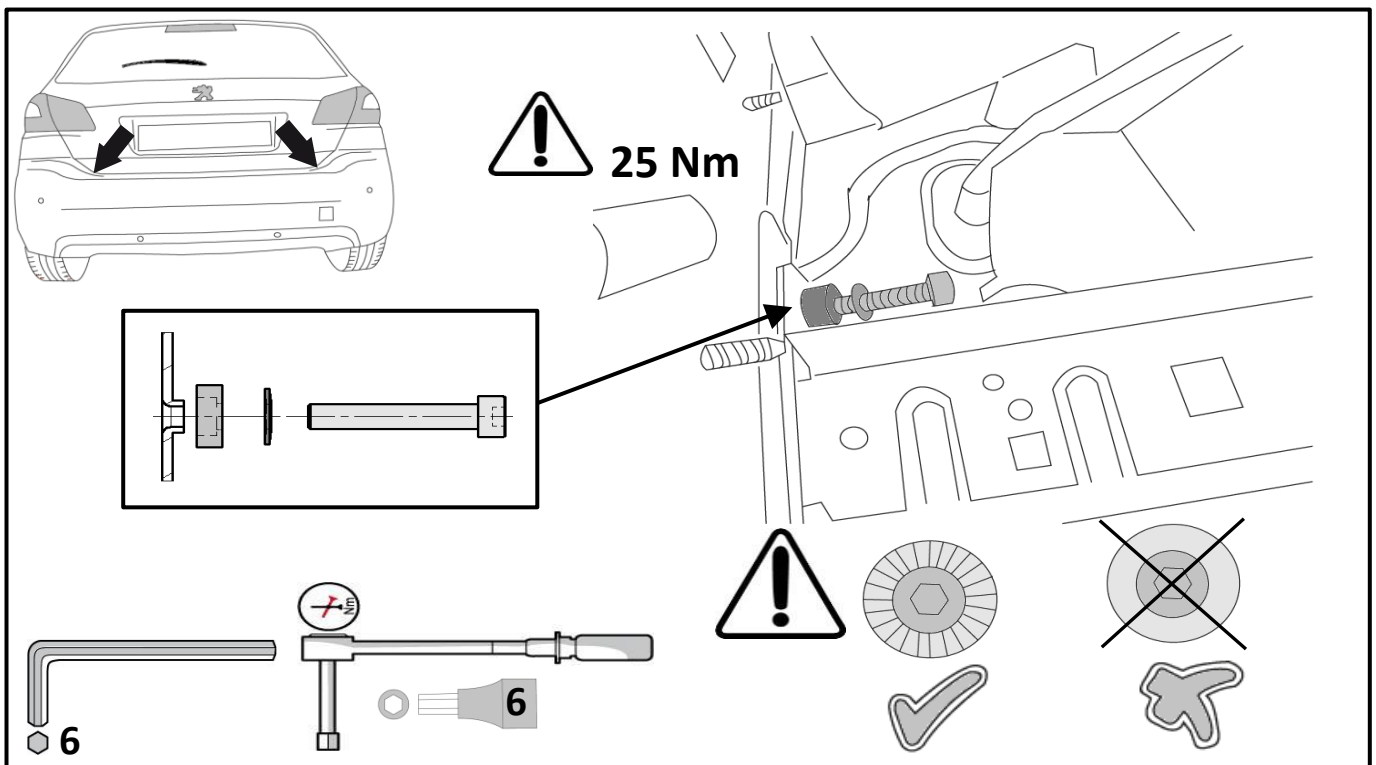
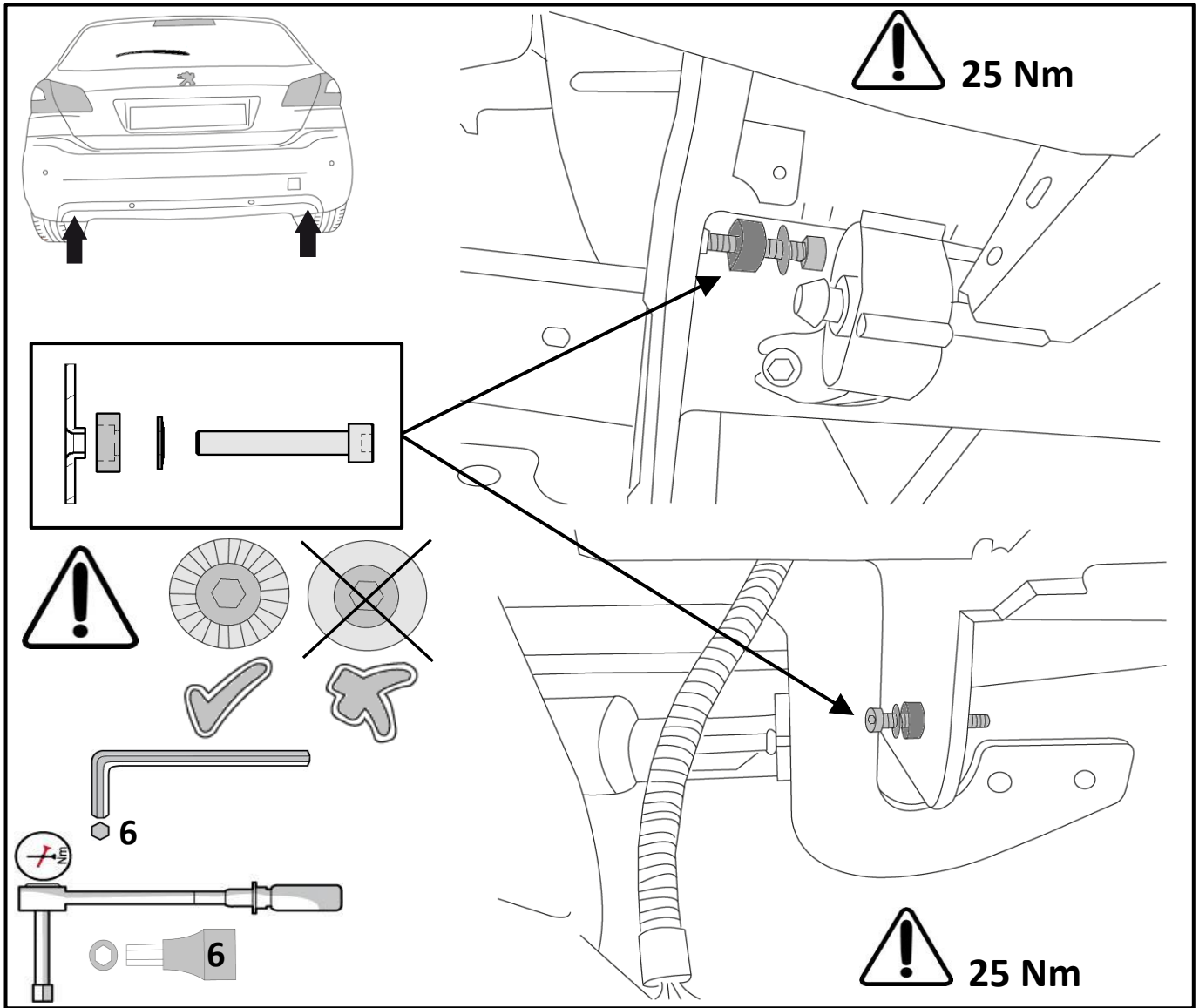

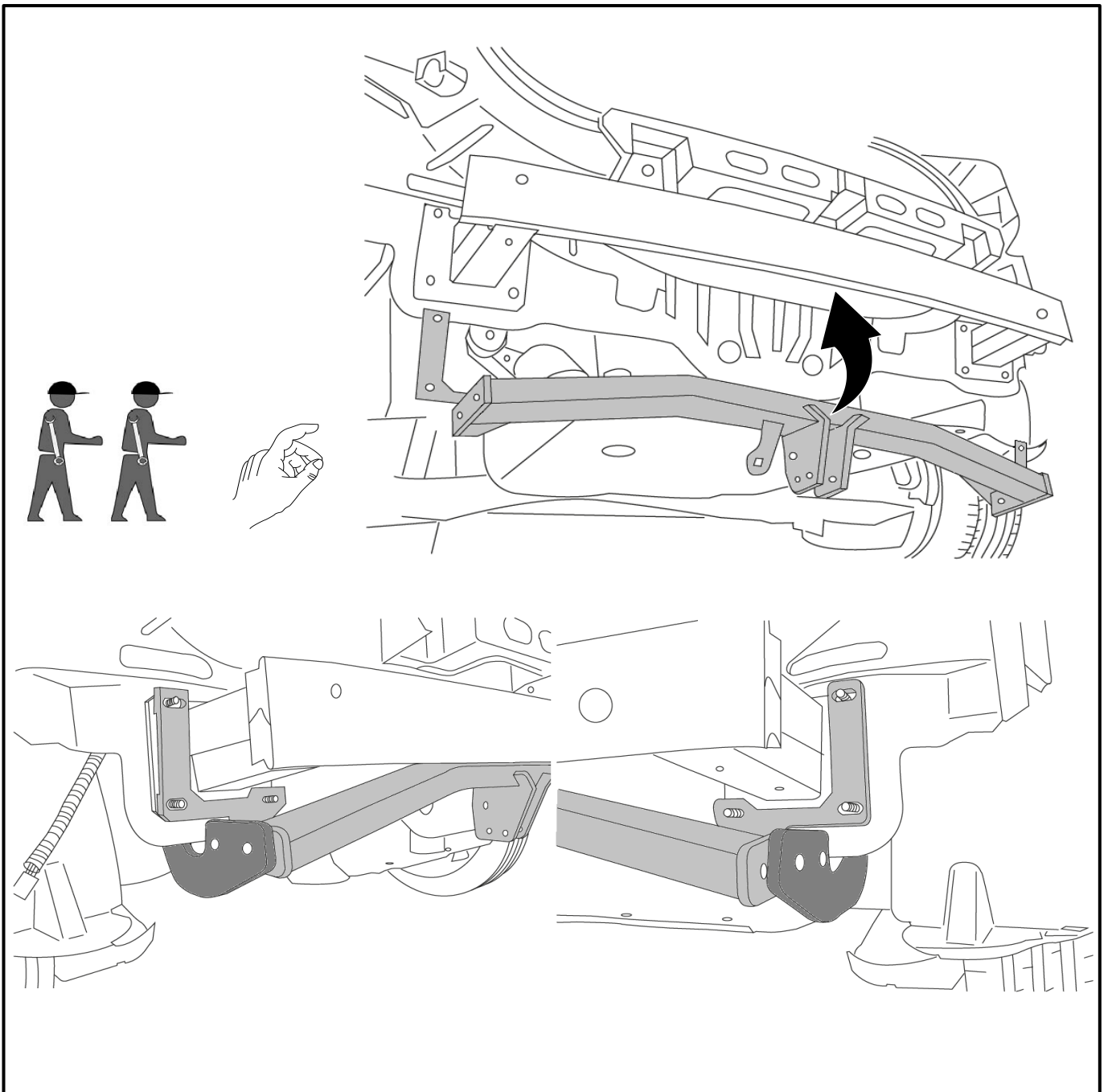
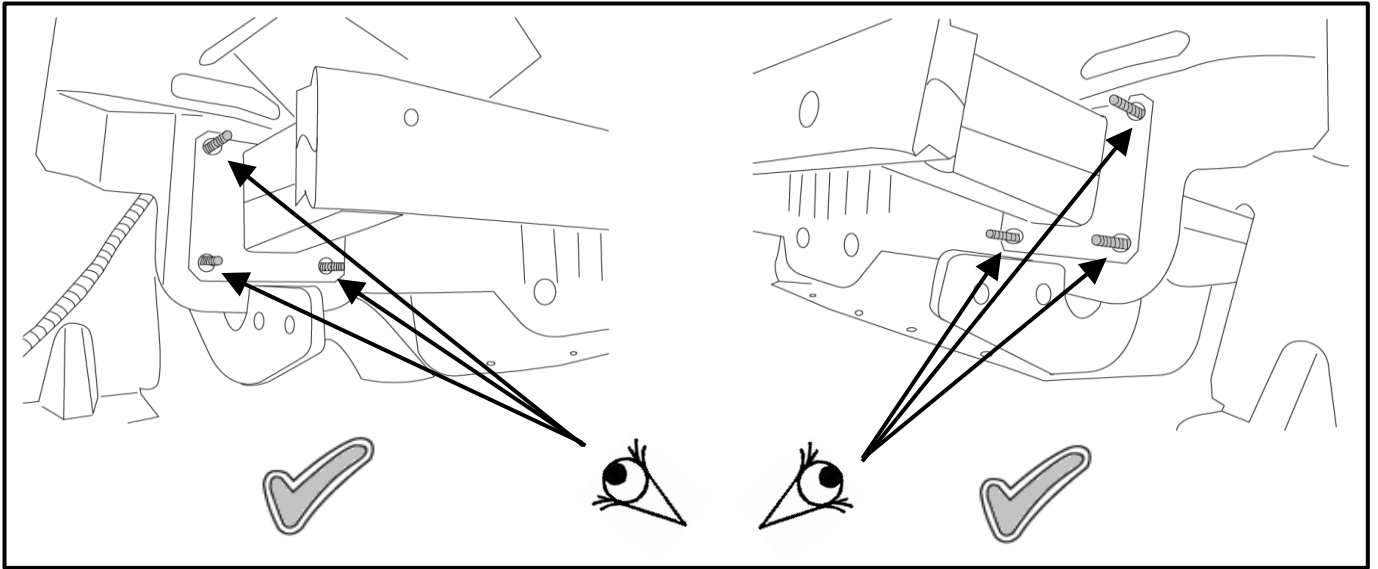

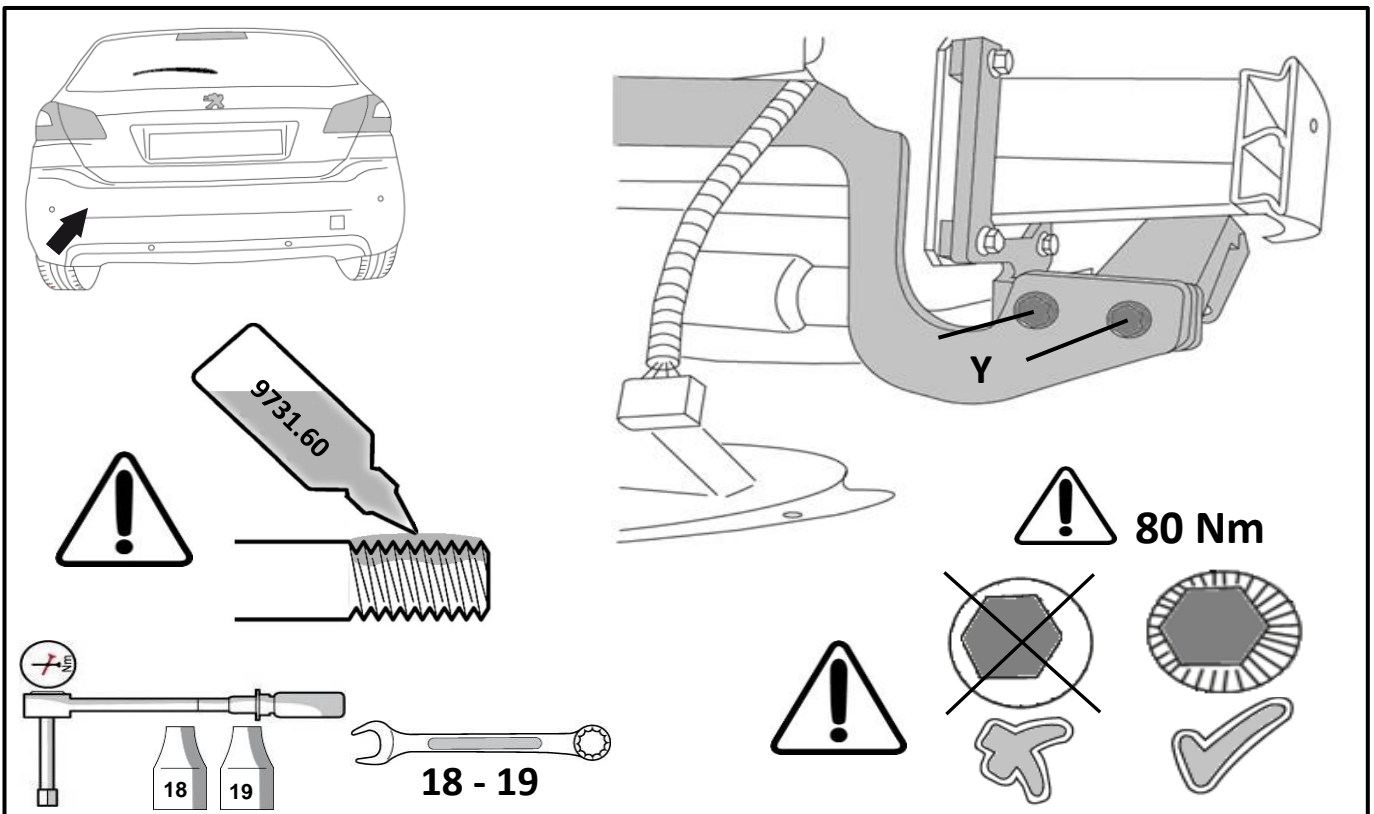
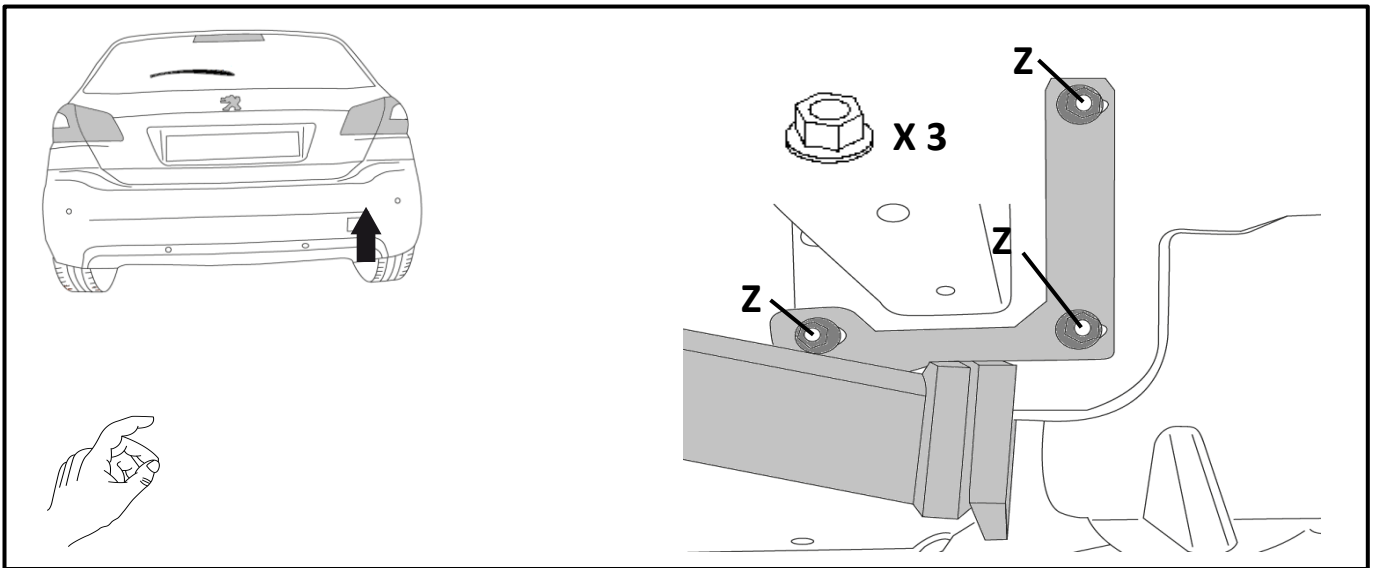
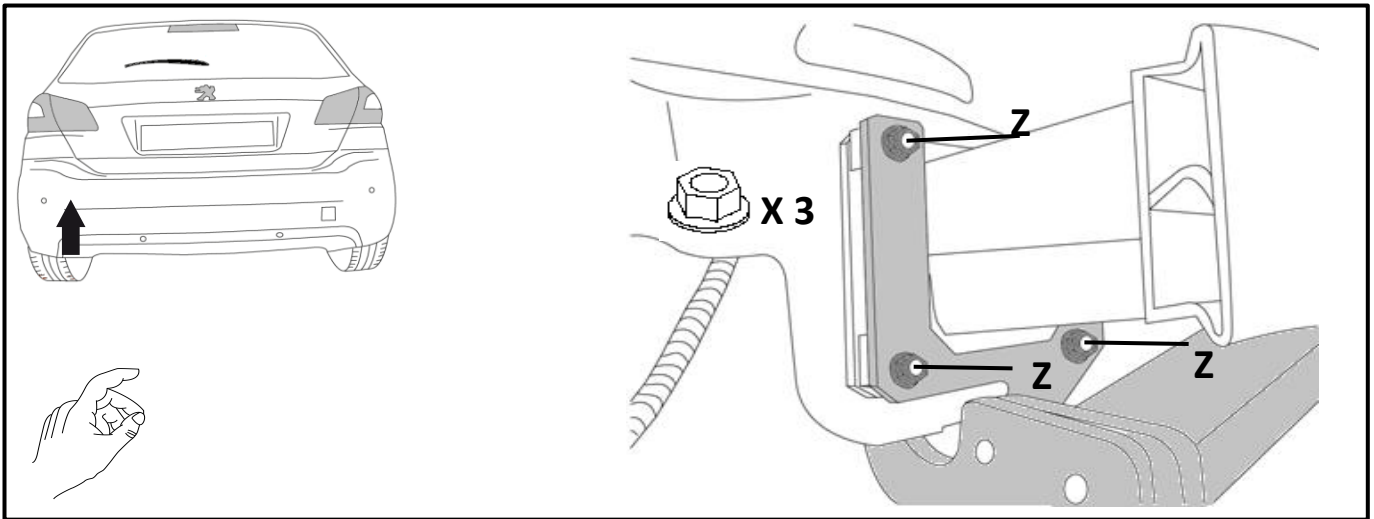



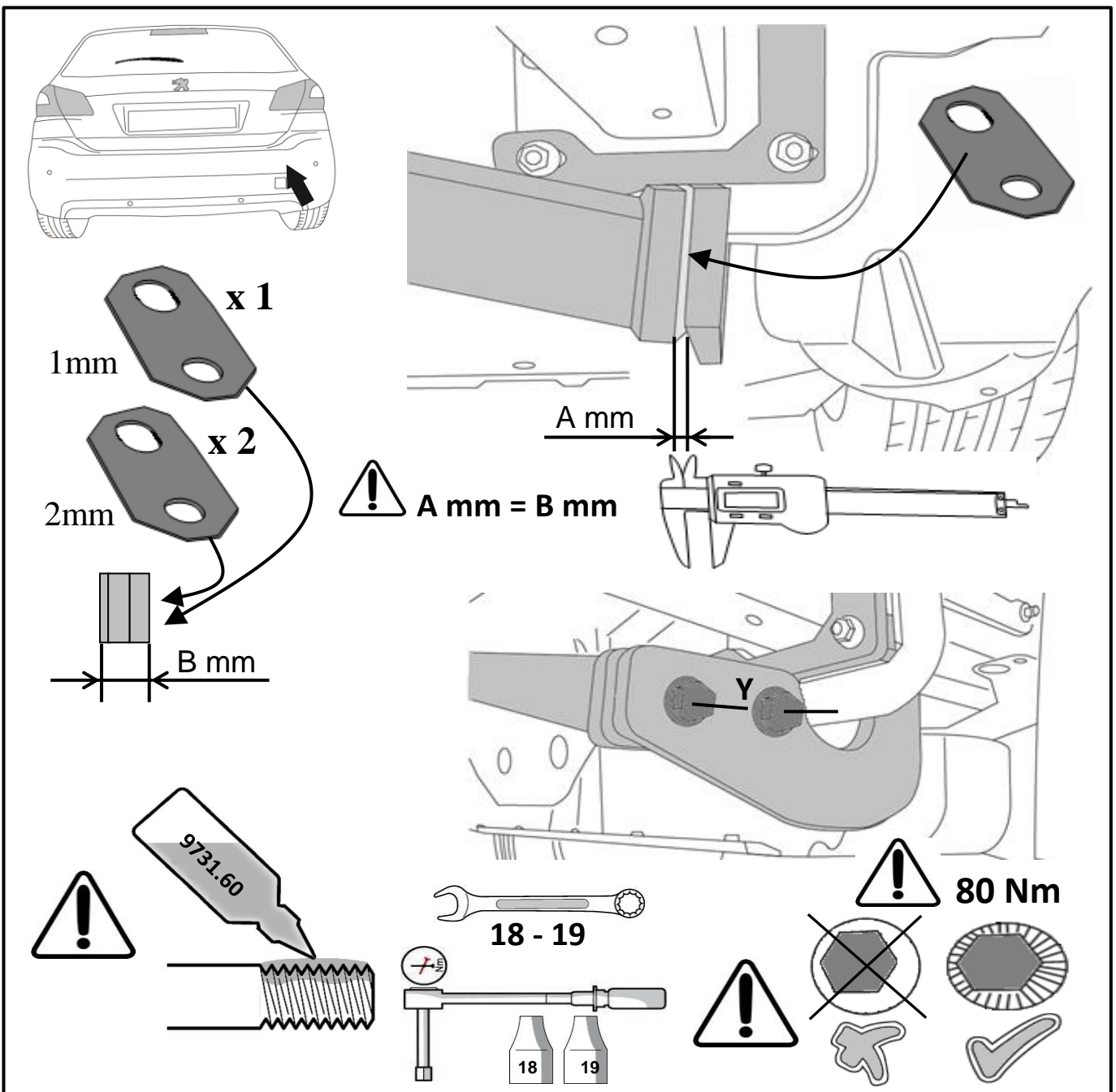
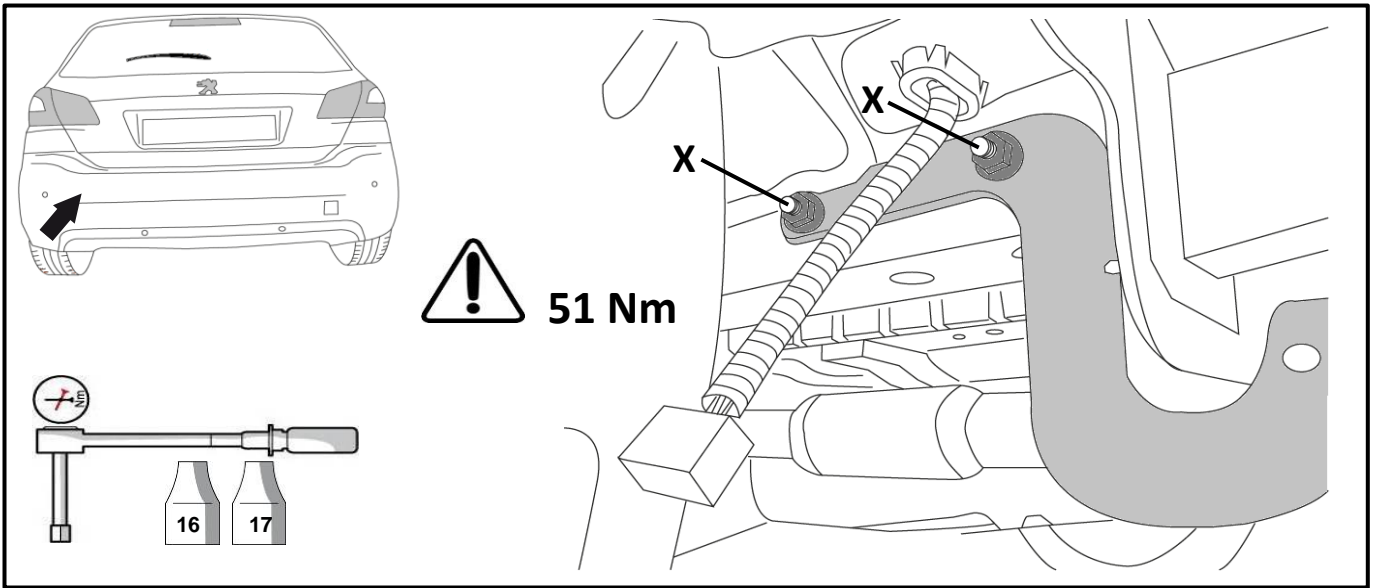

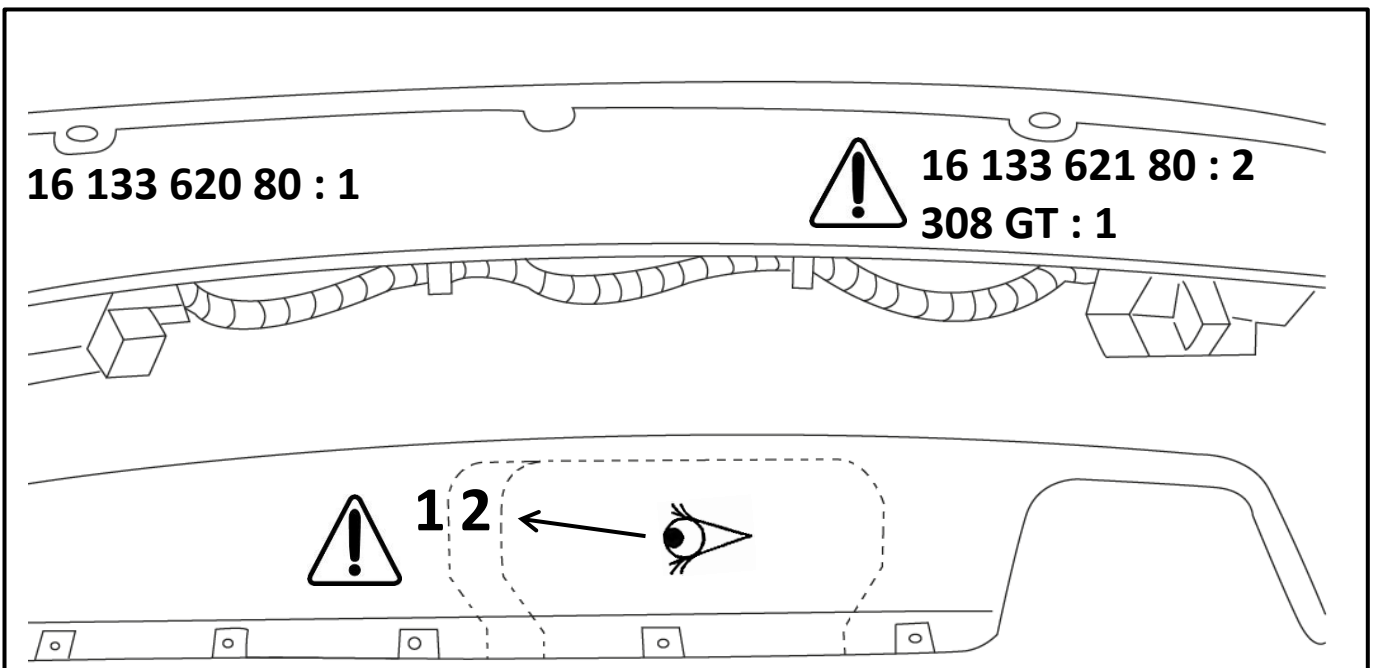
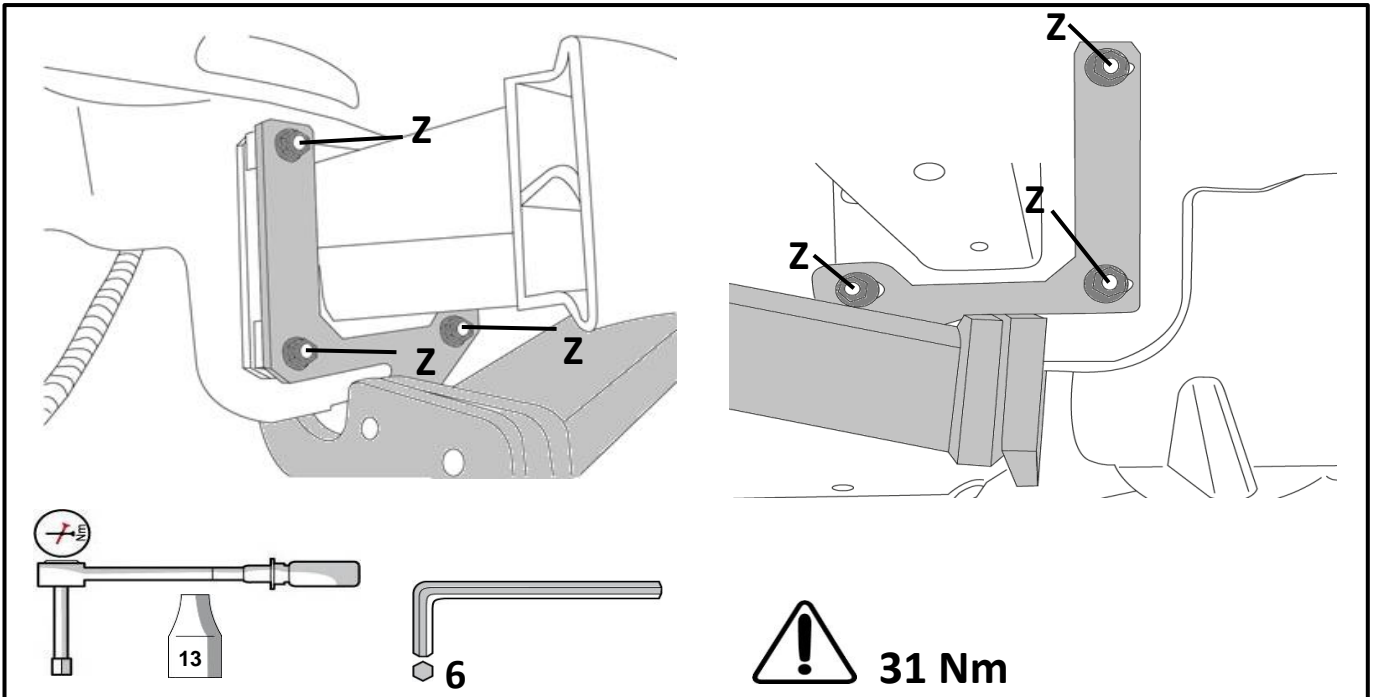
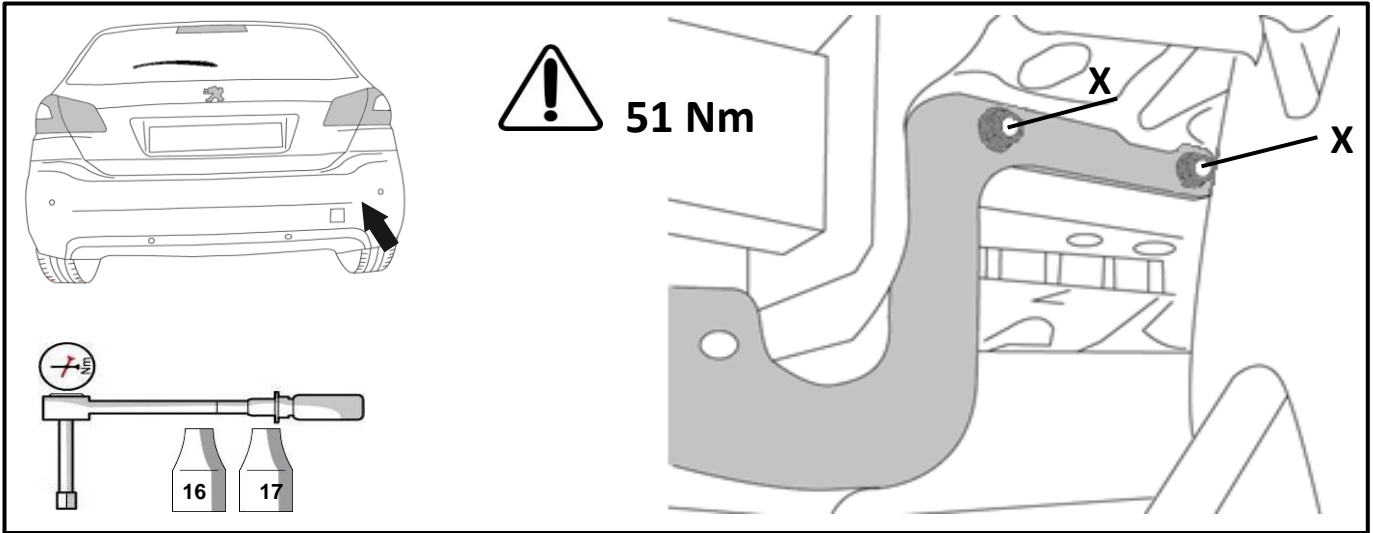



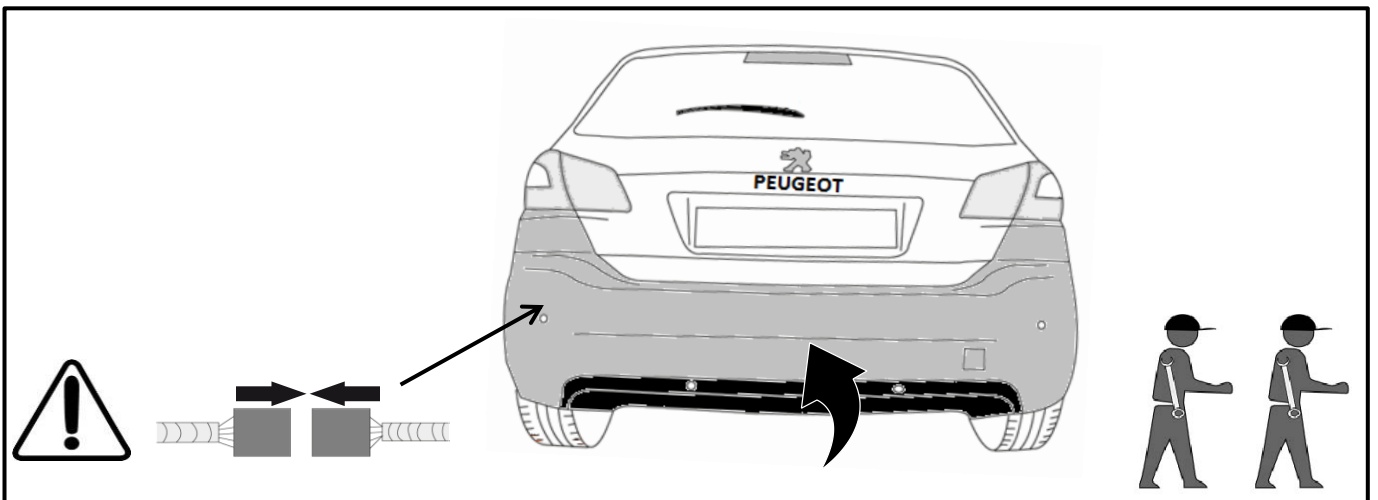
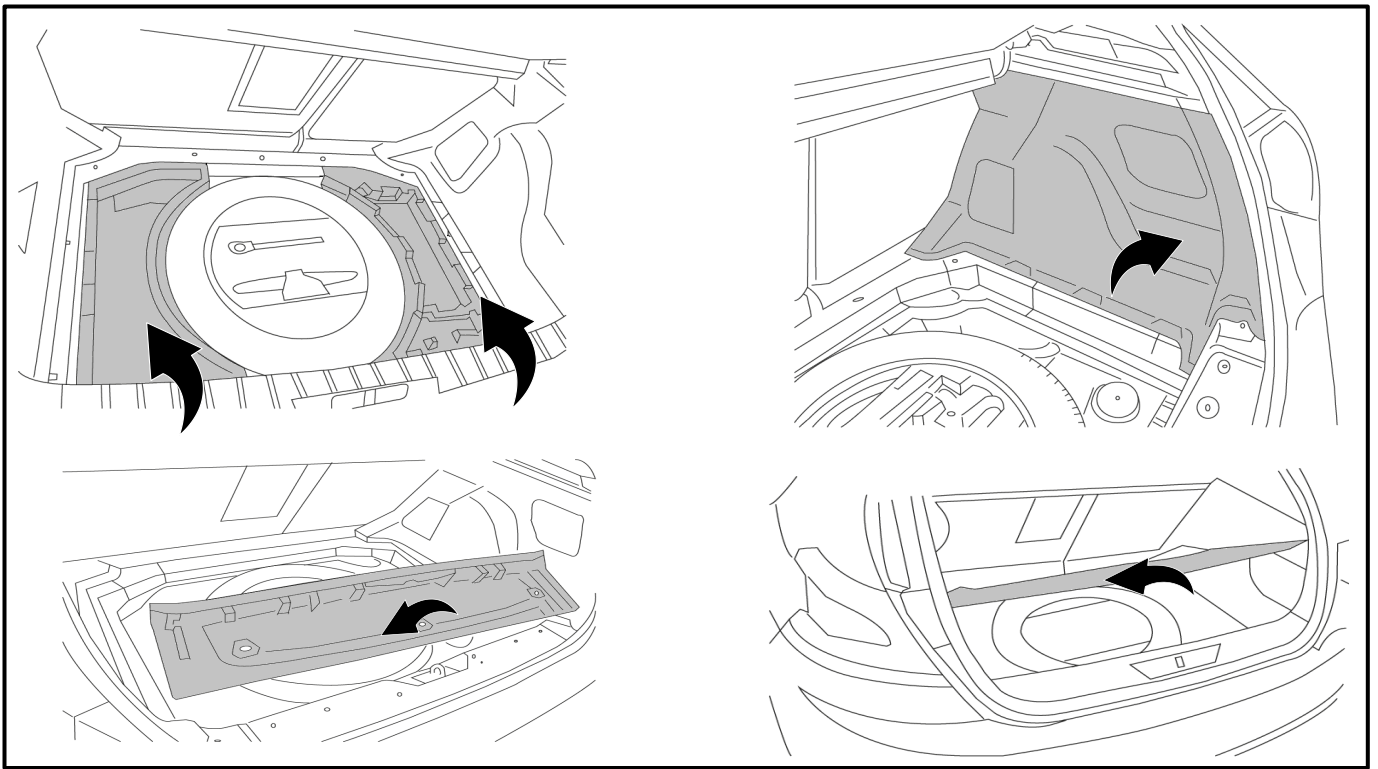
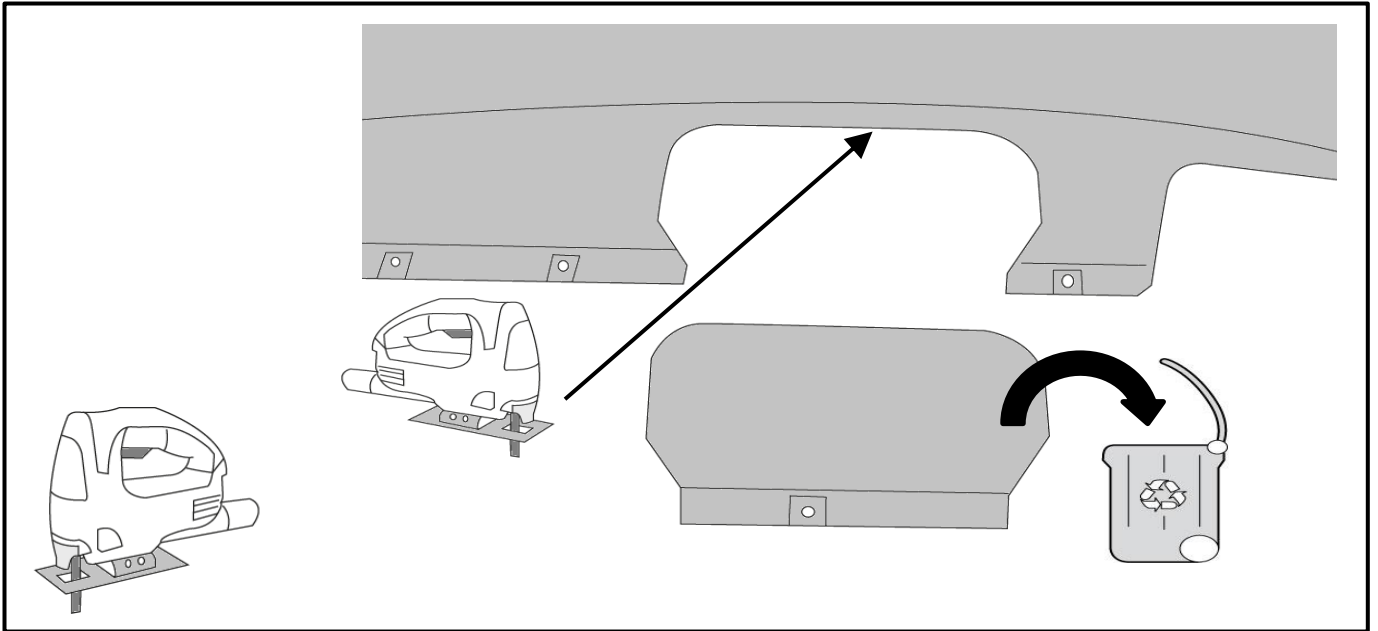

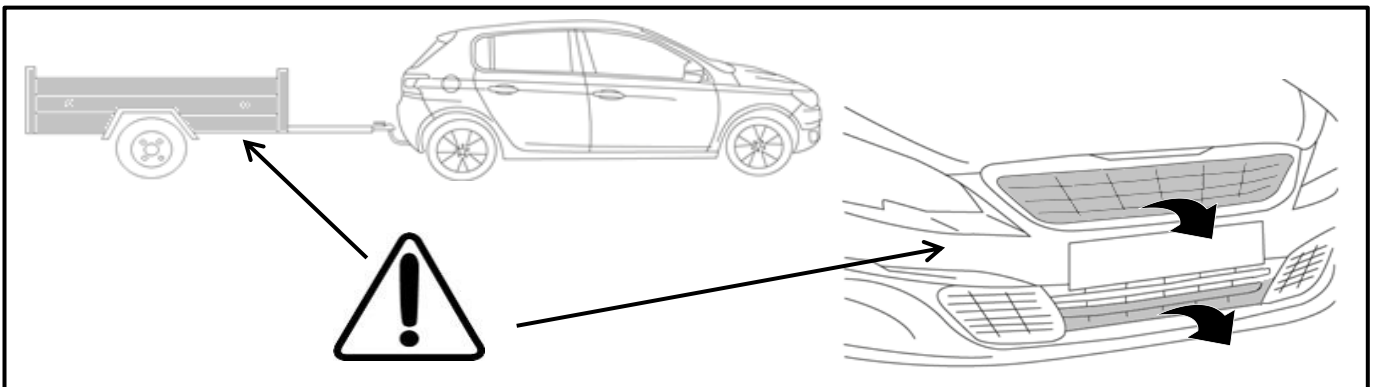
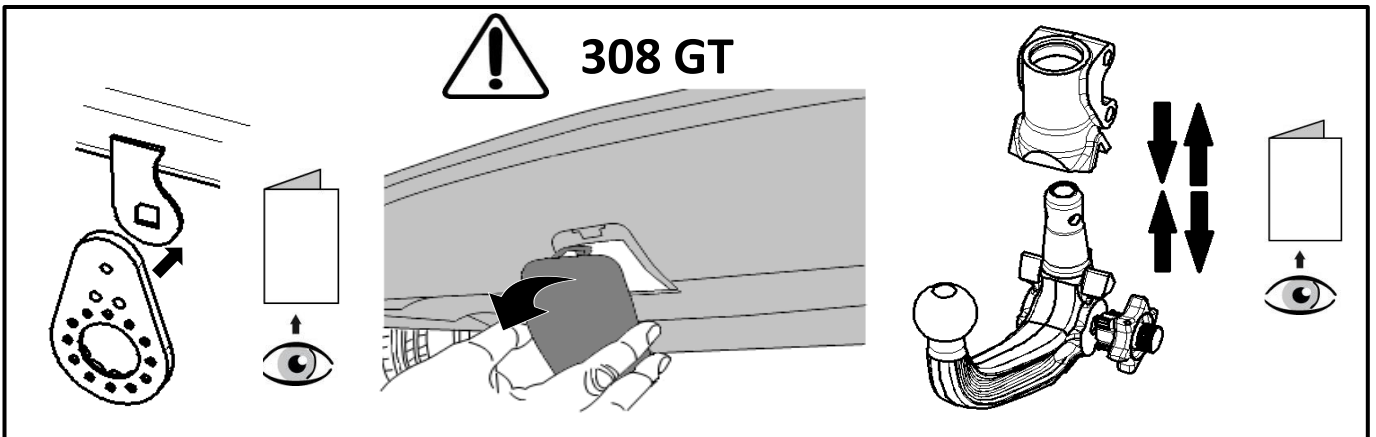
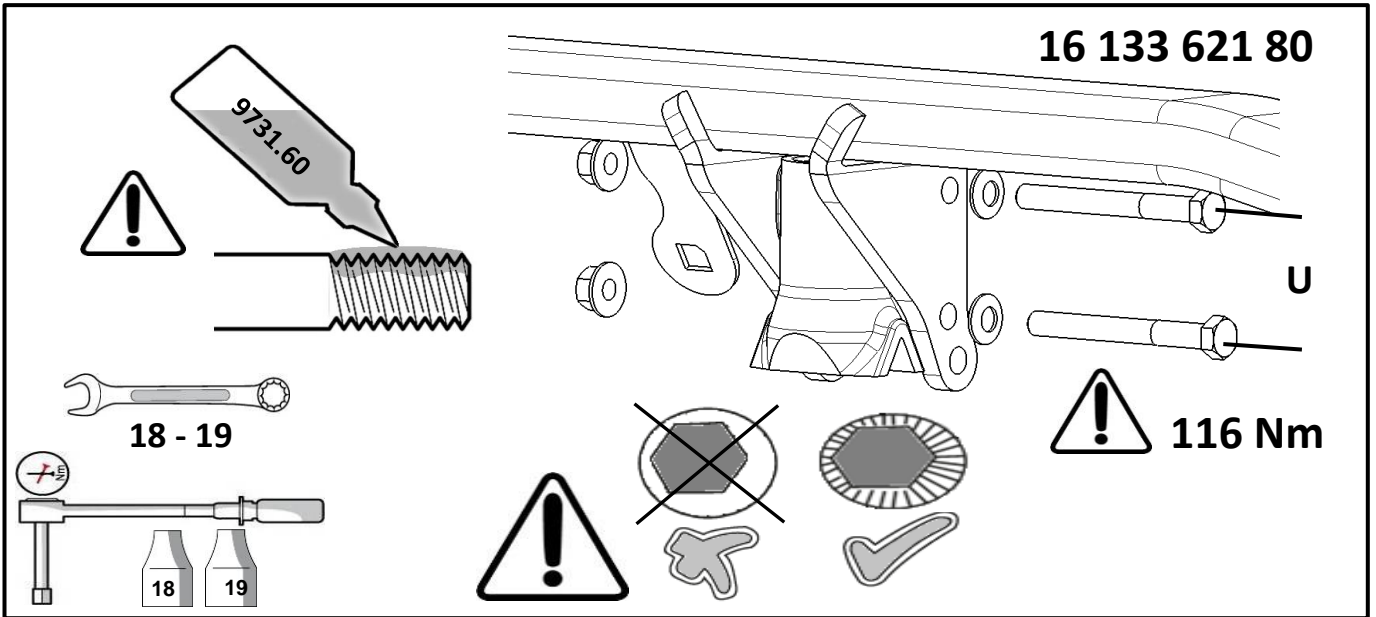
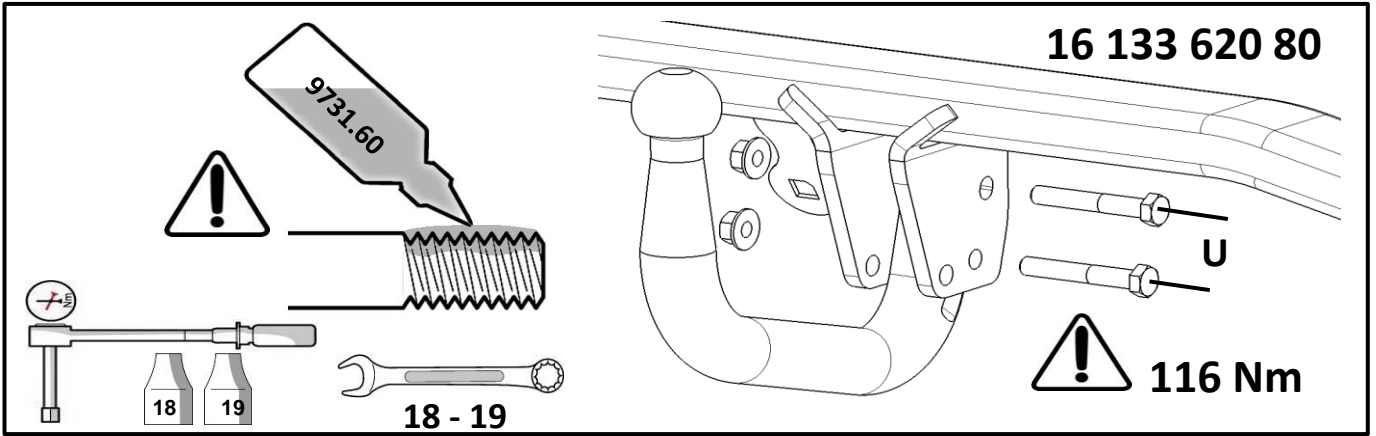

Dispositivo di traino tipo : **16 133 620 80**  
Per autoveicolo : **PEUGEOT 308**  
Tipo funzionale : **L\*\*\*\*\*-C\*\*\*\*\***

Classe e tipo di attacco : **A50-X**  
Omologazione : **e24\*R55 01 0315**  
Valore D : **8,58 kN**  
Carico verticale max. S : **75 kg**

Larghezza rimorchiabile per Caravan e T.A.T.S. : 2,55m vedere CARTA di CIRCOLAZIONE VEICOLO (motrice) + 70cm = ...arrotondare ai 5cm superiore (vedi D.M.28/05/85)

Massa rimorchiabile : vedi carta di circolazione dell'autoveicolo

**Per verificare l'idoneità del dispositivo di traino omologato a norma CEE R55, all'installazione sulla vettura su cui si intende procedere al montaggio, compilare la seguente formula (se necessario declassare la massa rimorchiabile) :**

$$D = \frac{T \times C}{T + C} \times 0,00981 < 8,58 \text{ kN}$$

dove : T = Massa Complessiva Max. della motrice (in kg)  
C = Massa Rimorchiabile Max. della motrice (in kg)

## DA COMPILARE PER IL COLLAUDO

**DICHIARAZIONE DI CORRETTO MONTAGGIO** : la sottoscritta Ditta dichiara di aver montato in maniera corretta ed in conformità alle prescrizioni sia del costruttore del veicolo che del costruttore del dispositivo stesso il seguente dispositivo di attacco meccanico :

tipo : .....  
Il dispositivo di attacco sopra indicato è stato installato su autoveicolo  
modello : .....  
targa : .....  
Data : .....

**TIMBRO e FIRMA**

**Si dichiara inoltre di aver informato l'utente del veicolo sull'USO e MANUTENZIONE del dispositivo stesso.**

Dispositivo di traino tipo : **16 133 621 80 / 98 216 187 80**  
Per autoveicolo : **PEUGEOT 308**  
Tipo funzionale : **L\*\*\*\*\*-C\*\*\*\*\***

Classe e tipo di attacco : **A50-X**  
Omologazione : **e24\*R55 01 0316**  
Valore D : **8,58 kN**  
Carico verticale max. S : **75 kg**  
Larghezza rimorchiabile per Caravan e T.A.T.S. : 2,55m vedere CARTA di CIRCOLAZIONE VEICOLO (motrice) + 70cm = ...arrotondare ai 5cm superiore (vedi D.M.28/05/85)  
Massa rimorchiabile : vedi carta di circolazione dell'autoveicolo

**Per verificare l'idoneità del dispositivo di traino omologato a norma CEE R55, all'installazione sulla vettura su cui si intende procedere al montaggio, compilare la seguente formula (se necessario declassare la massa rimorchiabile) :**

$$D = \frac{T \times C}{T + C} \times 0,00981 < 8,58 \text{ kN}$$

dove : T = Massa Complessiva Max. della motrice (in kg)  
C = Massa Rimorchiabile Max. della motrice (in kg)

## DA COMPILARE PER IL COLLAUDO

**DICHIARAZIONE DI CORRETTO MONTAGGIO** : la sottoscritta Ditta dichiara di aver montato in maniera corretta ed in conformità alle prescrizioni sia del costruttore del veicolo che del costruttore del dispositivo stesso il seguente dispositivo di attacco meccanico :

tipo : .....  
Il dispositivo di attacco sopra indicato è stato installato su autoveicolo  
modello : .....  
targa : .....  
Data : .....

**TIMBRO e FIRMA**

**Si dichiara inoltre di aver informato l'utente del veicolo sull'USO e MANUTENZIONE del dispositivo stesso.**



Communication concerning<sup>1</sup>  
 Approval granted  
 Approval extended  
 Approval refused  
 Approval withdrawn  
 Production definitively discontinued

of a type of mechanical coupling device or component pursuant to Regulation No.55.

Approval No: **E24 55R-010315**

Extension No. **02**

Reason for extension:

*- Increase of D-value*

1. Trade name or mark of the device or component: **SLARR or Westfalia or Monoflex**
2. Manufacturer's name for the type of device or component: **SI199**
3. Manufacturer's name and address: **SLARR SAS  
F-76810 Luneray  
France**
4. If applicable, name and address of the manufacturer's representative: **N/A**
5. Alternative supplier's name or trade mark applied to the device or component: **N/A**
6. Name and address of the company or body taking responsibility for the conformity of production: **See 3. above**
7. Submitted for approval on: **As before and 25.01.2017**
8. Technical service responsible for conducting approval tests: **TÜV SÜD Auto Service GmbH,  
Westendstraße 199,  
D-80686 München,  
Germany.**
9. Brief description: **Type: Non-standard coupling ball 50  
Class: A50-X**

<sup>1</sup> Smalls not what does not apply.

Approval No: **E24 55R-010315**

Extension No. **02**

9.2 Characteristic values

9.2.1 Primary values: D: **8.58 kN**  
 Dc: **--**  
 S: **75 kg**  
 U: **--**  
 V: **--**

Alternative values:

D: **--**  
 Dc: **--**  
 S: **--**  
 U: **--**  
 V: **--**

9.3 For Class A mechanical coupling devices or components, including towing brackets:

**1930 kg**

Vehicle manufacturer's maximum permissible vehicle mass:

**Front:1070 kg / Back:900 kg**

Distribution of maximum permissible vehicle mass between the axles:

**1600 kg**

Vehicle manufacturer's maximum permissible towable trailer mass:

**75 kg**

Vehicle manufacturer's maximum permissible static mass on coupling ball:

**1518 kg**

Maximum mass of vehicle, with bodywork, in running order, including coolant, oils, fuel, tools and spare wheel (if supplied)but not including driver.

Loading condition under which the tow ball height of a mechanical coupling device fitted to category M1 vehicles is to be measured – see paragraph 2 of annex 7, appendix 1: **Dimensions given by the vehicle manufacturer.**

**N/A**

For class B coupling heads, is the coupling head intended to be fitted to an unbraked O1 trailer: (yes/no)

10. Instructions for the attachment of the coupling device or component type to the vehicle and photographs or drawings of the mounting points given by the manufacturer

**See manufacturer's documentation.**

11. Information on the fitting of any special reinforcing brackets or plates or spacing components necessary for the attachment of the coupling device or component:

**See manufacturer's documentation.**

12. Additional information where the use of coupling device or component is restricted to special types of vehicles - see annex 3, paragraph 3.4:

13. For Class K hook type couplings, details of the drawbar eyes suitable for use with the particular hook type:

14. Date of test report:

15. Number of test report:

16. Approval mark position:

17. Reason(s) for extension of approval:

18. Approval ~~granted/extended/refused/withdrawn~~:

19. Place:

20. Date:

21. Signature:



22. The list of documents deposited with the Administration Service which has granted approval is annexed to this communication and may be obtained on request.

See manufacturer's documentation.

N/A

As before and 23.01.2017

13-00418-CX-GBM- up to 02

Manufacturer's plate on socket plate, riveted.

- Increase of D-value

Extended

Dublin

31<sup>st</sup> January, 2017.

**E24**

Communication concerning<sup>1</sup>

-Approval granted  
-Approval extended  
-Approval refused  
-Approval withdrawn  
-Production definitively discontinued

of a type of mechanical coupling device or component pursuant to Regulation No.55.

Approval No: E24 55R-010316

Extension No: 02

Reason for extension:

- Increase of D-value

1. Trade name or mark of the device or component:

SLARR or Wesifalia or Monoflex.

2. Manufacturer's name for the type of device or component:

SI200

3. Manufacturer's name and address:

S.I.A.R.R. S.A.S  
F-76810 Luneray  
France.

4. If applicable, name and address of the manufacturer's representative:

N/A

5. Alternative supplier's names or trade marks applied to the device or component:

N/A

6. Name and address of the company or body taking responsibility for the conformity of production:

See 3. above.

7. Submitted for approval on:

As before and 25.01.2017

8. Technical service responsible for conducting approval tests:

TÜV SÜD Auto Service GmbH,  
Westendstraße 199,  
D-80686 München,  
Germany.

9. Brief description

9.1 Type and class of device or component:

Type: Non-standard coupling ball 50  
Class: A50-X

<sup>1</sup> Strike out what does not apply.

9.2 Characteristic values

9.2.1 Primary values:

D: **8.58 kN**  
Dc: --  
S: **75 kg**  
U: --  
V: --

Alternative values:

D: --  
Dc: --  
S: --  
U: --  
V: --

9.3 For Class A mechanical coupling devices or components, including towing brackets:

Vehicle manufacturer's maximum permissible vehicle mass: **1930 kg**

Distribution of maximum permissible vehicle mass between the axles:

**Front: 1070 kg / Back: 900 kg**

Vehicle manufacturer's maximum permissible towable trailer mass:

**1600 kg**

Vehicle manufacturer's maximum permissible static mass on coupling ball:

**75 kg**

Maximum mass of vehicle, with bodywork, in running order, including coolant, oils, fuel, tools and spare wheel (if supplied) but not including driver:

**1518 kg**

Loading condition under which the tow ball height of a mechanical coupling device fitted to category M1 vehicles is to be measured – see paragraph 2 of annex 7, appendix 1:

**Dimensions given by the vehicle manufacturer.**

9.4 For class B coupling heads, is the coupling head intended to be fitted to an unbraked O1 trailer: (yes/no)

**N/A**

10. Instructions for the attachment of the coupling device or component type to the vehicle and photographs or drawings of the mounting points given by the manufacturer

**See manufacturer's documentation.**

11. Information on the fitting of any special reinforcing brackets or plates or spacing components necessary for the attachment of the coupling device or component:

**See manufacturer's documentation.**

12. Additional information where the use of coupling device or component is restricted to special types of vehicles - see annex 5, paragraph 3.4:

**See manufacturer's documentation.**

13. For Class K hook type couplings, details of the drawbar eyes suitable for use with the particular hook type:

**N/A**

14. Date of test report:

**As before and 23.01.2017**

15. Number of test report:

**13-00419-CX-GBM- up to 02**

16. Approval mark position:

**See manufacturer's installation instructions.**

17. Reason(s) for extension of approval:

**Increase of D-value**

18. Approval ~~granted/extended/refused/withdrawn~~:

**Extended**

19. Place:

**Dublin**

20. Date:

**31<sup>st</sup> January, 2017.**

21. Signature:



22. The list of documents deposited with the Administration Service which has granted approval is annexed to this communication and may be obtained on request