

# SL4K-E01

## Introduction

Let me introduce this nice Preamp in the style of a British Console Preamp. I have designed this familiar Preamp in 500 API compatible format. It works in 500 VPR or 51X Lunchboxes on the +16V and -16V rails. I mainly used the schematic of the 4000E-E01 with an extra That 1646 Outputstage. In my version I added variable High Pass and Low Pass Filters. For full flexibility in colouring sound with this Preamp Module we added the DIYRE Colour Module Standard. This Guide will help with setting up this nice Preamp. Have Fun!

## TABLE OF CONTENTS

Introduction	1
Functions	2
PAD Options	3
Stuffing Boards	3
Potentiometers and Switches	5
Final Assembly	6
Calibration	9
PCB layout for reference	10
Schematics	11
Bill of Materials (BOM)	13

**DISCLAIMER:** Proceed at your own risk. I am not liable for any damage, harm or loss of any kind resulting from the assembly and/or use of this PCB set. Safety provisions should always be exercised whenever working with any electronics. The following instructions are guidelines only. I can make no guarantee of the accuracy of contents contained within this document.

# Functions

This Stepped Pot sets the amount of Mic-Gain achieved with the Preamp

This Switch enables Phantom Power

This Switch enables a 20dB PAD

This Switch changes the Polarity of the Output Signal

This Switch enables the High Pass Filter

This Switch enables the Low Pass Filter

This Switch enables the Colour Module

This Pot sets the Level of the Output Signal in a Range of -100dB to +12dB



The Peak LED is pre set to +18dBu directly after Preamp

The LED Meter can be set up PRE or POST FADER. Next to the Bus Cable of the LED Meter Board it can be Jumpered to the selected Feature. All the Levels are set in dBu

This Pot sets the Frequency of the Low Cut Filter in a range of 10 Hz to 250 Hz

This Pot sets the Frequency of the High Cut Filter in a range of 3.5kHz to 20 kHz

This Pot sets the amount of driving your Signal with the Colour Module

## PAD Options

All the Pad-Resistors which are included in the Kit are selected like in the Original schematic. Due to many requests we show an option on how to mod the PAD switch to a Line- to Mic-Level Switch. The Impedance is more important for a Line Level Signal, so we choose two 5k1 Resistor as series Resistors and the Shunt Resistor has to be changed for the desired Level of Attenuation.

For using the Preamp in Line Mode we set it at a **GAIN SETTING of 42 dB**. In this Configuration. Line Level is at Unity at the In- and Output.

### Resistor changes

R\_PAD3 - 5k1

R\_PAD1 - 5k1

R\_PAD2 - 56R

R\_PAD4 - No Resistor

## Stuffing Boards

We will place Components on the Main Board and on the LED Meter Subboard. First Step is to place all Resistors and Diodes. Check before Soldering if your Diode-Placement is right. **But Before we do that you need to choose if you want to use a Yellow LED or a RGB LED for the Colour Module.**

### Using a RGB LED

Add a Small Solder Joint on the Back of the PCB near the Colour Module Connector. Don't use the 6K81/OPT Resistor called R\_C\_RGB1 on the Board. We will install the RGB LED later in the build process

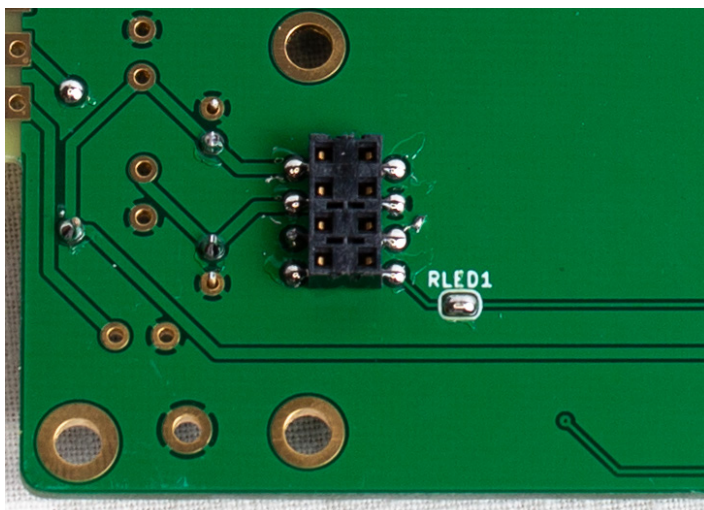

### Using a Yellow LED

We don't add the Solder Joint on the back but we use the 6K81/OPT Resistor called R\_C\_RGB1 on the Board. We will install the Yellow LED later in the build process

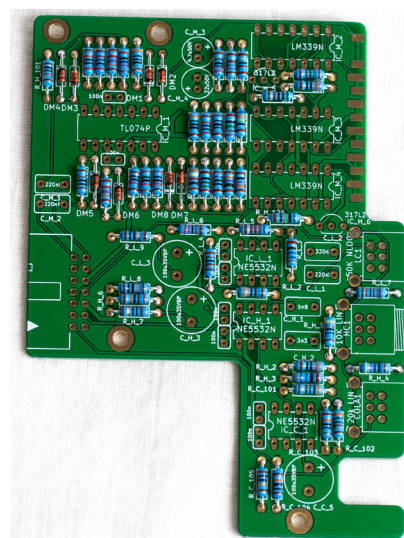
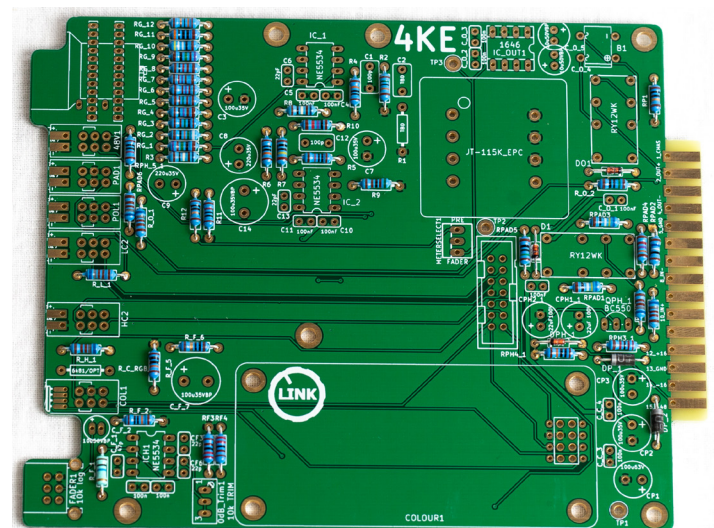
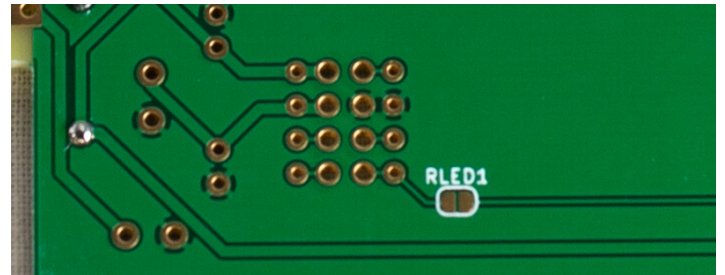

After Placing and Soldering all Resistors, we solder the next bigger parts like IC-Sockets and small capacitors, like Yellow 100nF and capacitors next to IC Sockets.

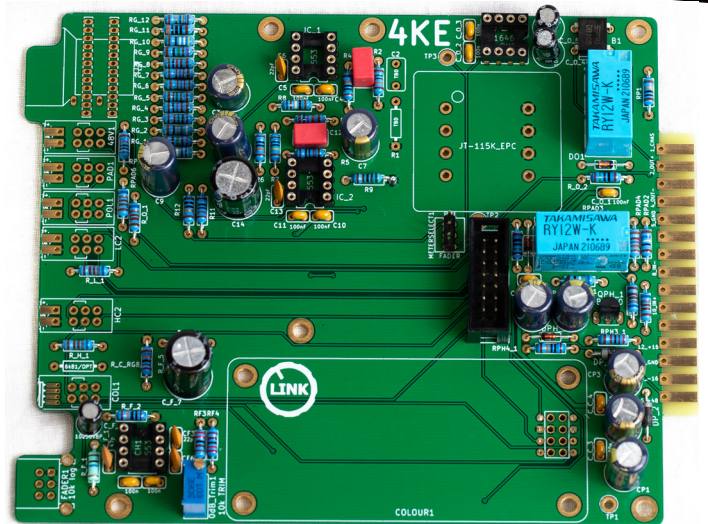
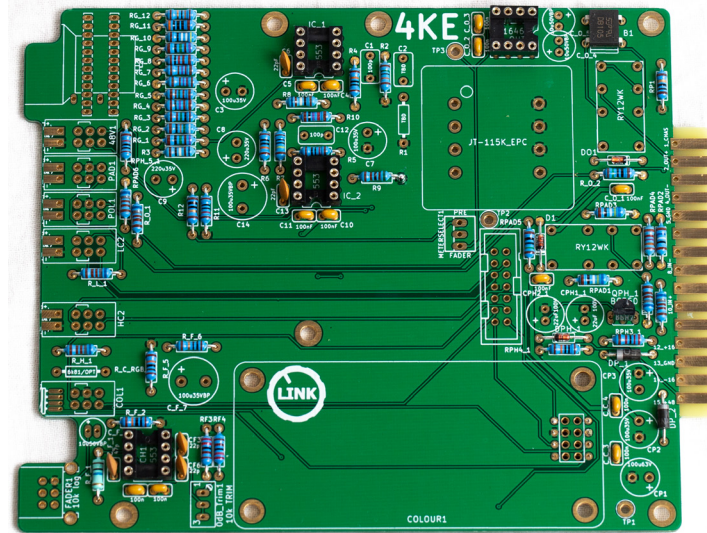

On the LED Meter Board we also add the electrolytics and Wima Capacitors and Board connections, and cut leads after soldering as short as possible. We will do this process later with Potentiometers also, since we need to make sure that this Preamp doesn't touch any neighbour modules of any kind.

Continue on the LED Meter Board and add all Sockets. Normally we solder first one pin in and trim all of the other Pins as short as possible and continue after that with soldering all other pins on that Board.

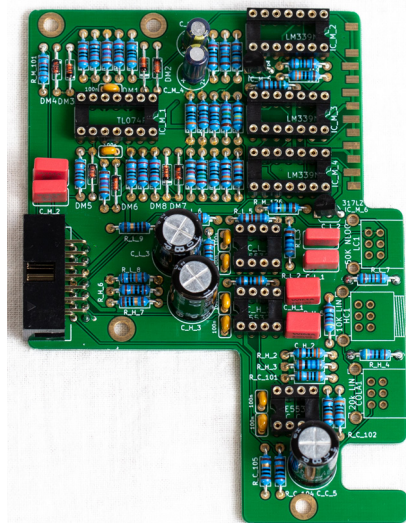
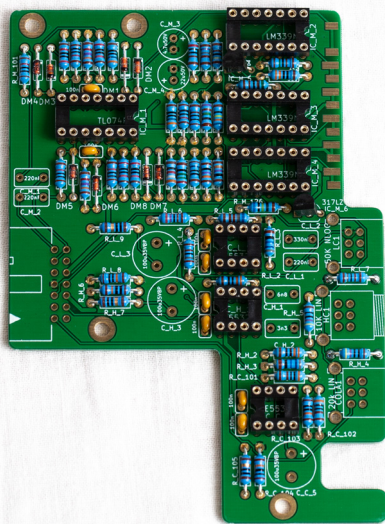

After that Step solder all Wima Capacitors, Electrolytics and Board Connectors as on the pictures.

At this point we should clean our board and give the board and us a bigger break. Cleaning boards can be done with alcohol/water/your preferred method. But don't clean the Board after Trimpots, Switches and Pots are installed. Trimpots, Switches, Potentiometers don't like cleaning and that can lead to problems with electrical contact.

## Potentiometers and Switches

Now we will continue with the LED Meter Board first. We add the three Potentiometers to their described positions. Check the pictures if you are not sure which Pots goes on which position. It is important to press them in place during Soldering, we need them to sit flush and straight because of the mechanical assembly later. Put all pots on the PCB and solder just one pin. After Soldering one Pin make sure the alignment of the pot is straight. You can check that with the printed silkscreen on the PCB. We don't solder the other Pins at this point to make a final alignment later on.

If not already done before we cut all leads on the upper subboard as short as possible.

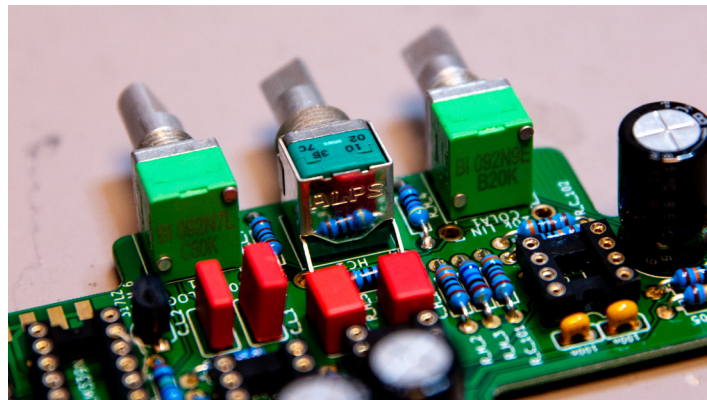
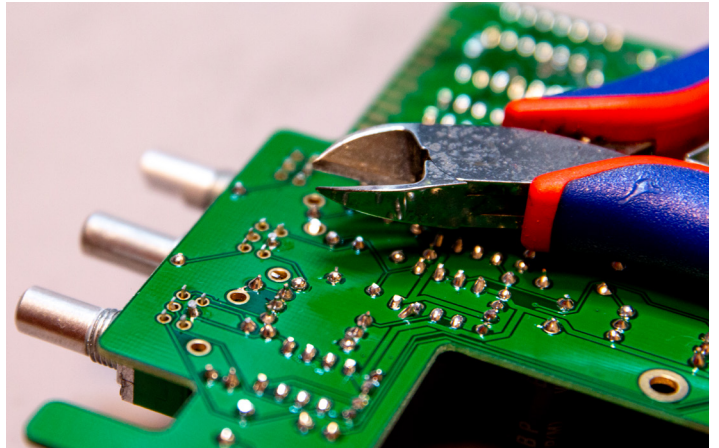

The next step is focusing on the Pot, Grayhill switch and Pushbutton Switches of the Mainboard. Again we will solder just one solder point of each part to bring the Pot/Switch in the right direction and will solder the rest of the Pins later on in the Final Assembly. You can also solder the Transformer in.

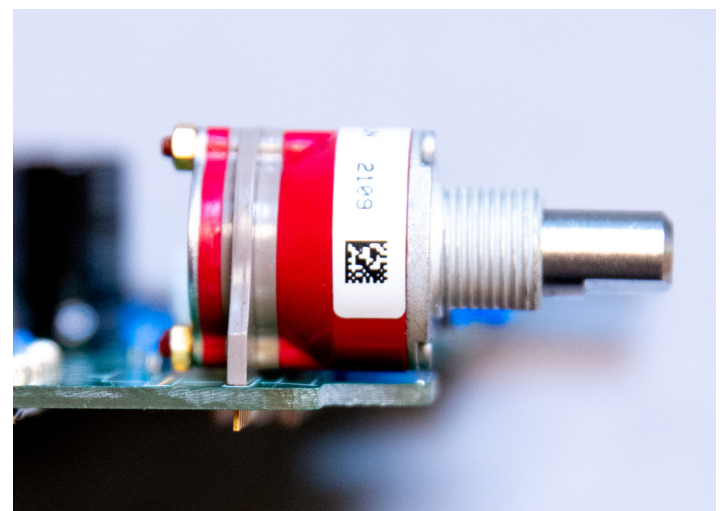
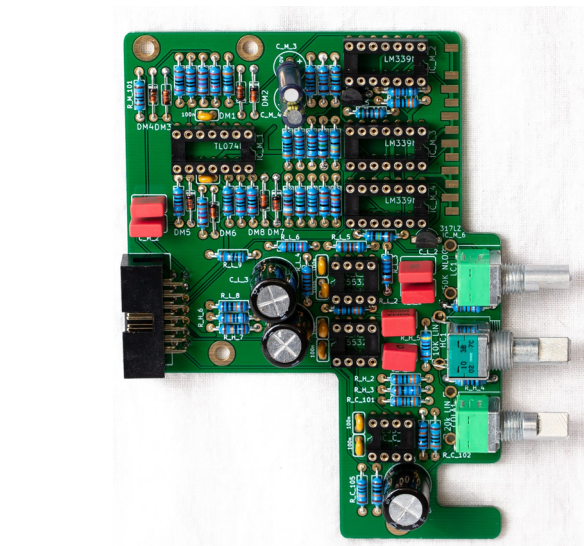
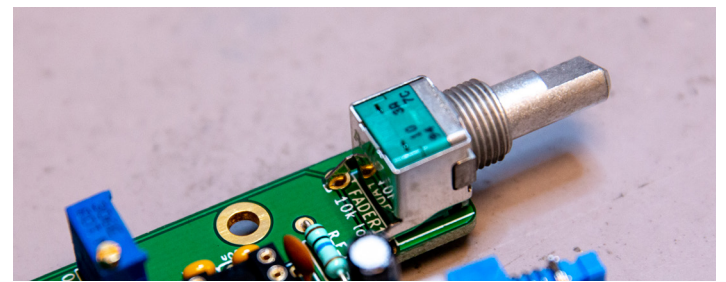
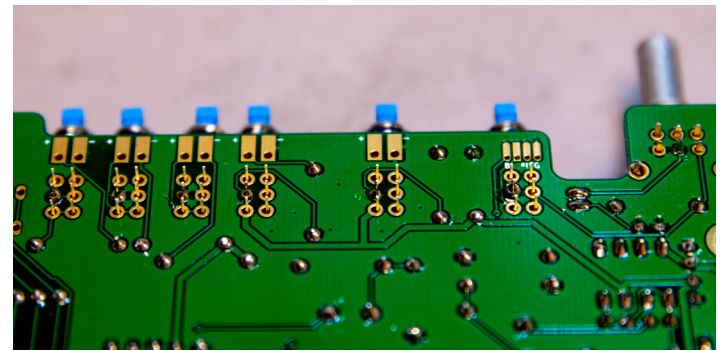
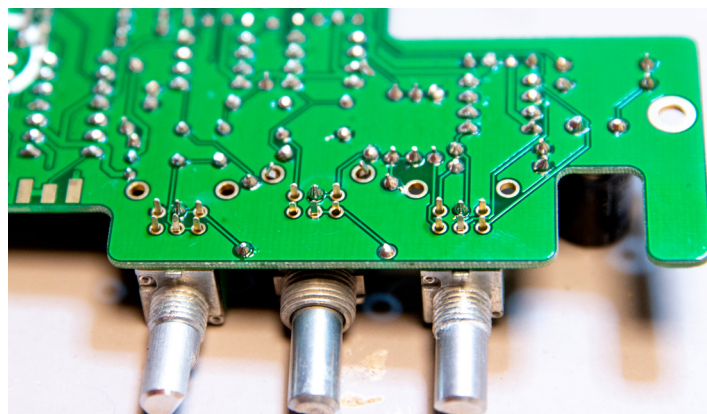

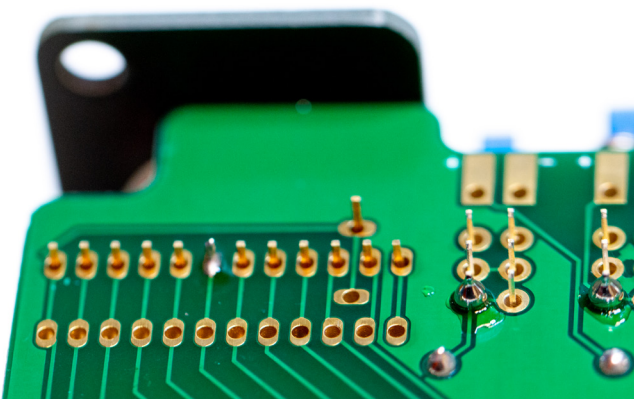

Now we will add one Stop Pin to the 12 o' clock Position of the Grayhill Switch and will tape the Switches Stop Pins with the Sticker so they can't move anymore.

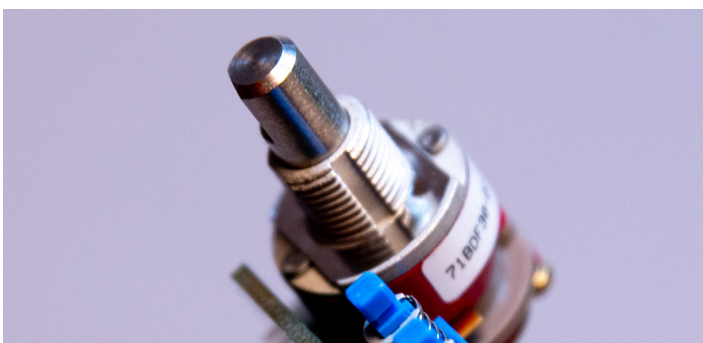
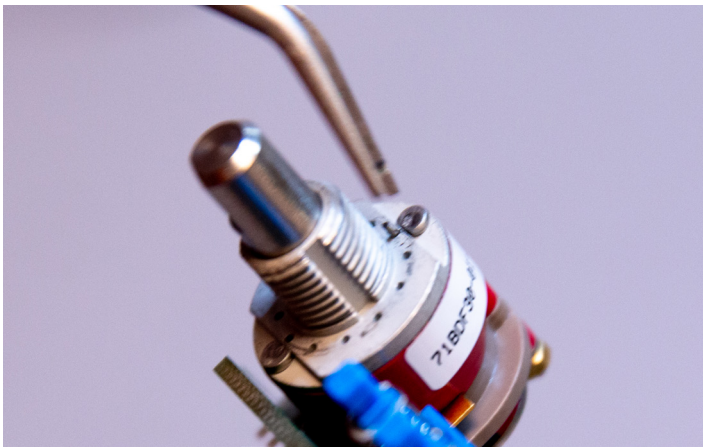

Check the alignment of the Switches and the Pots from upside again and try to align it to the silkscreen as good as possible. After that install the bracket on the Mainboard to make sure everything is in place.

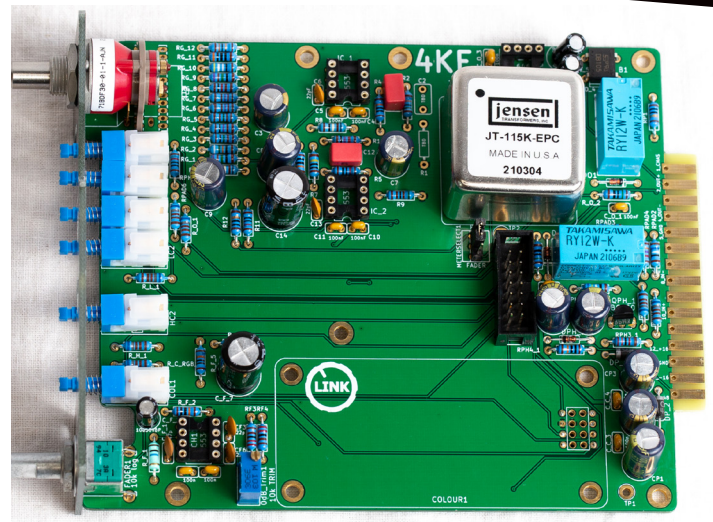

## Final Assembly

Now it's time to use the Frontpanel for the first time to get the Switches and LEDs in place. Use the spacers and bring the Frontpanel in place with just the Mainboard. You should use the nuts to screw them together. Install the pushbuttons and rearrange the switches on the PCB until they are in the middle of the hole of the Frontpanel. After this process you can solder them in completely. After soldering in all of the Pots and Switches make sure that their leads are also trimmed short.

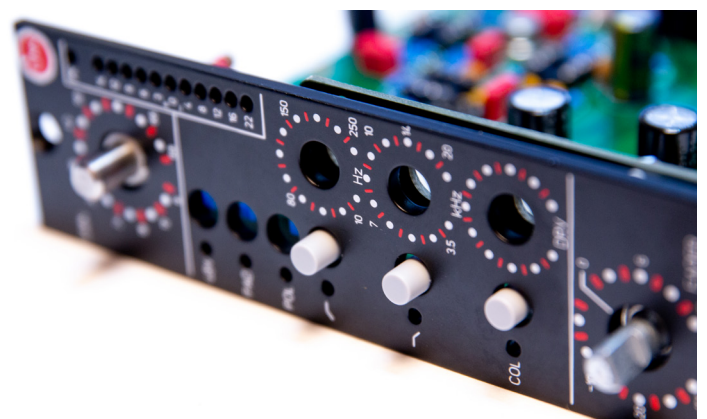
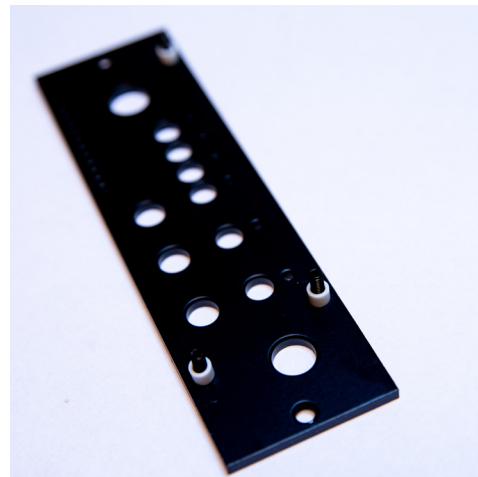

For the next Step we will use some paper masking tape to perfectly place all the LEDs. Place the tape just where the LEDs will be installed.

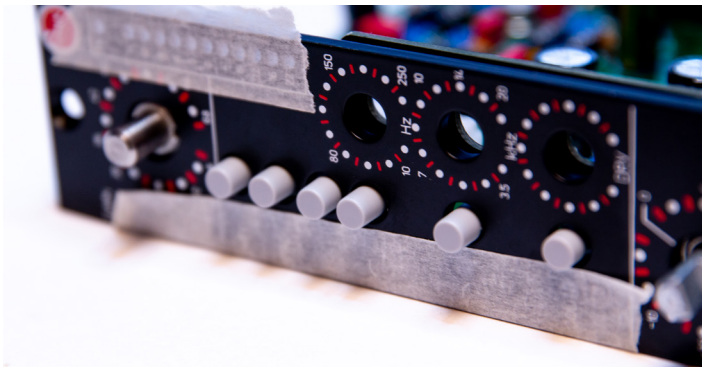

Now we will cut the LEDs legs. Make sure you have the right leg for + and - ( Long leg is + and short leg is -). I usually don't cut them straight and keep two different size legs, so you still know which leg is + and which is -. For the Mainboard we need LEDs with long leg measured cut to 8-10mm (5/16 to 6/16)

For the Mainboard we need:

- 1x RED
- 2x GREEN
- 2x YELLOW
- 1x RGB or YELLOW

For the LED Meter we need LEDs with long leg measured cut to 12-14mm (8/16 to 9/16)

For LED-Meter we need:

- 2x RED
- 6x GREEN
- 4x YELLOW

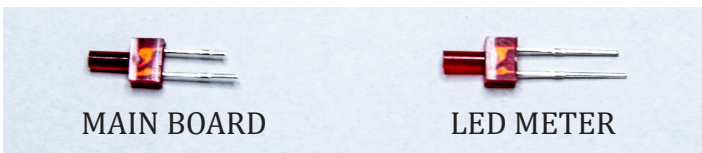

For the RGB LED I usually leave the Ground leg longer. that's also the longest leg before cutting.

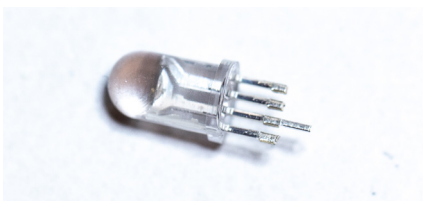

Make sure the LED is sitting flush with the frontpanel in one level. First solder one leg to make sure the LED is in place, then solder the other leg(s).

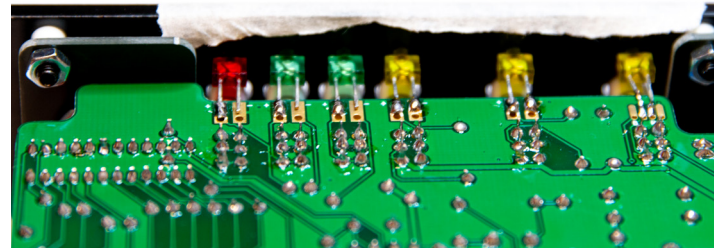

If you choose a yellow LED for Colour Module indication solder the long leg to R/Y and the short leg to the unlabeled Pin. If you want to solder RGB check the picture below.

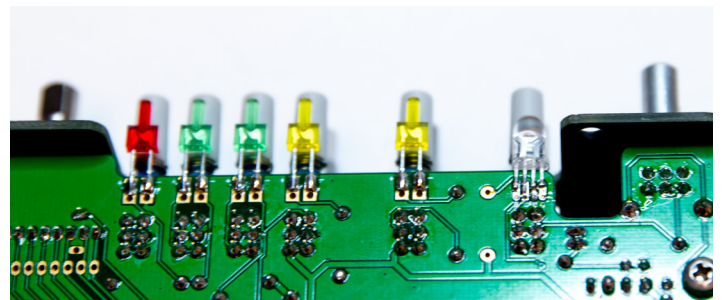

After soldering all LEDs tot the Mainboard unscrew the Frontpanel again. Put the 25mm Spacers on the Mainboard and add the LED-Meter Board. Use the screws to secure the LED-Meter Board. Put the Frontpanel back on again and tighten the Nuts to the bracket. Now we will finally solder the remaining legs of the Pots as they should be perfectly centered now.

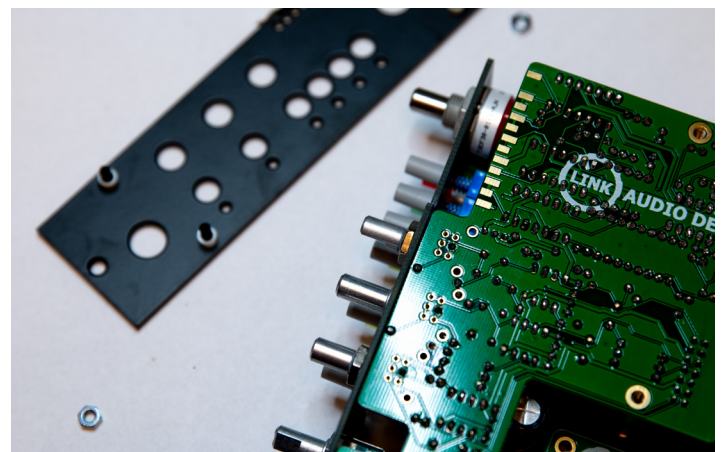

After that we will install all of the Meter LEDs. The Meter-LEDs Solder Points have short and long dashes. A long dash is + and is meant for the long leg of the LED. Short dash means - and the short leg of the LED. Add all LEDs step by step and solder them all just from the top. After installing all LEDs remove the Frontpanel again and Solder all points from the backside of the LED-Meter Board.

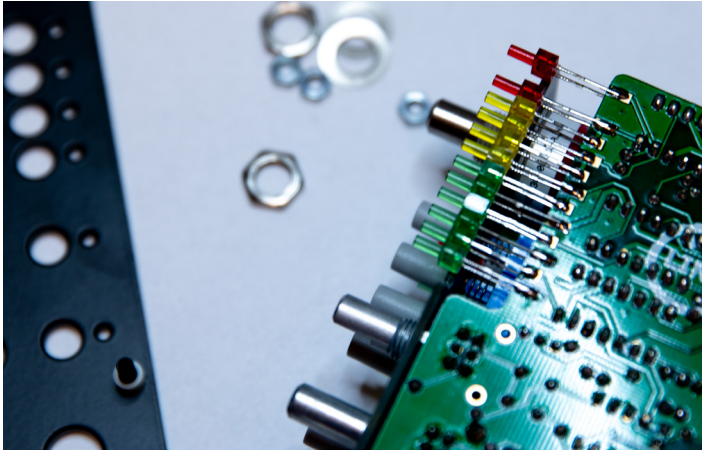

**11 mm Red - Colour Module**  
**11 mm Blue Caps - LOW and HIGH PASS**  
**15 mm Red - Output Fader**  
**15 mm Blue - Gain**

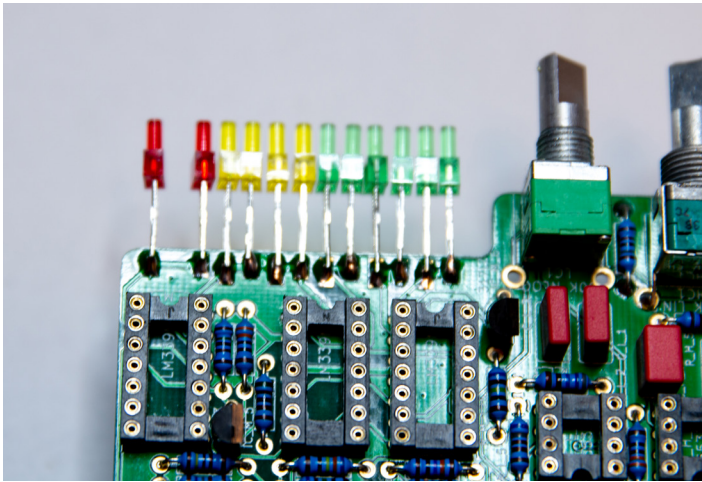
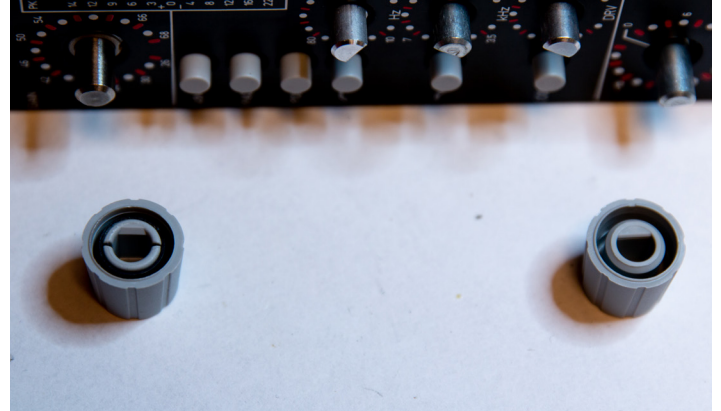

Now we have soldered all parts and want to check without IC and Opamps installed if the Voltages are on the right. For that we don't use the Frontpanel or the bracket. We use the ribbon cables to connect the boards. Use an adapter for your lunchbox/or power it up on another way to measure all Voltages near the ICs. The Voltage Meter should show something like +/-15,3V, because of the drop of the diodes at the power input. Check if the LEDs are working and the relays are switching. Without LM339 inserted all Meter-LEDs should light up. If everything seems good install the ICs. **IMPORTANT:** Check the Orientation of each IC before installing. Check also which Opamp goes where. There are different Opamps used in the whole unit.

Now it's time to add the Frontpanel to complete the Preamp. Use the spacers and the M3 Nuts to finish it. There are two different 15mm Knobs for Gain and Output Fader, check that you use the right one for each Pot. The 11mm Knobs going to High Cut, Low Cut and Colour Module. The Caps for the Knobs are sorted as following:



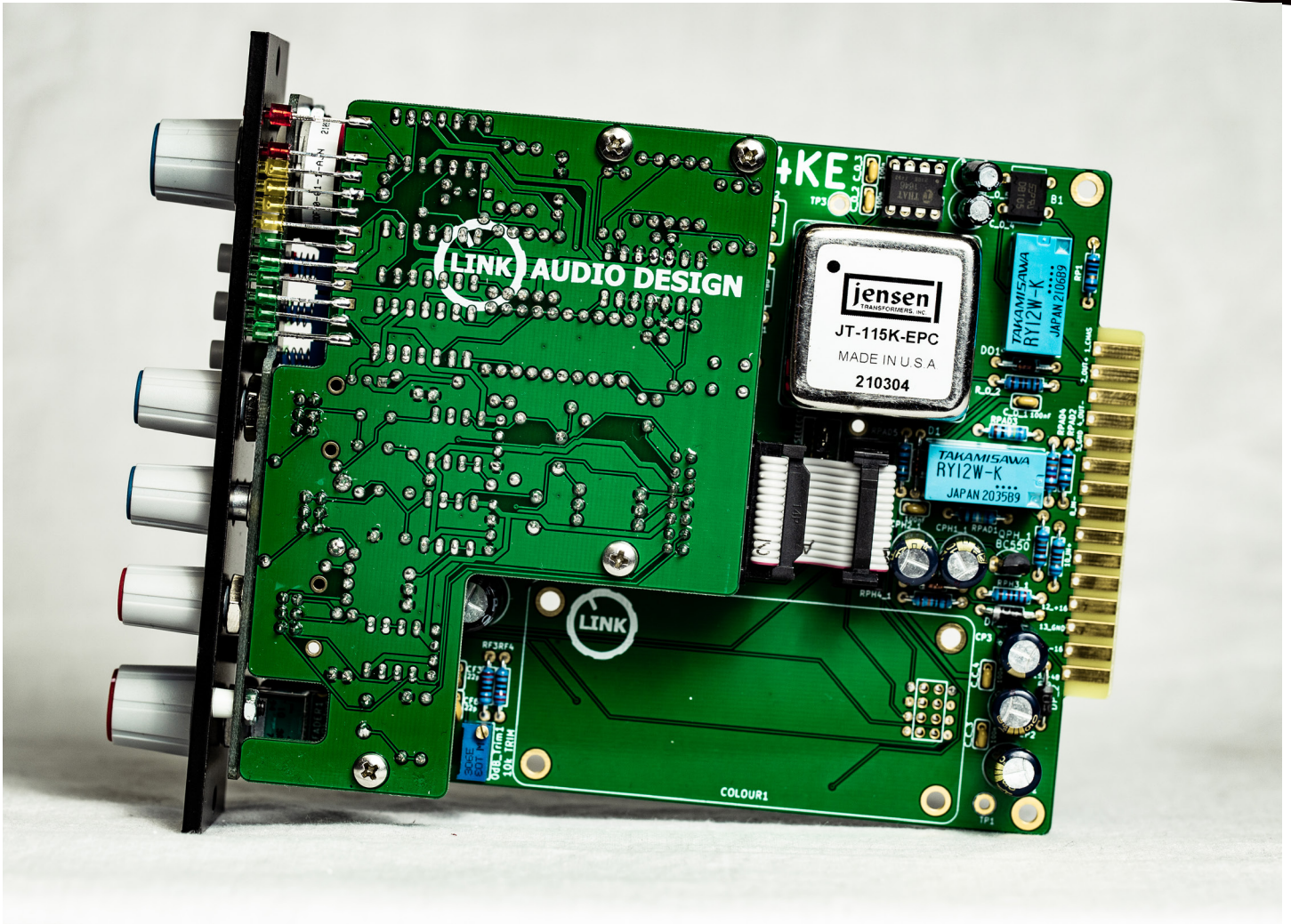

After finishing try to run an Audio Signal thru the Unit and try all switch modes, if everything works fine. In the next step we will calibrate this wonderful Preamp.

## Calibration

Calibration of this unit is no Rocket Science and it's quite easy. You just need to play a Sinus tone in different levels and frequencies. Make sure you have enough headroom that you don't get clipping when capturing the response of the Preamp. This works with every DAW but the easiest way to calibrate this Preamp is using the freeware software REW.

### Calibrating 0dB Output Fader to Zero

Set the LED Meter to PRE FADER MODE with the jumper on the Board. Set the Oscillator frequency to 1kHz and send a signal to the unit. Adjust just the Gain of the unit. Reduce or add more Level from your generator until The LED Meter reads exactly 0dB. Then use your multimeter to read out a Volta-

ge in AC Mode between Testpoints 1 and 2. TP1 is GND and TP2 is the Preamps Out. You should read around 700mV. Now set your Output Fader to exactly 0dB and read out the Voltage between TP1 and TP3. Now adjust the 0dB Trimpot on the bottom of the board until both Voltages at TP2 and TP3 are the same. After this calibration you can set the LED -Meter to PRE or POST FADER Mode. The Calibration just need some minutes to be done. Congratulation to your finished Preamp!



# Schematics

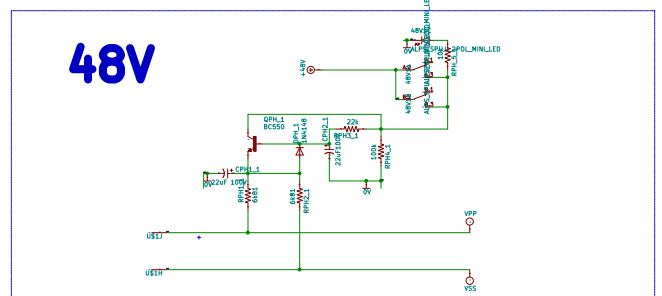
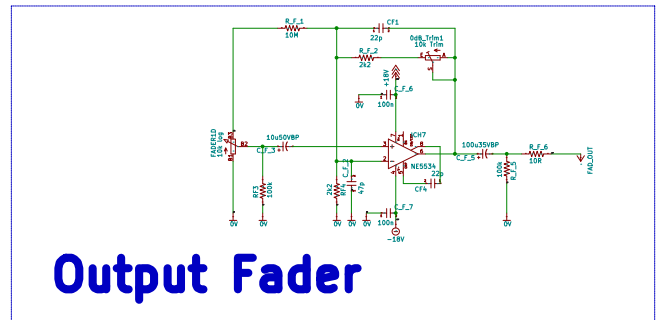
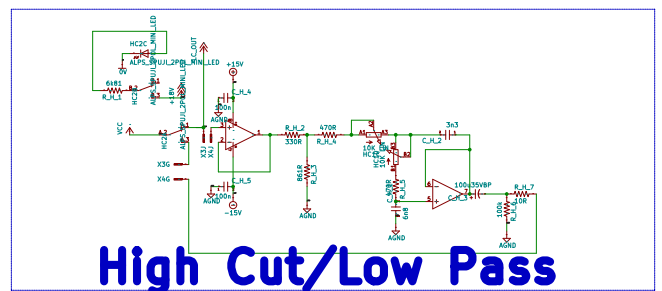
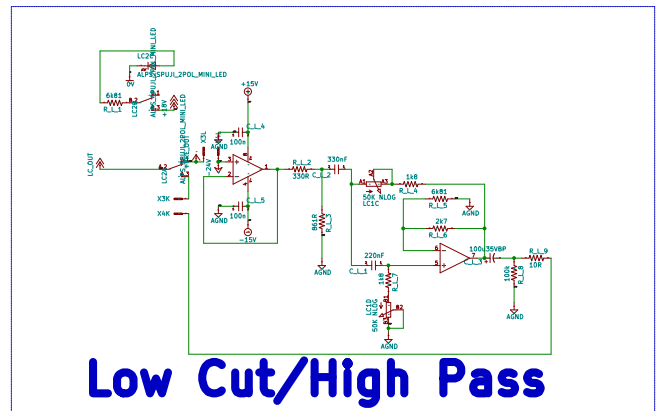
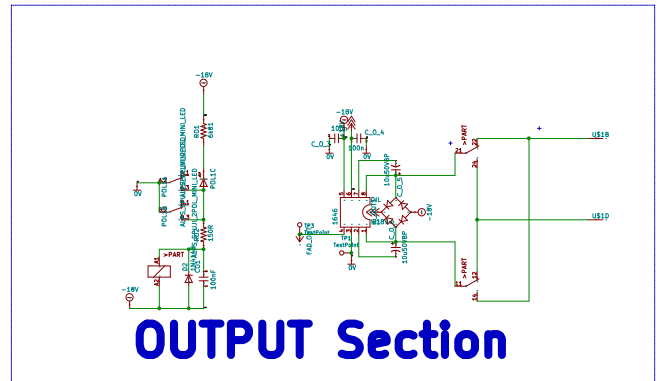
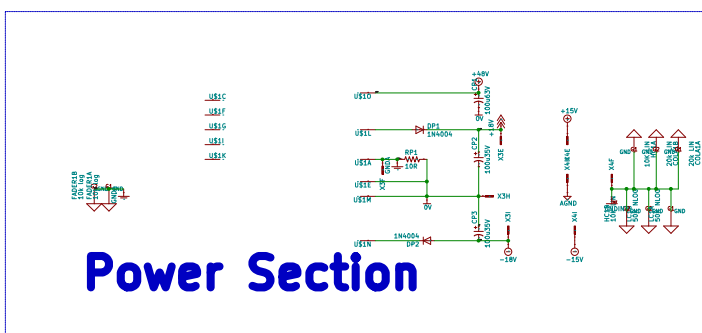
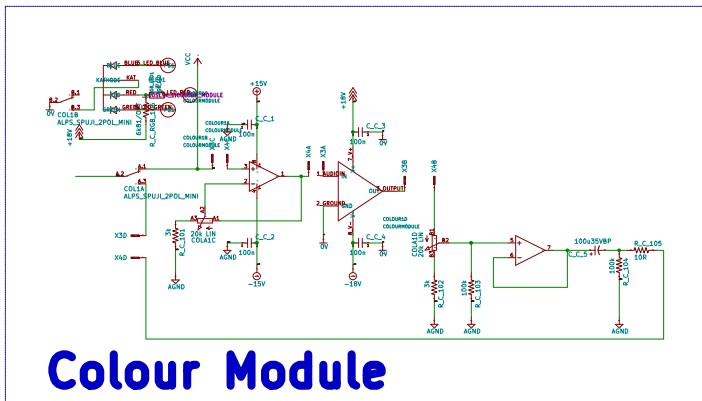
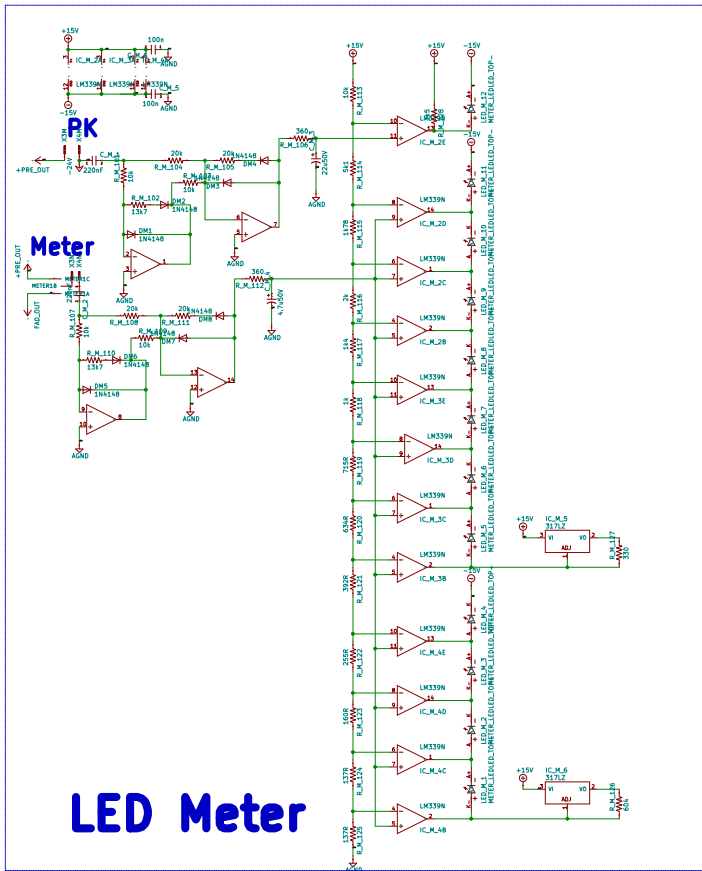

# Schematics

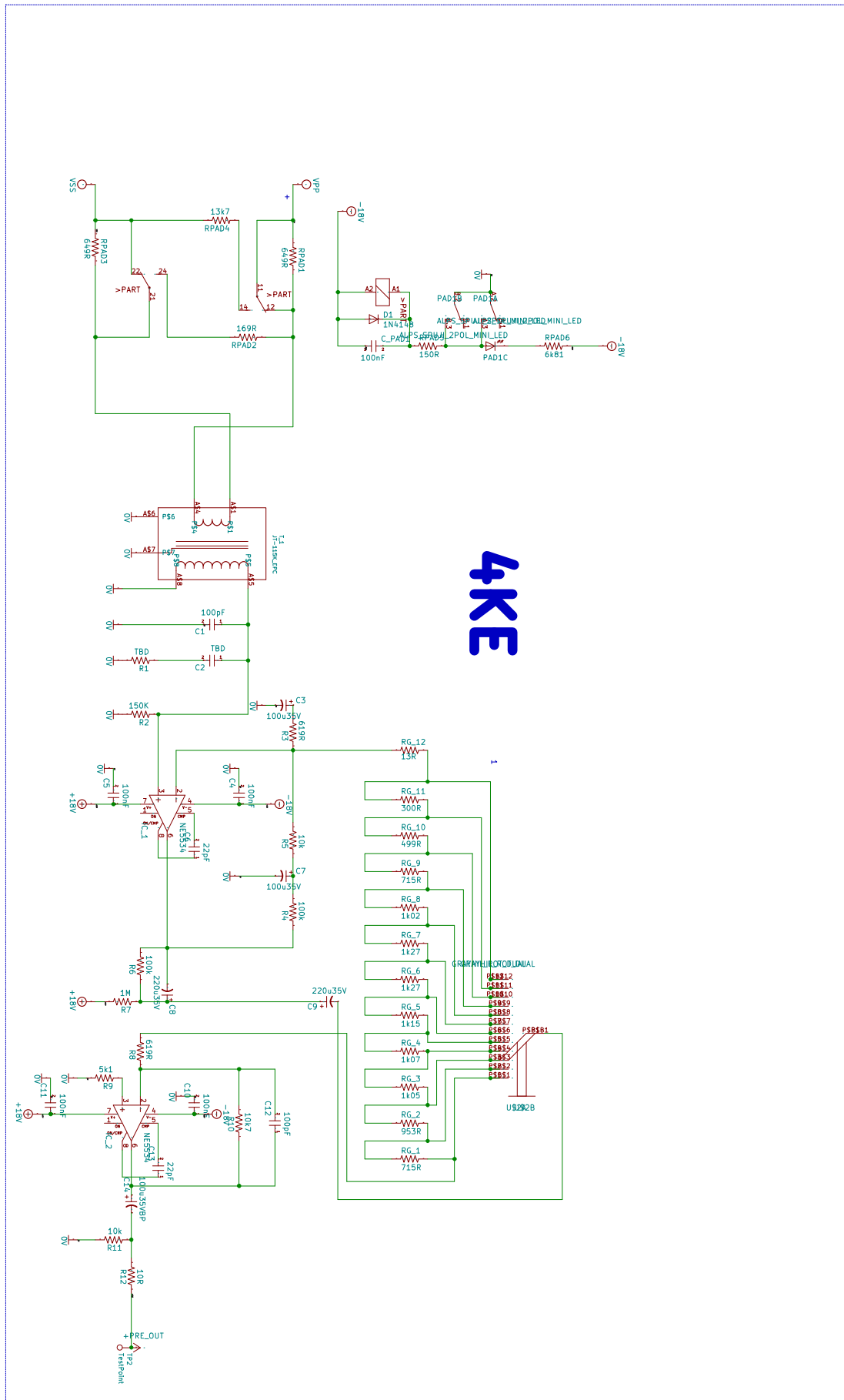

## Bill of Materials (BOM)

<b>Preamp Base</b>			
<b>PART ON PCB</b>	<b>TYPE</b>	<b>COUNT</b>	<b>VALUE</b>
	<b>BAG</b>	<b>1</b>	
R_C_105,R_L_9,R_H_7,RP1,R_F_6,R32	Resistor	6	10R
R_M_125,R_M_124	Resistor	2	137R
R_M_123	Resistor	1	160R
R_L_5,RPAD9,R01,RPH2_1,R_H_1,RPH1_1,R_L_1,R_C_RGB_106	Resistor	8	6k81
METERSELECT	Pin Header	1	Pin Header
METERSELECT	Jumper	1	Jumper
	<b>BAG</b>	<b>2</b>	
RPAD5,R02	Resistor	2	150R
R_M_122	Resistor	1	255R
R_H_2,R_L_2,R_M_127	Resistor	3	330R
R_M_101,R_M_103,R_M_113,R_M_109,R_M_107,RPH_5_1	Resistor	6	10k
QPH_1	Transistor	1	BC550
	<b>BAG</b>	<b>3</b>	
R_M_102,R_M_110	Resistor	2	13k7
R_M_105,R_M_111,R_M_108,R_M_104	Resistor	4	20k
RPH3_1	Resistor	1	22k
R_C_103,R_H_6,R_L_8,R_C_104,RPH4_1,RF2,R_F_5	Resistor	7	100k
R_F_1	Resistor	1	10M
	<b>BAG</b>	<b>4</b>	
R_M_106,R_M_112	Resistor	2	360R
R_M_121	Resistor	1	392R
R_H_4,R_H_5	Resistor	2	470R
R_M_126	Resistor	1	604R
DM6,DM1,DM4,DM2,DM3,DM5,DM8,DM7,D2,DPH_1,DPAD1	Diode	11	1N4148
	<b>BAG</b>	<b>5</b>	
R_M_118	Resistor	1	1k
R_M_128	Resistor	1	1k5
R_M_115	Resistor	1	1k78
R_L_7,R_L_4	Resistor	2	1k8
R_M_116	Resistor	1	2k

<b>PART ON PCB</b>	<b>TYPE</b>	<b>COUNT</b>	<b>VALUE</b>
	<b>BAG</b>	<b>6</b>	
R_L_6	Resistor	1	2k7
R_C_102,R_C_101	Resistor	2	3k
R_M_114	Resistor	1	5k1
R_M_120	Resistor	1	634R
DP1,DP2	Diode	2	1N4004
	<b>BAG</b>	<b>7</b>	
R_M_117	Resistor	1	1k4
R_M_119	Resistor	1	715R
R_L_3,R_H_3	Resistor	2	861R
R_F_3,RF4	Resistor	2	2k2
IC_M_6,IC_M_5	Regulator	2	317LZ
	<b>BAG</b>	<b>8</b>	
C_C_2,C_L_4,C_H_4,C_H_5,C_L_5,C_C_1,C_M_6,C_M_5,C_O_3, C_O_4,C_F_7,C_F_6,C_C_3,C_C_4,C_PAD1,CO1	Ceramic 2,5mm	16	100nF
CF4,CF1	Kerko 2,5mm	2	22p
C_F_2	Kerko 2,5mm	1	47p
C_M_2,C_L_1,C_M_1	Wima 5mm	3	220nF
C_H_1	Wima 5mm	1	6n8
C_L_2	Wima 5mm	1	330nF
C_H_2	Wima 5mm	1	3n3
	<b>BAG</b>	<b>9</b>	
C_F_3,C_O_5,C_O_6	Electrolytic Bipolar	3	10u50VBP
C_M_3	Electrolytic	1	4.7u50V
C_M_4	Electrolytic	1	22u50V
CPH1_1,CPH2_1	Electrolytic	2	22uF100V
CP2,CP3	Electrolytic	2	100u35V
CP1	Electrolytic	1	100u63V
C_C_5,C_H_3,C_L_3,C_F_5,(C14,C27,C310)	Electrolytic Bipolar	5	100u35VBP
KPAD1,KPOL1	Relais	2	RY12WK
COL1,HC2,LC2,POL1,PAD1,48V1	Switch	6	ALPS_SPUJI_2

<b>PART ON PCB</b>	<b>TYPE</b>	<b>COUNT</b>	<b>VALUE</b>
	<b>BAG</b>	<b>10</b>	
Socket GS8	Socket Opamp	5	Socket GS8
Socket GS14	Socket Opamp	4	Socket GS14
B1	Rectifier	1	DIL
IC_C_1,IC_L_1,IC_H_1	Opamp	3	NE5532A
ICH7	Opamp	1	NE5534A
IC_M_1	Opamp	1	TL074P
IC_M_2,IC_M_4,IC_M_3	Compara-tor	3	LM339N
IC_OUT1	Bal Line Driver	1	THAT1646
COLOUR1	Connector	1	SAMTEC CON
	<b>BAG</b>	<b>11</b>	
RGB_LED1	LED	1	RGB_LED
LED_M_1-6, LED PAD+POL	LED	8	LED_GREEN
LED_M_7-10,LED_H CUT_L CUT_COL	LED	7	LED_YELLOW
LED_M_11-12,LED_48V	LED	3	LED_RED
	<b>BAG</b>	<b>12</b>	
X3	Connector	1	2514-straight
X4	Connector	1	2514-angled
Buscable	Cable	1	14 pol Buscable
LC1	Potential-meter	1	50K NLOG
HC1	Potential-meter	1	10K LIN
COLA1	Potential-meter	1	20k LIN
FADER1	Potential-meter	1	10k log
0dB_Trim1	Trimmer	1	10k Trim

<b>PART ON PCB</b>	<b>TYPE</b>	<b>COUNT</b>	<b>VALUE</b>
	<b>BAG</b>	<b>13</b>	
DI25	Spacer	4	DI25
M3 Screw	Screw	8	M3 Screw
m7	Nut	2	M7 NUT
m7 washer	Washer	2	M7 washer
M9	Nut	1	M9 NUT
M9 washer	Washer	1	M9 washer
M3 Nut	Nut	3	M3 Nut
distance spacer	Spacer	3	Distance spacer Frontpanel
	<b>BAG</b>	<b>14</b>	
LED_PCB	PCB	1	LED_PCB
Bracket_PCB	PCB	1	Bracket_PCB
	<b>BAG</b>	<b>15</b>	
Switch Caps	Switch Caps	6	Switch Caps
11mm knob	Knob	3	11mm knob
11mm blue cap	Colour Insert	2	11mm blue cap
11mm red cap	Colour Insert	1	11mm red cap
15mm 6,35 knob	Knob	1	15mm 6,35 knob
15mm 6mm dhshaft knob	Knob	1	15mm 6mm knob
15mm red cap	Colour Insert	1	15mm red cap



<b>4K-E01</b>			
<b>PART ON PCB</b>	<b>TYPE</b>	<b>COUNT</b>	<b>VALUE</b>
	<b>BAG</b>	<b>1</b>	
R10	Resistor	1	10k7
RPAD2	Resistor	1	169R
R7	Resistor	1	1M
R9	Resistor	1	5k1
R3,R8	Resistor	2	619R
	<b>BAG</b>	<b>2</b>	
R4,R6	Resistor	2	100k
R5,R11	Resistor	2	10k
RPAD1,RPAD3	Resistor	2	649R
RPAD4	Resistor	1	13k7
R2	Resistor	1	150K
	<b>BAG</b>	<b>3</b>	
RG_10	Resistor	1	499R
RG_1,RG_9	Resistor	2	715R
RG_4	Resistor	1	1k07
RG_5	Resistor	1	1k15
RG_8	Resistor	1	1k02
	<b>BAG</b>	<b>4</b>	
RG_6,RG_7	Resistor	2	1k27
RG_2	Resistor	1	953R
RG_3	Resistor	1	1k05
RG_11	Resistor	1	300R
RG_12	Resistor	1	13R
	<b>BAG</b>	<b>5</b>	
C5,C4,C11,C10	Ceramic 2,5mm	4	100nF
C6,C13	Kerko 2,5mm	2	22pF
C12,C1	Wima 5mm	2	100pF
C9,C8	Electrolytic	2	220u35V
C3,C7	Electrolytic	2	100u35V

<b>PART ON PCB</b>	<b>TYPE</b>	<b>COUNT</b>	<b>VALUE</b>
	<b>BAG</b>	<b>6</b>	
U\$2	Switch	1	GRAYHIL_SINGLE
	<b>BAG</b>	<b>7</b>	
T_1	Transformer	1	JT-115K_EPC
	<b>BAG</b>	<b>8</b>	
Frontpanel	Frontpanel	1	Frontpanel
PCB	PCB	1	PCB
	BAG	8	
Socket GS8	Socket Opamp	2	Socket GS8
IC_1,IC_2	Opamp	2	NE5534
Colour Insert	Colour Insert	1	15mm blue cap
	<b>BAG</b>	<b>9</b>	
Frontpanel	Frontpanel	1	Frontpanel
PCB	PCB	1	PCB