



EXT 51X

PCB layout for reference

This updated EXT 51X Series Extension is a complete set of PCB's, parts and components required to build an Extender for testing and calibrating 51X series modules. In addition you can use our EXT 51X Modul Adapter to get your voltages directly out of the Rack via 4mm Hirschmann connections. It's also possible to run the adapter without the extension and power your module with an external power supply.

Check the direction how the Module is Plugged in. We add to each Kit these small 51X Spacers. Add them to the Card Connector to connect always Standard 500 Modules and don't went wrong in the direction. Make Sure you solder wires to the 4mm Hirschmann connectors and to the PCB

We also designed 3D Print parts, to print your own case for that stereo module, required parts come with the case parts option. For the the M3 Inserts you use a solder iron at 250°C and press them softly in place. In this sheet you will find schematics, Overlays and Bill of Materials. Have Fun!

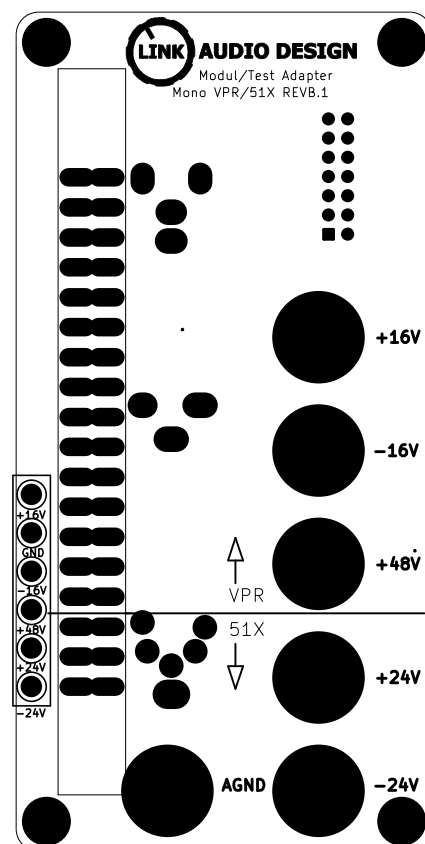

DISCLAIMER: Proceed at your own risk. I am not liable for any damage, harm or loss of any kind resulting from the assembly and/or use of this PCB set. Safety provisions should always be exercised whenever working with any electronics. The following instructions are guidelines only. I can make no guarantee of the accuracy of contents contained within this document.

Schematics

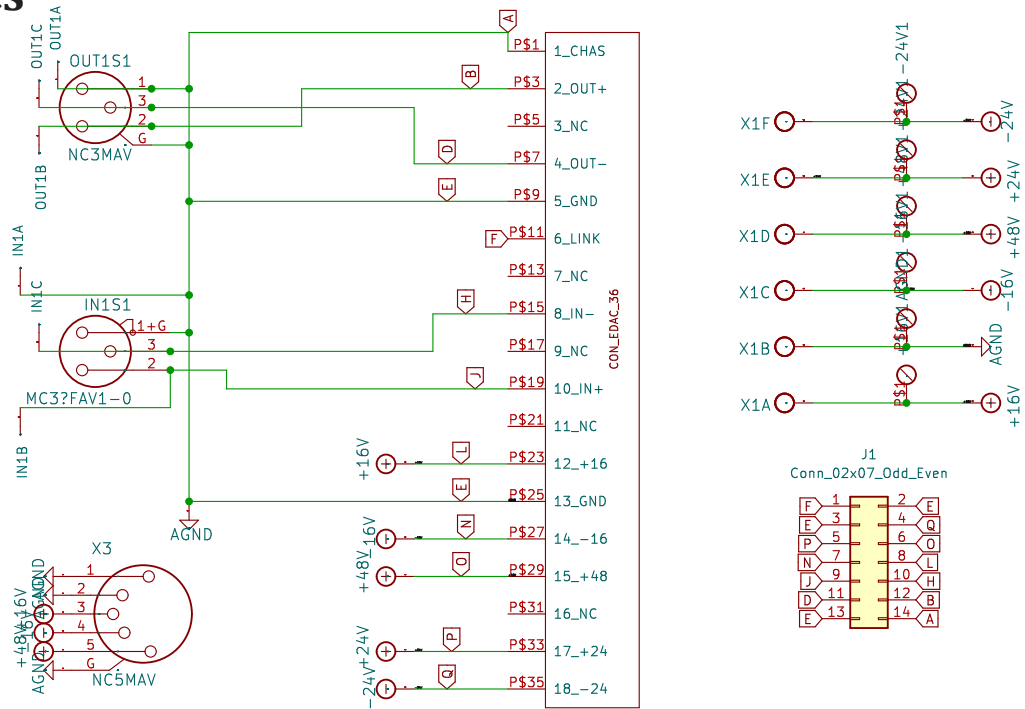

Bill of Materials (BOM)

1	PCB Set		1	Mainboard
2	PCB Set		1	EXTENDER Board
3	PCB Set		1	Backpanel
4	20mm Spacer		4	20mm Spacer
5	Screw M3		8	Screw M3
6	Modul Connection		1	36 PIN Connect
7	IN1,IN2		1	NC3 FAH
8	OUT1,OUT2		1	NC3 MAH
9	DC INPUT		1	NC5 MAH
10	+48V		1	4mm Yellow
11	-16V		1	4mm Blue
12	+16V		1	4mm Red
13	GND		1	4mm Black
14	-24V		1	4mm White
15	+24V		1	4mm Green
16	2x7 angled Connector for extension cable		2	GS 14W
17	extension cable		1	100 cm Cable
18	Cable for connect 4mm Connectors		1	10 cm Cable
19	Spacers for using 500 VPR Modules		1	51X Adapter
20	XLR Screws		6	XLR Screws
21	CASE PARTS		10	M3 Inlay
22	CASE PARTS		10	Inbus Screws
23	CASE PARTS		1	Front Panel
24	CASE PARTS		1	Back Panel

