

Leading-Edge Motorsport Technology Since 1990

Racecar engineering™

March 2014 • Vol24 No3 • www.racecar-engineering.com • UK £5.50 • US \$13.50



Design legend

John Barnard's remarkable career in the spotlight



Charge air cooling

Cranfield thesis on the revolutionary F1 powertrain



Corvette C7R

General Motors' GT muscle car makes racing debut

Formula 1 testing

Analysis of the new regulations as the 2014 cars break cover



Plus

Limitations of wind tunnel testing

Technical update from the Daytona 24 hours

All the news from the Autosport International Show



THE EVOLUTION IN **LIGHTWEIGHT FLUID HORSEPOWER™**

XRP® ProPLUS Race Hose™ and XRP® Race Crimp Hose Ends™

A full PTFE smooth-bore hose, manufactured using a patented process that creates convolutions only on the outside of the tube wall, where they belong for increased flexibility, not on the inside where they can impede flow. This smooth-bore race hose and crimp-on hose end system is sized to compete directly with convoluted hose on both inside diameter and weight while allowing for a tighter bend radius and greater flow per size. Ten sizes from -4 PLUS through -20. Additional "PLUS" sizes allow for even larger inside hose diameters as an option.

NEW XRP RACE CRIMP HOSE ENDS™

Black is "in" and it is our standard color; Blue and Super Nickel are options. Hundreds of styles are available. Bent tube fixed, double O-Ring sealed swivels and ORB ends. Reducers and expanders in both 37°JIC and Clamshell Quick Disconnects. Your choice of full hex or lightweight turned down swivel nuts.

CRIMP COLLARS Two styles allow XRP Race Crimp Hose Ends™ to be used on the ProPLUS Race Hose™, Stainless braided CPE race hose, XR-31 Black Nylon braided CPE hose and some convoluted PTFE hoses currently on the market. Black, Gold and Super Nickel.

ANTI-STATIC PTFE COMPATIBLE WITH ALL AUTOMOTIVE FLUIDS AND FUELS

A highly compressed, non-porous matrix that is resistant to fuel permeation and diffusion.

SMOOTH INTERNAL TUBE

For superior flow rates, minimum pressure drops AND ease of clean-out, not possible in convoluted hoses.

YOUR CHOICE OF OUTER BRAIDS

XS: Stainless Steel
XM: Lightweight XtraTemp Monofilament
XK: Aramid Fiber
XT: Tube only for inside fuel cells

EXTERNAL CONVOLUTIONS

Promotes hoop strength for vacuum resistance and supports tight bend flexibility.

LEARN MORE ABOUT

XRP® ProPLUS Race Hose™
and XRP® Race Crimp Hose Ends™
at www.xrp.com



Like us on
Facebook/XRPinC



Follow us on
Instagram #XRPracing

XRP, Inc. 5630 Imperial Hwy.
South Gate, CA 90280

Tel: 562.861.4765
Email: sales@xrp.com

In Europe JLS Motorsport
fax: 44 (0) 121 535 4833

Tel: 44 (0) 121 525 5800
Email: motorsport@lister.co.uk

XRP®
THE XTREME IN RACECAR PLUMBING

COVER STORY

- 8 **F1 testing**
The first look at the class of 2014 in Jerez has raised eyebrows - and teams clearly have a lot to work on

COLUMNS

- 5 **Ricardo Divila**
On how to separate the best drivers from the rest
- 7 **Mike Blanchet**
A change in philosophy is needed to avoid dull circuits

FEATURES

- 16 **Corvette C7R**
We run the rule over the latest in a winning lineage
- 22 **Juno LMP3**
The first carbon-fibre racer from this English constructor
- 24 **John Barnard**
A look back at the pioneering digital-age designer's career

TECHNICAL

- 31 **The Consultant**
A vibrant discussion on interconnected suspensions
- 35 **Databytes**
How wireless advances have helped engineers
- 39 **Aerobytes**
The final part of our series on a Formula Student entry
- 42 **What wind tunnels can't do**
Know the limits of off-track aero development
- 50 **Charge air cooling**
A Cranfield study into a theoretical design for F1 use
- 58 **Motion position sensor**
Measure hard to reach areas with Reventec's new solution
- 61 **Race preparation**
The firms dedicated to getting you ready to race
- 67 **Simulation**
How SoVa Motion have taken tyre testing to a new level
- 73 **Balance of Performance**
IMSA's headaches in merging Daytona Prototypes and P2

BUSINESS NEWS

- 76 **Trade show review round-up**
All the news and award-winners from Autosport International, plus dispatches from the relocated PRI
- 85 **Industry news**
UK Motorsport Valley rakes it in, Middle East F1 rights deal, Pirelli's new contract, plus the ZEOD ICE breaks cover
- 90 **Racecar people**
Alejandro Ajag on Formula E, Williams recruitment latest, plus the latest Race Moves and sponsorship deals
- 96 **Products**
New B-G Racing pit kit, plus gear from DEI, Apex and EOS
- 98 **Bump stop**



Subscribe to *Racecar Engineering* - find the best offers online
www.racecar-engineering.com

Contact us with your comments and views on [@RacecarEd](https://twitter.com/RacecarEd)
or on [Facebook.com/RacecarEngineering](https://www.facebook.com/RacecarEngineering)

QUALITY AND RELIABILITY



HIGHER FLOW RATES LESS FRICTION MORE POWER

With more than 40 years of experience manufacturing high performance racing valves, Supertech utilizes the finest material and design to make available the most durable, high performance racing valves on the market today. Supertech valves are forged, CNC machined, and hand polished for strength and reliability.

All Supertech parts are measured against the strictest tolerances in the industry and utilize finite element analysis, enabling us to provide a high performance product, without sacrificing durability. Regardless of your high performance needs, Supertech is the best choice for you if quality, durability and performance are vital to your needs.



3580 Charter Park Dr. San Jose, CA. 95136 USA (408) 448-2001

www.supertechperformance.com



The eyes have it

Much as engineers hate to admit it, great drivers can really make a team

Having worked with more than 190 drivers, among which were eight world champions - some successful, some average, some useless - one begins to see a trend in their characters and personalities. One has sometimes been scathing about them, but it is a love-hate relationship, and deep down we all acknowledge that most engineers, mechanics and team owners are frustrated racing drivers.

As a designer, one appreciates the fire within, the urge to win, but most of all what they can bring to the car one has designed and the team that is running it.

In musical terms, a technical director is a composite of composer and conductor, and if there are few Mozarts, Bachs and Beethovens, most of us can be a Rossini or at the worst Salieri, as just getting a car to the track is an achievement in itself.

Making it competitive is another step, and winning consistently depends on the virtuosity of your lead - in this case your driver - and the team around you will also respond to inspired leadership from your baton, but most of all to the team's appreciation of the driver.

'Drivers are just interchangeable lightbulbs - you plug them in and they do the job,' said Teddy Mayer. Maybe true at a certain level, but right at the top I agree with Harvey Postlethwaite: 'If I had to go out and spend a budget to go F1 motor racing, I would spend a great big chunk of it on getting the best possible driver,' he said. 'The day we put Jody Scheckter in a Wolf was the day the team went whoosh!'

Just as tyres are the fundamental interface of the car with the ground, drivers are what make machinery come alive - and the spectators, the ever-fickle populace, realise that, as

witnessed by the kudos of being World Drivers' Champion, the title of Constructors' World Champion is only prized by the teams themselves and the sponsors who pump money into it.

In the same musical terms, much as one can notice the different style of the fluid wailing guitar of Jimi Hendrix and the full-bodied mellow purity of Jeff Beck, the trademark wah-wah pedal on Eric Clapton's tone, or the oscillating fuzzbox of Keith Richards, drivers do have distinctive styles of driving, and will actually drive the design of the car, sometimes to the point of destroying their team-mates' reputation if their idiosyncratic style is different.

Some drivers want a front end that goes where they point it, while others need a solid rear end. As we do our vehicular dynamics, we can say what will be the quickest way around a track, but the fuzzy bit we miss is the feeling a car has, and how the driver responds to it.

Today, good simulators give this feedback, so maybe we have eliminated the uncertainty of design, but - again - a design ethos that can only flower if the simulation is correct surely has something wrong with it. The recent quote by Alonso that he was pleased with the progress the 2014 Ferrari had made 'when trying it on the simulator' is a milestone in paradigm changes. Welcome to the future. The slight caveat is that if there is no testing, where are the new drivers coming from? Should we look at gamers?

Engineering a car can be done from the prat perch, but one finds that it is much more enlightening to crouch by the car and look the driver in the eyes. The quick ones have the 'killer' eyes. Forging a relationship with the driver is also part of your composition, as he depends on you as much as you depend on him.

It is a strange condition, when you and the team entrust the fruits of your work to someone, then wait with bated breath and increased adrenaline for the time to be materialised on the monitor, willing it on to flash purple and beat the opposition. After everything your group has done, the driver is the one that can make it happen, he is the one that carries the responsibility, and he knows it.

Motor racing must surely be one of mankind's most frustrating



F3 driver Jann Mardenborough, having a thoroughly pleasant day

pastimes. More often than not, one of the many necessary elements falters. It is rewarding to have all the factors together and sometimes the driver can bring that extra something to the team that makes it climb over the wall of spear-carrying on to the peaks of winning.

And drivers can make a team. After languishing in the ranks of the also-rans for decades, the insertion of Schumacher into the cockpit of the red 'bórido' took away the team's excuses, putting the blame squarely on to the designers.

You are 100 per cent biodegradable, and so are drivers' reputations. There is a Buddhist saying: 'you cannot live on past applause.' The working lifetime of an engineer sees the parabolas of drivers' careers time and time again as they rise, are acknowledged and fade.

Young drivers can be fast, but like a poet that knows how to make a poem - they just don't yet know why. Win enough, or punch above their weight, and the probability is that they will find themselves in the best team.

The elements of probability weren't teased apart until 1837, when Siméon-Denis Poisson divided it into the dual concepts of statistical frequency (called 'chance') and subjective judgment (sometimes referred to as 'raison de croire'). In the same way, drivers' reputations are forged out of the results they obtain, which comes back to the equipment they have.

Cars today condition what a driver can do, so maybe only their team-mate can be used to give an objective yardstick.

Some stand out from the start of their careers, some blossom later, but they are not there just to compete, they are out there to win, driven by a need to assert themselves. This is who one wants in the car, no doubts that it will not be driven to the limit, and beyond. To be sure that when sent out for that one qualifying lap he will always bring home the bacon.

That said, I say that despite having always considered drivers to be normal persons with a very developed skill, ie driving racing cars, some - Fangio, Senna, Schumacher - are a step above others. Apart from those, and of course the rent-a-drivers, most drivers in F1 are of a very good level. Winning a world championship is a good indication of ability, but motor racing depends a lot on the equipment you use. Some very good drivers simply never had the machinery to justice to their talents.

Which leaves us with the defining characteristics of a winning driver: skill, perfection and testicular fortitude.

And those killer eyes.

Engineering a car can be done from the prat perch, but it's much more enlightening to crouch by the car and look the driver in the eyes



University of Bolton



Open Day Saturday 1st March

A Unique Educational Experience

Visit our Centre for Advanced Performance Engineering

UCAS 779L Automotive Performance Engineering BEng (Hons)

UCAS F4G5 Motorsport Technology BSc (Hons)

Open Day Sat 1st March

The **University of Bolton** and RLR Msport have joined forces to create a high performance motorsport engineering centre on campus, **giving students Le Mans LMP2 race team experience.**

This is a unique partnership - we have brought together first-class, on campus learning together with the best in practical motorsport experience.

Employability

We give our graduates the competitive edge in securing careers within the following industries, and many more in the UK and across the world.

- Motorsport & Trackside Telemetry
- Automotive & Mechanical Design
- Engine Performance Analysis
- Chassis Dynamics and Aerodynamics
- CNC, CAD CAM, CFD and FEA
- Specialist 3D Scanning Equipment.



Study on Campus and on the track!



Contact us for more information

Email opendays@bolton.ac.uk or call **01204 903942** or **01204 903806**



Going round in circles

Time for more racing spectacle, and to get away from bland, forgiving circuit design

Are you, like me, left shaking your head in disbelief when a new F1 circuit is first announced and all the comments and praise refer primarily to the infrastructure and the facilities, rather than the layout and challenge of the track itself? While waxing lyrical about the showpiece it represents, it seems that many people have lost the plot, which is that above all a circuit is for racing, not just a statement of a country's prowess and seemingly designed mainly for the maximum convenience of those involved.

Even more shaking of head ensues when, so often, those familiar but dreaded words 'difficult to overtake' are heard. Along with safety and a contemporary standard of facilities and presentation the most obvious requirements for a new circuit should surely be:

- **Interesting track layout, presenting a challenge for drivers and their engineers**
- **Overtaking points for creating and maintaining spectator and TV audience excitement**

Therefore 'difficult to overtake' as reported above means, in my book, 'not fit for purpose'.

There is absolutely no reason why a newly-conceived and built track should not incorporate reasonable passing opportunities, because enough examples exist of how this can be achieved. Just as, quite rightly, no track can be granted a licence without it complying with the host of stipulations making it suitable for F1, the incorporation of at least a couple of proven overtaking zones in its layout should, without doubt, be included as well.

Ways of increasing the spectacle of motor racing by

providing more overtaking potential have been attempted almost exclusively by technical measures centred on the competing cars themselves - reduction in wing sizes, DRS, deliberately-induced tyre degradation etc - but have been only partially successful. As well as being very expensive to develop, some of the steps taken have had adverse effects in other areas, recent tyre debacles being one glaring example.

I advocate that it's time that this emphasis on always changing the cars is consigned to the bin. Surely the cost of designing and laying the new track itself is but a small part of the total investment in today's mind-boggling structures? It need not be much - if at all - more expensive than the anodyne configurations with their ridiculous, skill-sapping acres of run-off area which are increasingly being foisted on us.

Hermann Tilke and his design group have been responsible for virtually all new F1 circuit design for the last dozen years or so, and according to a 2011 Guardian newspaper piece: 'Tilke focuses on conceiving dramatic architecture that reflects the host country, like Sepang's lotus-leaf grandstands in Malaysia, while also aiming for spectator comfort and clear viewing. He builds corners that promise a fast and interesting race but avoid pulling the field apart.'

I think the emphasis as expressed and the order of them make my point exactly. What's more, it cannot be good to have a single entity producing one circuit after another. So, through Sepang, Bahrain, Shanghai, Istanbul, Valencia, Marina Bay, Yas Marina, Buddh and Austin

(the latter admittedly one of the better ones) the time pressures involved in conceiving all these must mean that a large amount of 'cut-and-paste' has taken place. With the best will in the world, it is inevitable that a degree of uniformity coupled with lack of character will develop. Instead of continuing down this road, let's have some imagination in track design and layout!

Off-cambers, banked corners, asymmetric grip levels into hairpins, blind apexes, more

become easier to drive near the limit - watch Senna in qualifying around Monaco in a 1980s McLaren-Honda and then watch Vettel in his Red Bull-Renault if you're not convinced - so make the track more difficult. While welcoming without reservation the fantastic progress made in driver safety over the past 20 years, the acres of concrete run-off increasingly evident in modern circuit design surely dumb-down the expression of calculated bravery that should be

a factor in a racing driver's make-up. Take away such blatant 'get-out-of-jail' expanses and the corner becomes far more of a challenge. The likelihood of hitting something hard at speed definitely has an effect on the throttle foot.

Being willing to take on this risk is the factor that makes car and motorbike racing and other high-risk sports different, giving that

'edge' and that unique adrenaline-rush. How many sharp intakes of breath were there from everyone watching when Alonso and Webber went sidepod-to-sidepod into and through Eau Rouge at Spa in 2011? The commitment was awe-inspiring because the risk was evident at such velocity, with the Armco waiting if contact had been made. Balls-out racing at its best, nothing to do with tactical play and technical gizmos! Motor racing needs this to better define good drivers from great drivers, winners from just points-scorers, and for the appreciation of the spectators, commentators and viewers.

We need much more of this to improve the spectacle, and to draw in the major sponsors that racing is currently crying out for. The circuits should deliver, not just the cars.



Yas Marina Circuit in Abu Dhabi, one of many recent arrivals to the calendar created by Hermann Tilke

The acres of concrete run-off increasingly evident in modern circuit design surely dumb down the bravery that should be in a driver's make-up

Into the sunlight

The new 2014 regulations have produced innovation and controversy, and made for an interesting first test in Jerez in January

BY SAM COLLINS

Mercedes was one of the first out of the blocks at the first test in Jerez. Most teams attended the test. Only Lotus announced that it would miss it



As was made abundantly clear at the first official test in Jerez, in engineering terms, Formula 1 is facing what may be its toughest ever year. The arrival of new twin hybrid power units with a 1.6-litre direct injection turbocharged engine at their core, coupled with a completely rewritten rulebook, has changed the game significantly. 'It's been a massive job to accommodate all the changes to the power unit - it's the biggest change I've witnessed in the sport since I started in 1990,' says Force India technical director Andy Green. 'On top of that, if you add the development that comes with it during the season, it's going to take some managing.'

Despite this, the most discussed rule change is one of the more minor details in the technical regulations governing the car's dimensions. For 2014, the cars have to be fitted with a nose tip which is no more than 185mm high, a substantial reduction over the high noses of recent years.

The FIA had hoped that this would bring back the low nose look of the 1990s and improve safety, but the result is rather more unsightly, with many teams having rather prominent front sections. The chassis around the driver's legs and feet is now also significantly lower, due to a regulated drop in maximum height at the front bulkhead, introduced for the same reason.

These 'finger' or 'brewer's droop' noses have been universally criticised, even by those who designed them. 'It is not a strictly technical matter, as we all design a car that gives the best performance, regardless of the styling,' says Red Bull's Adrian Newey. 'But I think that the shape of the cars is all part of the excitement of Formula 1,

and it is a shame that they are unattractive and that the rules have forced ugly solutions.'

The noses are a crucial part of the car's structural design, as they also form the front impact structures, but despite the wide range of shapes on display - from the rather more elegant looking Mercedes and McLaren designs to the extreme twin structure Lotus (see sidebar, p10) - it seems that this is not an area of great aerodynamic importance.

'There is a different nose on every car, and there is not too much similarity between any of them,' says Ferrari technical director James Allison. 'The nose rules allow quite a lot of geometrical freedom, so of course you explore that. There are such big variations between the cars because it is not that much of a sensitive area. There are lots of solutions that work.'

SAFETY CONCERNS

It seems fairly clear that the rule-makers at the FIA had not realised that the nose regulations would make the cars quite so ugly, and according to some there have been some other unintended consequences. The nose tips now sit lower than the rear crash structure found on all of the cars, and Newey among others has raised fears that this could lead to cars being lifted up by one another.

'The regulation on the noses was introduced following some research by the FIA, which suggests that it reduces the chances of the cars being launched, like the accident Mark Webber had at Valencia a few years ago,' says Newey. 'I must admit I am concerned that the opposite may happen and that cars will "submarine". If the

"It is a shame that the cars are unattractive and that the rules have forced ugly solutions"

PHOTOGRAPHY BY LAT, XPB AND LAWRENCE BUTCHER





THE LOTUS NOSE

When the Lotus E22 was revealed in the form of a low resolution, low detail rendering on Twitter it took many by surprise. While most teams have a single, low, 'anatomical' nose the Lotus appears to have a pair of tusks. This approach is not unprecedented - the Audi R15+ LMP1 had twin front impact structures. This was a good way for the team to get the aerodynamic effect it wanted, as well as meeting the crash test regulations. However, the 2014 Formula 1 technical regulations state in 15.4.3 that:

'An impact absorbing structure must be fitted in front of the survival cell. This structure need not be an integral part of the survival cell but must be solidly attached to it. No part of this structure may lie more than 525mm above the reference plane. It must have a single external cross section, in

horizontal projection, of more than 9000mm² at a point 50mm behind its forward-most point. Furthermore:

- a) 'No part of this cross-section may lie more than 250mm or less than 135mm above the reference plane.'
- b) 'The centre of area of this section must be no more than 185mm above the reference plane and no less than 750mm forward of the front wheel centre line.'

But what it does not say is that a 'single' impact absorbing structure must be fitted in front of the survival cell. In other words, multiple structures could be used. This appears to be a loophole in the rules that Lotus has exploited, and it is possible that the car has a small piece linking the two structures which would make it a single structure.

At the launch of the Toro Rosso STR9, James Key suggested that questions would

be asked of the FIA as to the legality of the concept: 'The Lotus nose needs clarification, but it's a very clever idea. The question really is, is it within the spirit of the rules?'

'We looked at it early on, when the car was quite a bit less mature than now, and in theory it was working well. But in reality we felt it had too many drawbacks, so we didn't pursue it. We kind of understand where they've gone with it. It could be worth a revisit at some point when things have calmed down a bit.'

'I don't think it's illegal, it's just whether it's in the spirit of the regs. Our interpretation of a similar idea was with a slightly different front of the nose, to the point where we were happy that it would be accepted within the spirit of the regs. I'm not saying the Lotus one isn't, but it's probably the most extreme out there.'

The new regulations based around the nose of the Formula 1 cars have been controversial and have led to a raft of different designs. The regulations themselves have come under scrutiny as the noses are so low that designers fear that they will 'submarine' under cars, and launch them

following car hits the back of the one in front square on, it will go underneath it and the driver will end up with the rear crash structure in his face - which is a much worse scenario.

'There are some accidents we have seen over the years that make you wonder if a low nose would have made it worse, not better. Like all of these things, it might be worse in some scenarios, but it may help in others. I don't think the low noses will stop cars launching in all scenarios either. If the following car hits the rotating rear wheel, it will get launched regardless, like Patrese and Berger at Estoril in 1992 or the two Minardis at Monza the following season - they were low nose cars that got completely launched. For me the low noses have introduced more dangers than they have cured.'

Beneath the nose sits a region which is less obviously different, but far more important in aerodynamic terms. The rule changes here are fairly simple, limited to a slightly

The Lotus E22 features 'tusks' that some have called into question





stiffer front splitter (tea tray) and a narrower front wing.

'The front wing in the centre is very similar in its philosophy, as we still have the FIA central section and the vortex that comes from it,' says Toro Rosso technical director James Key. 'But the endplates are now right in the centre of the tyre. If you look at 2008, the endplates channelled airflow inside the front wheels - inwash - and from 2009 to 2013 it became clear that as much outwash as possible was good. Now it's right in the middle and the question we are all asking is: do you go one way, the other, or do you try to encourage both? It's very complicated, and these areas are very much up for development - we will see a lot of change through the year.

'The whole area around the brake duct is also substantially different in aerodynamic terms,

even though it may not look like it. Yes, losing the beam wing at the rear of the car is significant, but fundamentally it's just a loss of load. The front wing and lower chassis, however, is surprisingly different.'

The airflow in that area in the car feeds the cooling ducts in the sidepods, and cooling is one of the biggest challenges with the new power units. Some claim that they require as much as 125 per cent more cooling than the 2.4-litre V8s used up until 2013.

'Cooling has been the biggest challenge,' says Green. 'Most of last summer was taken up trying to understand the cooling requirements of the power unit, and how best to optimise it in the chassis. There's a lot more to cool and you are weighing up the performance of the power unit vs the performance of the chassis and aerodynamics, and trying

to hit the optimum on each one of them. We've had to develop a completely new toolset to examine, analyse and optimise it.'

It is apparent when looking at the cars that the three different power units have very different cooling demands. While the Renault-engined cars have notably more cooling than the 2013 designs from the same teams - apart from Red Bull, which at the time of writing had only run for three successive laps in testing - all of them are accompanied by the acrid smell of burning carbon fibre and electrical insulation.

'You have to make up for the amount of additional cooling devices that you have had to put on the car in some way,' says Key. 'It's hard to compare to 2013 because the heat rejection from the engine is obviously less, as it is much smaller. But you have

the charge cooling which is an added complication, and then you have the turbo, which adds heat to the mix, and then with the ERS cooling there is a significant increase. While there is not a huge amount more demand on air to the coolers, you have a lot more cooling circuits.'

Meanwhile, the Mercedes teams also seem to have somewhat increased cooling, but the Ferrari cars appear to have less than 2013 designs.

'Our engine department have been aggressive and bent over backwards on the chassis side to produce an engine that can be packaged tightly and cooled with radiators that are not too big,' says Allison. 'Our car has quite a neat bodywork package and the radiators are quite small. The engines are incredibly busy compared to the V8s, and the Ferrari has been rather

"Cooling has been the biggest challenge. Most of last summer was taken up trying to understand the cooling requirements of the power unit"

Packaging the power unit is a challenge, not least due to its high cooling demands and high weight. The units are proving to be unreliable in testing, leaving many teams struggling to even get their cars to run on track

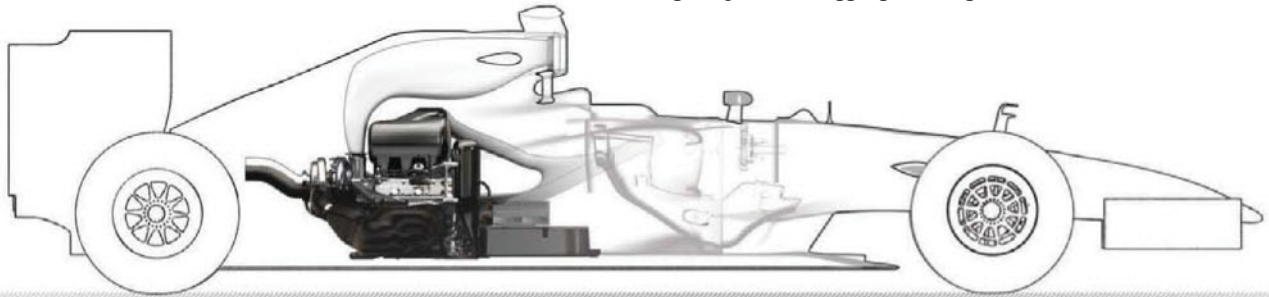

exquisitely packaged. It's very neat and small.'

While the thermal management of the power units is a challenge, the teams seem to feel that the overall challenges of the layout are more difficult to overcome, especially in terms of overall vehicle weight. Force India in particular has been unable to get down to the 690kg weight limit. This is largely because the power units on their own are significantly heavier than the old V8s, and when the additional subsystems required to operate them are added - such as the aforementioned cooling circuits - the weight goes up even more.

'Getting to the weight limit is a big challenge, and we have had to work really hard to get it under control,' says Key. 'I think we should be OK with our car. The problem is that the regulations have evolved a lot over the last 12 months, but the weight was

agreed early on. If we re-did it all again, we would probably look at doing something different in terms of rules, and it will probably change in 2015. Once you have managed to get to the weight limit, only then can you start to look at CofG height and weight distribution. It's proved quite tough to hit the weight limit.'

The technical regulations also restrict the front-to-rear weight distribution, and the weight applied to the front and rear wheels must not be less than 314kg and 369kg respectively. 'You don't really want the fixed weight distribution regulation at a time like this, but it is there

and you have to respect it,' adds Key. 'You have to design around the window and make sure you are in it. You do not just want to be at one end of it either, so you may tweak your front wheel centre line a bit and look at all of the masses in the car and move it about as you develop. If we didn't have that rule, it would all be a bit different.'

But it is not just housing the weight within the car that is giving the designers headaches - it is also the issue of packaging the power unit components in a way that allows them to operate correctly. This is especially true in terms of the battery, which

must by regulation be mounted in the monocoque underneath the fuel cell. With a 35 per cent reduction in fuel consumption year on year, the large battery pack takes up much of the volume left from the reduced tank size. 'It has been bloody complicated for us to get it in the car,' says Key. 'The battery and fuel cell determine the chassis length, but you make up for that with the smaller engine size. The thing that has more impact overall is the bell housing and gearbox casing being designed to accept turbos. That's more influential on the wheelbase, and for us we are marginally longer than in 2013.'

The actual internal combustion layout creates some packaging issues for the teams too, knocking on to other areas of the car's design. 'The turbo is mounted very low on the rear of the engine,' says Key. 'It means that your rear suspension is really tightly

"Getting to the weight limit is a big challenge, and we have had to work really hard to get under it. It's proved quite tough"

LOW BATTERY

The power unit energy store has become something of a focus for many teams, not least Red Bull Racing. Chief technical officer Adrian Newey is unhappy that he has been forced to mount the battery pack in front of the engine, rather than behind it as he did with all of his previous hybrid F1 cars.

'It's a shame that we chose to have the batteries and KERS components around the bell housing on our previous cars, and could not carry that over,' he says. 'It allowed us to put the weight at the rear of the car and get the layout we wanted in terms of engine position and wheelbase. This has now been removed and

the battery now has to be in front of the engine and under the fuel tank. I think that is a shame, and the only freedom beyond that is whether you carry the KERS control unit in the fuel tank as well or under the radiator ducts.

'It was done on safety grounds, but I'm not sure how putting a battery under the fuel tank is safer than putting it under the engine. Putting the battery under the fuel tank is uncharted territory. Remember, Boeing had an absolute nightmare with the batteries on the Dreamliner - it grounded the planes. These batteries can suffer thermal runaway through impacts, and other causes that are difficult to

predict. Once they go into that, then it is very difficult to control that fire - frankly it's a case of putting it in the pit lane and watching it burn.

'I don't think it is a driver safety concern, but overall it is a danger. The voltages are also very high and large DC voltages are very dangerous. So for the whole pit lane, the safety aspect is a very big challenge with these cars.

'Another big challenge here is the supply chain. As soon as you work with outside manufacturers, battery suppliers and electric motor manufacturers, you realise that they don't work to motorsport lead times. They don't work in days and weeks, they work in months

and years, so it's not a problem you can get out of quickly.'

Because of the complexity of the power units and the reliability concerns, it seems certain that at least the early portion of the coming season will be dominated by the power units. 'In those early races it will be an engine formula, because those engines are relatively under-developed compared to what we have been used to,' adds Newey. 'But as the formula evolves and the engine manufacturers iron out the wrinkles, it will go back to being a combination of chassis and engine.'

'I can't see that there are any favourites this year. It's so new and so open that all bets are off.'

SHX Synthetic Shock Fluid

Driven SHX Shock Fluid utilizes next generation synthetic oil technology to provide consistent, fade-free dampening performance. This unique, competition proven formulation utilizes a proprietary additive package to reduce seal drag, improve air release during fluid handling and maintain viscosity under high temperatures and high shear forces. SHX outperforms conventional formulations and delivers consistent dampening in demanding applications like off-road trucks, motorcycles, rally cars and asphalt race cars.

VISCOSITY BREAKDOWN

% Viscosity Loss In KRL Shear Test

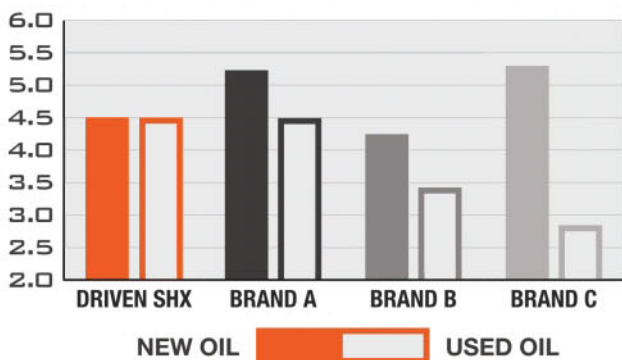

Driven SHX does not lose viscosity even after repeated heat and shearing cycles.

BORN FROM JOE GIBBS RACING
DRIVEN
 DRIVEN TO WIN **RACING OIL®**



Part Number 50040

www.DrivenRacingOil.com + 1-866-611-1820
 UK & Europe: +44 929 551557



The cooling system on the cars is proving to be a major packaging issue. Here on the Caterham CT05, two heat exchangers are visible, as is the lower side impact structure

TURBO SAFETY QUESTIONS

It has emerged that Ferrari may have to change the design of the turbo housing on the Ferrari 059/3 power unit, after a query over its compliance with the technical regulations was raised. The rule in question was 5.18.5, a late addition to the 2014 Formula 1 technical regulations, which states:

'Measures must be taken to ensure that in the event of failure of the turbine wheel, any resulting significant debris is contained within the car.'

Two of the three engine manufacturers have apparently

taken one approach, while Ferrari feels that it has met the regulation via a different method. Some reports have stated that Renault is set to complain about the design, but Renault Sport's Rob White claims this is not the case. 'I don't know anything about the Ferrari, so I couldn't be unhappy about it even if I wanted to be,' he says.

However, White admits that he is aware of the situation. 'There is a technical regulation that requires us to contain the debris in the event of a turbine wheel failure, and in addition there was a technical directive

packaged in there now. You have to go around this large lump of turbo, and that means we have to use some kind of bell housing, not a one-piece gearbox casing.'

Once the power unit is actually installed, the teams then have to get them to actually run. And as was made very clear at the first pre-season test in Jerez, this is far from an easy task. 'The biggest challenge of these cars is the electrical side,' adds Newey. 'It's hugely complicated, and crosses several disciplines. When you look at hybrid production cars, they have years of development before they hit the market. They are not really designed to be taken apart - they are almost sealed for life. The F1 environment is very different to that. Unlike previous years, with a KERS problem you could carry on. Now if you have one, it means you have to

park it at the side of the road.' Indeed, battery problems saw the Renault-powered cars all sidelined for a significant amount of time at the first test.

One of the reasons for this could be related to electromagnetic interference created by the high voltage system on the car. 'The important thing is to recognise that everywhere there is electricity, there is the possibility of interference between one current source and another,' says Rob White, deputy managing director (technical) of Renault Sport. 'The physics of it is quite simple, and the electromagnetic interference is most common where there are big currents that change rapidly.'

'The currents in and out of the MGUs are big and change rapidly. In the power electronics to control the MGUs, there are high frequency switching circuits, and

"Electromagnetic interference is most common where there are big currents that change rapidly"

published on the subject regarding correspondence between Charlie Whiting and Ferrari, but there was nothing in it about what Ferrari was or wasn't doing, so I don't know what it is.

'For us it's a matter of both technical regulation compliance and assuring the safety of the turbo in operation.'

Racecar understands that while Renault and Mercedes interpreted 5.18.5 as meaning that the turbocharger needs an additional ballistic cover (which weighs around 3kg), Ferrari has not. Instead it has designed the turbine housing in such a way that if the turbine wheel fails, the turbo housing itself contains any debris.

While not a breach of the regulations, it is thought that not everyone in the F1 engine community is convinced about this approach, and there are some that feel that the minimum weight of the cars needs to be raised by around 4kg to allow for the installation of ballistic covers.

Ferrari apparently is not keen on this.

the switching action from one polarity to the other can create the conditions for induced electrical currents. When you change the current rapidly in a wire, the wire next to it will see a change in magnetic flux and a current induced in it. If you have a big power cable next to a small signal wire, the induced noise can be the equal or bigger to the signal it is supposed to transmit, which will cause trouble for the whole thing. The sensors by their nature are sensitive, low voltage, low current devices, and any sensor or sensor wire next to a big, rapidly changing current source will be at risk of sending a false signal.

'It's a lot about the harnessing and shielding - it's something that has to be resolved as part of the commissioning of the car. It's a bit a case of pulling yourself up by the bootstraps - if the signal going into the control system is not clean then the control system cannot respond correctly.'

Testing was continuing in Jerez as this month's *Racecar* went to press. But it's clear that the teams have plenty to work on during the next two tests ahead of the 2014 season opener in Australia.



Renault's RS34 engine is fitted with a ballistic cover around the turbocharger when installed in a car, the Ferrari engine is not



JACOBS

 is a full service supplier to the Motorsport Community.

We provide engineering, construction, operations, and maintenance services for the motorsport community's most complex testing, research, and development facilities. To date, we have developed facilities for motorsport testing applications in Europe, Asia, and North America. Our wind tunnel experience spans the full spectrum of test section configurations: solid wall, open jet, slotted wall, and adaptive wall.

The latest release of our automated test measurement and control software, Test SLATE, offers a proven solution for integrating diverse hardware and subsystems, managing test configurations, and transforming test data into meaningful results.

We offer unique consulting services ranging from test planning to high powered computer simulation. We provide aerodynamic/flow analysis, stress and thermal analysis, acoustic analysis, and more to motorsport teams.

Please contact us to learn how we can support you!

JACOBS

Jacobs Technology Inc.
600 William Northern Blvd.
Tullahoma, TN 37388 USA
Phone: +1 931.455.6400
Fax: +1 931.393.6211
www.jacobs.com
www.testslate.com

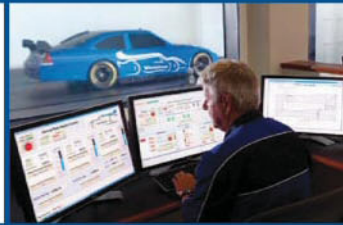
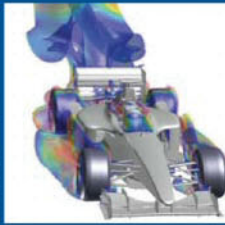

THE NEW EVOLUTION IN TE'S MOTORSPORT MICRO CONNECTORS

DEUTSCH AS Micro Xtra^{LITE} HE Connector

Ultra lightweight

- Compact size 2 shell
- No need for backshells for boot termination
- 6 x AWG24 contacts

Fast, easy installation

- Suitable for blind mating
- Positive locking coupling mechanism
- 6 keyway orientations



TAKE THE LEAD WITH THE DEUTSCH AS MICRO XTRA^{LITE} HE CONNECTOR WITH 6 CONTACTS

TE Connectivity (TE) introduces its DEUTSCH AS Micro XtraLite HE connector - one of the market's smallest diameter, lightest AS connectors for when space is at its most restrictive. Able to complement the ASX-3 and -5 options, this high performance interconnect helps to give you the edge in an environment where even the smallest component can be a true game changer.

Learn more at www.te.com/deutsch



DEUTSCH

Stingray's big brother

Corvette Racing used the Daytona 24 hours to debut the lighter and stiffer follow-up to the award-winning C6R

BY ANDREW COTTON



"They started with an aluminium chassis. It is 90lbs lighter, and 40 per cent stiffer. It's both lighter and way stronger"

Just about every new car that is launched emerges with fanfares boasting the words 'lighter', 'stiffer' or 'efficient', but in the case of Corvette's new C7R - which debuted at the Daytona 24 hours at the end of January - the

new chassis design has led to renewed optimism in the camp.

Designed and built by Pratt & Miller Racing, with close links to the production C7 Stingray, the car is the latest in a line of cars that has delivered nine Manufacturers' and Teams'

titles, seven wins at Le Mans from 10 starts, and eight drivers' championships in the categories in which it has run. The drivers say that the car is even better than the C6R, and were able to monitor the difference as soon as they jumped behind the wheel.

'What they have done is incorporate high pressure castings in the critical bends rather than hydroform rail,' says programme manager Doug

Fehan. 'Then they bond the hydroform rail to the high-pressure casting. It is lighter and way stronger. They started with an aluminium chassis. It is 90lbs lighter, and 40 per cent stiffer.'

'The beauty of hydroforming is that you take a tube, you bend it into a shape, insert it into a dye, plug the end of it and then load it with water pressure that expands the tube into the shape of the dye. That is how the frame rail was made. At the time, the chassis was the largest hydroform rail in the world. Rather than forming a bend, it maintained uniform thickness because you were blowing it up. You didn't have thin spots, thick spots, heavy



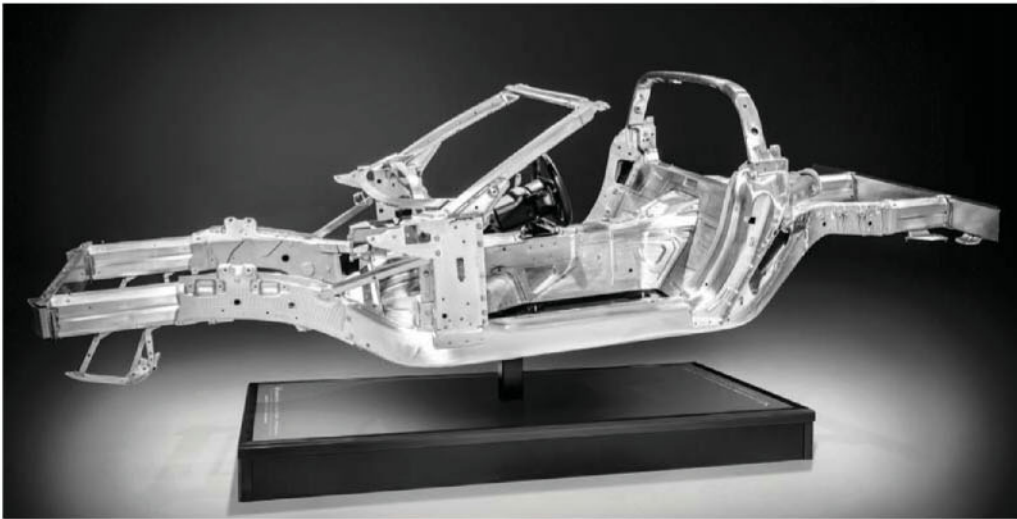

The aluminium frame structure of the Stingray, with 'greater torsional rigidity to improve ride and handling'

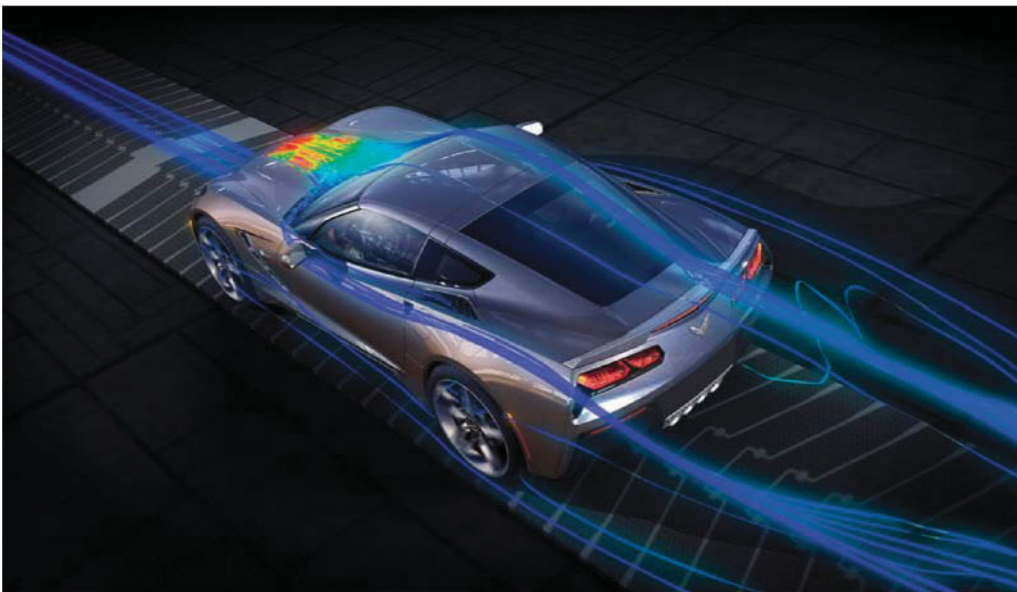

The production Stingray features a 6.2-litre V8 engine, while the C7R has the 5.5-litre which ran in the C6R



The C7R features a new cradle at the front and the rear for the engine and the gearbox. They are more robust

spots or weak spots, and the strength is incredible.

'When you want to address the high stress areas, the bends, the team said that there was new technology in this high pressure casting which is a super-thin wall that can be webbed. And it is amazing stuff. Each one of those bends is a high pressure casting. Then the rocker rail is still the hydroform rail - it is just welded to that upright. Each of these critical areas has the high pressure casting in it. That is where the weight is saved, and the increase in strength occurred. When the drivers got in they recognised it straight away.'

Drivers reported that the ride over the kerbs was markedly improved over the C6R following back-to-back testing. There were problems in qualifying at Daytona associated with a new car, but race pace was much better. The team targeted a 1-1.5 per cent increase in overall performance compared to the C6R.

POWER SUPPLY

The production Stingray has a 6.2-litre V8 engine and features variable valve timing (VVT) and direct injection. Working to reduce the capacity and take away the VVT technology was deemed to be too time consuming, too expensive and something that would raise the cost of the customer engine beyond acceptable limits, and so the team successfully sought to have the 5.5-litre engine of the C6R accepted into the new car, although it is upgraded to have direct injection.

'The new technology on this engine - aside from direct injection - is the variable valve timing, which is an amazing performance advantage,' says Fehan. 'It is not allowed in our series, so when you equated the cost of taking a brand new engine, developing it in a 5.5-litre configuration, and the elimination of VVT, you had a huge escalation in costs for no increase in performance. You're spending money and wasting time for essentially what we have here.'

'And, by the way, the sanctioning body is fully familiar and comfortable with this powerplant, and should any additional competitors want to come along and use it, we have this engine extended to almost 60 hours of running at about

\$120,000 initial cost, including DI, which is something that they implored the manufacturers to do, but no one paid any attention to it but us. There was no sense in rebuilding and retuning this thing, and that was the philosophy on both sides of the pond. This is an identical C6 engine, with the exception of the added DI.'

The team already had experience running direct injection on its GT1 in 2009. The production engine already had a DI port and so it was an easy introduction into the race unit.

There is a time-worn mantra at GM racing that a better racecar leads to a better road car, and that a better road car in turn leads to a better racecar. In the case of the C7R, the correlation between production and race models is clear. The front splitter, the side skirts and the air intakes are clearly taken from the road car and developed for racing, while the racecar influence on airflow through the production car has led to a tilted front radiator and air extracted through the engine cover.

'When you look at the cooling ahead of the rear wheels, it is the same on both cars,' says Fehan. The intake in the racecar splits the air and directs half towards cooling the rear brakes, and half towards the cooling of the differential.

'The rules control the bottom of the car so there is nothing different there. The production car is two inches wider at the front and three inches wider at the rear than the standard production Stingray, but in doing so, it gives them a wider area to take the air out. That is something that we learned in the wind tunnel and CFD and that works with the side skirts.'

The rear wing is wider than the C6R, and the team found that airflow to the wing is disturbed by the intakes behind the doors that feed air to the diff on the production car. The racecar therefore has lost the intakes, and has a new lip on the rear deck, replacing the full wing on the production car.

'When we add the rear wing, the air intake disturbs the air over it,' says Fehan. 'We run a different spoiler because it is a drag issue, so we have a waiver for it.'

Packaging under the skin has been improved following

A NEW SET OF EYES FOR DRIVERS

At the Sebring 12 hours in 2013, the Corvette team revealed a new device that is capable of informing the drivers of a car that is closing, at what rate it is closing, and which side the faster car will pass.

The system runs on a custom Linux machine with an Intel Core i3 CPU and uses a rear-facing radar sensor that is capable of tracking up to 32 objects while working in tandem with the camera. Different colours and symbols are displayed on the rear view screen, which allows the driver to easily see racecars that are behind, how close they are, their closing speeds, and even the approaching vehicle's racing class.

It was developed in conjunction with the drivers, and the team admits that it still needs refinement. Driver Oliver Gavin admitted that there are so many flashing lights in the cockpit that the driver learns to tune out many of them, but that this system is one of the most useful.

'There have been times that we have been very close to an LMP car and not been sure exactly where it is,' says Gavin. 'This system allows us to look very quickly at a screen and see exactly where it has gone, as it will be in our blind spot. You can tell on the screen people gaining on you. In the rain and at night, you have lights behind you and you don't know how far back they are, so this can give you an idea, and help you to work out if they are going to get you before the next corner.'

'There are lots of different systems, and it does get to be an overload, but it is good. It needs refining, but it works for us, and I think you will see a lot of teams going in this direction. It keeps us safer on the track particularly at a place like Le Mans which is so big that you cannot get enough spotters, cameras and so on. For that reason I think it allows the driver to be a little more self-sufficient.'

'It works on the screen but we are talking about how it will communicate with us. We're talking about having a buzzer in the helmet to work



The new Corvette system features a Bosch radar sensor that can track up to 32 objects while working in tandem with a camera

with the lights, and we will keep developing it.'

The system was inspired by the accidents that hit the Audi team at Le Mans in 2011, which were clearly directly caused by a lack of visibility. Allan McNish came from two cars behind and was hit by a Ferrari, which was unaware that he was there, while Mike Rockenfeller flashed another Ferrari at night. One of the criticisms of the Audi light system was that it was so bright, there was no depth of field, and so the driver did not know how far back, or how close, the Audi R18 was.

'When we watched the Audi incidents that occurred we just thought there might be a better way,' said programme manager Doug Fehan. 'We were fascinated by developments in the industry that lent themselves to developing something that has not been developed before. The aviation industry has used this technology forever, and if you look at the advancements in GPS and things like that, we said, "wouldn't it be great if we had a screen and the guy could see what was going on around him?"'

'What was really important was identifying the speed of the cars around him. We did a couple of runs at that several years ago, and it was something

of a success. So three years ago we dedicated ourselves to finding something that could track multiple cars, allow you to determine speed differential, would allow you to determine positioning right or left, and closing distance so that the drivers at a glance can see exactly what is going on. It can discriminate cars that are closing on you, that you are pulling away from and those that are travelling at the same speed.

'It was designed by Pratt & Miller. It uses a Bosch base radar and we write all the algorithms around that sensor that the driver sees. We did some testing with it, and the first application was at Sebring.'

'We worked with the drivers to accomplish what we needed to accomplish without the drivers getting distracted. It is another set of eyes. With the rear view camera you can see what is coming up and they were accustomed to using that, and this just gives more data with that same glance. You programme your brain to see that. If you see something green, you don't need to worry. If it is yellow you see where you are on the racetrack and if it is red, you know you are going to get passed, and which side. You can adjust to it very quickly, and become dependent on it.'

“The philosophy of the suspension is carried over from the C6R, but aside from the engine and gearbox, there aren’t any common parts”

the change to the chassis and the weight saving that came with it. The team was able to design a new cradle for the engine and at the rear of the car that is stronger, and slightly heavier than its predecessor.

‘The philosophy of the suspension is carried over from the C6R, the mounting points are from the C6R, and they all have a little bit of a different construction and configuration, both in weight and in terms of performance,’ says Fehan. ‘There are changes in geometry at both the front and rear. The

gearbox is essentially a carry over gearbox, although we have worked with Xtrac in developing pneumatically controlled adjustments to reduce the amount of time necessary to make changes in the way the drive operates, so that will be good.

‘It is the same paddle shift as we ran last year, but aside from the engine and gearbox there is not really a common part with the old car. We have new uprights that are lighter, run cooler and are stronger.’

The team added paddle shifting to the C6R, and carried

over the same system to the C7R, so from the 90lbs saving brought on the chassis, the overall weight of the car is only 25lbs lighter than its predecessor.

‘There are always things that you want to do things that are going to add weight, so you are easily able to absorb that,’ says Fehan. ‘They were the production numbers. You do all your FEA on it, and are tempted to put in that extra bar in the roll cage that will increase stiffness just a little bit, but you hate to add the weight because it is high up. Here we didn’t have to do that.’

By regulation the GT cars have to run an air conditioning system, and the Pratt & Miller team have taken the compressor from the Chevrolet Volt, which takes less than 1bhp to drive it, and mounted the whole system at the rear of the car. ‘We have developed a system that has a tremendous amount of absorption in it,’ says Fehan. ‘We are working to improve the condenser unit - that is the biggest struggle. If you look at the compressor as the heart of an AC unit, it is the condensing coil that is where the temperature drop occurs - that is where you have to make the transfer.

‘We have a new system coming that uses something a little bit different to this, and I am hoping that we have it tested and ready before Le Mans.’

The team has taken a pragmatic approach to safety in the C7R, refusing to run the narrow seat belts, or the adjustable seat that some of their competitors feature, but the biggest step in safety is the side impact protection system that was developed in conjunction with the Wayne State University, a premier research institution in Detroit, Michigan.

The system is basically a box made out of carbon Kevlar with an expanded honeycomb interior that absorbs impact from foreign objects.

‘We built a roll cage, and the honeycomb aluminium is a purchasable material and has different crush rates,’ says Fehan. ‘We went through a major programme of crush testing to determine which would provide protection and absorption, without being rigid like a NASCAR bar, or just nothing.

‘We had an incident last year with Johnny O’Connell in the Cadillac, where something punctured the door. We don’t know what, but it went into the box. The Kevlar stopped it from penetrating. That is an added advantage. I have been through some tragedies with drivers and couldn’t do without it.’

The C7R will compete in the TUSCC this year, and at the Le Mans 24 hours in June.



The C7R has a new side impact protection system, made from carbon Kevlar with an expanded honeycomb interior

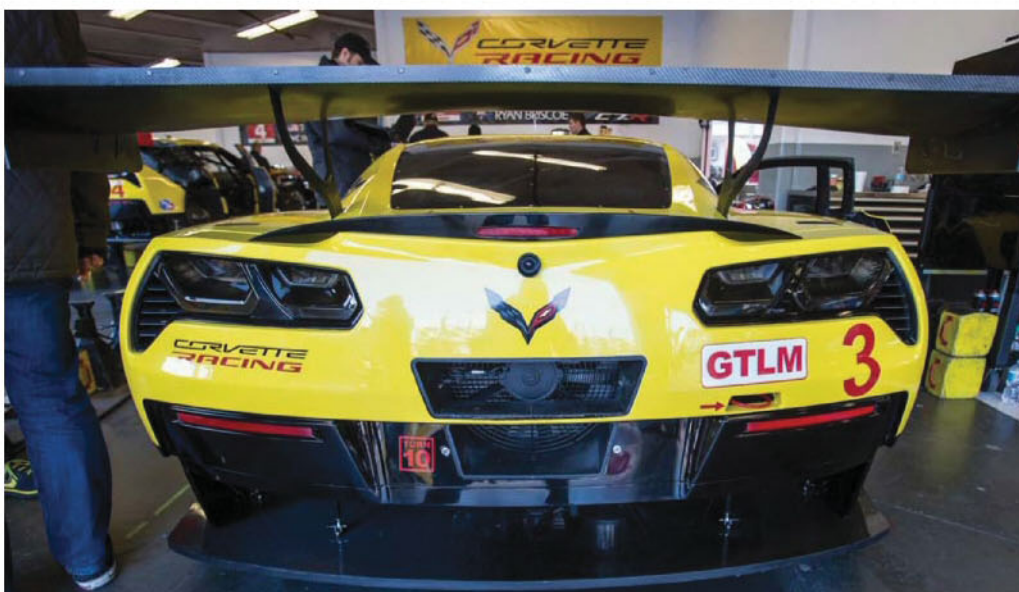

The team has used production parts to build the air con system at the rear, largely taken from the Chevrolet Volt

JOHN BROOKS



AT THE HEART
OF THE WORLD'S
MOST POWERFUL
ENGINES



www.arrowprecision.com

Give us your requirements and we'll find a high-performance solution,
no matter how extreme.

Call our sales team: +44 (0) 1455 234200 Email us: enquiries@arrowprecision.com

Composite thinking

An English constructor with ambitions in LMP2 is switching from racing metal chassis to composites to contest the ACO's brand new class

BY SAM COLLINS

In the coming years, LMP3 is expected to become one of the biggest classes in racing. The new category was announced by the ACO at the end of 2013, and will run for the first time this season. Initially, the cars will use carbon fibre monocoques built to the FIA CN rules, but for 2015 the first proper LMP3 designs will hit the track. So far, two companies - Ligier and Juno - have announced that they will produce bespoke cars for the rules, while the Pescarolo 02 will be adapted to the new class.

Juno is an English constructor founded in 1999 by former Williams F1 engineer Ewan Baldry. Over the years it has produced a long line of highly competitive cars, and at Autosport International in January revealed that it is developing an innovative new design for LMP3.

'Doing LMP3 is a natural progression for us, as we have been doing small sportscars like our CN and endurance racing products,' says Baldry. 'Our ambitions are LMP2 and beyond, so LMP3 is perfect. We actually started the design of the new car with the intention of it being a new FIA CN rules car, as we had realised that we needed to come up with a carbon chassis to progress in CN, while our metal car is still a frontrunner. But the market these days has an expectation for carbon fibre monocoques. Before we pressed the button to go into production, the LMP3 category was announced by the ACO. It's lucky they announced it when they did, because otherwise we could have stitched ourselves up a little bit, so we now have to ensure that the new design complies with LMP3 too.'

Developing a carbon fibre monocoque is not something Juno has experience of, with all

of its previous offerings having used metal chassis. 'We have had ambitions in the composites region for years, but there was always the slight hurdle of how we would fund its development,' says Baldry. 'But we were lucky enough to get funding from the Technology Strategy board [TSB].'

The TSB was set up by the British Government to help small companies develop innovative projects. Juno - along with its regular collaborator EPM Technology - was given £100,000 by the scheme in order to develop what it calls Affordable Structural Composites.

The project aims to develop innovative manufacturing processes to make advanced composite structures a commercially viable choice for lower cost competition cars. While the project doesn't claim that it will provide a solution to enable advanced structural composites to be used in everyday car manufacture, it is expected to

push the technology forward and to provide information as to how the technology can be developed further such that it is soon a common phenomenon.

'The main idea of the project is working out how to make composites more affordable,' says Baldry. 'EPM do a lot of subcontract work to Formula 1 teams, so very high end stuff, but they want to find ways of bringing composites more to the mainstream. The major innovation is really just to minimise the production times. Normally a chassis would be made in two halves which are then bonded together. To do that, you have very deep and complex moulds that are hard to get into and very fiddly to work with. The idea for our project is to use more components, but for them to be shallower. As a result, the chassis will be a multi-piece monocoque which makes it much easier to process.'

'This gives savings in terms of cutting the time needed for laminating, but also the time needed for curing. Some components are pressure moulded

using a heated mould, so the cure is much quicker. This way, we are not reliant on big autoclaves. Also, with the shallower component, rather than using a big vacuum bag you can have pre-formed rubberised bags that can be used repeatedly, which kind of clip on to the mould.'

The exact form that the new Juno LMP3 will take has yet to be confirmed, but the renderings seen on these pages are what the company is working with currently. However, design work cannot be completed until the technical regulations are finalised.

When the LMP3 category was first announced, the image used by the ACO to illustrate what it envisaged the cars looking like was of the Pescarolo 02 Coupé, but as discussed last month there is some controversy about the engine fitted to that design. 'That car has a big Chevy engine, and if LMP3 does go down that road it will be another missed opportunity,' says Baldry. 'Those engines of course are very cheap to get performance from, but the result is that you then need a very big gearbox to take that performance and big brakes to slow the car down. Everything starts to get heavy, and so the performance has to come back to you through expense.'

FIA CN cars currently lap between 1-2 seconds faster

"We have had ambitions in the composites region for years, but we didn't know how we would fund its development"

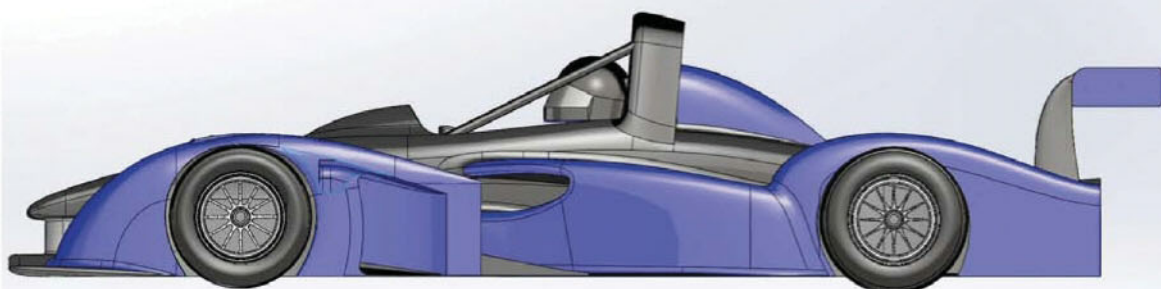

than GTE cars, which is already in the region where the ACO has said that it wants to see LMP3 running. But Baldry hopes that the new class will bring a performance boost too: 'I think the way to go is to keep the cars light - under 600kg - but the cars will still have to go through the rigorous crash and structural testing, which we conduct at the Cranfield Impact Centre. Already the safety record in CN is incredible, so I don't see an issue with going for lighter cars. I think it would be great to see a small capacity turbocharged engine mandated, as that's the way the automotive market is going. Maybe in the future, some kind of hybrid system could be introduced, I know Flybrid has a new low cost lightweight system on the drawing board at the moment, and that could be perfect.'

While the FIA CN cars fitted with 2-litre engines have a minimum weight of 535kg, Baldry actually wants a weight increase. 'I think it would be better with

a 575-580kg limit, with about 300bhp - I think that would give the lap time that they want,' he says. 'But I think it would be tough to build a closed cockpit car to that weight limit.'

The Pescarolo 02, with closed roof and Chevy engine, tips the scales at 860kg.

'With the closed cockpit, it's far more complex than just the roof - you have to fit wipers, doors, cool the cockpit... its not impossible but it's more tricky than it needs to be,' he adds. 'Also the ingress/ egress side may end up being a bit tricky with amateur drivers. I think if you look at LMP2 as well, where their closed cars do not seem to have any advantage over the open cars - it's just far simpler to build an open cockpit car and that keeps

the cost down again. It is also hard to make a good closed cockpit car because of the roll hoop regs in CN. The rear roll hoops have to be quite wide and high - as you see with the Pescarolo and the Zulltec. It reminds me of the original Daytona Prototypes, a bit of a hearse aesthetically.'

As it seems almost certain that the new Juno will be an open car, Baldry has pushed ahead with its aerodynamic development, using some Formula 1 contacts in the process.

'Aerodynamically, the car will be a step forward too, we have an existing relationship with TMG in Cologne, who did a lot with our current car,' he says. 'The work they did on the 2013 car found three seconds in lap time over

the 2009 design, but the two look almost identical. It was all small details, done in CFD. We could do it in the wind tunnel, but the budget is not there. We pay for 10 calculations with TMG, and we have not used them all yet. Every step we made was a significant improvement, but more importantly correlated really well with the track.

'It's no secret that Jason Somerville, the head of aerodynamics at Williams is involved, and in his spare time he reviews the figures and steers us where to go. For the LMP3, we have done our first CFD run, and straightaway found a 60 point gain around a GP circuit that can equate to 1.8 seconds. We are confident that we can carry that and more over to the track. One of the biggest gains over the old car is the raised foot box - the low footbox of the old car gave us limitations on the undertray at the front, and that's the key area for the aero performance.'

The new Juno will make its race debut in either the European or Asian Le Mans Series in 2015, with the first track running likely late in 2014. But even before the first proper LMP3 is built, a Juno will run in the LMP3 class, as for the first year CN rules cars are allowed to compete in the Asian Le Mans Series as LMP3s. A special car has been sold to a Malaysian customer who will race it until the proper LMP3 chassis is ready. 'It's a kind of hybrid of what we want to do,' says Baldry. 'Certainly taking the feedback we're getting from our customers, LMP3 is really exciting. VdeV is fantastic, but is still has something of a regional, French feel. But our drivers aspire to LMP2, and so do we, so LMP3 is a perfect, affordable route to that.'

The chassis will also form the basis of a dedicated track day car which could have an unusual look. 'It will sell for £50,000-£60,000,' he says. 'We are looking at making it a KTM X-Bow, BAC Mono sort of competitor. We are teaming up with Coventry University and will give the students there the chassis structure and crash boxes as a basis - the rest is open book, and they can do whatever they like. We will probably see that in 2015 too.'

"It would be great to see a small capacity turbocharged engine mandated, as that's the way the automotive market is going"

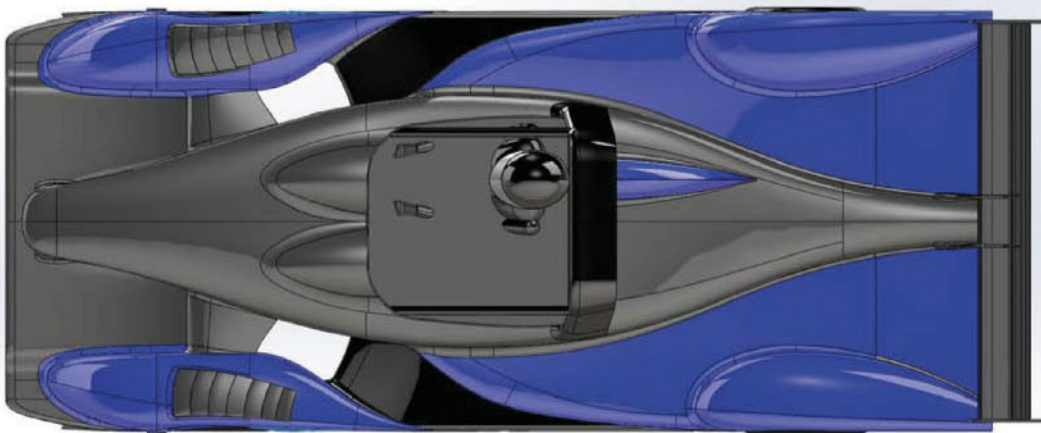

These renderings represent a work-in-progress of the new Juno, while it awaits finalised technical regs from the ACO



The digital innovator

One of the true design greats of the computer age, Britain's John Barnard introduced and honed a whole host of technologies that are now taken for granted in Formula 1

BY DR CHARLES CLARKE



"When people asked me where I did all the wind tunnel work, it was all done on the kitchen table in Wembley while I was having breakfast"

How exactly do you resolve the enigma that is John Barnard? To some he is an F1 legend, a design god, responsible for more innovation in F1 than even Colin Chapman. To others he's a nightmare to work with, always ranting and raving, and throwing his toys out of the pram.

I only knew him in a professional context for the last 10 years or so of his F1 career when his favourite phrase was 'no compromise'. The first word was often spoken on its own during discussions, but the second? Never.

But whatever your view, his record stands for itself.

Chapman came from the slide rule and log table era - a man of real vision, who had no way of analysing what he was building. So we had full-size prototypes racing, like wings on stork's legs that hadn't even been subjected to any analytical 'basket case' test.

Barnard, on the other hand, was the F1 innovator of the computer age who managed to introduce and perfect, the things we take for granted in today's F1.

His list of firsts is impressive. First with the carbon fibre



monocoque chassis, first with (reliable) fabricated titanium components, first to run scale wheels directly on the belt in a rolling road in a wind tunnel and so avoid the 'compromise' of having stationary wooden wheels set to run just above the belt.

Other firsts include: 'flexures' replacing ball joints on suspension (1994 Ferrari); all the instruments on the steering wheel replacing the dashboard that had become almost impossible to see in a modern cockpit (1996 Ferrari); the first to make a quick-release nose box catch (Benetton 1990); first with in-house designed calipers for carbon brakes (1984 McLaren) and testing a carbon clutch in 1986 with McLaren manufactured plates. Also: first semi-automatic flappy paddle gearbox (Ferrari), and first with a fabricated titanium and then carbon fibre gearbox casing.

John Barnard's debut in racing was at Lola in 1968 as a junior designer after taking the HND training route at technical college. 'University wasn't something

offered to students at my level in society,' says Barnard. 'My parents were hard-working people, mother had her own shop and father worked for the Glacier Metal Company in programme planning.

'I carried on at technical college doing "day release" courses until I was about 23. I got an HND (Higher National Diploma) in mechanical engineering. Although it wasn't university, I had a good all-round education in as much as I learned most things from first principles, which proved to be really useful later on in my career.'

At Lola he was dropped in at the deep end, designing their first and only Super Vee when the new formula came out. He did this by himself, and then when the first car was built he found himself on the stand in Earls Court helping to sell it at a trade show. Later, he worked on some of Lola's classic sportscars including the T260 CanAm car, the T280 and the T290 sportscars.

Lola was a fertile training ground for many racing engineers.

There, Barnard worked alongside Patrick Head and they became and remain good friends. Eric Broadley, the Lola boss, has been quoted in these pages as saying, 'Head, particularly, was very good, a hands-on, natural engineer. He would get straight to the root of a problem. His drawings weren't very good though! Barnard was very different. He had his own ideas. They weren't always right, but he was brilliant as well.'

This affection works both ways - Barnard is very grateful for the start that Broadley provided and he tried to do the same for other young engineers in his various professional incarnations.

Throughout our conversations, there is a real affection and enthusiasm for the sport which returned the favour by christening him 'JB', long before Jensen came along.

In 1972 he moved to McLaren and for the next three years worked with Gordon Coppuck on the design of the M16 IndyCar and the F1 world championship-winning M23. He did the McLaren

M25 Formula 5000 car on his own with no input from anyone, and when Denny Hulme tested the car at Silverstone he was very quick and liked the car a lot.

In mid-1975, he joined Vel's Parnelli Jones team in California, where he fixed Maurice Phillippe's VPJ4 for F1 and then adapted it into a winning IndyCar design.

Next came the Chaparral 2K IndyCar for Jim Hall. 'This was really quite a step forward for IndyCars. It was the first proper ground-effect IndyCar and it's still my favourite car,' says Barnard. 'It was designed in my dad's front room in Wembley! It just went together and worked. When people asked where I did the wind tunnel work, I said: "At the kitchen table while I was having breakfast." That car put me on the map.'

At the end of Barnard's stint in the US, Johnny Rutherford won the 1980 Indy 500 and the IndyCar title in the Chaparral 2K, which drew Barnard to the attention of Ron Dennis of the Project 4 team. Dennis agreed to underwrite the design and construction of a revolutionary grand prix car with an entirely composite chassis.

'Ron wanted to go into F1 and we agreed a deal at the end of 1979, which meant I didn't have to race in 1980,' says Barnard. 'To have a whole year to make a car ready to race was unusual. Ground effect was in full flow, and to optimise that, I wanted the best underwing possible, which meant having a narrow chassis. When you narrow the chassis - certainly at the bottom - you start to lose structural stiffness. I needed to get it back and started thinking about a steel-skin monocoque instead of an aluminium one, but of course, that gets too heavy. That's when the idea of making a carbon fibre chassis began to take shape in my head.'

The first carbon monocoque was actually built at Project 4 in 1980 - the first McLaren raced with it in 1981. 'This is quite important because there are people who say that Lotus made one before us or at the same time,' says Barnard. 'In fact the Lotus was a bit of a halfway house carbon chassis

Main pic: Mario Andretti in the Parnelli VPJ4 Ford at the 1975 German Grand Prix
Right: John Barnard in conversation with Niki Lauda and Alain Prost in 1984
Bottom right: Lauda racing to victory in the McLaren MP4 at Monza, 1984





and had a semi-cured sandwich skin folded around machined aluminium bulkheads.'

This led to the world's first full carbon composite monocoque, the McLaren MP4/1, in 1981. This was developed into world championship winners for 1984, 1985 and 1986. But then Barnard left for Ferrari, where he introduced the paddle-shift electronic gearchange system which became another F1 standard.

'The truth is, I got tired of trying to find a nice route through the chassis, past the engine and down into the gearbox for the shifting rod,' says Barnard. 'And then this awful gear lever getting in the way of everything and making this big bulge on the side of the cockpit. Surely all I needed was a button on the steering wheel and a little hydraulic cylinder that shifts the gears? You can still have a clutch. The driver just has to get used to pushing a button instead of moving a gear lever. If I do that, all I need is an electrical cable going to the back of the car and not all these rods and linkages. So that was the thinking behind it. Once you start developing the idea, a whole stream of things emerge, such as automatic shifting and a guarantee of no engine over-revving.'

Barnard also introduced a new aero concept with the radiator flow exiting at the back



Top: a cutaway illustration of the McLaren M23-Ford

Above: James Hunt racing in the M23 at Monte Carlo in 1976

of all enclosing bodywork on the Type 639 (1988), which never raced, later becoming the Type 640 in 1989.

Barnard's design style is old school - there was always a four-metre drawing board or layout table around, where full-size car plots could be the centre of design reviews to be annotated and adjusted. He is a draughtsman at heart who relies on lines, curves and contours to generate the 3D shape, with the underlying proviso that if it 'looked right' it probably was.

Even though he recognised the contribution that computers could make to engineering precision, he lamented its arrival as he lost some control. In the old days he could wander round the design office when everyone had

gone home, and build a mental picture of progress just by looking at everyone's drawings - that's not really possible with the computer, because people work in so many different ways.

While working at McLaren, Barnard established a home base in Surrey, which he was reluctant to leave for family reasons. Consequently, when he was approached by Ferrari in 1987, he was able to dictate his terms to the Italian company who sponsored his own design centre - Ferrari Guildford Technical Office or Ferrari GTO - delightful symmetry with the car of the same name.

Soon after that, he was lured to Benetton and established the Benetton Advanced Research Group at Godalming in Surrey, and

designed the B191, which formed the basis for the 1994 world championship-winning B194. While working at Benetton, he designed the car in which Michael Schumacher won the first of his 91 grands prix, and then returned to Ferrari, where Schumacher scored the last GP win in a Barnard-designed car.

After leaving Benetton, Barnard worked on a secret Toyota F1 design for the TOMS company, but when that plan failed to get off the ground, he returned to Ferrari. It was at this point that he crystallised his ideas with regard to developing a successful F1 team.

'Success in Formula 1 is all about discipline,' he says. 'You need to know what you can do, over what period and have a good idea of where you want to get to in a given amount of time. Formula 1 designers are notoriously optimistic with regard to what they can achieve in a given time. The most ideal of situations for me is to start with a clean sheet of paper, to build a team from the ground up. Moving into an existing team is perhaps the worst challenge of all, with old cultures and old prejudices. Old cultures and prejudices waste time and lead to compromise. Compromise doesn't win races.'

Time is critical in Formula 1, so all the tools must be the fastest available and they must be integrated. 'F1 is a deadline-driven activity - it's very much a binary occupation - it either works or it doesn't,' says Barnard. 'You don't win prizes in F1 for being late for the start of a race. In fact, in most cases you risk losing a large amount of money from your sponsors if you don't turn up at each race, ready to start. Time is the only thing you can't buy more of in F1.'

The complex machining technology of today is an important ingredient for success in Formula 1 - indeed, things like five-axis machining centres and four-axis lathes are now having a real impact on production times. 'These tools give me more design freedom and allow me to make

"Moving into an existing team is perhaps the worst challenge of all. Old cultures and prejudices waste time and lead to compromises"



Manchester Metrology LTD

Portable Measurement Solutions

ONSITE INSPECTION AND NON CONTACT LASER SCANNING SERVICES



FARO ARM INSPECTION

HIRE AND LEASING OF FARO ARMS, GAGES, LASER TRACKERS AND LASER SCANNERS.
ACCESSORIES, PROBES, MAGMOUNTS, LEAPFROG CONES AND MUCH MORE.

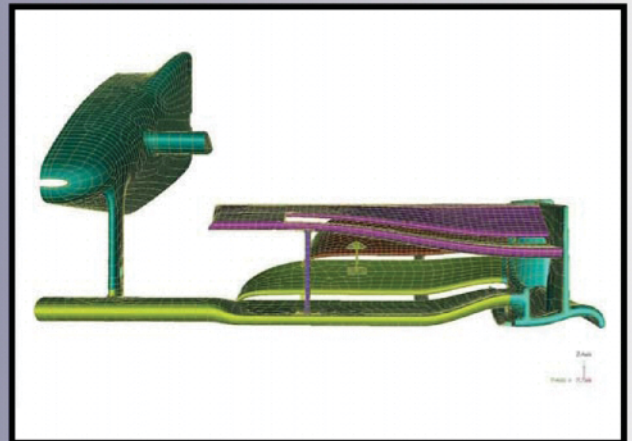

WWW.MANCHESTER-METROLOGY.COM

Manchester Metrology Ltd, Unit 12 Greenside Lane Industrial Estate
Greenside Lane, Droylsden, Manchester M43 7AJ
Tel: 0161 637 8744 • Fax: 0161 425 0944
info@manchester-metrology.com



Above: Mario Andretti in the Penske PC9-Cosworth, running second early in the 1980 IndyCar race at Phoenix
Left: Martin Brundle in the Benetton B192 Ford at the 1992 French Grand Prix at Magny-Cours

The idea was that FDD would be working on next year's car. 'If you're having a good season, the moment you start looking at the new car, it distracts you from the current season and at the same time the new car gets closer and closer to the limit. So you have to make decisions without all the proper wind tunnel work,' says Barnard. 'This was a chance to avoid all that, but it never happened.'

At the conclusion of this arrangement in mid-1997, Barnard bought FDD from Ferrari and established B3 Technologies. Barnard then signed a deal to work for Arrows. This didn't last very long, as in the middle of 1998 Barnard and Tom Walkinshaw ran into contractual difficulties. The dispute was settled in December 1998 and Barnard signed an agreement to work as a technical consultant to Prost in 1999 while continuing to run B3 Technologies. After Prost closed down, Barnard decided to turn his attention motorcycle racing and at the start of 2003 became technical director of Kenny Roberts's MotoGP team.

Italian team at a new design office called Ferrari Design and Development (FDD), very close to the old Ferrari GTO premises at Shalford, Surrey.

This time he was not overall technical director as in his first Ferrari stint, but as technical director of FDD, Guildford. 'I told Ferrari we couldn't do what we did last time, which was to put me in charge and run everything from the UK - that didn't work,' he says. 'We needed to set up a design office and wind tunnel in the UK and work on next season's car. Harvey Postlethwaite would look after the race team from Maranello and the racecars, modifying them for the season in hand. That was how it was supposed to work. Harvey was fluent in Italian, and we could communicate effectively no matter how far apart we were.'

Six months into the arrangement, Postlethwaite came back to the UK as technical director for Tyrrell - also in Surrey. 'So then I had Ferrari on the phone, asking what we were going to do for the next race,' says Barnard. 'I told them this wouldn't work, but that's how it went for the next four-and-a-half years.'

Although JB is now 'officially' retired, great engineers never stop engineering. He consults on a number of projects, most notably his collaboration with his furniture design partner Terence Woodgate and his daughter Jennifer on 'designer' carbon fibre furniture and other high end products.

'I am also partway through designing a "new concept" folding bike, just for fun,' says Barnard. 'But hopefully I will get a prototype made some day.'

He lives in Switzerland and has a house with a view of Lake Geneva 'to die for', while his close neighbours are rock stars.

There is an AO drawing board in his study, and even when commissioning new external light fittings for the new house there is a pristine 2H perfect, full orthographic drawing of the light fitting on the drawing board. Still 'no compromise' engineering precision - no 'back of a cigarette packet' for JB. 

more complex shapes, more accurately and more quickly,' says Barnard. 'Any time saved in the manufacturing process means more time spent on development and if this is properly directed, ultimately more performance.'

'As the use of computers grows, it is crucial to have fast hardware and fast software for the design and manufacturing stages,' says Barnard. 'Small, incremental gains are a help, but it is the large time savings that we are looking for. You don't need more iterations or to do more "what if" analysis - that is nice to have - what you need to have is the ability to

do existing jobs faster. With fast tools, you find out if you've mucked up quicker.'

Many teams in F1, because money is scarce, choose either the cheapest systems or are willing to accept 'free' systems in exchange for advertising. This generally, does not produce the best solution. 'And because I firmly believe in the theory of no compromise, I needed the best technical solution from the best technical partners,' says Barnard.

In mid-1992, Ferrari offered Barnard his own design office once again, and so he went back to working for the famous

"It's crucial to have fast hardware and software - small gains are a help, but it's the large time savings that we are looking for"

THANKS FOR A GREAT SEASON

25 HOURS OF THUNDERHILL CHAMPION | 5 VLN WINS

Our Partners Rock!

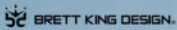

RACE AT THE NÜRBURGRING

Opportunities are available in the VLN Series and the 24 Hours Nürburgring in some of the top race cars in the world, including the Audi TT RS, R8 LMS and RS4.

Photo: Larry Chen

To learn more, visit: race-the-ring.com | rotekracing.com



WorldMags.net



THANK YOU

TO EVERY MOTORSPORT
PROFESSIONAL AND EXHIBITOR
THAT ATTENDED AUTOSPORT
ENGINEERING 2014. ALL THE
BEST FOR THE NEW SEASON,
WE'LL SEE YOU AGAIN AT
BIRMINGHAM'S NEC NEXT YEAR.

SAVE THE DATE
8-11 JANUARY 2015
AUTOSPORTINTERNATIONAL.COM

 **AUTOSPORT**
INTERNATIONAL
Engineering Show

In association with  **Racecar**
engineering

WorldMags.net

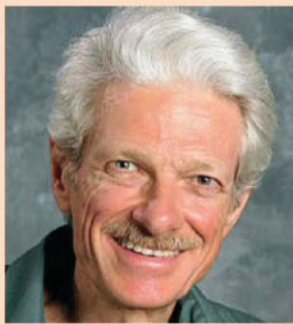

Mark Ortiz Automotive is a chassis consultancy service primarily serving oval track and road racers. Here Mark answers your chassis setup and handling queries. If you have a question for him, get in touch.

E: markortizauto@windstream.net

T: +1 704-933-8876

A: Mark Ortiz,
155 Wankel Drive, Kannapolis
NC 28083-8200, USA

Suspension interconnection

An illuminating exchange on a theoretical design with our expert

QUESTION

I have long been fascinated by the principles of front-rear interconnected suspension systems. I have developed several theoretical designs over the years, and shall hopefully have the opportunity to build a working vehicle incorporating such a system some day. The focus of my thinking tends to be on high-performance road vehicles.

I have two questions, the latter of which arises from the former:

1. Having devised an arrangement of mechanical links to effect front-rear interconnection of roll resistance independently of bounce/heave/pitch motions, and subsequently calculating the spring rates necessary to achieve the desired roll angles, the question arose whether it was necessary to retain any overall roll compliance whatsoever. My concern was primarily about ride

comfort, as although the front and rear axles might be sprung fairly softly, a component of any single-wheel bump would still be felt as either a small lateral jolt or a small rotation about the roll axis, or both. And it occurred to me that this was likely to be so unless my roll-control springing was so soft that the desired roll angles could not be achieved. And if that were the case, why not just dispense with roll-control springing altogether? That would certainly allow the interlink system to be much simplified, which is always good.

I know that some roll would remain due to deflection of the tyres. I am aware that Citroën built an SM with an experimental zero-roll suspension around 1970, which was by all accounts dynamically successful. I have also had some correspondence with the inventor of this system - check out www.cairosuspension.co.za. It is a hydraulic system which eliminates overall roll except that arising from tyre deflection but, being oriented at low-speed off-road vehicles, the inventor did not consider the effects of the front-rear distribution of lateral weight transfer. I suggested to him that the handling balance of his personal Land-Rover, though it is already far superior to stock, might be made tuneable by making the spring base on at least one axle adjustable. So it seems to me that people can and do live with suspension systems that do not allow any roll except that arising from tyre deflection.

I have heard some talk about a bit of roll being desirable for driver feel, but I am not convinced that the inner ear can distinguish between (at least steady) roll and lateral acceleration. I cannot see

the visible horizon having much influence, except in extreme cases. My own experience is that it is more about feeling steering weight/feedback against lateral and yaw acceleration. That's why I don't like power steering.

My question is, how good an idea is zero-roll, really? Given that I can a) achieve zero warp stiffness, b) control overall roll independently of other suspension movements, and c) distribute front-rear weight transfer through the geometry of the interlinkage, do I need to incorporate overall roll compliance? Can I go ahead and make those links solid, or is there something I am missing entirely?

2. Provided the zero-roll solution is viable, how does this alter our approach to camber recovery? Would it become more practical to use systems like pure trailing arms, whose lack of camber recovery makes them less desirable in many instances for conventional suspension? If all overall roll arises from tyre deflection, surely the suspension geometry is irrelevant to the resulting camber change? And in the case of single-wheel bumps, surely the probability of any given camber change being desirable would tend to be equal to the probability of any other camber change - or no change at all - being desirable? Especially if the changes in question aren't extreme?

I am thinking of my Morris Minor, where the conventional wisdom is to reduce understeer by increasing front roll stiffness, contrary to theory, because reducing roll overall reduces the camber change at the front. Can one take this a (large) step further?

Your thoughts on this would be much appreciated.

People live with systems that do not allow any roll except that arising from tyre deflection

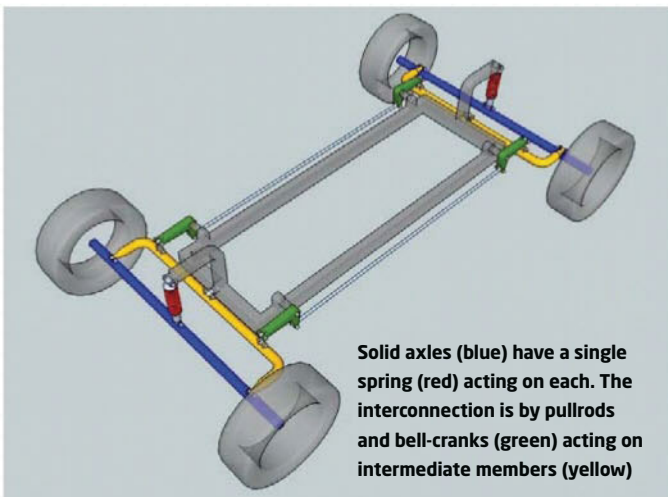

Solid axles (blue) have a single spring (red) acting on each. The interconnection is by pullrods and bell-cranks (green) acting on intermediate members (yellow)

THE CONSULTANT SAYS

Briefly, I don't think it's necessary for a car to have suspension roll for the driver to feel when the limit of adhesion is reached or approached. You can certainly feel it just fine on a go-kart.

But making the suspension completely rigid in roll would probably compromise roadholding as well as comfort. Sometimes road irregularities deflect both wheels on the same side in the same direction. I would also have to see how you're managing front/rear lateral load transfer distribution before I could say if you're actually achieving good control of that or not.

Regarding the camber question – yes you could use geometry that gives zero camber change in ride, and still have no camber change in roll, since there is no roll. Camber properties would be excellent. In certain situations you'd have large sprung mass accelerations and large wheel load changes, but camber control would be great.

Roll due to tyre compliance would produce camber change equal to that roll component.

THE CORRESPONDENT SAYS

The image on the previous page shows a very simple iteration of the concept, with solid axles front and rear (blue) and a single spring (red) acting on each. The interconnection is by pullrods and bell-cranks (green) acting on intermediate members (yellow) which pivot about a ball-connection to the vehicle structure. In bump/pitch, these members rotate about an axis through the ball-connection and the bell-crank links, while in roll/warp they follow the rotation of the respective axles.

Note that not all axle location is shown. The yellow members do, however, serve as axle lateral locating devices. Moreover, the location needn't be by a ball joint and therefore limited for roll centre location – it could be by links describing an instant centre etc. There are hundreds of possible elaborations on the basic concept in the image, including some which involve independent suspension.

You will notice that the system articulates freely in warp. The ERMD is determined by the

leverage of the bell-cranks. It is proportional to the attitude the vehicle adopts at rest, relative to the angle between the front and rear axles. Hitherto, the pullrods have incorporated some sort of stiff tensile spring to allow a bit of roll compliance. So how bad would it be to lose these springs altogether, and have the pullrods solid as shown? How badly would the system be compromised? Would the result be a death-trap, or could it be an imperfect but fun little runabout?

The image below shows another effect of the intermediate member, of which I have of late

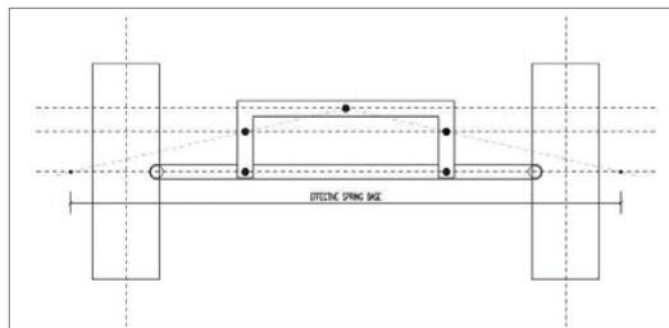

View of the spring base on the proposed warp-soft interconnected suspension

almost forgotten: if the bell-crank pivots on the intermediate member are not in line with the pivot to the vehicle structure but somewhere nearer the axle, the pullrods would be subject to some bump/pitch input, depending on the leverage in side view. As long as this remains greater than the leverage in end view, the result would be as if the spring base were greater than the track. This tends to the classic 2CV situation where the combined bump stiffness is greater than the pitch stiffness, but combined with amplified overall roll stiffness.

Such are speculations of this kind that even your preliminary comments have given me much food for thought: thank you. I think you have already convinced me to retain some roll compliance, though if you are agreeable, an explanation of why would be educational.

THE CONSULTANT SAYS

The system as you've drawn it would not be rigid in roll. If the bellcranks were attached to the axles, then it would be. As drawn, the yellow anti-roll bars resist roll but not warp, but they do not resist roll rigidly unless they are very fat. This is equivalent to what was done on rally cars under the kinetic patents, via hydraulic interconnection of the anti-roll bars. Your car would have roll resistance dependent on the rates of the yellow bars, which could be as soft or stiff as desired.

This illustrates the principle that any simple interconnection

of springing, using an anti-roll bar does the same thing, but the layout you've drawn also allows damping that's stiffer in roll than in ride. A somewhat similar effect can be achieved with a beam axle more simply, by mounting coilovers well above the roll centre and inclining them steeply. However, that approach has greater limitations than your system in terms of available motion ratios, and also inevitably produces a falling motion ratio in ride. Your idea, or some variation of it, might also be applicable to independent suspension. Motion ratios could also be increased by adding pushrods and bellcranks, although the system then starts to have a lot of pieces.

THE CORRESPONDENT SAYS

The yellow members are indeed intended to be pretty much rigid. I had something like a 3-inch hollow tube in mind.

THE CONSULTANT SAYS

OK. You can make them that way, or make them any stiffness you want, to tune the system as desired. This means that you don't need any additional complexity to have some roll compliance. The links connecting the bellcranks can still be rigid.

If you don't have roll compliance, maybe that means you don't need to damp roll either, but you probably should have some damping in warp anyway – even with no suspension roll and no resistance at all in warp – if you want to use the vehicle at high speed. Otherwise I can imagine getting warp oscillation of the unsprung components on the tyres.

With beam axles, suspension roll does not affect camber. That's why any increase in roll resistance, even front roll resistance, will sometimes reduce understeer in a car with little camber recovery in roll at the front and good camber recovery at the rear. Except in tall vehicles, there isn't much to be gained from reducing roll if the vehicle has beam axles at both ends, at least in terms of steady-state cornering. With independent suspension, it is much more important to reduce roll, as it directly affects camber control.

Making the suspension rigid in roll would probably compromise roadholding as well as comfort



FIA CERTIFIED FUEL BLADDERS

Custom Rally Pro Cell



458 Ferrari



Viper GT3-R

- Shortest lead times in the industry
- CAD modeling = precision fitment
- Dual fuel / ethanol compatibility
- Lightweight / flexible
- Custom containers available

HIGH-PERFORMANCE ACCESSORIES



High Performance Pumps Available From Fuel Safe



Redhead Drybreaks



Swirl Pot



CONTACT OUR EXCLUSIVE AGENT IN THE U.K.
Classic World Racing, Tel +44 (0) 1527 521050

www.fuelsafe.com
MADE IN USA



MOTORSPORT CONNECTORS M SERIES



A ratchet screw system enables quick and secure coupling of the connectors.

An innovative solution for harsh environments

- Very high contact density
- Ratchet screw coupling mechanism
- 6 different sizes
- Lightweight aluminium shell
- 2 to 114 contacts
- Optimum space saving
- Oil and fuel resistant
- IP 68
- High shock and vibration resistance
- Vibration absorption flange
- Arctic grip or knurled design
- Lightning test passed
- USB version available



LEMO SA - Switzerland

Phone: (+41 21) 695 16 00
Fax: (+41 21) 695 16 02
info@lemo.com



Contact your local partner on www.lemo.com



DOMINATE THE TRACK. RULE THE STREET.



IMPERIAL RANGE



METRIC RANGE



TENDER | HELPER

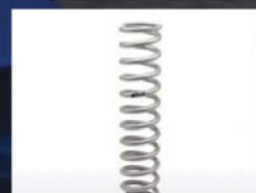

OFF ROAD



COIL SLEEVE



BUMP STOPS

ERS | Eibach Race Spring System

- Over 1,300 single components - main and tender springs - metric and imperial, various auxiliary race suspension accessories, ready and in stock on 5 continents
- Comprehensive Program of single components
- Single Main Springs with highest rate-linearity and lowest rate tolerance
- Progressive Characteristics via set-up of different springs serially - double or even triple spring combinations
- Extreme Low Weights achieved through Super Hi-Ten materials and manufacturing technology
- Smallest Solid heights, maximized spring travels and higher maximum loads
- Spring Surface Stabilization through specialized shot peening
- Every ERS Spring preset to block
- Block and Sag Resistant
- Smallest Tolerances and precise plane parallelism of spring ends
- High Dynamic Durability - under Motorsports conditions
- High quality corrosion protection by phosphating and epoxy coating
- Springs Printed with part-number (speaking code = rate and dimensions)
- Individual protective single box packaging



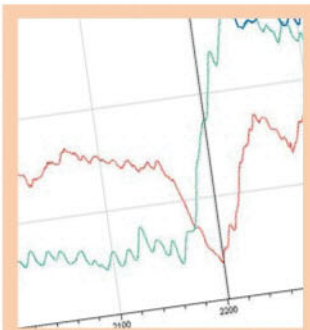

Databytes gives you essential insights to help you to improve your data analysis skills each month, as Cosworth's electronics engineers share tips and tweaks learned from years of experience with data systems

To allow you to view the images at a larger size they can now be found at www.racecar-engineering.com/databytes

Networking opportunities

Improvements to wireless technology - with ever-more reliable connections - are opening up new possibilities for race data transfer

Wireless technology is found everywhere around us, and racecars are no exception. Even at the lower tier of motorsport, some cars will have voice radios (although some series do not allow any communications).

At the other end, there is plenty of information floating through the airwaves, including telemetry, TV signals and timing information. In some cases, cars are even equipped with mobile phones, either to stream data from onboard cameras or as a

backup communication device in case of emergencies.

In a typical endurance racecar setup, there is of course a wired garage network, but then there can also be a wireless bridge over to the pit wall as there is not always a wired link under (or over) the pitlane. The cars will then also have a voice radio and data radio using standard RF transmission.

This is a proven and reliable method of communication, but has its downsides as well. Using RF radios for data has strict limitation on how much data can

be sent, so all channels need to be logged at a slow rate. It can also be a challenge to get good coverage at large circuits and often teams have to make do with significant dropouts in the data transmitted. There are ways to get better coverage with the standard RF telemetry, but the bandwidth is always going to be a limiting factor.

One piece of equipment that may appear a bit leftfield - but is still quite often used in racecars - is the standard GSM mobile phone. These are actually found

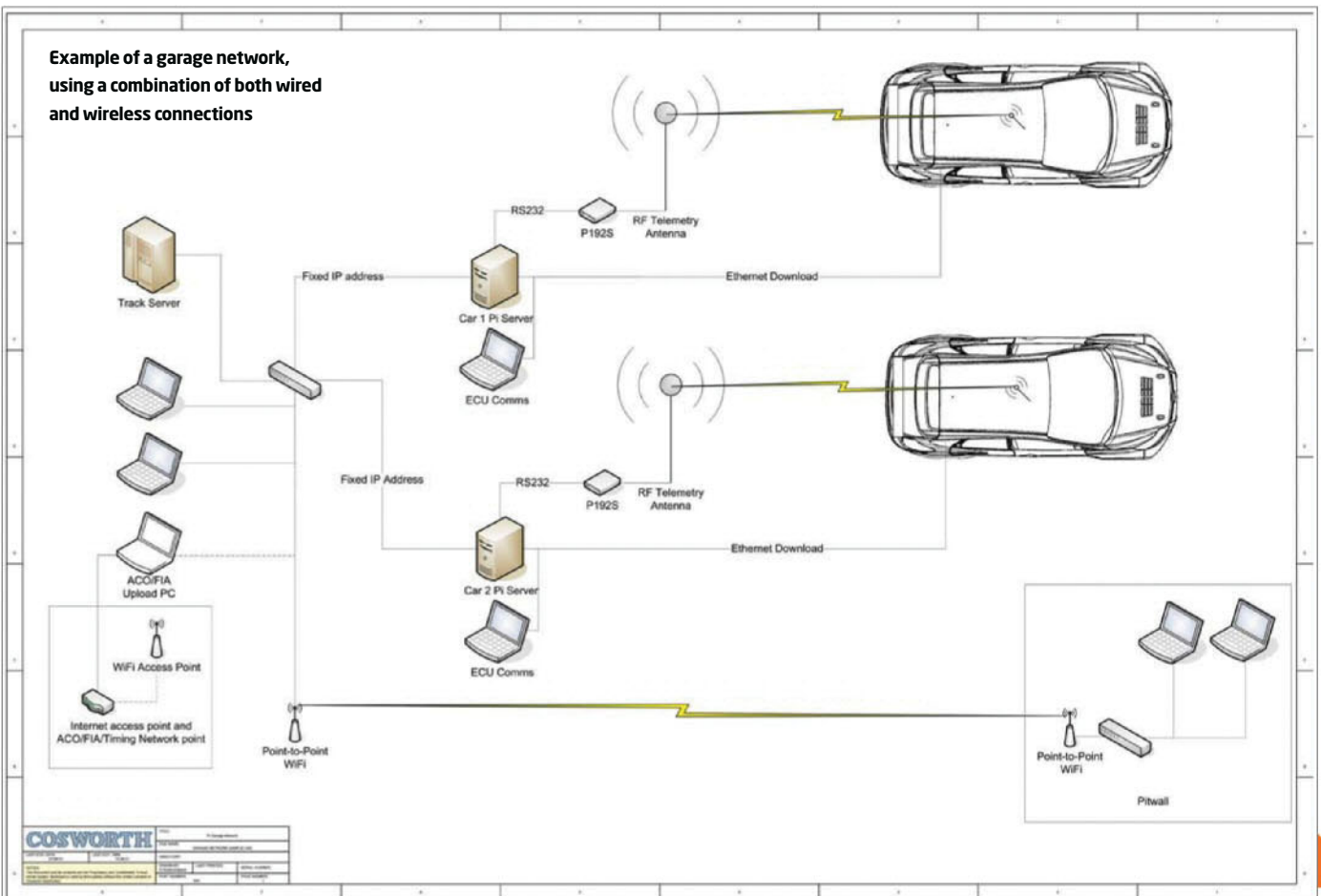

A small but effective traffic light system to aid mechanics and engineers. This can be either automatic, based on the logger status, or manually controlled

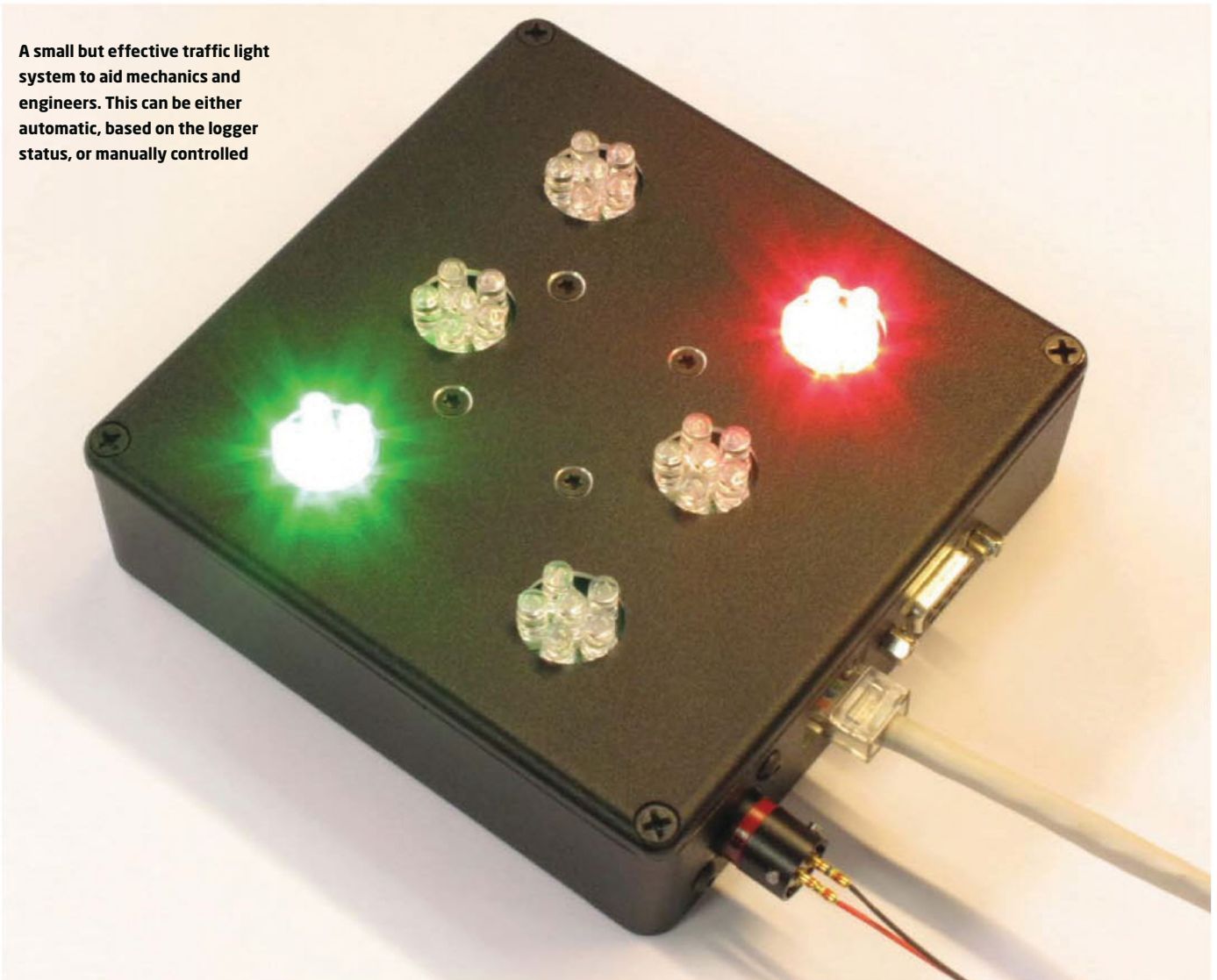

in some racecars, especially in endurance racecars which run on long circuits. These can be an important tool in case of any emergency. Mobile phones are also a useful communications tool in rally cars, particularly as in the case of some special stages, cars end up a long distance from the team control centre. In these cases, a Bluetooth module that connects with the intercom is a valuable tool in order to maintain communications between the drivers and the support crew.

The trend in today's technology world is for wires to be replaced with some kind of wireless functionality, and looking at a racecar there is one cable

specifically that could be done without. This is the download and communication lead between a laptop and the racecar systems. These tend to be ethernet connections, and hence could be replaced with a wireless bridge of some sort. In the heyday of wireless connections, the signals were not particularly strong or reliable and this would cause significant problems when downloading data - especially when sending a new setup to a device. If the connection was broken during a send procedure, the unit would have no configuration at all or - worse - a corrupt setup which could result in a catastrophic failure of the unit.

These days, however, advances in wi-fi technology mean that a very small wireless router can be fitted to the download connector of a car and provides a reliable connection from a distance. This method allows the engineers to communicate with the car without disturbing any mechanical work being done at the same time. A traffic light system, or a download light, can then alert the mechanics to not switch the car off during communications.

Technology is also helping when it comes to the bandwidth restrictions of RF radio telemetry. Various wireless technologies and even fourth generation mobile technology has come to aid in this

regard. One of the latest developments is the 4G Live-on-Air system, which uses the latest in mobile broadband technology to offer a 10Mbit/s bandwidth on a very high frequency carrier wave. This kind of system allows a team to run their telemetry channels at very high sample frequencies, which opens up all kinds of possibilities for on-the-fly analysis. 

COSWORTH

Produced in association
with Cosworth

Tel: +44 (0)1954 253600

Email: ceenquiries@cosworth.com

Website: www.cosworth.com

Advances in wi-fi mean that a wireless router can be fitted to the download connector of a car and provide reliable connections from a distance

WorldMags.net

What's the **secret** about the new 911 GT3 Cup's **new brakes?**



It's Quicker.



OFFICIAL PARTNER

PORSCHE
MOTORSPORT

PFC
BREMSE

WorldMags.net

www.pfcbrakes.com

1.800.521.8874



FERODO

RACING

DSUN

ENGINEERED FOR EQUILIBRIUM

RACE PROVEN

GT - TOURING CARS - FORMULA - RALLY

Circuit Supplies (UK) Ltd, Unit 8, Eden Court, Eden Way, Leighton Buzzard, Beds LU7 4FY

Tel: 01525 385 888 • Fax: 01525 385 898 • info@circuitsupplies.com • www.circuitsupplies.com

www.ferodoracing.com

WorldMags.net

FEDERAL
MOGUL

SUFFIX TO ORDER THIS MATERIAL IS 'Z' (e.g. FRP3087Z)



Simon McBeath offers aerodynamic advisory services under his own brand of SM Aerotechniques - www.sm-aerotechniques.co.uk. In these pages he uses data from MIRA to discuss common aerodynamic issues faced by racecar engineers

Produced in association with MIRA Ltd



Tel: +44 (0) 24-7635 5000
Email: enquiries@mira.co.uk
Website: www.mira.co.uk

Final examinations

In our concluding instalment of aero investigations into a Formula Student car, there are some interesting tales of yaw

Completing our studies of the aerodynamics of the University of Hertfordshire Formula Student Racing Team's UH16 2013 car, this month we look at the effects of yaw angle changes. The team had won a half-day session in the MIRA full-scale wind tunnel with *Racecar Engineering* for - in the opinion of the Institution of Mechanical Engineers - having the best media presence in the 2013 Formula Student competition. With full staff encouragement, the students put together and ran a really interesting session.

So far, we have looked at the baseline data that UH16 produced with the team's first full aero package. We have also studied the effects of different speeds, responses to wing flap angle changes front and rear, and the responses to changes of front wing height. To get a better understanding of the car's aerodynamics when not totally aligned with its direction of travel, the wind tunnel's turntable was then pressed into action. And with a car as compact as a

Formula Student, it was possible to examine quite large yaw angles without any concerns over wind tunnel test section blockage, so the students requested positive (nose to the right) and negative yaw angles of 1°, 5°, 10° and 20°. For these runs, the car was in its baseline configuration, with all wing flaps set to maximum angle. The test speed was 40mph, also used for most of the trials in this session as it most closely represented the competition environment that the car ran in. For reference, the aero coefficients in this baseline configuration at 40mph were rerun as part of the yaw trials - see **Table 1**.

To make the responses easy to see, they are presented over the page in graphical format. **Figure 1** shows the effects that changing yaw angle had on overall downforce expressed as -CL. Essentially there appeared to be little change in overall downforce even up to 10° yaw in either direction, but then downforce dropped by about 11 per cent compared to zero yaw at 20° yaw in either direction. Looking more

closely, there were small declines in downforce at the smaller yaw angles tested, but these declines did not really amount to anything much until yaw was above 10°. There was also a small difference in downforce at 20° between positive or negative yaw, and although this did not look significant here, it is something we will revisit.

Figure 2 shows the response of the drag coefficient to changing yaw angle, and here the pattern is rather different. Again, the superficial interpretation is that CD declined as yaw angle increased, but the detail is interesting here. First, the plots for positive and negative yaw are different, and the most likely explanation for this is that the car was not symmetrical - it featured a large radiator and cowl on the right-hand side and an exhaust and silencer on the left-hand side. So, rotating the car to the right made less difference to the CD at 5° and 10°, but by the time 20° had been reached there was little to choose between the CDs at +20° or -20°.

Downforce declined at smaller yaw angles - but this didn't amount to much until yaw was above 10°



The right side of the car featured a large radiator and cowl

Table 1: coefficients at 40mph on UH16 with maximum flaps angles front and rear

	CD	-CL	-CLfront	-CLrear	%front	-L/D
Baseline	1.154	1.750	0.974	0.777	55.7	1.517



The left side featured the exhaust tailpipe and heat shield

Figure 1: negative lift coefficient vs yaw angle

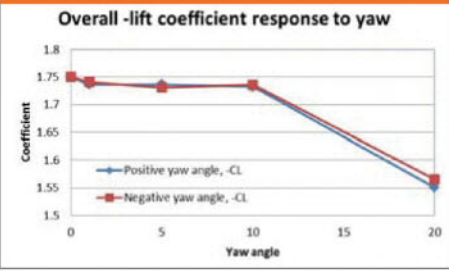

Figure 2: drag coefficient vs yaw angle

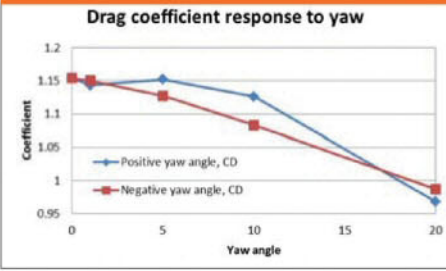

Figure 3: downforce vs yaw angle

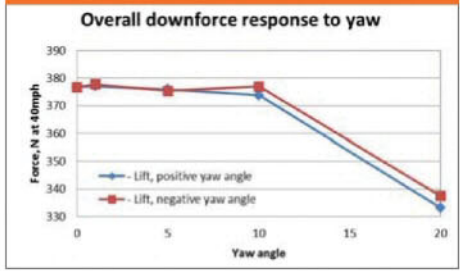

Figure 4: drag force vs yaw angle

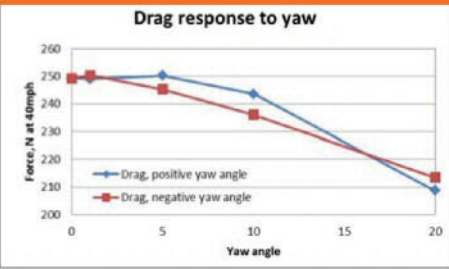

Figure 5: front downforce vs yaw angle

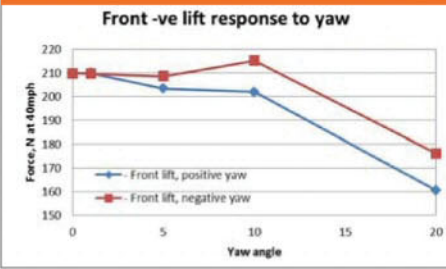

Figure 6: rear downforce vs yaw angle

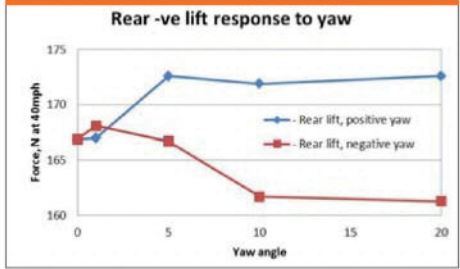

Figure 7: side force vs yaw

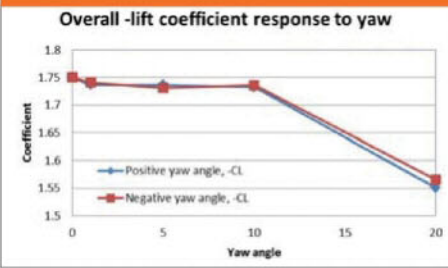
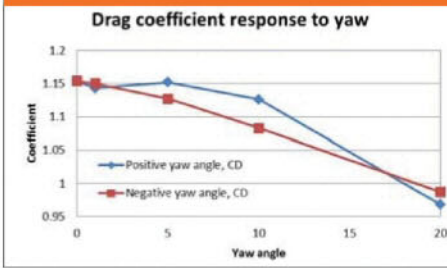

Figure 8: combination of drag and side forces vs yaw



FORCES FOR COURSES

Observant readers will by now be complaining that coefficients are calculated from measured forces with an equation that includes a term for the frontal area. And as a car is rotated so it is at an angle to the oncoming airflow, the effective frontal area changes. So **Figures 3 and 4** show overall downforce and drag as the forces directly measured at the wheels, and the plots look almost exactly the same as those in **Figures 1 and 2**. Clearly, the patterns we saw were not dependent on the effective changes of frontal area.

We'll come back to the apparent decline in drag force in a while, but let's look next at the vertical forces at the front and rear and the resultant patterns in balance shift with yaw.

Figure 5 shows how front downforce varied, and although the pattern was similar to that seen in **Figure 3**, clearly there

were differences between positive and negative yaw again, with approximately 10 per cent difference in front downforce depending on whether yaw was positive or negative. This, presumably, was the effect of the car's downstream asymmetry again, although it was intriguing to see that front downforce was actually 5N (1lb) higher at 10° negative yaw than it was at zero yaw - perhaps the rear downforce response might help to explain that.

Figure 6 shows the rear downforce variations with yaw, and now we can see the most likely cause of the asymmetry in the data. In positive yaw, rear downforce did actually go up with increasing yaw up to 5°, where it levelled off. In negative yaw, rear downforce was fairly steady at small angles but then reduced at 10° and 20° yaw, although only by about 5N relative to zero yaw.

So it seems likely that the step decrease in rear downforce at 10° negative yaw probably led to a mechanical rather than aerodynamic increase at the front at the same yaw angle.

But why should rear downforce respond differently? Perhaps because in positive yaw the large radiator and cowl on the right side of the car was increasingly in the lee of the car's central chassis and body, therefore lessening its negative downstream disruption, whereas in negative yaw the radiator and cowl became increasingly exposed to the airflow, which would increasingly disrupt flow to the rear wing.

WINDWARD HO!

Finally, let's return to the apparent reduction in drag force as yaw increased. Again the observant will have noticed that the axis of measurement of drag forces is parallel to the car's

longitudinal axis, and that this rotates with the turntable in MIRA's wind tunnel. Therefore, relative to the direction of the wind, drag measurement goes 'off axis' as yaw angle is applied. However, if we combine the side forces (shown in **Figure 7**) with the drag forces using Pythagoras' Theorem (the square root of the sum of the squares) the plot in **Figure 8** arises, showing the net forces in the direction of the airflow with increasing yaw angle. And overall it seems to fit what we might expect, with differences down to car asymmetry.

Next month we'll turn our attentions to a new project - the Praga R1.

Racecar Engineering's thanks to the staff and students at the University of Hertfordshire Formula Student Racing Team



In positive yaw, rear downforce increased with additional yaw up to 5°. In negative yaw, it was steady at small angles, but reduced at 10° and 20°

We bring the simulator You bring the models

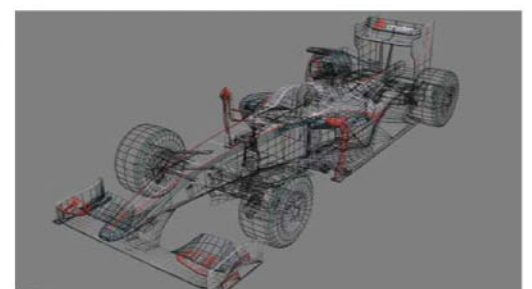

The most sophisticated 'off the shelf' full-motion professional simulator is now completely accessible using any vehicle modelling package that supports Simulink interfacing.

With ePhyse Net, race teams can run their own unmodified vehicle models with Cruden simulators on their own PCs natively, in co-simulation.

No compiling code. No need for Real Time Workshop. Simple.

We also still offer our own fully open Simulink Vehicle Model (CSVM) and can integrate customer MATLAB/Simulink-based models.

Find out more - www.cruden.com/motorsport/

Tunnel revision

Formula 1 relies heavily on wind tunnel testing, but there is much that cannot be replicated. Here's a short description of its limitations

BY MARCO DE LUCA

Rules say that the car model should have a scale ratio not greater than 60 per cent - including severe limitations of the motion-capability of its parts

The first full-scale wind tunnel at Langley Field was used to develop the Brewster Buffalo



While ago I was involved in a discussion with a friend who was absolutely convinced that all the resources devoted to the aero development of an F1 car - in terms of wind tunnel testing and computational simulation - were more than enough to create a 'perfect equivalent environment', where all the real phenomena would be simulated with an irrelevant gap of realism.

'No mate, this is not true I'm afraid,' was my answer. As a consequence, I was invited to justify my assertion by listing and commenting on the major sources of misalignment with reality, lots of them having no hope at all of closing the gap because of the nature of the tool we are talking about.

Fortunately, my friend's technical background helped, but to be honest I'm still not sure if I was brave enough to convince him that the final compromise the sport has arrived at works fine!

For the purposes of this article, I'll limit the discussion to activities in the wind tunnel only. The gaps of realism I'll detail here certainly do not represent an exhaustive list, but it is already quite impressive if you will consider the huge efforts in terms of people, infrastructure and budget that is necessary to stay competitive in terms of aero in modern F1 racing.

TESTING TIMES

Before proceeding, let's briefly summarise what's behind a typical F1 tunnel test, together with the main regulation limits that now govern the aerodynamic development as part of the official sports ruling body.

For some years now, in fact, the federation and teams agreed to respect a so-called Resource Restriction Agreement (RRA), the aim of which is to control the escalation in costs that - as far as the aerodynamics development is concerned - is basically driven by two aspects: a) the high-level technical research aimed at pushing to the extreme the realism of both wind tunnel and computational fluid dynamics exercises, and b) the maximisation of both testing and calculation 'productivity'.

Concerning tunnel testing, RRA gives restriction in terms of tunnel and model technology, and limits the testing time. The car's performance is inevitably directly linked to both.

Rules say that the car model should have a scale ratio not greater than 60 per cent, including severe limitations in terms of the motion-capability of its parts. Model change, say from one car spec to another, is also regulated in terms of frequency, alongside the obligation of having only one model present in the testing room.

Furthermore, the F1 tunnel cannot be pressurised (in terms of atmospheric pressure), and the air is the only permitted fluid with free-stream speed limited to 50m/s. Finally, in a given observation period, the weekly-averaged 'production' is restricted to a maximum of 80 runs, together with the obligation of

The Caterham F1 engine - thermal effects on the car and track are impossible to replicate

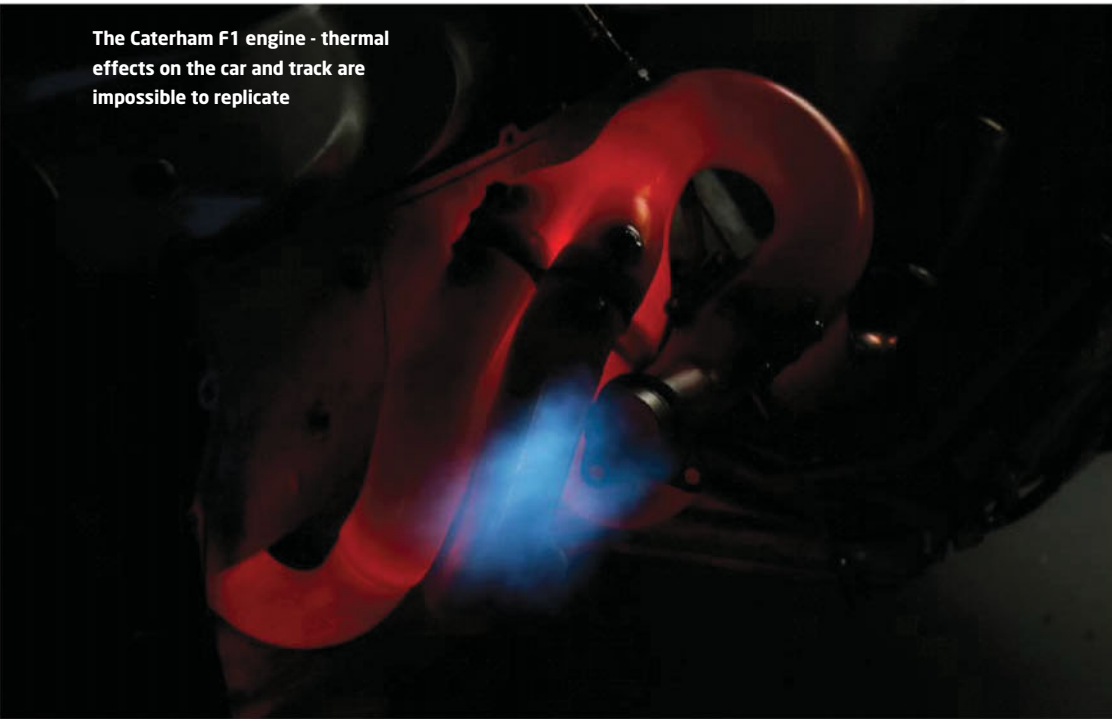

not exceeding 60 hours of tunnel occupancy. On top of these two limits, the max cumulative 'wind on' time also depends on how many CFD runs are completed in parallel: a specific algorithm indicates the limits for both wind tunnel and CFD activities as a function of how the respective productions progress in the given period.

To be open with you, with my engineer hat on, I was always quite sad when RRA was originally introduced and progressively exacerbated. I can remember the exciting attempts to increase the Reynolds number by increasing the fluid density (late-1980s: testing in a water basin; mid-1990s: construction of a wind tunnel capable of being pressurised). I cannot forget all the evaluations for a new generation wind tunnel with a very long testing chamber able to host two models for simulating tow conditions on-demand. I also struggled to abandon the studies of sophisticated mechanics and the associated control systems to be installed inside the scaled-down model in order to move its parts while blowing - driver's helmet included! And how can I forget the never-ending discussions with my colleagues on heating our radiators and brake disc replicas, or how we performed model changes fast in order to rotate more than one car model

during the same test day in the name of 'projects parallelisation'. Before the RRA introduction, we also used to easily blow at 70m/s or even more, and full-scale testing - real car in a huge tunnel - was also occasionally performed. Last but not least, managing two or three wind tunnels at the same time, working day and night, was not an unusual habit for a big team to push the 'aero productivity' in a constraints-free regime.

But in my experience as an F1 manager, I had to admit that some limits had to be eventually imposed to my community in order to avoid financial suicide, and to try to increase the chance of winning for those organisations with less aero people and reduced spending capability.

However, the points that follow are fundamentally independent of any restriction - ie they stay intimately linked to the limits of the model represented by a realistic/sustainable tunnel testing process that is adopted to develop the aerodynamics of a highly competitive racing car as for F1. But it is also true that, as the new RRA (effective January 2014) is

much more severe than before - ie fewer runs available - tunnel experiments have to become much more 'robust' than in the past in order to almost null the risk of losing any single run. The hope is that this new testing scenario would contribute to discouraging the adoption of extreme/unstable - not to mention very expensive - technology and methodology.

Tunnel testing is generally carried out at a fixed wind speed. This is somehow compulsory, because the reduced dimensions of the model are already a severe limiting factor in terms of how similar the experimental flow field can get to the real one. The wind speed is the only permitted parameter to compensate, but is now severely limited. One of the prices to pay for fixed-speed testing is that any changes of aero mechanisms linked to the variation of Reynolds is not correctly captured. The Reynolds (AKA Re) number - a not-dimensional figure directly proportional to speed multiplied by fluid-density and length, and inversely proportional to viscosity - basically represents

the ratio between inertia forces and viscosity effects acting on a body by the surrounding fluid. For a given geometry, two fluid environments are physically similar if - but not only if - their correspondent Re-numbers are equal. At least, the two Reynolds have to be higher than a critical value above which some fundamental mechanisms would be similar. Racecars experience quite a large range of Re-numbers due to the speed variation they are exposed to, and this simply cannot be recreated in any tunnel testing where max Reynolds is 'just adequate' to cover most of strategic conditions.

This means that several Re-number dependent effects - such as boundary layer thickness, flow transition and separation - cannot be perfectly reproduced if one would like to precisely simulate all the racing conditions. Well-known 'tricks' exist, but they just give a partial solution and - admittedly - are not so easy to manage.

Still related to speed, all the effects linked to the inertia of the fluid affecting the car when its speed changes rapidly have to be considered. Think about the aggressive braking manoeuvres of a modern F1 car, during which the velocity quickly reduces by about 200kph - if not more - in less than a few seconds. While the car decelerates, the flow structures basically collide with the car, therefore altering the behaviour of delicate elements such as the rear wing and diffuser, compared to their steady-state behaviour. Something similar also happens laterally when the car experiences fast direction change.

Fast motion of the car body is another time-dependent condition that is quite difficult - although not impossible up to a certain level - to recreate during tunnel experiments. Think again about the heavy-braking manoeuvre: due to the sudden load transfer and the progressive loss of downforce, the car quickly pitches down and then its ride height decreases. Fluid inertia is behind very complex mechanisms able to dramatically change how, above all, the ground effect reacts to this transient with effects that cannot manifest correctly during a steady-state tunnel

Reduced dimensions of tunnel models are a limiting factor in terms of how similar experimental flow field can get to the real car



Intelligent control and distribution of battery power in a modern racing car.

PCM / PDU **POWERBOX** CONTROLLING POWER

HP 8440 -V2

Used in championship winning cars:

- Le Mans winner LMP1, 2008-2013
- ALMS winning Porsche RS Spyder's
- Ferrari 458 GT2, BTTC and more...

Main Features:

- Maximum 200 Ampere continuous.
- 34 individually programmable output channels.
- Operated by 11 conventional, 32 CAN channels and by 20 virtual channels.
- Weight 710 gr.

1,399 €

Excl. VAT

Software included
Free upgrade

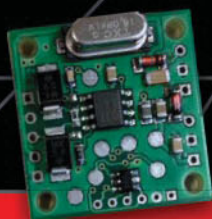

Analog to CAN converter
4 x Analog inputs to CAN.
Board size 24x24mm.
OEM board for your application.



8 x Tyre temperature
to CAN in one small
unit. Measure 8 points on
your Tyre - Transmit CAN to
Logger / Dashboard

OUR IDEA, DESIGN AND PRODUCTION



HP ELECTRONIK

Virkelyst 10 · Gjellerup
7400 Herning · Denmark

Tel. + 45 9626 4333
Fax + 45 9626 4233

info@hpelec.dk
www.hpelec.dk

PMU RACING

WINS!

In just a short time, PMU Racing brake pads have chalked up an impressive list of victories in most major international categories.

Whether your racing Sprint, Rally or Endurance discover the PMU racing advantage today... before your competition does.

WTCC, BTCC, NASCAR, ALMS, V8SUPERCARS, PORSCHE, DUBAI 24 HRS, VLN SERIES



Carbon Metallic (Sprint) & Sintered Metal (Endurance)
compounds available

**RACER
INDUSTRIES**

GLOBAL DISTRIBUTION CENTRE

Racer Industries +61 7 5591 8198 sales@pmuracing.com
286 Southport Nerang Road, Southport, Queensland AUSTRALIA

INTERNATIONAL DISTRIBUTORS LIST:

USA NASCAR/Sportscar
USA West Coast
United Kingdom
United Kingdom
Germany
Belgium
Italy
South Africa
New Zealand

Pro Systems - Mooresville NC - www.prosystembrakes.com
Mackin Industries - Santa Fe Springs CA - www.mackinindustries.com
Questmead - Lancashire UK - www.questmead.co.uk
Roll Centre Racing - Cambridge UK - www.rollcentre.co.uk
Leit Speed - München DE - www.leitspeed.de
Mosa Frein - Namur BE - www.mosa-frein.be
Tecnauto - Milano IT - www.tecnautosrl.com
VMP Motorsport CC - Maraisburg SA - www.vmpmotorsport.co.za
Hewlett Motorsport - Christchurch NZ - jhewlett@xtra.co.nz

P.MU Racing, the worlds finest motorsport brake pads are now available
through our global distribution network.

Contact your local distributor to experience the PMU Advantage for yourself.

www.pmuracing.com

The **PMU RACING** Advantage

Unrivalled stopping power

Outstanding fade resistance

Industry leading modulation
& 'release' characteristics

Low rotor wear

WorldMags.net



Paul Di Resta in the 2011 Force India, catching a slide under braking - almost impossible to simulate in the wind tunnel

experiment. Again, similar effects can be found in other manoeuvres like the rapid direction changes that cause fast rolling of the car chassis, fast change of suspension kinematics and fast tyre deformation.

Car vibration belongs to the category of time-dependent phenomena, and it is constantly experienced while lapping. I'm sure that most of you have had occasion to look at impressive ultra-slow motion videos of an F1 car, from which it should be evident how both the sprung and the unsprung parts of the car oscillate with a given frequency. These fixed-frequency motions are governed by the mass-springness coupling that makes each structure react to any external inputs - like kerbs, bumps, indeed any load-transfer - by cycling displacement. The aero is influenced by these parts motions that periodically alter the angle of attack and modify the volume at fluid disposal while wetting the car (floor-to-ground 'air layer', above all).

Car component deflection is a challenging item as well, and is important to better understand the real load-dependent aero behaviour of strategic components. F1 car components are stiff by regulation, but they cannot be infinitely stiff, hence items such as the front and rear wings, floor plate, thin devices and body panels inevitably deform under load.

Deflections are functions of aero forces, and so they fundamentally depend on car

speed and/or ride heights. For this to have a correct correspondence during tunnel testing, one should - in theory - design each model part with proper flexibility and go for wind-speed modulation. For the reasons I've described about wind-speed, coupled with design and production issues, this is a strategy that is not generally followed if compared to a 'stiffness-controlled' scaled-down model as reference.

Tyres are, by far, the car units with the greatest ability to deform with massive impact to aero if they're not properly managed. I delved into this subject in some detail for *Racecar* last year, in an article which can be summarised as follows... Modern rubber-made tunnel tyres are much better than the old spec in terms of realism, but the community still struggles to make them deform correctly, above all for cornering simulation, due to the lack of proper force-generation at tyre contact-patch coupled with the need to ensure high durability.

In short, transients affecting geometry stability are, unfortunately, abundantly present during a lap of an F1 car. And they cannot all be adequately reproduced because a) production

implications are too severe, b) tunnel testing is basically carried out at fixed speed, c) robotic systems - governing the positioning of the model by synchronising yaw-roll-pitch-rides-steer degrees of freedom - have limited capabilities, and d) filtering out the inertia forces that are huge and superimposed to the aero components to be finally discerned is a very, very challenging task.

The new 2014 aero rules, with increased structural constraints and reduced aero complexity, will improve the situation that, admittedly, became too extreme. This will also help to accept the limitations of a 'stiff' model. Tyres excluded!

Another extremely important category when talking about the differences between wind tunnel and track, is dealing with weather conditions. Forget any rain simulation, and forget any serious attempts to generate realistic variable wind condition. Instead, effects of steady side-wind with moderate lateral components may be studied by generating modest model-to-wind flow angle, provided the consequences of a not realistic boundary layer profile on the ground are known and carefully considered. But as soon

as the wind-angularity increases, the limitations imposed by the wind tunnel are severe enough that one risks generating a flow field that is dissimilar to reality. So dissimilar that it risks directing the car's aero development in the wrong direction.

Still related to weather, the effect of surface temperature is important to be simulated as well. As you well know, solar heating increases the temperature of both the car surfaces and - more severely - that of the tarmac due to its high heat-specific value. If compared to a cold/controlled condition of a typical F1 wind tunnel - hence, let me say, closer to calm winter day-test conditions - this real situation that's so frequently experienced in summertime races generates local flow structures that may modify the aerodynamics quite sensibly. The elements working on ground effect (front wing, floor) are quite sensitive to this thermal effect. In my experience, any attempts to recreate this effect in tunnel environments have a limited chance of succeeding.

The car itself heats up, primarily the tyres - of the order of 100degC at surface - and to the bodywork panels in proximity of engine and gearbox. Overheating scaled-down tyres has to be completely avoided in order to ensure problem-free tunnel testing, while heating bodywork surface is possible in theory, but would be quite limiting in terms of development rate and - in all honesty - not strategic at the end.

The so-called 'internal aerodynamics' is another difficult task. Let's start from powertrain cooling: in a real F1 car, the air crossing the heat exchangers gets quite hot due to the high heat to dissipate - lots of horsepower to wheels, lots of lost power to air. This hot mass flow-rate, the temperature of which is in the order of 100degC once leaving the rad-matrix at 'standard' ambient temp - exits at the back with no negligible effects to the rear aerodynamics if compared to cold condition. A secondary effect to consider is the variation of the heat exchange rate during the lap: in theory, any single car manoeuvre should be simulated with the

Overheating the scaled-down tyres has to be completely avoided in order to ensure problem-free tunnel testing





CRP GROUP

the experience of more than 40 years in the world of F1 racing and the in-depth knowledge of specific application fields

CRP TECHNOLOGY,

Modena, Italy
Advanced 3D Printing for High-Technology Applications and high performance composite materials for the 3D Printing process under the WINDFORM™ tradename.

CRP MECCANICA

and **CRP ENGINEERING**

Modena, Italy
High Precision CNC Machining and a team of highly-skilled engineers, experts in high-performance tailor-made designs under extreme confidentiality.

CRP USA

Mooresville, North Carolina
3D Printing and WINDFORM™ materials.

Using these technologies and know-how, **CRP** designs and produces sophisticated electric motorcycles, taking also advantage of suppliers from every corner of the world.



Fingerprint of quality.

HS CNC MACHINING

WINDFORM® 3D PRINTING

ENGINEERING



www.crp.eu | www.crp-usa.net | info@crp.eu | info@crp-usa.net

WorldMags.net

right level of heat transferred to the cooling air. Now, the adoption of replica radiators able to be heated by a controlled power-source is a legitimate exercise and - in principle - comparable to wind tunnel testing. But I would invite all of you to do a quick evaluation about the power involved to realistically heat the exchangers, and to also imagine all the practical issues that this methodology would imply.

Also note that any heat-exchanger replicas present inside the scaled-down model should also adapt their level of porosity as a function of the speed of the real car which is being simulated. This is theoretically needed to ensure the similarity of the two environments, only one of which is under constant speed. But in the end, the porosity - the internal flow rate for a given coupling between car configuration and manoeuvre - stays fixed at the level selected by aerodynamicists to better match the most important racing condition to be referred to while developing the car. This is a good compromise.

Similar considerations are valid for the braking units (disc and pad replicas) too, the temperature of which can easily reach several hundreds of degC very, very rapidly. And here again, hopes to even partially simulate this phenomena during tunnel experiments are almost non-existent. It is a pity, because as you may easily see on an F1 car, the aero development around the four wheel compartments is quite detailed and sophisticated due to their important contribution to the generation of the aero forces. The lack of realism related to air temp increase is not insignificant. Also, the wakes generated by the tyres is partially altered once very hot air is injected into it while braking - this effect is lost too.

Still on internal aero, let's briefly talk about the strategic capability of simulating the physics of exhaust gases as much as possible. In the last few years, the community I belong to learned very well how limiting the gap of realism was, in terms of gas temperature (diffusion, density, etc) and 'pulsing' effects due to the cycling of the real engine. While these two effects



Wet weather simulation is not an option in the wind tunnel

are constantly present and time-dependently combined in reality, they are basically missed during tunnel testing. Important resources were devoted to try to close the gap but, I admit, they only gave partial results. Fortunately, the 2014 rules will help to divert a great part of these resources somewhere else due to the prescribed position of a unique exhaust at the back, far from floor and wings, hence with very reduced possibility to give positive aero contribution.

But is the cornering condition that is at the top of the wish-list of any aerodynamicist who really knows where the realism should be improved to be competitive. What follows should also clarify the fact that wind tunnel experiments were originally born to support the development of 'clean aerodynamics' flying vehicles - with emphasis on their steady-state cruise mission segment - and then extended to commercial surface vehicles (with all the implications dictated by being close to one of the tunnel walls), then 'forced' to deal with racecar development. Modern F1 car missions and conventional wind tunnel technology are really quite distant from one another.

My colleagues know very well how hard the process was - and still is - to constantly adapt and

improve our tunnels to stay competitive in this business.

While negotiating steady state cornering, the wind direction experienced by the car is not null if referred to its longitudinal axis. Also, the wind incidence increases going from nose to tail. This modulation of the angle of attack is the primary function of the cornering radius and velocity. During fast cornering (high radius, small steering-angle), the wind always comes from the same direction, that is, the external side of the turn. Below a certain speed, instead, the front and rear ends have opposed wind directions, with the front end experiencing incidence from the 'inside'.

It should now be evident that no solution exists to perfectly replicate these conditions in a classic wind tunnel environment, where the principle of reversing the physics (fixed model/air in motion) 'works' for pure straight-line condition only. If, up to the 1990s this need was somehow ignored - partly because of the greater importance of straight lines compared to today's circuits - nowadays lots of sophisticated tricks try to offer the best compromise ever to better develop the aerodynamics for cornering conditions. But a 'perfect solution' will never exist.

Many other sources of poor realism deserve to be listed and commented upon here, such as the well-known 'blockage effect' imposed by tunnel walls, the intrusiveness of the model supports, the reduced dimension of the running belt together with its unrealistic surface (often too smooth), the never-perfect flow-profile on top of it, the turbulence level of the air, the lack of any proximity with other car, the inability to perfectly capture the aero forces of the wheel units... But my room ends here, I'm afraid!

So, in conclusion, why is the wind tunnel still a strategic tool for a winning F1 car that justifies such an enormous drain on resources? Well, first of all this was an unfair feature: the pros associated to wind tunnel testing - starting from benefit/cost ratio if compared to other development tools - are massive and a dedicated article in favour of tunnels would be equally long and passionate. Just let me say that tunnel experiment is a simplification of reality. Having to deal with the complex and delicate aero of an F1 car, a tool that is always able to go back to fundamentals and to test the validity of the designer's ideas offering quick feedback for lots of combinations between configuration and manoeuvres, is a genuine strategic help.

But, please, never forget that the tool we're talking about here is a model, and it has to be treated consistently with its nature and limitations. A book quite famous among insiders says that the wind tunnel is nothing more than an analogical computer trying to simulate the reality. A wise statement!

Finally, as I had occasion to mention in the past, CFD and track tests (despite the latter being still too limited!) are able to integrate what the tunnel cannot say. The synergy between these three environments is the key to successful aero development in high level motor racing.

Nowadays, if the aero of a modern F1 was only based on tunnel testing, it simply wouldn't be competitive, independently of all the efforts anyone could imagine to have the most advanced and realistic tunnel in the world at their disposal. 

The cornering condition is at the top of the wish-list of any aerodynamicist who knows where the realism should be improved



Sensor-Technik UK Ltd.

Mobile Controllers and Measurement Technologies

Sensor-Technik UK Pressure Sensors

- ▶ Measuring up to 3,000 bar
- ▶ Versatile, low failure rates
- ▶ Thin-film, ceramic or silicon available

Delivering An Integrated Solution

- ▶ Sensor & Measuring Systems
- ▶ Controllers & HMIs
- ▶ Complete Engineering Lifecycle



A08 Pressure Sensor

- ▶ Varied media compatibility
- ▶ 0-1000 Bar Range



NGS1 Inclinatio/Gyrosensor

- ▶ Measuring Range $\pm 90^\circ$
- ▶ CANOpen Output Signal



M01 Pressure Sensor

- ▶ Off-highway vehicles
- ▶ 0-800 Bar Range



L03 Pressure Sensor

- ▶ Food Industry
- ▶ 0-20 bar range

www.sensor-technik.co.uk
sales@sensor-technik.co.uk

Sensor-Technik UK

Unit 21M, Bedford Heights, Bedford, MK41 7PH

Tel: 01234 270770 | Fax: 01234 348803

Your Ideas. Realised
Your Ideas. Realised

Motorsport. Redefined.

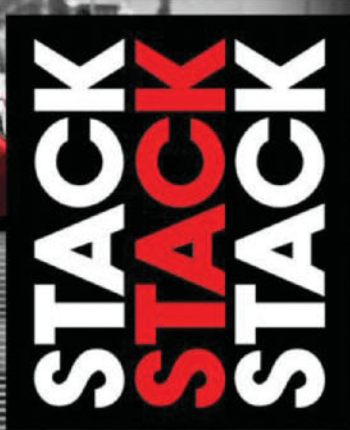

The STACK LCD Motorsport Display is the next evolution of driver communication and data acquisition. Designed specifically for the harshest of environments, the carbon composite housing is IP67 sealed against water and dust intrusion and will easily withstand 20 g of continuous vibration and 50 g of shock. Our 7" LCD panel ensures easy visibility under all circumstances with a retina level pixel density, unmatched brightness and an optically bonded lens for extreme glare suppression. The display layout is fully configurable to your individual specifications. The system will accomodate four programmable data bus channels (2 CAN and 2 serial) in conjunction with a nearly limitless amount of discrete analog sensors and its integrated 3 Axis Accelerometer. Data collection can occur at up to 1 kHz and the internal memory allows for practically infinite recording time. User defininable warnings take advantage of super bright, multi-coloured LEDs placed around the perimeter of the chassis to alert the driver to critical onscreen information. Quite simply, everything else suddenly seems a bit dated.

STACKLTD.COM

©2014 Stack Ltd.

Efficient cooling

With the arrival of the new generation of F1 engines, a host of energy recovery solutions are on the cards. But could refrigeration also be factored into such a system without compromising performance?

BY ANDREW MARINA

The previous generation of Formula 1 engines, introduced at the beginning of the 2006 season, consisted of 2.4-litre, 90-degree naturally aspirated V8 configuration with a speed limit of 18,000rpm. With the aim of making the sport of Formula 1 more relevant to the road car industry, this generation of engines was set to be superseded by units with increased efficiency and a heavy focus on energy recovery technologies. For 2014, a 1.6-litre, direct injection V6 with a maximum speed of 15,000rpm will be utilised. Furthermore, a restriction will be placed on the maximum fuel flow rate, placing further emphasis on efficiency.

In order to maintain the power of the current engines with a reduced displacement volume and lower maximum speed, the use of a single turbocharger has been allowed. A turbocharger is a device which is able to increase the intake air density allowing for more fuel to be burnt in the engine per cycle. Taken from John B Heywood's Internal Combustion Engine Fundamentals, **Equations 1 and 2** show that the power and torque that can be produced by an engine is proportional to the air mass induced per cycle, and so increasing the density

NOMENCLATURE

A/R	Area to radius ratio turbine	in
BSFC	Brake specific fuel consumption	g/kWhr
F/A	Fuel to air mass ratio	(-)
MGU-H	Motor generator unit - heat	(-)
MGU-K	Motor generator unit - kinetic	(-)
N	Engine speed	RPS, RPM
P	Power	kW
Q _{HV}	Heating value of fuel	kJ/kg
r	Compression ratio	(-)
T	Torque	Nm
V _D	Displacement volume	m ³
η _f	Fuel conversion efficiency	(-)
η _{th}	Thermal efficiency	(-)
η _v	Volumetric efficiency	(-)
γ	Ratio of specific heats	(-)
ρ _{a,i}	Density air intake	kg/m ³

can lead to increases in both the power and torque. The intake air is compressed by means of a centrifugal compressor, which is powered by the exhaust gases.

The use of a turbocharger can provide two benefits in terms of engine performance - higher power density and reductions in the specific fuel consumption. Furthermore, engines with a smaller displacement volume that can match the maximum power output of a larger capacity engine will achieve better fuel economy at part load.

Despite the benefits that turbochargers provide, there are limitations to their use. The rotational speed of the turbocharger is generally matched to a particular engine operating condition or a speed and load combination. It is suggested that achieving sufficient performance at other operating conditions is challenging. This issue has been overcome in the 2014 F1 engine specifications through the use of a motor generator unit (MGU-H) which is able to both recover exhaust energy for storage, or alternatively, power the compressor for increased mass flow of charge air and hence torque at lower engine speeds.

Additionally, compression of the charge intake results in increases in the density and temperature of the air at the inlet to the engine. When utilising the correct air-fuel ratio, this may result in high in-cylinder pressures and temperatures. These phenomena can lead to pre-ignition or knock in the engine whereby the fuel is ignited before the spark plug is activated. Due to the increase in the air temperature as it is compressed, the pressure ratio that can be achieved through compression by the turbocharger is limited due to knock damaging the engine. Variables which are adjusted in order to limit the likelihood of knock in a turbocharged engine are compression ratio, spark timing, charge air temperature and air-fuel ratio (AFR).

The theoretical maximum thermal efficiency of an internal combustion engine is limited by the compression ratio as can be seen in **Equation 3**. The maximum theoretical thermal efficiency that can be achieved by an engine for various compression ratios can be seen in **Figure 1**. It can be seen that increasing the compression ratio leads to limiting gains in the thermal efficiency.

A standard method for dealing with pre-ignition in engines is to reduce the compression ratio despite the subsequent loss in thermal efficiency, as the power output will be greater than that of the normally aspirated engine.

The inlet charge air temperature also has a large

Equation 1: power of internal combustion engine

$$P = \frac{\eta_f \eta_v N V_d Q_{HV} \rho_{a,i} (F/A)}{2}$$

Equation 2: torque of internal combustion engine

$$T = \frac{\eta_f \eta_v V_d Q_{HV} \rho_{a,i} (F/A)}{4\pi}$$

Equation 3: theoretical maximum thermal efficiency of an internal combustion engine

$$\eta_{th} = 1 - \frac{1}{r^{\gamma-1}}$$

While not permitted by the current F1 regulations, this theoretical study was conducted to show the benefits and drawbacks of a refrigeration system

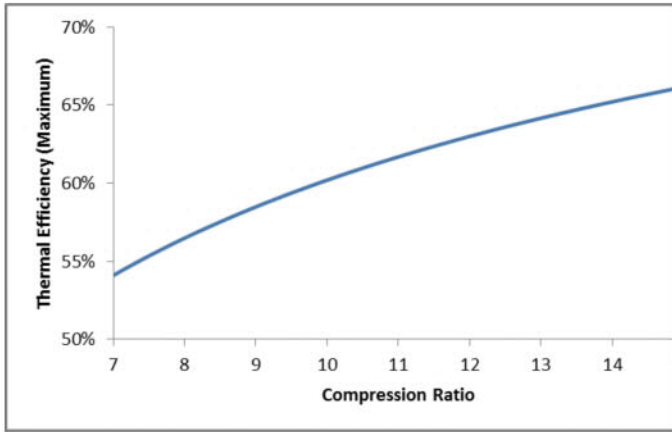

Figure 1: theoretical max thermal efficiency of an internal combustion engine

TABLE 1: ENGINE SPECIFICATIONS

Parameter	Value	Unit
Configuration	V6	(-)
Displacement	1.6	L
Speed limit	15,000	RPM
Plenum volume	1.6	L
Bore	80	mm
Stroke	53	mm
Valves	24	(-)
Fuel consumption (max)	$0.009N(RPM)+5.5$ or 100	kg/hr

influence on the allowable boost level. Sufficiently lowering the charge air temperature ensures that the likelihood of detonation is reduced, allowing increases in the compression ratio of the engine. This leads to direct improvements in the thermal efficiency of the engine and therefore the power- and brake-specific fuel consumption (BSFC). Cooling of the charge air is typically conducted through the use of an air-to-air heat exchanger known as an intercooler.

A further benefit of charge air cooling is an increase in the charge air density, with only a small loss in the pressure. The increase in density, and the favourable pressure ratio over the valves, will result in increases in the volumetric efficiency of the engine, leading to further increases in the power that can be produced.

REFRIGERATION SYSTEM

For the purpose of an individual thesis project for an MSc in Motorsport Engineering and Management at Cranfield University, it was proposed that through utilising a vapour compression refrigeration system powered by exhaust energy, it is possible to reduce the temperature

of the charge air to a level that is below ambient conditions, or what could be achieved with a typical intercooler. The proposed system utilises excess energy generated from the MGU-H coupled to the turbocharger permitted by the 2014 F1 technical regulations. The regs allow energy to flow from a storage medium to and from two motor generator units. The second motor generator unit (MGU-K) is coupled to the driveshaft to give further vehicle performance when necessary. A study of the energy balance shows that the exhaust turbine can provide a maximum of 2MJ to the MGU-K every lap, which must be accounted for.

Contrasting with the configuration of a 2014 F1 engine (Figure 2), the proposed configuration of the engine and related system can be seen in Figure 3. The refrigeration system replaces the intercooler that would typically be present. The vapour compression refrigeration system consists of an energy consuming device (refrigerant compressor), as well as various heat exchangers which absorb heat from the charge air (evaporator) as well as rejecting this heat to the environment (condenser).

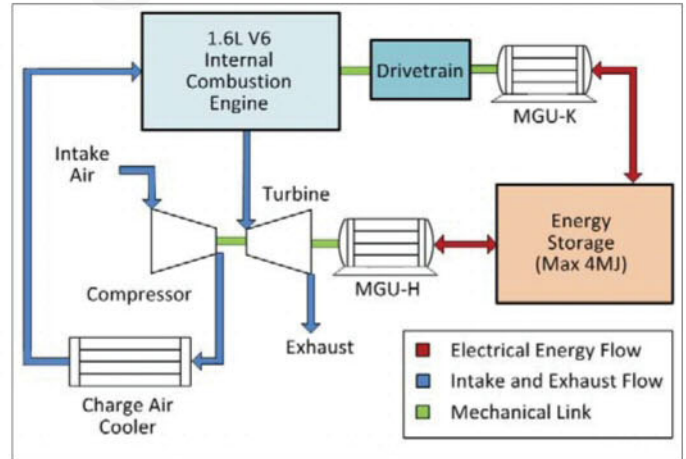

Figure 2: 2014 Formula 1 engine overview

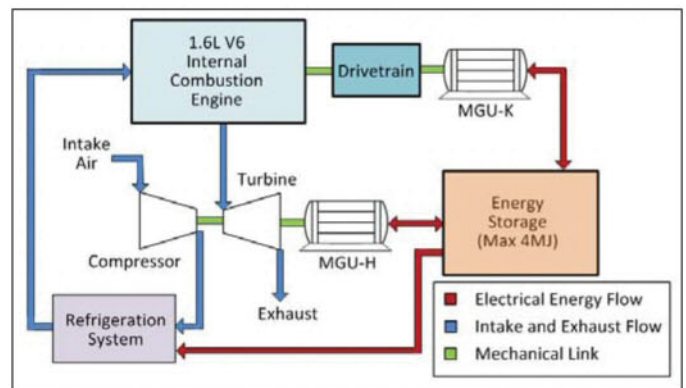

Figure 3: proposed configuration of new engine and related systems

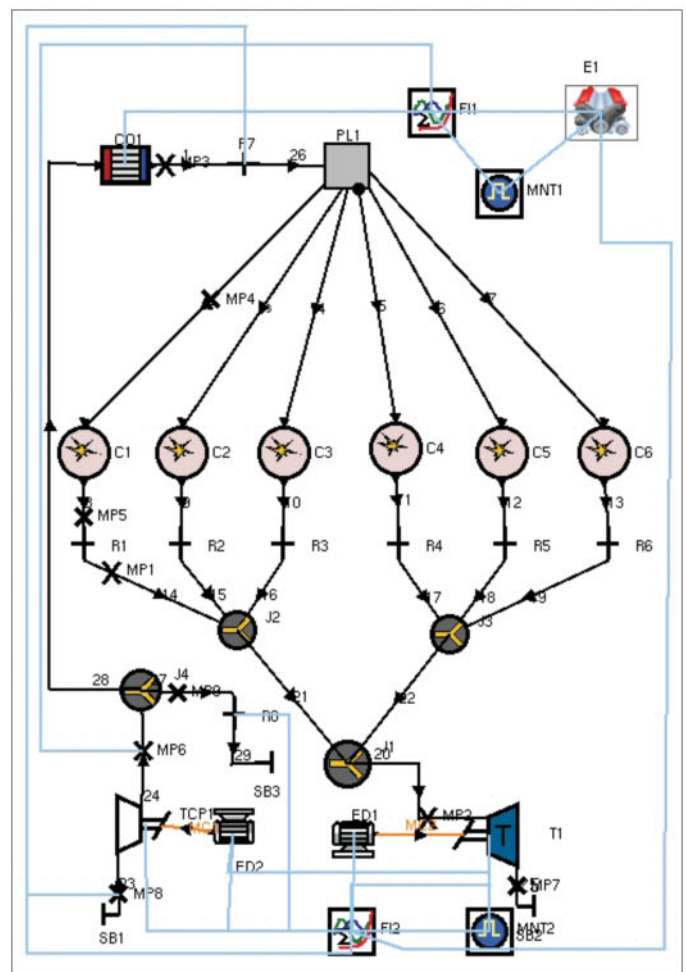

Figure 4: AVL Boost 2014 Formula 1 engine model

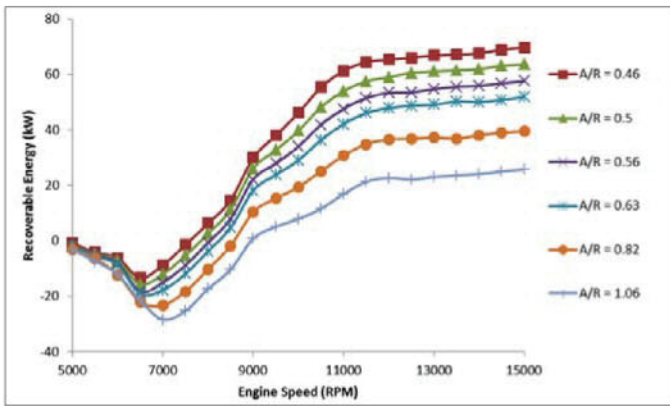

Figure 5: recoverable exhaust energy for turbines on a 2014 F1 engine

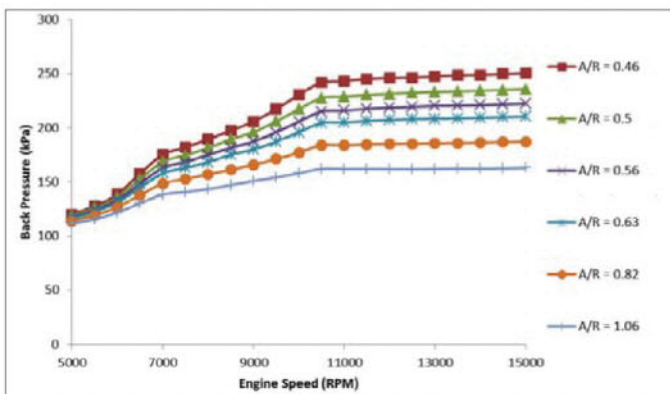

Figure 6: engine back pressure for different turbines on a 2014 F1 engine

While this system is not permitted by the current F1 technical regulations, the investigatory theoretical study has been conducted to show the benefits and drawbacks of such a system. The sections which follow outline the methodology and results of the study.

SYSTEM MODELLING

Simulation of the 2014 F1 engine was conducted with the commercially available AVL Boost software package. The engine was modelled utilising a number of elements available in the AVL pre-processor, as well as the inclusion of a number of control elements in order to account for the intercooler and MGU-H coupled to the turbocharger. The various parameters that of the model, based on the 2014 F1 regulations can be seen in **Table 1**.

The constructed AVL Boost model, incorporating the parameters of the 2014 F1 engine, can be seen in **Figure 4**. It is evident that the compressor and turbine of the turbocharger have been split, with each one connected to an electric motor unit. While the regulations permit the use of only one electric

device connected through a single shaft to the turbine and compressor, this configuration is able to mimic this behaviour. Speed matching the two electrical motor devices and utilising conservation of energy principles ensures that the two units give the same output as a solitary device connected to both the compressor and turbine.

As the purpose of the study was to determine the benefits of a refrigeration system, the engine was firstly required to be modelled with a conventional intercooler. It is evident that as the turbocharger boost and isentropic efficiency changes, as well as differing mass flow rates due to various engine speed, load conditions and vehicle velocity, the intercooler effectiveness will cease to be constant. Utilising heat exchanger correlations and theory, the performance - indicated by intercooler

There remained enough energy to supply 12kW to a refrigerant compressor for the purpose of charge air cooling

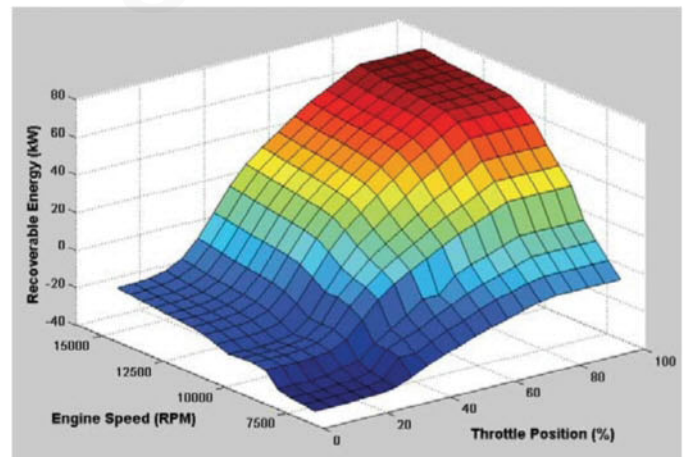

Figure 7: instantaneous recoverable exhaust energy as a function of engine speed and throttle position

effectiveness - was calculated at all engine speeds and boost pressure ratios. This data was input into the AVL Boost model.

The sizing of the correct compressor for the system was based on the maximum fuel flow rate, as opposed to the conventional method of specifying a target power output for the engine. The compressor operation points at all engine speeds were calculated utilising the appropriate theory at the maximum fuel mass flow rate. Various compressor maps were sourced from the turbocharger manufacturer Garrett for the purpose of selecting a suitable turbocharger for the application. It was found that no compressor existed which was able to provide the required air mass flow rate at all engine speeds to deliver the maximum fuel flow rate.

Despite this, the GTX3076R compressor contained the most operating points within the given compressor map and was utilised for the purpose of this study. It was evident from the calculations that at low engine speeds, the boost pressure of the compressor needs to be minimised in order to prevent the compressor going into surge, a region of instability which may lead to damage. This means that the maximum fuel flow rate is not able to be reached at low engine speeds.

AVL Boost allows for the calculation of the octane number required from the fuel in order to suppress knock in the engine. Current regulations limit the octane number of the fuel to 102 and as such this condition must be adhered to in the engine model. In order to adhere to this condition, the compression ratio was limited to 10 and the air-fuel ratio was reduced to 13.0.

One of the primary investigations of the study was the effect of changing the swallowing capacity of the turbine through variations in the inlet area and scroll radius, or - more specifically - the A/R ratio. Reducing the inlet area to the scroll of the turbine results in higher exhaust gas velocities entering the turbine, leading to increases in the response and engine power at lower engine speeds. Despite this, the maximum swallowing capacity of the turbine can be greatly reduced, leading to reductions in power at higher engine speeds. On the other hand, increasing the inlet area to the turbine will improve the swallowing capacity, with an associated lower engine back pressure and therefore greater power at higher engine speeds.

Five various turbine maps were input into the AVL Boost model and the engine simulated at full load to determine the effect of turbines with differing swallowing capacity characteristics on engine performance. **Figure 5** shows the recoverable exhaust energy that could be generated and stored from the various turbines. Negative values suggest that the compressor requires more power





WE'RE ON YOUR TEAM...

HIGH-PERFORMANCE CONNECTORS
FOR MOTORSPORT APPLICATIONS



MANUFACTURED BY
SOURIAU

ASSEMBLED & STOCKED IN THE UK BY
FC LANE ELECTRONICS LTD
WWW.LANEMOTORSPORT.COM MOTORSPORT@FCLANE.COM
TEL. +44 (0) 1403 790 661



ENGINEERING THE ADVANTAGE THROUGH QUALITY DESIGN

Our innovative design and precision performance engineering makes us your perfect Motorsport partner. Our world-class engineers are committed to delivering world class services where your exacting requirements will be mirrored by our exacting standards.

Contact us to see how we can engineer your competitive advantage.

T. +44 (0) 1480 474402
sales@titan.uk.net

www.titan.uk.net



Dynamic Engineering

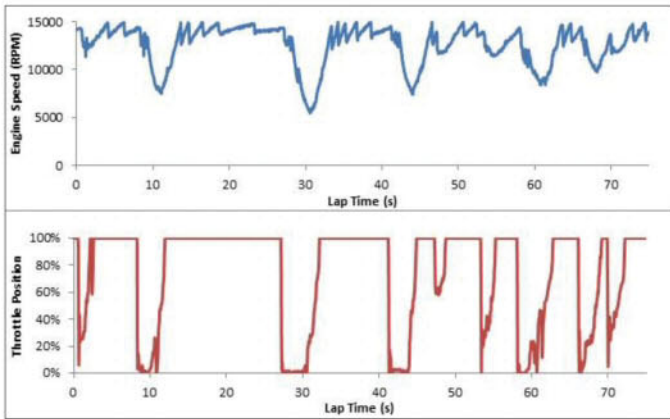

Figure 8: normalised engine speed and throttle position of F1 vehicle at Hockenheim (from Cosworth Electronics, Pi Toolbox, 2009)

than is produced by turbine which needs to be supplied from the energy store.

It was observed that reduction in the turbine A/R resulted in increases in the recoverable exhaust energy at all engine speeds. Meanwhile, the average increase in power that can be recovered over the range of engine speeds from an A/R of 1.06 to 0.46 was 29.5kW.

Despite the extra recoverable exhaust energy that is available through utilising a smaller turbine A/R ratio, **Figure 6** shows - as suggested in the relevant theory - that the back pressure on the engine is increased. Increase of the back pressure on the engine was noted to have two adverse effects on engine performance. Increasing the A/R ratio from 0.46 to 1.06 resulted in power increases of up to 14.5kW, or 4.8 per cent at 15,000rpm. For all engine speeds simulated, it was found that as the A/R ratio reduced, and the back pressure on the engine increased, the power produced by the engine would diminish.

A second detrimental effect was observed - as the back pressure on the engine increased, so too did the octane number of the fuel required to suppress knock. Utilising an A/R ratio of 1.06 required an octane number of 97.8, whereas a turbine with an A/R ratio of 0.46 required an octane number of 101.8.

The requirement to provide 2MJ of energy to the MGU-K - in addition to supplying electrical energy to the MGU-H when there are low levels of exhaust energy, as well as providing power for a charge air refrigeration system - indicated that the smallest A/R

ratio (0.46) turbine which provides the greatest potential for energy recovery should be utilised.

The next step in the engine model was to determine part load characteristics with the aim of determining recoverable exhaust energy at all engine speed and load combinations. A percentage of full load power was targeted, which corresponded to a particular throttle percentage through variation of flow coefficients of restrictors in the engine model. This was conducted for a range of engine speed and load combinations. A map of instantaneous energy recovery as a function of both throttle position and engine speed was generated as seen in **Figure 7**.

LAP SIMULATION

For the purpose of quantifying the likely energy recovery from an F1 engine that could be used for charge air cooling, data from a previous generation car at Hockenheim was sourced from the data acquisition and analysis software, Pi Toolbox. The engine speed data was scaled such that the maximum engine speed was normalised to 15,000rpm. The data can be seen in **Figure 8**. Combining the data from this with the map in **Figure 7**, the instantaneous power to/from the MGU-H could be estimated at all times over a lap. This data was integrated with respect to time in order to determine an estimate of the total recoverable

TABLE 2: SUMMARY OF RECOVERABLE EXHAUST ENERGY FROM HOCKENHEIM

Track	Hockenheim
Lap time (s)	77.52
Recoverable energy (MJ/lap)	2.92
MGU-K energy (MJ/lap)	2
Refrigeration system energy (MJ/lap)	0.92
Refrigeration system power (kW)	12

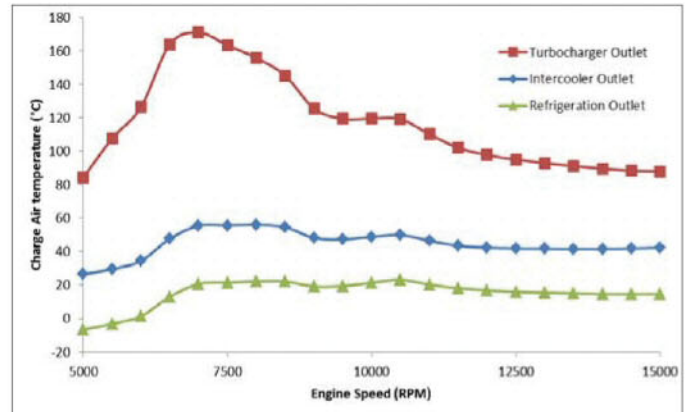

Figure 9: charge air temperature overview

exhaust energy over a lap of the Hockenheim circuit as summarised in **Table 2**. After accounting for both the MGU-H and MGU-K - as well as losses due to mechanical and electrical efficiencies in the system - there remained enough energy to supply 12kW to a refrigerant compressor for the purpose of charge air cooling.

Utilising refrigeration theory combined with heat exchanger principles and correlations, various refrigeration system designs were considered for cooling of the engine charge air intake. The focus of the design study involved minimising system heat exchanger sizes, while aiming to achieve charge air temperatures lower than ambient (25degC). The designed refrigeration system utilised the refrigerant R134a and could achieve a coefficient of performance of 2.8 based on data taken from the engine model at 8000rpm.

Based on the refrigeration system design, the minimum engine charge air temperature under steady state conditions was calculated at all engine speeds. This is indicated in **Figure 9**, with

a comparison provided to the temperature at the turbocharger compressor exit, as well as the temperature that could be achieved through conventional intercooling. It is immediately evident from this figure that the large reductions in charge air temperature are possible with both intercooling and the use of a refrigeration system. Under steady state conditions, it was found that replacing the intercooler with a refrigeration system could result in the charge air temperature being reduced between 25degC and 35degC depending on the engine speed conditions, with the temperature below ambient (25degC) under all conditions.

ENGINE PERFORMANCE

The charge air cooling data for the refrigeration system was input into the AVL Boost model. It was found that the compression ratio could be increased from 10 to 11 (10 per cent) before the limit where knock in the engine was reached. The performance of the engine utilising a vapour compression refrigeration system is compared with an intercooler for charge air cooling in **Figure 10**.

Further investigation of **Figure 10** appears to show positive outcomes in all the key performance indicators. It was

Charge air cooling increases the charge air density with only a small loss in the pressure



The Lightest, Most Flexible Hose and Fitting Combination Available!

USA North Carolina

704.793.4319
sales@bmrsusa.com

California NEW!

714.415.0080
socalsales@bmrsusa.com

UK Slough

01753.545554
sales@bmrsuk.com

www.bmrs.net



HEAT EXCHANGER SERVICES

Our ISO graded 'clean room' is available for complete core cleaning and particle cleanliness assessment on radiators, oil coolers and chargecoolers.

Core Cleaning

Ultrasonic, Power Flush, Pulsation, Agitation & Flow Bench

Particle Assessment

ISO 16232, Microscopic & Optical Analysis, Size & Count

Calorimetric, Flow & Pressure Testing

Radiators, Oil, Gearbox, KERs & Chargecoolers

Core Race Preparation

Cleaning, Filtration, Drying
Oil Conditioning and Sealing



www.youngcalibration.co.uk
+44 (0)1273 455572

Unit 4, Ham Business Centre, Brighton Road, Shoreham by Sea, BN43 6RE

determined that the engine which utilised the refrigeration system was able to produce a peak power of 396.4kW at 10,500rpm. This was an improvement in the peak power of the engine compared to conventional intercooling by 9.9kW or 2.6 per cent. The maximum torque of the engine was found to be 417Nm, an increase of 17Nm or 4.2 per cent over the intercooled model.

Finally, the minimum brake-specific fuel consumption (BSFC) - a measure of engine efficiency - was found to reduce by 7.2g/kW.hr or 3.1 per cent. Due to the fuel flow rate restriction of the engine, the improvements in the engine performance are limited. The improvements are attributed to the increase in the thermal efficiency as the compression ratio is increased. Only at low engine speeds are sizable performance benefits able to be achieved, as increases in the charge air density allows a higher mass flow of air to enter the engine without either the compressor going into surge conditions or the maximum fuel flow rate being reached.

While initial results suggest that there are performance benefits to running an F1 engine with a refrigeration system for charge air cooling, there are negative aspects to recovering high amounts of exhaust energy attributed to the subsequent higher back pressure on the engine. A further study was conducted using the intercooled model whereby the turbine A/R ratio was increased from 0.46 to 0.63 and the compression ratio was once again increased until 10.5, at which point further increases in the compression ratio would result in knock occurring in the engine. The performance of the engine utilising a vapour compression refrigeration system is compared with the modified engine model, utilising an intercooler for charge air cooling as seen in **Figure 11**.

As with the previous case, the increase in the charge air density allows a greater fuel flow rate and therefore greater power for engine speeds of 6500rpm and below, where boost pressure is limited by the compressor going into surge condition. It can be seen for the modified intercooled model

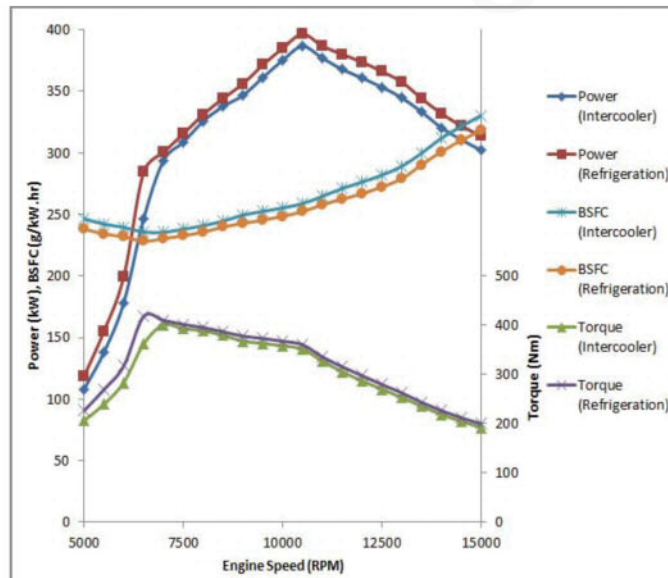

Figure 10: first look at a new F1 engine with various charge air cooling methods

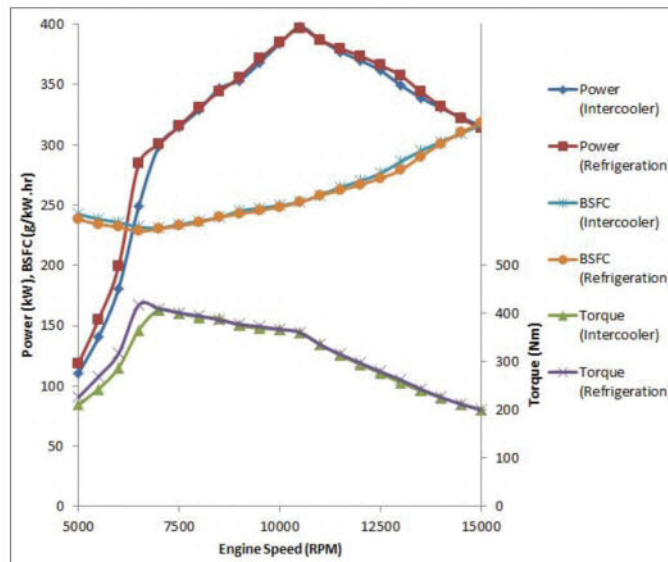

Figure 11: second comparison of the different charge air cooling methods

that the power, torque and BSFC are almost identical for engine speeds of 7000rpm and above. The maximum power, torque and BSFC deviation between the modified intercooled model and the refrigeration system model is 2.4 per cent at 13,000rpm. At all other engine speeds there is a maximum 1.5 per cent deviation. This is compared with the original intercooled model with the smaller turbine A/R ratio, where there is as much as 3.8 per cent deviation. The average improvement in power, torque and BSFC for the engine model

with the refrigeration system in the speed range of 7000rpm and above was 2.9 per cent over the original intercooled model. However, this was reduced to just a 0.7 per cent improvement for the modified case.

Based on the results of the simulations for the two intercooler models, it can be seen that utilising a turbine with a larger A/R ratio - and increasing the compression ratio to the limit whereby knock will occur in the engine - gives only a small increase in engine performance in the speed range from 7000-15,000rpm as the

system utilising refrigeration for charge air cooling. If this turbine with the larger A/R was able to generate the 2MJ of energy required by the MGU-K, it almost completely negates the performance gained by operating with the charge air cooling refrigeration system. This is due to the higher back pressure on the engine required to generate enough power for the refrigeration and other energy recovery systems, resulting in a direct reduction in engine power as well as limiting the compression ratio and therefore thermal efficiency that can be achieved.

CONCLUSIONS

The present study investigated the use of a vapour compression refrigeration system for charge air cooling of a turbocharged 2014 F1 engine powered solely through the recovery of exhaust energy. It was shown that through cooling the charge air temperature below ambient conditions - or that which can be achieved through a conventional intercooler - increases in the compression ratio could be made without the onset of knock occurring in the engine. This resulted in an increase to the power generated by the engine, attributed to increases in the thermal efficiency. Furthermore, at lower engine speeds, increases in the charge air density due to the lower temperature of the charge air allowed high air mass flow rates to be entrained into the engine without the compressor going into surge conditions.

The investigation also revealed that recovering a large amount of exhaust energy had negative performance aspects. Removal of the refrigeration system required the recovery of less exhaust energy, leading to a reduction in the back pressure on the engine. This resulted in a direct increase in the power as well as allowing the compression ratio and - therefore - thermal efficiency of the engine to be increased. Overall, the small performance benefit, combined with added mass, volume and complexity, suggests that there is little benefit in utilising a refrigeration system for charge air cooling powered solely through exhaust recovered energy.

We see that recovering a large amount of exhaust energy has negative performance aspects

MOCAL

OIL COOLERS

- **THE MOST POPULAR COMPONENT IN MOTORSPORT**
- **COMPREHENSIVE RANGE OF COOLING ACCESSORIES**
- **BRITISH DESIGN & MANUFACTURE**

FOR THE BEST IN OIL COOLING SYSTEMS...

...MAKE IT MOCAL!



WINNING RACES SINCE 1967

Worldwide enquiries go to:

www.mocal.co.uk

USA enquiries go to:

www.mocal.us

0208 232 3525



CD35

THE NEW DISPLAY FROM GEMS



> 5.7in sunlight readable TFT

> 9 tri-colour shift lights

> 24 configurable pages

> Integrated data-logging



www.gems.co.uk

Made to measure

Reventec's new motion position sensor can allow designers to assess parts in hostile environments

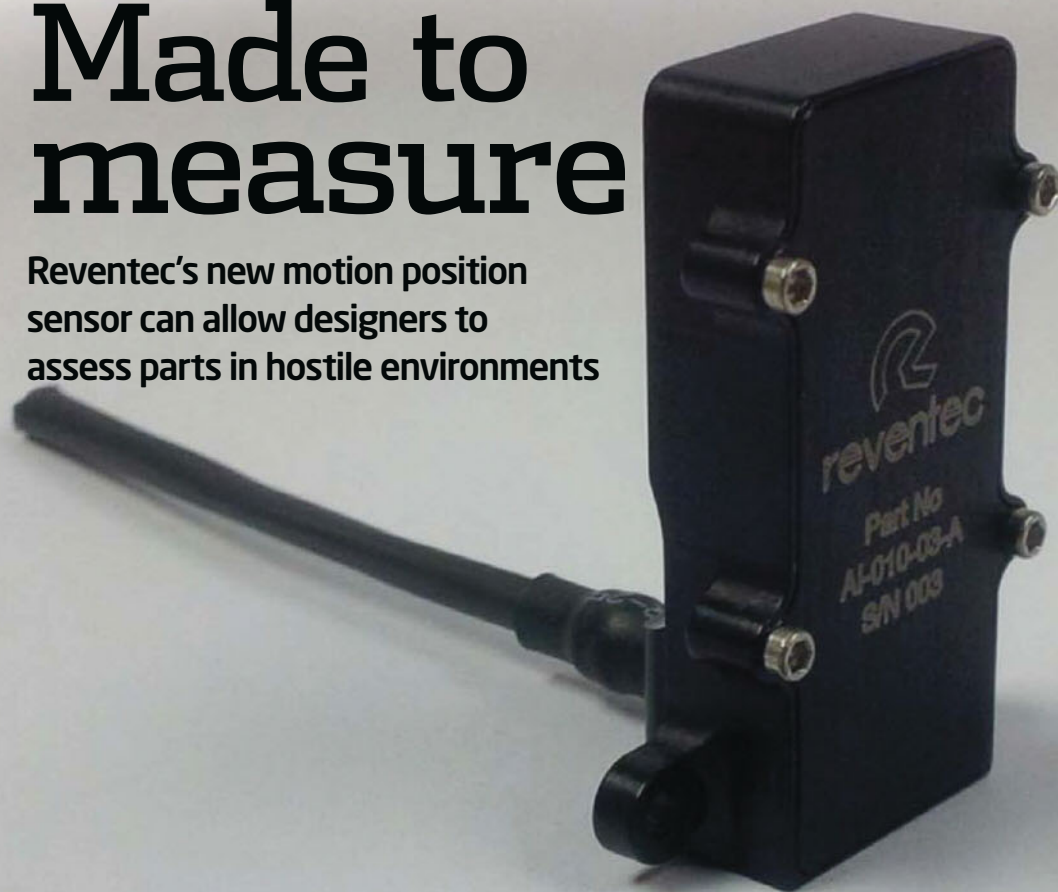

With the Reventec system, the electronics go outside the casing, while the 'target' - a magnet - can be embedded into confined areas

British electronics and sensor design experts Reventec has developed an all-new motion position sensor that not only works over a relatively large distance, 40mm, but also works through materials such as aluminium and carbon, making it a perfect solution for operating in hostile environments.

Started in the middle of 2013 by Neville Meech - a former Gill Sensors engineer with extensive motor racing experience in F1 and sportscar racing - the company has already started to deliver its sensor technology into Formula 1, starting with brake system and suspension applications.

'Initially, we developed a standard product, a 150mm position sensor which uses

BY ANDREW COTTON

magneto resistive [MR] technology,' says Meech. 'One of the key features of this technology is that it can detect a target across very wide gaps - up to 40mm - but more significantly it can also measure through most non-ferrous materials like stainless steel, aluminium and titanium. It is a function of the MR components themselves and the way that we are using it that has largely made this possible.'

Hall Effect technology can generally only detect across gaps

of up to approximately 6mm, and the combination of the increased range and ability to measure through certain metallic materials is very attractive to a lot of engineers and designers that are trying to measure moving parts in hostile environments.

'This is particularly the case in transmission or hydraulic systems, for example where you don't want to place delicate electronic systems in a hot, oily or high pressure environment,' says Meech. 'You can place the target - which is a magnet - in the hot oily environment, and position the

electronics on the outside of the casing, even if it is aluminium or carbon fibre. Given the conditions and usual thickness of the materials involved, a measurement of this kind is extremely difficult to achieve with any other equivalent cost technology.

'Engineers that are involved in Formula 1 have identified this very quickly, can see the potential, and have approached us about putting it into custom packages for specific applications.'

One such customer in F1 - a long-established outfit - felt comfortable in taking on Meech's designs to assist them in several new applications. 'We are using it to measure suspension parameters and components within the braking and hydraulic system on the car,' says Meech.

"It can detect a target across gaps of up to 40mm, as well as through most non-ferrous materials"



F1 customers are looking to Reventec's sensor to access previously hard-to-measure areas

One application involves monitoring the movement of a piston within a complex manifold housing. Given the space, size and environmental constraints, conventional sensors are unsuitable. 'Clearly you have a difficult challenge - a piston that moves a small distance very quickly and no physical room for a traditional sensor installation,' adds Meech.

With the Reventec system, the electronics can live outside the housing, while the 'target' - a magnet - can be embedded into the confined area. 'We embed the magnet into the piston, and place the sensor on top or to the side of the housing to monitor the position of the magnet,' Meech explains. 'This product is easily accommodated, measuring only 30x20x8mm deep - it's a compact, miniature matchbox package. It provides a configurable 0-5V

output, but we can also offer it with a CAN output as well.'

Reventec developed custom housings and electronics for the different applications in just three weeks, between showing the first standard sensor at the PRI show in Indianapolis at the tail-end of 2013, and delivering the first finished sensors to the customer in January 2014.

'We have had a lot of interest in this technology, as it offers several clear advantages compared to other position measurement methods,' says Meech. 'In some cases it enables engineers to make measurements that otherwise may have been extremely difficult or impossible to obtain.

'We have worked closely with one F1 customer - with engineers in their electronics, suspension and advanced development departments - to design packages that fit around car components designed for optimum performance. Working together we avoided the need to make changes to the preferred car component designs - we simply made a cowling for the magnet that bonds into the existing piston and installed everything else external to the assembly.

'Another key advantage with this technology is its ability to be rapidly customised for specific applications so I am sure there will be numerous further

developments and subsequent applications for it in F1 and motorsport in general.

'Where our torque sensor is concerned, we have made further advancements and as a result supplied the first units to DC Electronics for their new low-cost electric steering system. We have developed a complete sensor system, hardware, software, the mechanical assembly and the tools required to enable the end user to simply and accurately configure each device to meet their requirements given their application. We have also been working on other applications for customised torque sensors in other areas of motorsport as well as general industry.

'It is a very exciting time for us,' Meech concludes, 'with several new products in development which we hope to bring to market during 2014.' 

"I am sure there will be further applications for the technology in F1, and motorsport in general"

VAC

MOTORSPORTS



Your #1 Source for BMW Stroker & De-Stroke kits
For BMW S65, S54, S50, S14



Billet Dry Sump Pans
Available for BMW S54, & S65



www.vacmotorsports.com - 215.462.4666



Call us first...



Unit 31 Silverstone Circuit Towcester Northants NN12 8TN
T: 01327 857822 F: 01327 858096 www.tridentracing.co.uk

Its all in the prep

Dedicated preparation companies are a massively useful resource ahead of racing, and offer sage advice to help save you headaches further down the line

Regardless of the level at which you compete, preparation - be it prior to a season or a single race weekend - is vital to any form of consistent success in racing. The old British military acronym of the seven Ps - proper planning and preparation prevents piss-poor performance, should be always be kept in mind. Whether you are a weekend racer in a classic saloon or a full-blown GT3 team, preparation is key. So what sort of aspects does one need to consider?

For the purposes of this feature we will concentrate on the work undertaken by professional preparation companies, as they

BY LAWRENCE BUTCHER

invariably see the broad spectrum of racers, from those on shoestring budgets to money-no-object operations. They are a good option for racers who do not want to get massively involved in the technical side of running their cars. But even for those that are happy in the workshop, the specialist skills provided by a dedicated firm's services can still prove beneficial.

Chris Tolman of Tolman Motorsport, who look after clients' cars ranging from historic racers, GTs and even rally machinery explained the benefits of using a outfit such as his. 'What we aim to do is have as much control

of the preparation programme in-house as possible,' he says. 'We have an engine-building department, a full fabrication suite and several workshops. The only thing we don't do currently is machine in house. So we can offer a customer all of those services to a very high standard.'

'I think the thing that makes us unique is that we have the skills and ability to do high level preparation - as we are all ex-WTCC, WRC and GT people - and those skills enable us to build things correctly and in the right manner. That is something that you would not normally find outside of a manufacturer-type team.'

Beyond pre-season preparation, the potential benefits of in-season support also need to be considered. Having some backup during a race weekend is always useful and as such, a tie-up with a preparation company that provides trackside support can be of great assistance. However, as with everything it is very much budget dependent.

'We have some customers who simply turn up at the circuit and drive their cars, and we look after the running and storage,' says Tolman. 'We also provide them with driver training days and testing days, so all of the services are available to them. But then



LAWRENCE BUTCHER

The use of a professional preparation company can greatly reduce early season teething problems

-35mm Worlds apart

Our technology centre is the most advanced in Europe.

That is how we can achieve a negative radius of up to -35mm. Extreme engineering and precision that other performance cam manufacturers in Europe cannot match. All our camshafts and ancillaries have been developed by the best to be the best.

N:1

Kent Cams – the best in Europe:

- No.1 for product development expertise
- The greatest performance increase of any single modification
- The widest range of camshaft ancillaries produced on site

The most advanced technology:

- Negative radius to -35mm
- CBN wheels with constant surface speed
- Multi-angle lobes with CNC dressing
- Marposs 3D C and Z axis position probe
- Microphonic wheel dressing
- Lotus Concept Valve Train software



**HIGH PERFORMANCE
ENGINEERING**

www.kentcams.com

Cams + Pulleys, Belts & Chains : Valves & Valve Springs : Performance Cam Kits & Valve Spring Kits : Followers & Tappets

obp The Original
PRO-RACE V2
Universal Fit Pedal Solutions

The Pro-Race range is a universal pedal solution suitable for most race applications. In 2013 some major upgrades to the Pro-Race series were made and the V2 range was launched. In addition to the added box strength they all now feature:

- Aluminium Billet Pedals
- Pivots on Oil Impregnated Bearings
- Full Bias/Balance Control
 - Adjustable Pedals
 - Available in DBW
 - Amazing Quality
 - Made in England
- Starts from **£209+VAT**

obp
MOTORSPORT
"Innovators not Imitators"

Tel:

01487 812301

www.obpltd.com

Email:

sales@obpltd.com

we also have other approaches. For example, we have a customer in Ginettas - we prepare and setup the car for them in the workshop, and then he simply collects it and runs it. He always has the option that - if he has a problem - he can either go home or, if the budget is available, come and see us and pay for some extra support.'

As has already been touched upon, the cold hard facts of available cash flow will largely dictate the level to which you are able to prepare for a season and the manner in which that season is conducted. Before it is time to even begin thinking about car preparation, first you need to sit down and work out the season's budget as far as is reasonable.

Tom Robinson of Datum Motorsport, a company responsible for running cars in series such as the UK Lotus Cup, explains that 'customers need to be upfront and everyone involved needs to know what sort of budget you are working to.

'You need to look at what budget you have for a season, what you want out of a season and factors such as how much testing you want to undertake. It is easy enough to work out how many consumables you are likely to use - how many tyres, brake pads etc. To this you add the entry and transport fees and however many test days you may want, and from this you can get a reasonable idea of season costs. It prevents you making mistakes like having three days testing at the start of the season and then running out of money at the end as a consequence.'

Sometimes this process can bring home some hard truths, and this is where the advice of an experienced outfit can come in useful. Tolman highlights one case in point. 'I talked one of our clients out of racing a Ginetta G40 and into a G20, because they only just had sufficient money to complete the season in the bigger car. As it stands, they are quick enough that more money will probably come during the year. But if the car had been totalled in the first race, they would have run out of money halfway through the season. Although running the two cars was the same price in



Never underestimate the costs that racing incidents can cause

LAWRENCE BUTCHER

terms of the personnel needed to run them, the parts are cheaper so they aren't going to incur big problems. With the G20, you could rebuild the whole car for around £8000, but you could rack up that amount of damage in one weekend with the G40, by the time you have had a couple of bonnets, radiators and windscreens.

'Ultimately, by moving down a level, this particular client had more money to go testing and therefore improve performance, rather than constantly worrying about money.'

CAR DEALINGS

With a clear financial plan in place for the coming season, attention can then be turned to actually preparing the car. Even at the most basic level, Robinson explains that Datum will complete what amounts to a total rebuild between seasons. 'We will fully strip a car, that is - engine and gearbox out, suspension off, though often we will leave the wiring in place,' he says. 'It depends on the budget

that we have to work with. Once everything is clean we will give the parts a thorough visual inspection, looking for things like cracked welds on the shell and other general wear and tear.'

Once they are happy with the general condition of the base chassis, Datum will then check vital measurements such as the location of suspension mounting points, referencing them back to either previous setup sheets or using them to create new references if none have been previously made.

Following this, a more in-depth examination of the suspension components will be undertaken. 'We always have the suspension components shot blasted and then crack tested,' says Robinson. While this is a not inconsiderable expense, he believes it is well worth the effort if it reveals potential faults that could lead to a failure further down the line. He also points out that although a neatly painted wishbone could look fine under a visual inspection, there could be problems lurking

under the surface that only a full strip and check will reveal.

When it comes to the powertrain, Datum undertake a full strip-down on both engine and transmission to ensure that everything is in tip-top condition, regardless of whether any issues were apparent at the end of the previous season.

'With most cars, we will do a complete engine teardown at the end of a season and then another mid-season, replacing all of the bearings and gaskets,' says Robinson. He also points out that components such as differentials should not be overlooked. Issues such as wear on the plates of a differential are easily overlooked, but can change the way the unit behaves, leading to handling conundrums once out on track. 'If you don't check these things during a rebuild, you can find yourself chasing your tail looking for chassis setup issues when in fact something like the pre-load on the differential plates may have changed without you realising.'

With all maintenance issues attended to, the same level of thoroughness needs to be given to the rebuilding process. Every fastener should be replaced with new, with the same going for suspension bushes and bearings. Once again,



"Customers need to be upfront, and everyone needs to know what sort of budget you're working to"

ACCRA LITE
performance forged
pistons

A DIVISION OF



ENGINEERED TO PERFORM
world leaders in high performance pistons



MANUFACTURERS OF WORLD CHAMPIONSHIP WINNING PISTONS
FOR MOTOGP, WORLD SUPERBIKE & SPEEDWAY. WE POWER
WINNERS IN THE AMA, LE MANS, BTCC AND MANY MORE...



Omega Pistons

Oak Barn Road, Halesowen
West Midlands B62 9DW

Tel: 0121 559 6778

Fax: 0121 559 6779

info@omegapistons.com

www.omegapistons.com

Datum
Motorsport

Full Restoration | Race/Track Support | Race Preparation
Engine and Gearbox Development | Driver tuition



Here at Datum Motorsport we offer
comprehensive support packages for GT and
Sportscars, available for the 2014 season.

Hertfordshire SG4 7DP

| Tel: 01462 790778 | Email: info@DatumMotorsport.com |

www.DatumMotorsport.com



Super1600: 1.6L @ 240 bhp
TouringCar: 2.0L @ 296 bhp

ZOMER
MOTOR
sport

www.zomermotorsport.com

info@zomermotorsport.com

tel. 0031 (0)548 - 361385

ZOMER RACING ENGINES

a potential winner, from start to podium



A properly prepared car will help you get to the sharp end of the grid from the off

LAWRENCE BUTCHER

such attention to detail brings dividends in the reliability stakes, but its impact on costs should not be underestimated.

Once a car is back together and prepared as well as possible in the workshop - with factors such as a baseline chassis setup applied - it is time for testing. To some, pre-season testing can seem like a considerable expense, but thinking that a car can be shaken down during the first practice session of a season is wishful and somewhat naive thinking.

The one area that really cannot be skipped on is ensuring that any car has at least a shakedown test prior to a race weekend. If budgets allow, further testing can be beneficial, but only if it is undertaken with clear goals in mind. 'If we are testing for performance, we will have a professional driver in the car and a test plan mapped out to look at particular areas,' says Tolman. 'When we are working on other areas, such as driver performance, a professional driver will go out and set a delta time, which is usually within a couple of tenths of a representative pole time. The driver will then go out and improve over the day.'

Obviously any testing programme comes at a cost, and that old chestnut of available budget comes back into play. You have to be honest in terms of what benefits going out performance testing will bring in relation to the cost entailed. So, for example, with a new and inexperienced driver, time would probably be better spent improving the driver's skills than the car setup, as more time is likely to be gained in this fashion.

Even the scheduling of when to test can affect overall budgets. A test session on the day before a race can on the one hand be very cost effective, as only one set of transport costs need to be found compared to testing a week or two prior to an event. However, the flipside is that if any problems arise or the car is involved in an incident, there is very little time to put things right, potentially compromising a whole race weekend.

So you have your car fully prepared, tested and have an in-season support package in place, what's left to do? 'Read the regulations,' he says. 'You don't want to find out at the start of the season that you have missed a regulation change that allows you to get more performance.'

'But more importantly, you really don't want to turn up at the first round only to discover that your car is not eligible to run!' **R**

PREP SCHOOL

The University of Bolton's Centre for Advanced Performance Engineering (CAPE) puts students on the road to a career in the fast lane.

Offering degrees in motorsport technology and automotive performance engineering, CAPE is a unique partnership between RLR Msport and the University of Bolton, combining classroom learning with cutting-edge practical experience.

Head of CAPE and RLR Msport team principal Nick Reynolds: 'This is as close to the real thing as students can get.'

RLR Msport is an independent Le Mans LMP2 racing team that competes and works at events around the world. Combining their expertise with the University's two-decade history of delivering automotive engineering courses gives students a unique industry-focused learning experience.

As well as comprehensive classroom and academic provision, the partnership engages students with practical, hands-on trackside training. Students on the courses recently supported RLR Msport at Donington

Raceway, taking part in pitlane and trackside activities.

Alongside RLR Msport's racing and trackside capabilities, the team offers race prep, car restoration, development and testing. The students also work alongside RLR Msport staff.

The on-campus facilities boast wind tunnel and rolling road capabilities as well as CNC, 3D Scanning and the latest industry software and analysis tools.

Academic group leader, Andy Smith says: 'CAPE will put the University and RLR at the forefront of automotive engineering education.'



SAFETY FUEL TANKS

Racing without compromise



OUR PERFORMANCE

- Cost effective solutions
- Shape and size tailored according to customer needs
- Standard fuel cells
- Lightest material on the market at this moment in time
- High quality products
- Supplying racing fuel tanks to the greatest winning teams for 20 years



Complying with all FIA Standards



www.merin.it – info@merin.it
Tel: 0039 - 06 - 9074553



CUSTOM
MANUFACTURED
to your
specifications

FASTEST
TURNAROUND
times in the
industry

Maximize your race engine's potential with our
NEW Titanium Hollow Stem Valves

Ferrea's Titanium Hollow Stem Valves just got lighter and stronger with a complete new design. We have developed a proprietary manufacturing process that gun drills and micro polishes the bore of the valve stem. This proprietary process insures greater structural integrity than any other Titanium hollow valve on the market today. We have achieved a valve reduction in weight by approximately 10 percent compared to solid Titanium valve.



FERREA RACING COMPONENTS
Tech Line: 954-733-2505 • Toll Free: 888-733-2505
www.ferrea.com

FOLLOW US ON:

A tyre testing rig worthy of the hype

In-depth analysis of the SoVa Motion facility at Virginia International Raceway

At the end of every year I embark on a six-week marketing trip. Usually this means that I visit customers, potential customers, as well as running seminars. However, it is not that often that I actually get to report on what I have done. Mostly this is due to customer confidentiality. That being said, last December I had the pleasure of touring the SoVa Motion facilities in Alton, Virginia located at the Virginia International Raceway and all I can say is that any racer worth their salt would be crazy if the didn't consider using it.

In the interests of transparency, I should add that I was so impressed with the SoVa Motion facilities that we are going to be doing some work together.

BY DANNY NOWLAN

To put this into some kind of perspective, I will also add that as ChassisSim has progressed, you need a lot more than great facilities to impress me, because I have seen so many people in this business waste so much money on things that don't count.

The thing that SoVa Motion brings to the party is that it is a complete all-round test facility that has everything you need for proper vehicle dynamics testing. The centrepiece is a flat track tyre test facility that quite frankly is the USS Missouri of tyre test machines - it's in a class of its own. However, there is also an eight post shaker rig, damper dyno facilities and drive time simulators. For any vehicle

dynamics engineer worth their salt, it has a lot of the facilities you need under one roof.

For me the real gem of this facility is the MTS flat track tyre test machine. You can see this illustrated in **Figure 1** (overleaf).

To be quite honest this image doesn't do it justice. It is huge. It's over 6m tall and has a separate room for the controller and another for the electronic control equipment. However, what's even more impressive are the statistics on this machine which are truly staggering. Here are the highlights:

- High speed capability to $\pm 320\text{kph}$ ($\pm 200\text{mph}$)
- Highest wheel torque capability available
- $\pm 10,000\text{Nm}$ (7375lb ft) operable over full speed range

- Uses high response brushless electric motors
- Force limits
- Fx load $\pm 25,000\text{N}$ ($\pm 5620\text{lb}$)
- Fy load $\pm 30,000\text{N}$ ($\pm 6750\text{lb}$)
- Fz load $30,000\text{N}$ (6750lb)
- High tyre positioning rates for transient event simulation
- Slip angle ± 30 deg
- Slip angle rate 90 deg/s
- Inclination angle ± 10 deg
- Inclination angle rate 38 deg/s
- Loaded radii $250\text{-}550\text{mm}$
- Improved control to make system hardware-in-the-loop
- Drive file replay (5Hz) capable
- Wet testing capability

It might be a good idea to explore what these numbers actually mean. Firstly, a max lateral load of 30000N . What this means in practice is this



can test an LMP1 tyre at a peak lateral load of 5g. What's more, with a max vertical load of 30000N this means you can test to a peak CLA of 10.3 at full speed. This is more than enough to cover F1, sports prototypes and would also comfortably cover V8 Supercar and NASCAR. Also, with the slip angle range and rate, you can

comprehensively cover the full range of performance.

Also, given that this is powered by a brushless electric motor, the response is instantaneous. Consequently there will be no time lag, which is crucial for testing, and can't be matched by hydraulic test machines. Also, for those of you who think

I'm talking out of turn, here's a pretty sobering thought - I've been flying radio-controlled electric powered planes for 20 years. F5B/F5D hotliner, pylon racer aircraft powered by lithium polymer batteries and brushless electric motors will out climb an F-15 Eagle to 1000 feet. This is the virtue of instant torque.

Those of you who are regular readers of my articles know that I am not the biggest fan of tyre test rig results. In my experience, it will give you a rough idea of peak slip angle and ratio, and an OK start point for the traction circle radius vs load characteristic. The results then run out of steam very quickly. The beauty about the SoVa Motion MTS tyre test machine is that it goes a long way to bridging the gap to what you'll see on a tyre test rig and what you'll see on the track. I'm not claiming that this is a fire and forget solution, but this machine will go a long way to fill in some big blanks about how tyres work.

The other major facility at SoVa Motion is the eight post rig test facility. Like most rigs, it can simulate road inputs, and aero loads. Also, as expected, you can do track replays or swept sine wave inputs. However, the advantage of the four-input actuators is that it opens up the ability to do warp tests and all other manner of chassis stiffness investigations. This is all pretty standard stuff, which you would expect from any shaker rig facility.

That said, the difference here is that the rig is right next to the damper service shop. Consequently you can go in, do a rig test and get dampers made up on the spot. Also, one of the key personnel is Vince Valeriano, who is a Penske damper/NASCAR veteran, and has been racing in a multitude of formulas for decades. I have a high opinion of most testing rig facilities because they are run by very clever people, but this particular combination is something that makes SoVa Motion very unique.

The outputs of the shaker rig are extensive. To illustrate this, consider **Figure 4** on page 70, which shows an acceleration plot for a racecar.

This is all pretty standard stuff. However, the thing to pay attention to is the left-hand side. Look at the options you have to analyse. We are



Figure 1: the SoVa Motion MTS tyre test machine



Figure 2: slip ratio test

What this translates into is some pretty impressive performance. To illustrate this, consider **Figure 2** (below left) that shows a slip ratio test.

As we can see, we have a tyre under load being burned out. This is a pretty dramatic illustration of what this machine can do. However, what's more impressive is the dynamic slip ratio sweep of a tyre at different speeds, and the results are shown in **Figure 3** overleaf.

The thing to pay attention to in **Figure 3** is the transient results at the 100kph range. Note at peak slip angle the variation in the test results. This is not signal noise - this is the transient variation in tyre force and has certainly given me some food for thought. This starts to give you a really good appreciation for what this tyre test machine is truly capable of.

At SoVa Motion, you can go in, perform a rig test, and get dampers made up on the spot





FUEL CELLS

FIA-Approved Fuel Cells
for Race & Rally



REFUELLING EQUIPMENT

Stockists of Red Head & Stäubli Refuelling Equipment



FUEL SYSTEM SPARES

Your One-Stop Fuel System Shop



ATLL LTD.COM

sales@atlltd.com

+44 (0) 1908 351700

LifeCheck

Component Lifing Software For Professional Motorsport



LifeCheck

Manage the entire
component lifecycle in one
clear intuitive system

Drives improved reliability, better
performance and lower costs

For further information visit
trenchant-tech.com/lifing
To book your **FREE** demo of LifeCheck call:
+44 (0) 1724 897318
or email sales@trenchant-tech.com

talking suspension components, the front and rear axles and many other options. Consequently, they have both the hardware and analysis tools to get the job done. Also, this isn't just limited to the upper end of the sport. See **Figure 5** below for an example of

some analysis that was done for a race performance shop.

Again there is nothing particularly earth-shattering in what we are looking at here. However, the key thing is that it's pretty obvious what is working and the results have

been presented in a clear and concise manner. If you are a circle track racer, dirt late model racer or even in the nationwide series, this rig is worth a serious look.

In addition to all this, SoVa Motion use a variety of in house and third party computer

modelling tools for vehicle dynamics engineering work. As per the eight post rig facility this is all pretty standard stuff, but the thing I particularly like about what they do is that they work under the stewardship of Dr Kevin Kefauver. Kevin has worked in both the OEM and motorsport industries (Dale Earnhardt Racing in NASCAR). However, more importantly than this, he realises that simulation software, regardless of its flavour, is a tool and not a magic wand and that trickles down to his team. This is a point that I have been making for years. Consequently you are going to be getting results that are usable and make sense.

Each of these points on their own are pretty good, but the key thing that makes SoVa Motion unique is that you have all of these facilities under one roof. This is something that is really powerful, because from a vehicle dynamics perspective you have everything you need except for a wind tunnel at your fingertips.

For example, if the simulations are working on a particular problem, they have mountains of real-time tyre data that they can draw on. Alternatively, you can log tyre loads from the eight post track replay and then load this into the tyre test machine.

This kind of capability is something that is extremely powerful, and I think we have only just started to scratch the surface of what this is all truly capable of. Also here is another significant thing to bear in mind: the team here are all vehicle dynamics guys who do tyre testing. Very, very significant.

In wrapping up, if you are serious about your racing, regardless of your level you would be crazy not to give the guys from SoVa Motion a call. So many facilities under the one roof encompasses tyre testing with a truly state-of-the art machine and a host of other facilities that all feed into each other. So regardless of whether you're a club racing team or a NASCAR Sprint car team, these guys are well, well worth a look.

However don't just take my word for it, get in touch with them and see what they can do for you.

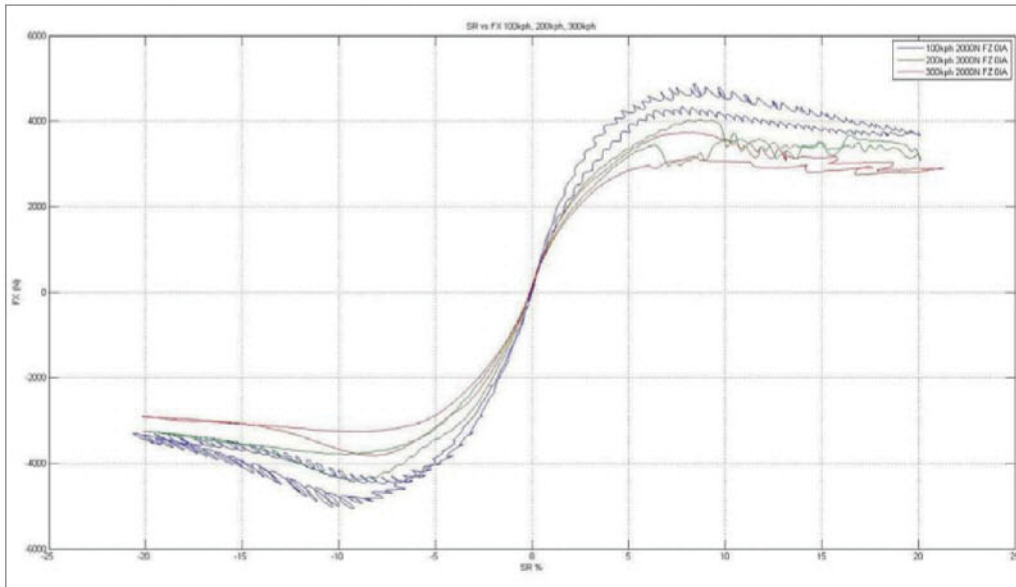

Figure 3: slip ratio and speed sweep results

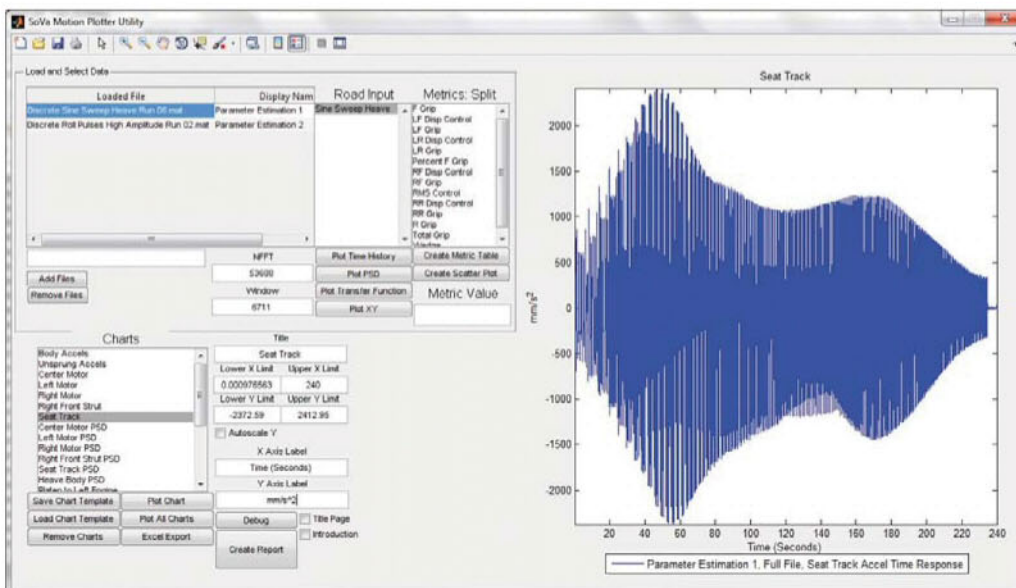
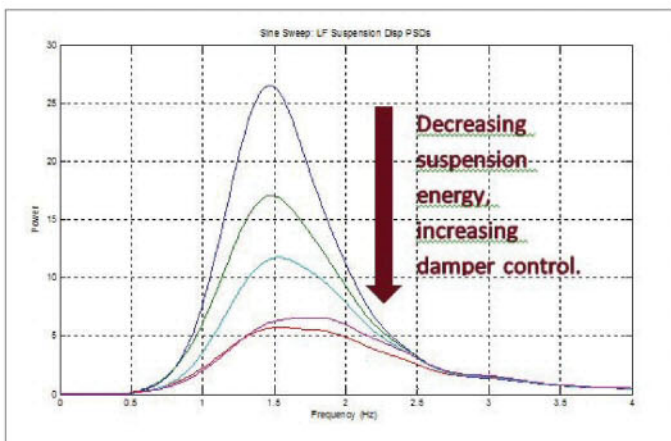

Figure 4: (above) acceleration plot for a racecar

Figure 5: (left) PSD analysis of the left front suspension of different damping configurations



Your tyres are under control



Any type - Any time - Any where

Tyre manufacturer, car maker or motorsport team are always looking for the most cost effective way of tyre characterization and for the best repeatability



Our **Skid Trailer** performs easily tyre characterization for **Force & Moment Models** (Magic Formula...). Our **RMS** manages track characterization and our **TSD** analyses tread dispersion.



www.dufournier-technologies.com



From its Oxfordshire base, FW Motorsport offers a raft of professional services:

- Professional racing team specialising in GT and sportscars
- Experts in racecar preparation and development
- Chassis set-up
- Composites
- Driver tuition and testing programmes
- Complete race weekend support at BTCC rounds
- High performance road car modifications also undertaken by our highly experienced team of engineers

Contact info@fwmotorsport.com

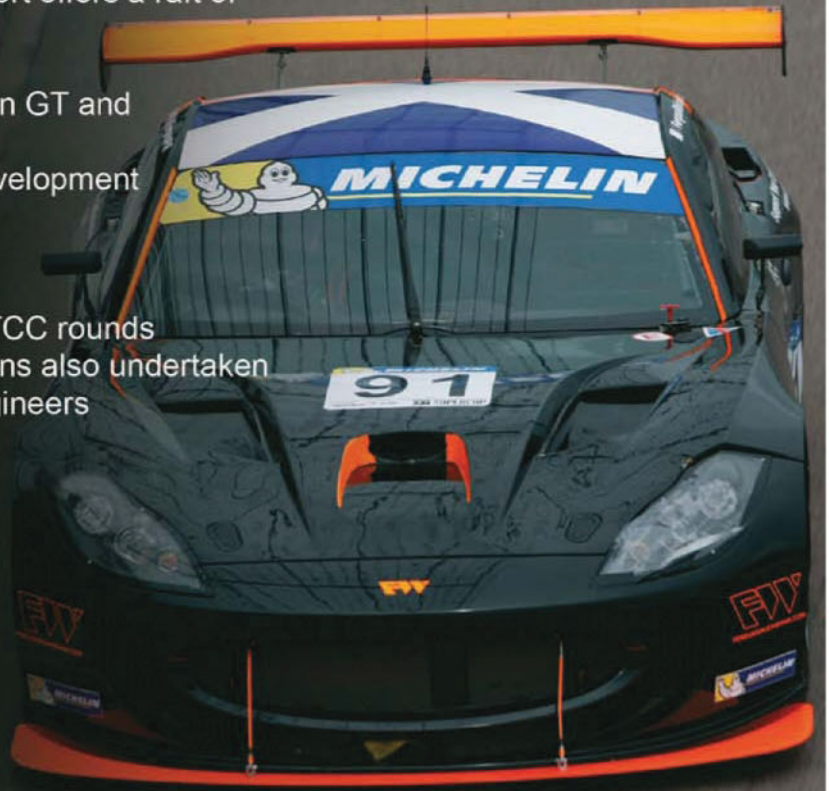

www.fwmotorsport.com

OBR

Control Systems

WHY FOLLOW WHEN YOU CAN..... **LEAD**

SRT
MOTORSPORTS



CONTROLLING THE SNAKE

Ole Buhl Racing are delighted to have been chosen to provide the electronic controls behind the awesome Viper GT3-R

Our award winning PCM2 and EFI Technology's Euro 8 have been placed at the heart of this beast, providing truly spectacular control of this technologically advanced racing machine.

Viper GT3-R

RILEY TECHNOLOGIES

Specialising in engine / power management systems and a complete range of data logging, displays, sensors, actuators and wiring

Ole Buhl Racing (UK) Ltd is a world leader in the supply of motorsport electronics. Our range of innovative products are used in the world's most demanding environments ensuring performance and reliability.

WWW.OBR.UK.COM

WorldMag.net

Trying to keep pace

Balance of Performance has become a hated phrase in racing, and IMSA has taken the process to a whole new level with Daytona Prototypes and P2

BY ANDREW COTTON

The Daytona 24 hours ushered in a new era of endurance racing in North America, and the amalgamation of Daytona Prototype and P2 classes in the top category was always going to be the biggest challenge faced by the rule-makers at IMSA.

The American organisation introduced a new package that increased downforce by 50 per cent for the Daytona Prototypes, but the first test was stopped following two punctures on the Daytona banking that led to huge accidents.

Working with tyre manufacturer Continental, new tyres were brought out for a hastily arranged pre-Christmas test, and the official pre-race test - the Roar Before The 24 - which passed off in January without a recurrence of the problem.

'It was one of those things where we didn't know what the root cause was,' said IMSA's VP of competition, Scot Elkins. 'We worked together with Continental - they made changes to the tyres, and us the cars, and we came up with a solution. I am not sure we still know what the root cause was, but in a situation like that we worked together, and pulled the partners together to make things better. I am sure that we have eliminated the danger.'

The tyres were a bone of contention among the P2 drivers,

who raced on spec tyres on the P2s for the first time. 'How can you have the same tyre for a 1200kg car, and a 900kg car?' asked driver Lucas Luhr, who drove the Muscle Milk P2 ORECA Nissan. 'It was OK during the night when we scuffed a set of tyres, and the second and third stints on those tyres were OK, but they are so hard that you lose feeling from them.'

For the race itself, which took place on 25/26 January, the balancing continued right up until 17 January. The P2s received larger air restrictors and had increased fuel flow restrictors in the pits, but had reduced fuel

tank capacity to make sure they completed around 25 laps on a single tank. Teams argued that, with the speed deficit to the DPs, they needed the opportunity to go longer on fuel to remain competitive over the 24 hours.

The Daytona Prototypes, meanwhile, had their air restrictors decreased to try to reduce their top speed on the banking and acceleration. They also carried four litres more in the fuel tank - 76 litres compared to 72 in the P2s.

Adjustments were also made to the aero kits on the Daytona Prototypes. While the P2s ran the low-downforce homologated kit for Le Mans, the DPs had extensive revisions, with such things as the size of the wing and the Gurney flap mandated. But on the banking, the DPs were much faster.

Teams argued that they needed to go longer on fuel to remain competitive over the 24 hours

The Chevrolet Corvette prototype of João Barbosa, Sébastien Bourdais, Christian Fittipaldi and Burt Frisselle took the win at the Rolex 24





The Daytona Prototypes were much faster than the P2s on the banking

LAT



Lucas Luhr, who drove a P2 ORECA, said that the tyres were so hard that drivers lose the feel from them

LAT

'At Sebring it will be even worse,' said Luhr. 'It is not just the top speed, but they are getting there much faster - they just pull away from us.'

With 67 cars entered, traffic was a problem. The P2s were supposed to be able to overtake better on the infield, but the banking was key to dealing with traffic with the minimum of fuss, and on the predicted run to the flag, the fastest cars would have a clear advantage.

In qualifying, the DPs were much faster, but Elkins was not concerned. 'I don't think there is going to be anything changed before the race,' said Elkins after qualifying. 'Maybe it looks worse than it is. The reduction that we did on the DP cars got us closer to the P2s. We were about 1.6s-1.7s at the Roar, so we adjusted it and now it is about a second.'

'We all know that we are never going to get it perfect, but the raceability aspects of it and

the differences between the DP and P2 are what will come into play. The P2 is lighter, has more downforce, will be better on tyres, while the DP car is a little bit faster on lap times, has faster top speeds, so over 24 hours it will balance itself out, and that's the plan.

'We have got it to the best we can get it - there is nothing drastic that we can do to make it better, so we are going to let them race. The reduction in DP has helped their mileage, and reducing the

capacity on the P2 cars got us close, but we were only a couple of laps apart to begin with. They should be 24-25 laps, which will be about the same.'

The number of yellow flags throughout Saturday and through Sunday afternoon meant that the top cars never got into their stride, and so the raceability was not a factor. Ultimately, however, the unreliability of the P2 cars left the way clear for the DPs to dominate. 'We are doing something that has never been done before and it is not that easy,' said Elkins. 'We get everything as close as we can get to the satisfaction of everyone involved. There is a point where you can do no more without completely redesigning the car.'

IMSA expects to have to make changes to the performance of its top cars throughout the season and on a race-by-race basis. The P2 teams in particular are hoping for a big change ahead of the second round, at Sebring in March. 

"We get as close as we can to everyone's satisfaction, but there's a point where you can do no more without completely redesigning the car"



180 MPH WITHOUT MOVING AN INCH

Take cutting-edge wind tunnel technology. Add a 180 mph rolling road. And build in the best in precision data acquisition capabilities. When we created the world's first and finest commercially available full-scale testing environment of its kind, we did much more than create a new wind tunnel. We created a new standard in aerodynamics.



From the show

Sam Collins reports on the announcements and unveilings in Birmingham

ROTEK'S AUDI S3 BTCC

Robb Holland's Rotek Racing will contest the 2014 British Touring Car Championship in an all-new NGTC-spec Audi S3.

The S3 is the fourth addition to Rotek's stable and its family of Audi racing cars. The team will continue to run its 25 Hours of Thunderhill-winning TT RS, an R8 LMS in various international endurance races, and an RS4 in the German VLN Endurance Championship on the famous Nürburgring Nordschleife.

'Being the first American full-time entry in the BTCC is a huge achievement for both myself and Rotek Racing,' said Holland. 'This is the culmination of several years of hard work and, because the BTCC is what got me into racing in the first place, joining as a full-time entrant is a dream come true.'

'The BTCC rounds I've contested to this point were all done with the view of understanding what the series is about and what it will take for us to be successful in it. We still have a huge amount of hard work to do to make the grid at Brands Hatch, and 2014 will definitely be a learning year.'

'Trying to build a new car and develop it with very little testing is a tall ask for anyone and there are still many tracks for me to learn. That being said, I'm really looking forward to running the Audi S3 saloon. I think it will be a good fit - from a marketing perspective it's great to be running the S3 at this time. Audi has just launched the car and, as the first of the new generation S3s to race anywhere in the world, I'm really hoping that it will attract a lot of attention from Audi fans across the globe.'

'I'm also really glad to have the support of Oakley Motorsports Europe with this effort. It sees the BTCC as the perfect high visibility platform to launch their line of motorsports gear here in the UK and across Europe.'

SENSOR SENSIBILITIES

Gill Sensors revealed that its ultrasonic fuel flow meter has been homologated by the FIA for use in F1 and WEC.

Designed with an innovative, lightweight construction, the flow meter achieves the rapid transit response rate vital for the harsh environment application. It is capable of a flow measurement rate of 8000ml/min and fulfils the FIA's accuracy requirements. It uses solid-state ultrasonic flow measurement technology to detect the flow rate, and can monitor both transient and steady fuel flow, flow direction, fuel temperature and cumulative fuel usage.

'Gill Sensors are thrilled to have been chosen to undertake this extraordinary venture, and we are delighted that the FIA is confident in the performance and durability of the ultrasonic fuel flow meter,' says Mike Gill, chairman of the firm. 'We would like to thank the FIA and all the teams for their backing which has been fundamental to the project.'

The ultrasonic fuel flow meter will remain homologated for use within Formula 1 and WEC throughout the expected lifetime of the turbocharged V6 engine and future designs. However, the market is open for another manufacturer should anyone meet the FIA standards. A late change to the mounting requirements for the meter has also seen some F1 teams having to make late changes to their 2014 fuel system design.

Meanwhile, also present at the show was a new name - Calibra Technology - which will help the FIA enforce the new rules by providing random checks of flow meters throughout the season.

Calibra is headed by managing director Andrew Burston, who spent 10 years with Lola Cars. He later worked for Multimatic before joining renewable racing start-up Hyspeed LLC in 2009.

While at Hyspeed, Burston was the first to identify the potential advantages of an ultrasonic sensor in measuring fuel flow, brought the opportunity to the attention of a sensor manufacturer, and took the concept to the FIA. Burston participated in its technical development and testing methodology from late-2010 until early-2013, when the need for an independent calibration service became clear. Having taken the



JRM THEORY

Motorsport firm JRM has revealed its new Group N specification Subaru WRX rally car at the Autosport Show in Birmingham. The firm is best known for its GT3 specification Nissan GT-R, but has also been involved in rallying for many years. The new car also marks the beginning of an official partnership with Subaru Tecnica International (STI). The two organisations have teamed up to help the Japanese marque to re-establish a front-line presence in the Group N category.

'We're extremely proud to have reached an official agreement to produce Group N rally cars in association with STI,' said James Rumsey, JRM executive director. 'The WRX STI is a formidable performance car and we have found that there is a real hunger in markets around the world for a latest-specification Group N Subaru that is strong, reliable and cost-effective.'

JRM claims that the car is unique and different to other WRX STIs of the same generation because it is the first in Europe to be built in a sedan configuration. The engineers behind the project have chosen this specification because they believe that the sedan offers improved aerodynamics, traction and balance over the alternative hatchback WRX STI.



Honda Yuasa gave its Civic Tourer estate a first public outing at ASI.

The new car is due to make its BTCC race debut at Brands Hatch in March

In association with The International Journal of Motorsport Technology
**Racecar
engineering**



NEW BRIT SPORTSCAR MANUFACTURER

An early announcement at the show came in the form of a brand new car company, Zenos Cars. The new venture has been setup by former Caterham Cars CEO Ansar Ali and COO Mark Edwards. Its first model is the E10 sportscar, pitched directly at the Caterham market. It features an extruded aluminium 'backbone' chassis and is powered by a 200bhp engine, weighs 650kg and should cover 0-60mph in under five seconds. 'In designing the car, it was a fine balance - we wanted it to look aggressive without having an outrageous attitude,' said Ali at the launch. 'We'd already communicated the engineering of the car, so people knew what underpins it, but the reaction to the design and the pricepoint from the press, industry and potential customers has been really positive.' There will be both street and racing variants, with prices starting at £24,995.

lead in creating the test rig and procedures needed to calibrate the sensors for the requirements of F1 and endurance racing, Burston left Hyspeed to form Calibra last year.

'It is very satisfying to be involved in implementing the FIA's vision for bringing racing into line with the concerns of the motor industry and society at large,' said Burston. 'The extreme technical demands of F1 and sportscars threw up a lot of challenges along the way, but now the sport is poised to accelerate the development of the next generation of energy-efficient cars and more sustainable fuels.'

SUBARU LMP ENGINE NO SHOW

RTU Group was expected to have revealed the validated performance figures for its Subaru-based Le Mans Prototype engine, which uses a patented Pseudo Adiabatic system, but were not in attendance, citing 'exclusive and strategic contract' reasons.

Their system utilises lower combustion temperatures to significantly increase efficiency.

Improved power is accompanied by extended durability and reduced fuel consumption and emissions. 'Due to heat and friction in the combustion process, many current engines only achieve 25 to 30 per cent efficiency,' said Dick Kvetnansky, CEO for RTU Group prior to the show. 'With lower combustion temperatures, we can waste less energy and achieve significantly improved efficiency, in the vicinity of 70 per cent.'

'The performance results are phenomenal and the technology can also be retrofitted to any existing combustion engine, if the block can accommodate the additional power. Following an extensive development and testing process, the eLMP engines are ready for automotive and motorsport applications. We're already in discussions with a number of small volume vehicle manufacturers and race teams.'

Racecar's enquiries confirmed that RTU is indeed in negotiations with at least two Le Mans projects, one who is very well known and credible but cannot yet be named.

Attendance numbers point to a positive 2014

There was an air of optimism at the Autosport International Show, and in particular around the Autosport Engineering Show, held in association with *Racecar Engineering*. Overall, attendance figures were up by four per cent, an indication of steady and encouraging growth in the market.

Throughout the trade area of the Engineering Show, exhibitors were asking for more time to be able to conduct their business, and jokingly made a request for a third day. It's not that easy to accommodate, said show organisers, and with the MIA's fine Green Conference held on the Wednesday, debating the technologies of the future, it's easy to spot the calendar clash. However, there was a mood about the place that bodes extremely well for the coming season.

Given the scale of rule changes in Formula 1, at Le Mans with the LMP1 category and in the World Touring Car

Championship, it was surprising that there wasn't more innovation on the floors. I had expected the place to be rammed with new technology, but manufacturers were far too busy meeting tough deadlines - the last F1 Grand Prix was in November, the first test in January, while endurance racing teams looked forward to the Dubai 24 hours and the Daytona 24 hour test session, and race, all in January. There is, it seems, no more an off-season in racing, merely a lull.

There was a shortlist for the Graham Jones Award for Innovation, but it was so short that judges decided not to award the plaque this year. I have little doubt that there is plenty out there begging to be revealed, but the pressures of racing, and producing new technology for the track, rather than an award at a show, took priority. I look forward to a full force debate at the show in 2015.

Andrew Cotton

SEEN: AQUILA ADAMO



The unclothed Aquila Adamo chassis was revealed at the show. The car will be clothed in bodywork designed by a competition winner

On show...

Some of the highlights from Europe's largest motorsport trade show

Photography by **John Brooks**



The days of the Belgian police fielding a Porsche 911 have been eclipsed



Many think this is what Formula E should have looked like. We quite like it



John Surtees's MV Agusta from 1960 took centre-stage in the main show



The Formula E car on display, ahead of its race debut in September



A contender for the Graham Jones Award for innovation - a carbon kart



Steering rack specialists Titan had their range on display



The winning Formula Student entry from the University of Zurich - the first electric engine to beat ICE-powered racers - was proudly exhibited



Pirelli's stand was one of the better looking in the show, for some reason



Companies asked for a extra day of the Engineering show as they were so busy



Rob Austin's new sponsor took pride of place on the Dunlop stand



The March 711 on show. For full details, check out REV21N8



Deputy ed Sam Collins's hair makes him easy to find in Morrisons, and at ASI

STAND AWARDS



ANSYS won the Best Overall Stand in the Autosport Engineering Show



Our very own Tony Tobias hands the Best Small stand award to WDS



Machining company Mazak won the best stand in Manufacturing Technology

MIA AWARD-WINNERS 2014



Jon Hourihan, head of sales at Goodridge (sponsor) presents the Service to the Industry Award to Karen Ellis of Ellis Clowes & Company



Claire Vyvyan, director and general manager at Dell (sponsor) presents the New Markets Award to Nick Carpenter of Delta Motorsport



Francisque Savinien of Performance Racing Industry (sponsor) presents the Export Achievement Award to Chris Gregory, GST Racing Seals



Steve Sapsford of Ricardo (sponsor), presents the Technology and Innovation Award to Lord Drayson of Drayson Racing Technologies



Phil Ward, motorsport business manager at Grainger & Worrall (sponsor), presents the Teamwork Award to Mike Jordan, Pirtek Racing



Julia Schumacher (pictured right) of the Northamptonshire Enterprise Partnership (sponsor), presented the Small Business of the Year Award to David Cunliffe, DC Electronics, with Michael Fallon MP (left) and Lord Drayson



Adrian Moore, Xtrac (sponsor), presents the Business of the Year award - with annual sales exceeding £5m - to Graham Macdonald, Caterham Group

Caterham scoops the MIA Business of the Year award

The Caterham Group has landed the accolade of Motorsport Industry Association Business of the Year at the organisation's prestigious annual Business Excellence Awards.

Caterham won the award in the category for larger businesses with a turnover of over £5m. Graham Macdonald, CEO of the

Caterham Group, accepted the award and said: 'Both CTI and the rest of the Caterham Group are honoured to receive this award from a body whose members are some of the finest engineering minds in the world. This really is an accolade from peers, which makes holding this trophy all the more special and satisfying.'

HIGH PERFORMANCE RACING DEMANDS THE BEST TITANIUM

For 25 years, engineers and designers have relied on Titanium Engineers to provide the highest quality titanium alloys combined with world class technical support. Call us to discuss how our titanium alloys can improve your performance.



Birmingham, UK : +44 (0) 1675-464200
contactus-UK@titaniumengineers.com

Houston, USA : +1 (281) 265-2910
contactus@titaniumengineers.com

Stavanger, Norway: +47 51315785
contactus-NO@titaniumengineers.com

T I T A N I U M E N G I N E E R S . C O M

ultimateTM
Hearing Protection Systems

ultimateear.com
01689 876885



When only the best in hearing protection and comms will do

3Force Combined Sensor G-Force, Gyroscopic, Magnetic

- Simultaneous full triple-axis measurement
- Anodised CNC machined 6016 grade Aluminium enclosure
- Lightweight (<55g) but sturdy
- CAN bus interface with a high level of configurability
- Upgradeable allowing for enhanced functionality
- Spare processing capability for custom firmware

Jacobs Design has been involved in the Australian motor racing industry for the past 18 years and is a highly trusted supplier of sensors to V8 Supercars and Formula Ford.



3Force
cost effective
versatile
resilient

Letter from America

Reluctant traveller Sam Collins reports from the relocated PRI show

I am not a huge fan of Indianapolis at any time of year, but December could be the worst possible time to be there. Imagine my enthusiasm then when the organisers of the PRI show decided to move the event from the Sunshine State to some kind of frozen wilderness calling itself the Hoosier State. The reason for the move is that the show had merged with the upstart IMI show (Indy Meets Indy) and the City of Indianapolis undoubtedly puts rather more effort in than the City of Orlando.

One of the biggest problems with Indianapolis is that its a real pain to get to, especially when the inevitable winter storms pass through the north-east. On arrival I was told many a horror story of travel chaos. Best however had to be VAC Motorsports, who struggled from Philadelphia with broken vans, shipping problems and late night rendezvous. Eventually they made it, as did the European contingent, but only just, as with no direct flights to Indianapolis from anywhere outside North America, many were badly delayed by the weather.

'This show had better be worthwhile,' one English exhibitor

grumbled. 'If it's not, there is no way we're coming back.'

Now I know that the exhibitor in question will be back, and despite my misgivings PRI 2013 was the best motorsport trade show I have attended. I got an inkling of how good it was going to be when I found that every single flight from Charlotte, North Carolina to Indianapolis was fully booked, and pretty much every seat was taken by someone who worked in the motorsport industry.

As for the show itself, once I had survived the -12degC temperature walking from the hotel, I discovered that it was absolutely huge. It took two full days to find all of the exhibitors, with many tucked away in side rooms and in corridors. The whole North American industry was represented, as were plenty of exhibitors from around the world - in fact only the Japanese were not represented in great numbers.

On top of that there was an improved and enlarged Race

Industry Week preceding the main attraction, with seven major events among 45 conferences and seminars that ran in conjunction with the show. The Advanced Engineering Technology Conference (AETC), Advanced Vehicle Dynamics and Data Acquisition Seminar, the Race Track Business Conference, the International Council of Motorsport Sciences (ICMS) Annual Congress, the Winning the eRace Digital Marketing Conference, and SEMA's Motorsports Parts Manufacturers Council (MPMC) Education Day were among the highlights.

All this isn't to say that the show was perfect, as it was not. Having become so used to the simple setup of the show in Orlando, the layout of stands in Indianapolis was hard to adapt to. On top of that, signposting around the venue wasn't clear - a few more maps with 'YOU ARE HERE' dotted about the place would help a lot, while some sections were a little unhelpfully situated.

One big difference to other trade shows like PMW and the Orlando-based version of PRI was the lack of established networking spots. Because of the freezing weather, many attendees remained in the hotel bars rather than touring around to the various drinking holes. Perhaps the PRI team should designate a few bars in the City as official post show networking locations?

Bit maybe John Kilroy, the man who runs the show, was listening to what people were saying. 'It's been the busiest PRI Trade Show ever,' he enthused at the end of the third day. 'We are receiving positive comments from exhibitors as we walk through the aisles, describing the amount of business that they've been able to do this week and how pleased they are with the number - and quality of buyers. The big return of the PRI Trade Show to Indianapolis was a pretty spectacular success for our attendees and exhibitors. We also learned some areas where we can tune up the show for 2014.'

One area that could certainly be improved is regarding the travel options. There are no direct flights to Indianapolis International from Europe. Perhaps the show organisers could charter a 747 and fly all of the European contingent over in one go, with stand equipment staff and everything? In fact the possibilities of this are rather amusing - imagine who PRI would hire to do the cabin service! *(Just imagine! I nominate Dep ed Collins and will put Ad manager Mills in charge of selecting his outfit - Ed).*

PRI is once again a great show. I'm still not a fan of Indianapolis, but it looks like every December from now on it is where I will be. I suggest it is where you should be too - just remember to wrap up warm!

The 2014 PRI Trade Show takes place 11-13 Dec at the Indiana Convention Center.

Despite my misgivings, PRI 2013 was easily the best motorsport trade show I have ever attended



Many suppliers arrived at PRI fresh from the 2014 NASCAR Sprint Cup test at Charlotte Motor Speedway, meaning that flights between North Carolina and Indianapolis were fully booked.

Zero Shear Shock Fluid

Driven SHX Shock Fluid utilises next generation synthetic oil technology to provide consistent, fade-free dampening performance. This unique, competition proven formulation utilises a proprietary additive package to reduce seal drag, improve air release during fluid handling and maintain viscosity under high temperatures and high shear forces. SHX outperforms conventional formulations and delivers consistent dampening in demanding applications like off-road trucks, motorcycles, rally cars and tarmac race cars.

VISCOSITY BREAKDOWN
% Viscosity Loss In KRL Shear Test

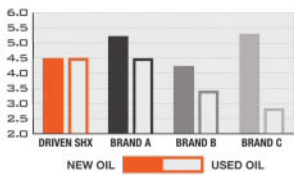

Driven SHX does not lose viscosity even after repeated heat and shearing cycles.

BORN FROM JOE GIBBS RACING
DRIVEN
DRIVEN TO WIN RACING OIL®



Part Number 50040

www.DrivenRacingOil.com + 1-866-611-1820

European and Middle East Distributor:

Anglo American Oil Company - www.aaol.co.uk +44 (0) 1929 551557

PRO-SHIFT™
electronic gearshift

Championship Winning
Semi-Automatic Electronic Gearshifters
for Racecars & Superbikes

Now available
This superfast and highly sophisticated
Gearshifting PS3 Paddleshift System suitable
for **Racecars and Superbikes** with over 170
adjustable parameters

PS3 System
Offering Fully Closed Loop Gearshifting for
both Racecars and Superbikes

Auto-Blip & Downshift Lockout
For clutchless downshifts plus engine over-rev protection

Graduated Ignition Cuts
Individually programmable for all gears

Auto Upshift Facility
Max power upshifting at full throttle..!

For more information:
email: info@proshift.com
telephone: +44 (0)1332 668100

www.proshift.com

Exhausts and fluid pipes made direct from CAD data

BTB EXHAUSTS

From concept to reality, BTB Exhausts, your perfect partner for optimum engine development.

0044(0)1327 261797
www.btbexhausts.com

Top Qualifier

Around the world or around the track, you won't find a higher quality line of bearings and rod ends with Aurora's proven 35 year track record.



Aurora Bearing Company
901 Aucutt Road
Montgomery IL. 60538



Complete library of cad drawings and 3D models available at:
www.aurorabearing.com Ph: 630-859-2030

Peterson

FLUID SYSTEMS



MADE IN THE USA

Peterson Fluid Systems manufactures top level quality oiling and fuel system components for motorsports. We have been the choice for top teams and auto makers for the last 30 years. Contact us today to see how we can help you with your project!

1-800-926-7867 petersonfluidsys.com

Racing Car Air Lift



- Lifts Vehicles Safely and Quickly
- Supplied Tested and Ready to Use
- 600 Kg S.W.L. Per Pair
- Full Range of Servicing Options Available
- Existing Supplier to Many Motorsport Teams



Tel: 024 7637 4114
Fax: 024 7634 7520
Email: sales@camozzi.co.uk
Web: www.camozzi.co.uk

SSIT

SS TUBE TECHNOLOGY
ENGINEERED BY DESIGN



**EXHAUST SYSTEM DESIGN AND MANUFACTURE
HEAT SHIELDS • EXHAUST LAGGING
THERMAL MANAGEMENT SOLUTIONS**

www.sstubetechnology.com

Oxfordshire Tel: +44(0)1865 731 018
Email: info@sstubetechnology.com

UK's Motorsport Valley industry cluster rakes in £9 billion

A review of UK motorsport business has shown that the sector has enjoyed a remarkable recovery since the downturn in 2008, with sales of £9bn being achieved for 2012.

The review, which was commissioned by the Motorsport Industry Association (MIA), showed that the companies that comprise the UK Motorsport Valley business cluster hit the highest sales level ever in 2012, on the back of continuous growth in every year since 2009.

According to the survey, which is supported by The Department for Business, Innovation & Skills (BIS) and UK Trade & Investment (UKTI), this £9bn turnover (in contrast to £4.6bn in 2000, when the last survey was completed) was generated by some 4300 companies, employing 41,000 people.

The survey noted that a high level of investment in R&D - on which many firms spent more than 25 per cent of their annual turnover - was vital to this

success, as was the high calibre of employees at motorsport companies. Exports were also important, with nearly 90 per cent of the companies selling overseas.

Formula 1's presence in the UK, and the supply chain that supports it, also helped boost the figures. Eight out of the 11 F1 teams are located in Britain and this sub-set of the wider UK motorsport sector employs more than 5000 highly skilled individuals, delivering more than £2bn each year in revenues, says the review.

A growing number of motorsport companies also reported success from offering their race-honed capability and expertise to adjacent sectors, particularly with energy efficient, low carbon solutions, and motorsport companies have fared particularly well in the automotive and defence sectors.

Chris Aylett, CEO of the MIA, said: 'British motorsport companies are proven world champions. Highly-publicised

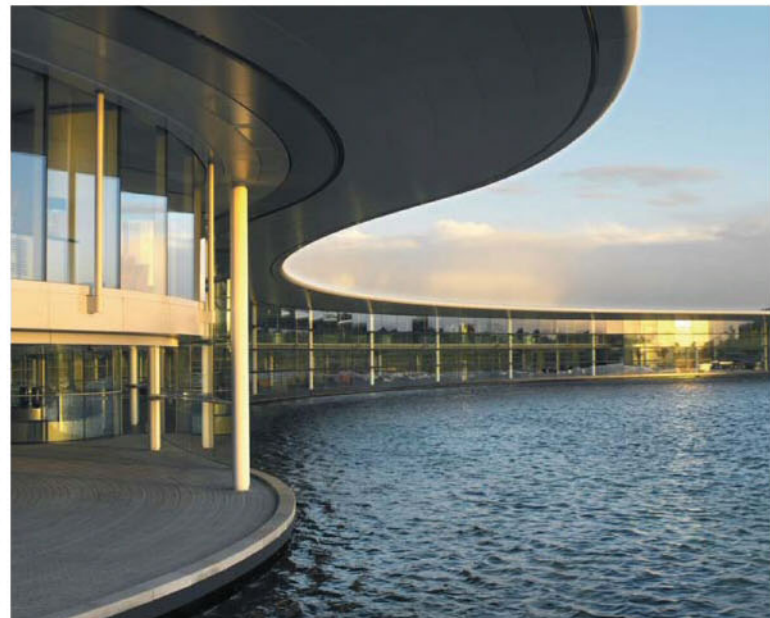

The McLaren Technical Centre in Woking - F1 teams contribute significantly to the UK motorsport industry's impressive turnover

victories on racetracks around the world are a strong promotion for this jewel in the crown of UK advanced engineering. At last, the expertise of these companies is being more widely recognised and

valued by other industries. Every race or rally is won by the team which uses its energy resource most efficiently, and now this capability is bringing new business to this sector.'

Soccer media company scores F1 rights

Leading international soccer media rights company MP & Silva has signed a six-year agreement with Formula One Management (FOM) for exclusive F1 media rights for the Middle East.

The deal will cover the MENA territories (Middle East and North Africa, extending from Morocco in the west to Iran in the east) plus Poland, Romania and Bulgaria, and includes all races, qualifying and practice sessions from this season. The Bulgarian part of the deal, however, does not come into play until 2015.

MP & Silva owns, manages and distributes television and media rights to some of the most prestigious sports events around the world. It boasts an annual turnover in excess of \$500m, and its worldwide soccer partnerships includes UK Premier League rights, worldwide rights to Italian Serie A,



The deal covers the MENA territories, plus Poland, Romania and Bulgaria

French Ligue 1 and US Major League Soccer, while it is also the distributor to selected markets for the 2014 World Cup in Brazil, German Bundesliga and Spanish La Liga.

The F1 acquisition moves the company beyond its core activity of football rights distribution for the first time.

Andrea Radrizzani, founding partner at MP & Silva, said: 'We are extremely honoured with this long-term relationship with Formula 1 as very few companies worldwide have the privilege of being selected as sales representative for the FIA Formula 1 World Championship.

'This partnership is a recognition of our leadership in the sports media rights market, and we look forward to supporting Formula One Management in furthering Formula 1 racing's popularity in general and to guarantee improved audiences of F1 races in MENA.'

Bernie Ecclestone said: 'The purpose of this agreement is to help grow interest in Formula 1 throughout the Middle East and I am confident that MP & Silva can help us achieve that.'

New F1 tyre deal for Pirelli

Pirelli is set to continue as Formula 1's tyre supplier for the next three seasons.

The Italian company, which notably endured a troubled 2013 following a string of high-profile issues with its tyres, said a new contract had been signed following changes to the rules.

Pirelli has long complained that F1's in-season testing ban has prevented it from conducting the necessary research.

The rule changes, however, allow limited in-season tyre testing during the coming season. Changes to F1's sporting regulations also mean that one of this year's pre-season test days will be devoted to wet-weather tyre testing, while teams must give up one of their eight in-season test days exclusively for tyres.

V8 Supercars scoops quarter-billion dollar TV deal

Australia's top motorsport series, V8 Supercars, has landed a six-year broadcast deal said to be worth AUS\$241m (US\$214m).

The deal was signed with Foxtel, FOX Sports and Ten Network, and is said to represent a significant increase on all previous TV deals for the Australian touring car series. The new agreement gives the broadcasters involved all media rights, including digital, from 2015 until the end of 2020, and is said to be worth AUS\$196m in cash and AUS\$45m in advertising.

This new deal represents something of a turnaround for

the series, which was forced into a last-minute TV arrangement just before the start of the 2013 season, when it signed a two-year agreement with Australia's Seven Network which was worth just AUS\$18m per year.

V8 Supercars CEO James Warburton said of the new agreement: 'This is a tremendous and significant deal for our sport. It is a great boost to our amazing race teams and fans and will lead to unprecedented coverage on multiple platforms for our sport, never before seen on such a scale.'



The six-year broadcasting contract is a significant increase on previous deals

Prodrive to move out of iconic Banbury base

Well-known UK motorsport and automotive engineering company Prodrive is to move out of its famous premises, while it is also planning involvement in the all-new Formula E Championship.

Prodrive chairman David Richards has said that the company will be moving to a new site, also in Banbury, and that the move will begin in April and should be completed by the end of 2014. 'We're going to be moving, our iconic site alongside the M40 motorway is going to be no more,' Richards said at the Autosport International show. 'We've sold the site to Marks & Spencer - they will build a big flagship store there, and we will move up the road about half a mile,' he added.

The new HQ will be in the factory previously occupied by automotive parts manufacturer Hella. 'It's not necessarily bigger or better, just more appropriate for our longer term needs,' Richards explained. 'We need to consolidate the business. We need to work in a different way to how we did 30



Prodrive chairman David Richards

years ago when we first started. It's a chance to rethink the structure of the business and look at our longer term plans as well.'

Richards also confirmed that Prodrive is looking closely at Formula E. 'We're interested in it for two reasons: from an involvement point of view - and we will be announcing something about that soon - and from the technology side. Our engineering division does a lot of work for the mainstream manufacturers, and we've got quite a bit of technology that's appropriate to Formula E.'

SEEN: NISSAN ZEOD 1.5-LITRE ICE



The ZEOD RC is set to become the first Le Mans entry to complete a lap of the Circuit de la Sarthe under nothing but electric power. However, a relatively overlooked part of the package is the accompanying internal combustion engine. The DIG-T R (left) is a 1.5-litre, three-cylinder turbo, weighing just 40kg, but the compact unit produces around 400hp. 'We knew the electric component would turn heads,' said global motorsport director Darren Cox. 'but our electric/petrol powerplant is quite a stunning piece of engineering.'

Fuel efficiency continues to drive automotive market

Car manufacturers are likely to continue to press for more motorsport series which emphasise the fuel efficiency of competing cars, the results of a recent global survey suggests.

The KPMG International Global Automotive Executive Survey, based on interviews with leading executives in the industry, shows that the market is crying out for smaller, more efficient engines.

There is also a rising demand for new technologies, with over 69 per cent of respondents saying that fuel cell technology will be crucial to future growth by the end of the next decade.

But the survey shows that while manufacturers are working hard to bring new technologies to market, the process takes time, so downsizing

of the internal combustion engine (ICE) remains the priority, and will continue to attract the most R&D investment. Indeed, 76 per cent of respondents said that ICE downsizing and optimisation is a key issue, compared to just 59 per cent for battery-powered technologies.

'Continuing consumer concern with fuel efficiency and pollution is urging automakers to focus on plug-in hybrid and fuel cell technologies for the near future,' said Mathieu Meyer, global head of automotive at KPMG. 'Since the development of e-vehicle technology takes time, in parallel, automakers are also maintaining a strong grasp on downsizing the internal combustion engine to meet the needs of the current marketplace.'

RINGSPANN®

RCS® Remote Control Systems



Market Leading Manufacturers of Control cables for:

- Gearshift
- Throttle
- Handbrake
- Clutch
- Support
- Anti-roll Bar
- Fire Pull



Contact details
RINGSPANN (U.K.) LTD.
3 Napier Road
Bedford MK41 0QS

GORDON RISELEY
Office: 01234 342511
Mobile: 07831 863008
Email: griseley@ringspann.co.uk
www.ringspann.co.uk

A. 52



Q. How many Woodward pinions are in current production?

...and the other answer is, YES, we manufacture the widest selection of race car power steering in the world, and we probably have a pre-engineered solution for YOUR project.



Just e-mail your requirements to tech@woodwardsteering.com

CARTEK

MOTORSPORT ELECTRONICS



NEW
Power Control Panels

Innovative products:

- Solid State Battery Isolators
- Power Distribution Modules
- Wireless Steering Wheel Controls
- Coolant Sensors
- FIA Rain Lights
- Shift Lights



www.CARTEKMOTORSPORT.com
CARTEK AUTOMOTIVE ELECTRONICS Ltd
44 (0)2380 637600
info@cartekmotorsport.com

JLS MOTORSPORT

- Air Jacks**
- Designed & manufactured by JLS Motorsport, bespoke strokes are available.
 - Manufactured with forged alloys & high tensile steels
 - Lightweight & compact in design
 - Delivering maximum performance & optimum safety
 - All Air Jacks are supplied with 3 location rings for positioning & alignment



Air Jack Lance

Air Jack Probe

Made in the UK
European Sales

JLS Motorsport
email : motorsport@lister.co.uk
tel : +44 (0)121 525 5800
fax : +44 (0)121 525 4833

USA Sales
XRP THE XTREME IN RACECAR PLUMBING
XRP Inc. email : sales@xrp.com
tel : 562 861 4765 fax : 562 861 5503



Onyx reforms for World Touring Car Championship



The Onyx name returns to world championship action this year for the first time since 1990 - only this time featuring a roof

Former Formula 1 team

Onyx has been reformed by its erstwhile boss Mike Earle, with the aim of competing in the World Touring Car Championship for the next five years.

The team, which at the time of writing had not announced which car it would be campaigning, has said that it's been working on the project for over nine months. Earle has previous WTCC experience with his Arena Motorsport team in 2012, which also raced in the BTCC and sports cars, including at Le Mans.

Earle has reformed Onyx Race Engineering in conjunction with Arlington Industries Group, which is a privately held industrial investment company with interests in industrial

coatings, aerospace, and automotive manufacturing.

'This association is exciting,' Earle said. 'It is a unique opportunity to assemble such a strong automotive group with the common intention of success in the finest touring car championship in the world.'

Onyx has an impressive record in racing that dates back to the team's early successes in F3, F2 and Formula 3000 in the 1980s, culminating in Stefano Modena's title in the 1987 F3000 Championship. It then raced in Formula 1 in 1989 and 1990, taking a memorable podium during its first season, when Stefan Johansson came from 12th on the grid to finish third at Estoril.

IndyCar body kits set to be cost-capped at \$75,000

IndyCar has moved to allay fears that the introduction of aero kits in 2015 will result in an escalation in budgets for the teams by placing a cost cap on the kits.

The body kits, which have been a fundamental part of the new IndyCar philosophy since Dallara won the bid to build the new car, the DW12, have been put on ice for its first two seasons due to worries over costs. But now IndyCar has announced that Honda and Chevrolet will produce the first aero kits for next season.

IndyCar said the kits will allow for greater visual differentiation between the cars, as well as providing a base for performance improvements. A car adopting a manufacturer's kit will also take on the name of that company.

The rules allow for the addition of kits from any other

engine manufacturers who might become involved in IndyCar in the future, as well as any independent companies who wish to become approved suppliers.

Derrick Walker, IndyCar's president of competition and operations, said: 'Aero kits will improve the diversity of the fan experience and renew technical engagement, while providing a controlled cost structure.'

This cost structure will involve a price limit of \$75,000, which includes everything except for body fasteners, while an update kit for 2016 will cost no more than \$15,000. Teams will be restricted to just two aero kits a season.

The areas of the bodywork the kits will cover include engine cover, sidepods and certain parts of the front wing for oval race aero setups.



IndyCar teams will be restricted to just two aero kits a season

NBA team owner nets investment in Formula E

The CEO and co-owner

of legendary NBA basketball team the Boston Celtics has announced that he is to make a significant investment in Formula E Holdings, the company behind the all-new FIA Formula E Championship.

Wyc Grousbeck, together with his Causeway Media Partners concern, will make a 'multi-million' investment into the electric racecar championship, which kicks off in September and is set to include two rounds in the USA - Miami and Los Angeles - which both take place in the spring of 2015.

Grousbeck will also serve on the board of directors at Formula E Holdings, which was appointed series promoters of the championship in August 2012 by the FIA.

He co-founded Causeway Media Partners in May 2013 with long-time investing partners Bob Higgins and Mark Wan. Grousbeck, along with his father H Irving Grousbeck, also founded Boston Basketball Partners, the group which purchased the Boston Celtics for \$360m in 2002.

'We aim to help make Formula E a worldwide sensation, with a focus on the development of high-speed electric racing in the United States,' Grousbeck said. 'With our upcoming races in the centres of Los Angeles and Miami, we will help to showcase the power and promise of sustainable vehicle technology, while entertaining millions.'

'Causeway's mission is to find investment opportunities that benefit from our deep network of NBA and NFL team owners, media executives and professional investors. Formula E is a perfect match. At Causeway, we know the power of competition and entertainment, and will bring our knowledge to the development of the market for electric vehicles.'

Alejandro Agag, CEO of Formula E Holdings, said: 'Wyc brings with him extensive knowledge and experience of the US sports market which of course remains a key area for Formula E given we have two US-based teams, two US cities, broadcaster FOX Sports and of course the US's ever-expanding electric vehicle market.'



- Race Car Preparation Specialist
- Competition Car Storage
- Suspension Design & Manufacture

01268 207000
www.mattroachracing.com

Follow Us On  

Units 5 / 8 Glasshouse, Lubards Lodge Farm,
 Hullbridge Road, Rayleigh, Essex. S56 9QW

London Motorsport Showroom



msar

www.msar.co.uk
 ORDER HOTLINE: 020 8655 7877



ADVANCED SUSPENSION TECHNOLOGY
 ÖHLINS HAVE WON OVER 200 WORLD CHAMPIONSHIPS
MICK GARDNER RACING



OFFICIAL DISTRIBUTION FOR ALL ÖHLINS PRODUCTS

Factory Trained Technicians // Large Stocks of Shocks, Springs and Parts
 Official Sales and Service Centre // Fast Turnaround on Servicing, Revalving, etc.
 Bespoke Shock Absorbers Built to Customer Spec

.....

CONTACT RUSS WALTON @ MICK GARDNER RACING NOW
 E-mail: russwalton@mickgardnerracing.com
 Website: www.mickgardnerracing.com
 Telephone: 01226 240 099



WE CUSTOM MAKE STAINLESS STEEL EXHAUST SYSTEMS



Tel: 01753 532 222
 /SimpsonRaceExhausts
 @SimpsonExhausts
 E: matt@simpsonraceexhausts.com

www.simpsonraceexhausts.com

BUSINESS INTERVIEW - ALEJANDRO AGAG

Mister E

The man behind the FIA's new electric racecar championship tells us why the great and the good are flocking to Formula E

Electric car racing has been the future for so long that it's difficult to get your head around the fact that it will very soon be the present. But come September this year, 20 softly purring racecars will be lining up for the first FIA Formula E race in Beijing, and what's more some of the biggest names in motorsport and business will be cheering them on. These people have been enticed by the green credentials of the series, lured by its business opportunities - and ultimately persuaded by the man who has so successfully sold the FE concept.

That man is Formula E Holdings CEO Alejandro Agag, a former politician, a businessman of some repute, and until recently the boss of the Addax GP2 team. Among those he has brought into the FE fold are Alain Prost, Michael Andretti, DAMS boss Jean-Paul Driot, Aguri Suzuki, Richard Branson - even Leonardo DiCaprio - all on-board as team owners or sponsors. Not to mention the big name technical partners such as Dallara, McLaren, Renault and Michelin.

Not a bad start then? 'It's key for us to have the backing of big motorsport names but also key global environmentalists,' says Agag. 'DiCaprio and Branson have both shown their support alongside racing legends like Prost and worldwide racing names like Andretti and Audi [the latter indirectly through FE participant Abt]. To have names like this commit to Formula E with months still to go until the first race sets a real precedent.'

The attraction of non-motorsport people because of the environmental credentials is perhaps not surprising, and the



same goes for sponsors who wish to be seen in a green light. But what's the pull for those hard-nosed racing people, like Andretti and Driot? Agag insists it's simply down to a good business plan, which is based upon strict cost control but with a 'high revenue model' - that is, the money coming from the sponsors.

Agag previously told *Racecar* that an FE team budget could be around the \$3m mark - or even as low as Formula 3. However, when we tried to verify this in a more recent conversation, he would not commit to a figure, presumably because it's too early in the day

to nail down costs. Regardless, suffice to say that the aim is to keep those costs low. 'Limiting costs is very important to Formula E,' says Agag. 'And we have a number of measures in place to address this. Restricting the number of team personnel is perhaps one of the most significant, together with housing the cars at a central workshop, right down to smaller measures like not changing tyres so teams don't have to invest in expensive pitstop equipment.'

Yet while this sounds fine on an operational level, part of the *raison d'être* of FE is to advance

technology, particularly after year one when it ceases to be a spec formula. So surely budgets will soar when teams develop the technology to find an edge? 'While manufacturers can spend budget on developing cars and technology - and we want them to in order to accelerate EV technology - the teams will still be limited when it comes to the number of race personnel and other cost control measures, and therefore budget, which is important to us.'

While it remains to be seen how the cost control measures will balance the teams' and manufacturers' spend on research and development, there seems no doubt that there does need to be a spend on R&D, for the electric racing car - in this case the Spark-Renault SRT_01E - isn't quite as efficient as it might be, particularly when it comes to battery life. Indeed, in the first year each driver will need to swap cars mid-race, something which surely can only bring attention to the fact that EVs are simply not yet up to the task?

'It definitely does,' concedes Agag. 'And we are perfectly aware of that. But it also adds a lot to the show, so the television will love it, and once we have extended the range on the batteries in year three, four, five, then we will have shown clearly the evolution. So, this is the starting point. It's a long-term project, and in the longer term the evolution from changing cars after 25 minutes, after 35 minutes, to 45 minutes, and then not having to change the cars will really show the evolution.'

Part of the solution will involve wireless recharging. The wireless



"Limiting costs is very important, and we have a number of measures in place to address this"

charging will come thanks to our official technology partner Qualcomm, but the plan for season one is just to fit it to the safety car and use that to develop the technology with a view to fitting it to the racecars in future seasons. It's really impressive technology and shows what can be achieved.

'There are different ways of charging the cars wirelessly. One of the more straightforward methods is using a special pad developed by Qualcomm, whereby the car just parks over it and the charging begins. Other methods use dynamic charging, where sensors are placed in the road and when the car passes over it gives it a charge. Although they have to be fitted, they have multiple usages as in addition to the Formula E cars using them. They can be left in the road for cities to utilise for public transport.'

City centre racing is actually a central plank of FE. Playing on its quieter power source, it's ideal for street racing and it has landed events in London, Beijing, Rio, Los Angeles and other cities as part of its inaugural 10-round championship. But hosting a street race means big money, and Agag admitted that *Racecar* was not wide of the mark when we suggested that it costs €1.3m per km to stage such an event. 'But then we will race for 2.5km only, because our circuits are shorter, then the cost is lower,' he says. And who will meet these costs? 'It's a combination of everyone involved, from Formula E Holdings

to cities and local authorities and of course our partners.'

Those partners will be crucial. They will be attracted, and indeed have already been attracted by the prospect of being associated with a sustainable form of motor racing, and they are sure to benefit from the interest that the championship will generate around the world during its first season, as well as the big TV deals that FE has signed. But just how will interest be maintained when the initial novelty value has worn off? 'One of the most important aspects of Formula E will be to deliver great, close racing, and this is what will hopefully keep fans coming back year after year. But also, by making the racing interactive - with features like our real-time videogame and social media voting - can give an extra 'powerboost' to their favourite driver.'

It's perhaps not something your average F1 enthusiast would go for, but then Formula E is not Formula 1, and Agag is looking more to the youthful games market, rather than existing race fans. 'We're aiming for a younger audience,' he says. 'The key is interactivity, videogames, push to pass, social media. The younger generation don't want to watch any more - they want to play, so we will give them games and interactivity, and they can then get involved.' So Agag's convinced Branson, DiCaprio and Prost. Now he just needs to convince the PlayStation generation.

Mike Breslin

Alejandro Agag indicated that earlier reports suggesting that Formula E races will cost €1.3m per km to stage were not too far from the mark



RACE MOVES

Mercedes has snapped up two key figures from the Red Bull technical staff with the signing of **Giles Wood** and **Mark Ellis**, both of whom are set to join Mercedes in June once their Red Bull contracts have run their course. Wood will be chief engineer for simulation and development while Ellis will become Mercedes' performance director.

Former F1 designer **Sergio Rinland** has joined up with new Auto GP team Puma 3 M-Sport. Rinland, who worked for Brabham, Sauber and Benetton and other teams during a 30-year career in Formula 1, will now take control of the team's car development and operations.

Richard Cregan, the chief executive of Abu Dhabi Grand Prix venue Yas Marina, and also a former Toyota F1 team manager, has been drafted in to help out with the inaugural Russian Grand Prix. Cregan's Rasgaira consultancy company has entered into a three-year deal with the promoter of the Sochi-based event, **Oleg Zabara**. Cregan will remain involved with Yas Marina as an advisor.

Antonio Spagnolo will be **Kimi Räikkönen's** race engineer at Ferrari for this season. Spagnolo started his F1 career at Minardi and joined the Scuderia in 2005, most recently working as part of **Fernando Alonso's** engineering team alongside **Andrea Stella**.

NASCAR has appointed **Jimmy Small** as president of Iowa Speedway, the track the US stockcar governing body acquired at the end of 2013. Small joins the Speedway after six years with NASCAR in various business-building capacities. Most recently he served as senior manager for team marketing services within the NASCAR Industry Services department.

Former motor industry executive **Brent Dewar** is now chief operating officer at NASCAR. Dewar enjoyed a long career at GM, but more recently he has been managing partner at Whitby Advisors, the company through which he has acted as a consultant to NASCAR.

As part of the same NASCAR management reorganisation that brought in Dewar, **Steve Phelps**, NASCAR's senior vice president and chief marketing officer, and **Steve O'Donnell**, senior vice

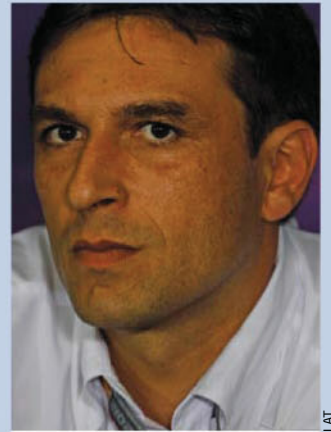

Reigning champion F1 team Red Bull Racing has promoted **Pierre Wache** (above) to head its Vehicle Dynamics department. Wache joined Red Bull from Sauber in June of last year and now takes over the role vacated by **Mark Ellis** (see above left).

president, racing operations, have both been promoted to executive vice president. The company's general counsel, **Gary Crotty**, has been elevated to chief legal officer/general counsel.

NASCAR has also promoted **Dr Michael Lynch** to the position of vice president, green innovation. Lynch joined NASCAR in 2008, shortly after NASCAR chairman and CEO **Brian France** declared the sport would be endeavouring to reduce its environmental impact. Prior to his promotion, Lynch was managing director of green innovation.

Jeremy Milless has been promoted to the post of chief engineer on the **Josef Newgarden** car at IndyCar squad Sarah Fisher Hartman Racing. He takes over the role from **Nathan O'Rourke**, who has moved on to rival team Andretti Autosport.

Billy Scott is now crew chief on the No 55 Toyota of **Brian Vickers** at NASCAR Sprint Cup outfit Michael Waltrip Racing. Scott, who has served as a lead engineer on the car for the past two seasons, has been at MWR since 2008.

Chief designer **Doug Skinner**, along with engineers **Matt Crawford** and **Scott Sinclair**, and operations manager **Adam Laws**, have all left crack V8 Supercars Australia team Walkinshaw Racing. It's understood the departures have come as a result of both resignations and redundancies.



Contract manufacturing of high value, high performance components to an international clientele in formula, sports car and rally competition.

Authorized sales, service and testing of Ohlins racing dampers.

Exclusive North American agents for Farrington data acquisition systems.

ECU/Exchange Loom/Throttle Body Packages available

Complex modern engine? We can manage it

ECU solutions for:
Honda S2000 and K20A
Ford ST170 and Duratec
Toyota 2ZZ
BMW Single / Twin VANOS
Audi 1.8T and 5 cylinder
Chevrolet LS7.



Our ECU's are capable of dealing with the most complex of modern engines without the need to change sensors or sacrifice key features such as variable camshafts.



Get the very best from
any engine and from only **£495.00 + VAT.**

DTAfast, 10 Boston Court, Kansas Ave, Salford M50 2GN
Tel: +44 (0)161 877 1419 Fax: +44 (0)161 877 7086
Email: office@dtafast.co.uk Website: www.dtafast.co.uk



CUSTOM BRAKE LINES | OIL COOLERS | HOSE | FITTINGS
ADAPTERS | FILTERS | NOS | FUEL PUMPS & REGULATORS



FUELAB NOS Holley EARL'S VEXEL WORKS STAUBLI

Visit www.earls.co.uk for the full range
Online Shop now Available

QUOTE "RCE10"
WHEN ORDERING TO
RECEIVE 5% DISCOUNT

Earl's Performance Products UK Ltd
Units 15-16 Silverstone Circuit, Northants, United Kingdom NN12 8TL

+44(0)1803 869850 | sales@earls.co.uk

DOCKING

Advanced Cooling Systems

Water Radiators
Intercoolers
Oil Coolers
Heat Exchangers
System Design
Ancillary Products

Manufactured to your requirements by the UK's leading supplier.

E info@dockingengineering.com

Tel 00 44 (0) 1327 857164

Fax 00 44 (0) 1327 858011

Website www.dockingengineering.com

Unit 15 Silverstone Circuit • Silverstone Northants • NN12 8TL • United Kingdom

OBITUARY - ANDY GRANATELLI

Well-known US motor racing entrant and sponsor

Andy Granatelli has died at the age of 90.

The former chief executive of STP was well known in both IndyCar and NASCAR circles thanks to the brand's



LAT

engine, but it is as a car owner that he gained his greatest successes, very nearly winning the Indy 500 with Parnelli Jones in a turbine-powered Studebaker in 1967 and again with Joe Leonard and Art Pollard in similarly-powered Lotus 56s the following year.

The breakthrough win was to come with Mario Andretti in 1969, this time with a more conventional Ford-engined Hawk. Granatelli celebrated the win by kissing Andretti on the cheek in Victory Lane, the iconic photograph of which cemented his place in Indy folklore.

IMS president Doug Boles said of Granatelli: 'Andy Granatelli understood better than anyone the spirit and challenge of the Indianapolis 500, and had a remarkable ability to combine innovative technologies with talented racecar drivers to make his cars a threat to win at Indianapolis every year.'

But it was not all Indy, and Granatelli went some way to changing the face of NASCAR with his high profile sponsorship of Richard Petty that lasted more than three decades, during which time the blue and orange of STP and Petty (a compromise as Granatelli originally wanted all orange as at Indy) became one of the most famous liveries in world motorsport.

Andy Granatelli 1923-2013

participation in the sport as a sponsor. But before he rose from flamboyant STP spokesman to become its boss, Granatelli had run an auto shop and then a race team with his brothers. He had also promoted fan-friendly races during the 1940s and had attempted to make his name as a driver, a career cut short after a heavy crash in qualifying for the 1948 Indianapolis 500.

In the 1950s he bought the rights to the Novi V8

BRIEFLY

Bully for Boullier

Eric Boullier has joined McLaren as racing director, reporting to new CEO Ron Dennis. Boullier will ultimately report to the CEO of McLaren Racing, an all-new position, whose yet-to-be-appointed occupant (as *Racecar* went to press) will in turn report directly to Dennis. 'Eric's appointment is an integral part of a senior management restructure within McLaren Racing,' said Dennis. Boullier added: 'I'm both eager and determined to play an active part, working alongside McLaren Racing's other senior managers and directors to bring about the changes that will deliver success.'

HPD Coupe

Honda Performance Development (HPD) is planning on building an LMP2 coupe, which is likely to see service from the 2015 season onwards. The motorsport department for Honda in the USA has said that the all-new design will replace its current open-top ARX-03b, with the aim of competing with LMP2 market rivals Oak and ORECA, which both announced closed car projects in the autumn. The new car is to be designed by UK-based Wirth Research - a traditional partner to HPD - and will be based on a tub built to the new LMP1 regulations.

RACE MOVES

Scott Sinclair has been appointed general manager, racing operations, at Nissan Motorsport's V8 Supercars team in Australia. Sinclair, who was race engineer for James Courtney during his championship-winning 2010 campaign, will replace **Rob Crawford** in the position. Crawford is quitting racing to return to his automotive repair business.

Patrick Louis is no longer CEO at the Lotus F1 team. He was brought into the team in 2010 when the current owner, **Genii Capital**, purchased it from Renault. Louis will now take a position with Genii Automotive, although he will remain on the Lotus team's board. **Mathew Carter** replaces Louis as CEO.

SPAL Automotive UK, the Worcester-based arm of SPAL Group, an Italian manufacturer of specialist fans and blowers, has appointed **Andy Clift** as business development manager for aftermarket sales.

NASCAR has reinstated former Sprint Cup Series crew chief **Todd Parrott** after he successfully completed its substance abuse policy's Road to Recovery programme. Parrott, most recently a crew chief at Richard Petty Motorsports, was suspended in October last year after a positive test at Charlotte Motor Speedway. He lost his position at RPM shortly after he failed the test.

NASCAR has also reinstated former Camping World Truck Series crew member **Marshall Foust** upon his successful completion of its Road to Recovery programme. Foust had been suspended from NASCAR in the autumn.

NASCAR Sprint Cup outfit Swan Racing has announced that **Randy Cox** and **Steve 'Bones' Lane** will



LAT

It's been reported that former Williams CEO and chairman **Adam Parr** (above) has taken up a position on the board at Cosworth. Joining Parr as new members of the Cosworth board are **Alan Donnelly**, formerly with the FIA in Formula 1, and **Carl-Peter Forster**, who was once chief executive at Tata Motors.

be its crew chiefs for the 2014 season. Cox will tend **Cole Whitt's** Toyota while Lane will look after the similar car of **Parker Kligerman**.

Richard Buck is the new NASCAR Sprint Cup Series managing director, taking over the role held by **John Darby** for the past 12 years. Darby moves to managing director, competition. Buck was previously vice president, racing operations, at IMSA and also managing director of NASCAR's Touring Series.

Dale Earnhardt Jr's crew chief at Hendrick Motorsports, **Steve Letarte**, is to leave the NASCAR Sprint Cup outfit at the end of the season to take up a position as a TV analyst at NBC Sports in 2015. Letarte, 34, has been at Hendricks all his working life, starting at the team when he was just 16.

■ Moving to a great new job in motorsport and want the world to know about it? Or has your motorsport company recently taken on an exciting new prospect? Then send an email with all the relevant information to Mike Breslin at bresmedia@hotmail.com

SPONSORSHIP

British Touring Car squad **Rob Austin Racing** has signed a two-year deal with fuel additive company **Fast Exocet** and the company's Exocet branding will adorn the team's lead Audi A4 throughout the 2014 season. Team owner and lead driver Rob Austin, who lost his 2013 sponsor **Wix Filters** just before Christmas, is also now offering shares in his team to the public.

45,000 Buyers • 1,200 Exhibitors • Over 72 Countries Represented

PRI 2014

Indianapolis

December 11-13, 2014 • Indiana USA
www.performanceracing.com

**Performance
Racing Industry**
TRADE SHOW



Where the Racing Industry
Gets Down to **Business**

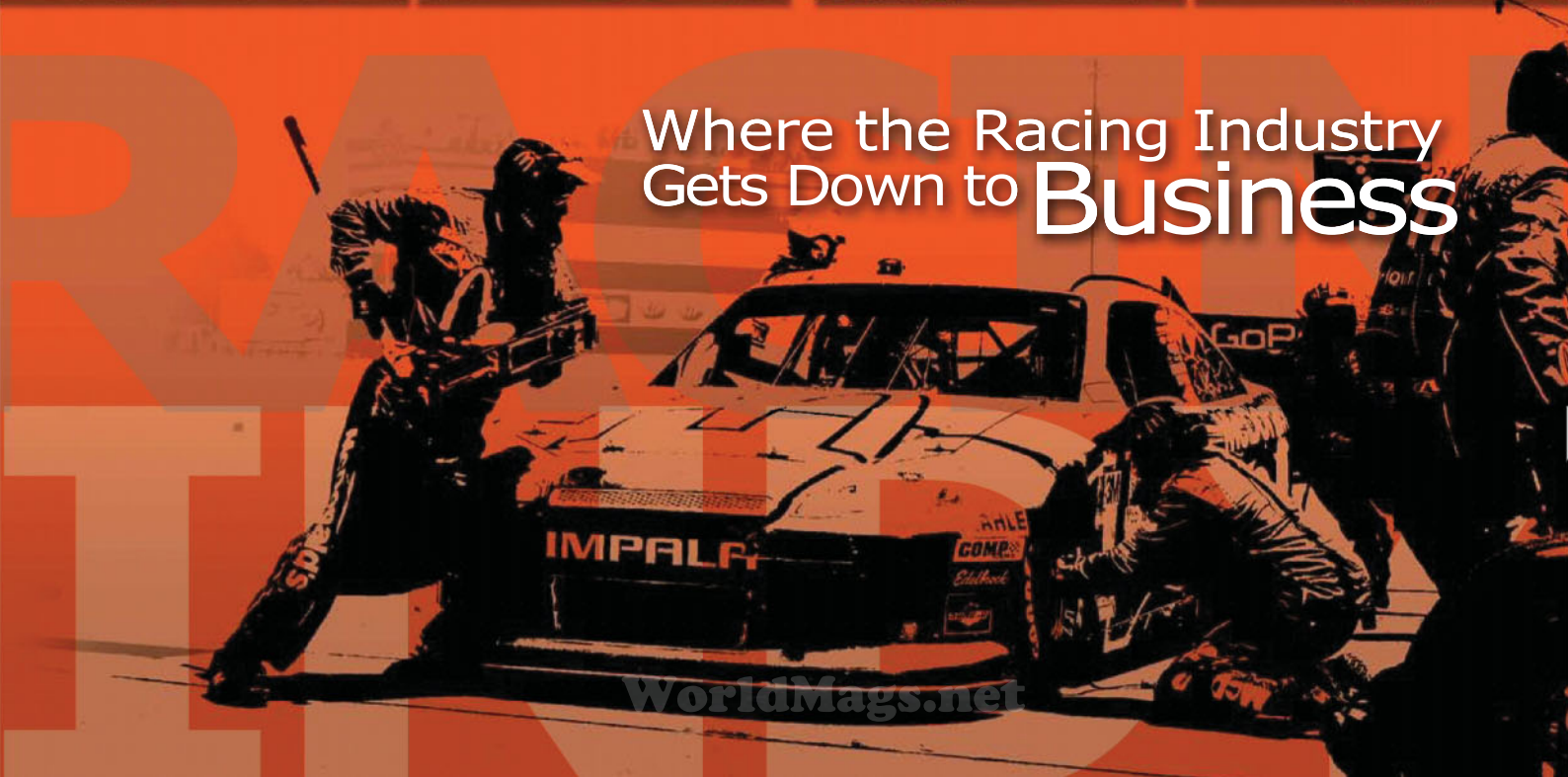

WorldMags.net

Williams strengthens Formula 1 technical team

Williams has continued its aggressive recruitment drive with a raft of key appointments to the technical ranks of its Formula 1 operation.

The signings include Jakob Andreasen, who has joined as head of engineering operations, and will now work under chief technical officer Pat Symonds. Andreasen was previously at Force India, and his focus will be on better

integrating trackside operations with the continued design and development of the new Williams-Mercedes FW36 at the factory.

Williams has also recruited Craig Wilson as head of vehicle dynamics and Rod Nelson as chief test and support engineer. Wilson returns to Williams from Mercedes to strengthen the engineering team in applying vehicle modelling and analysis to help bring further improvements to on-track performance. Nelson joins from the Lotus F1 Team to head up the team's testing programme, including leading the group at the factory that provides support and analysis from the team's Grove base for all race events.

Internally, Max Nightingale has been promoted to head of vehicle science to ensure a focus on performance within the new structure.

Pat Symonds said: 'Williams is determined to make strong improvements in our competitiveness over the coming seasons, and these new appointments continue our aggressive approach in recruiting some of the sport's best talent.'



OBITUARY – BRIAN HART

Acclaimed engine builder

Brian Hart has died at the age of 77. Hart started in motorsport as a driver and raced successfully in Clubmans, Formula Junior, Formula 3 and Formula 2 in the 1960s, before hanging up his helmet in the early-1970s.

Parallel to his racing exploits, Hart began a career in engineering in the late-1960s, working at the De Havilland aircraft factory before moving to Cosworth, which he left in 1969 to set up a company to service Ford Cosworth FVA engines.

Brian Hart Limited went on to design and develop the famous BDA for Ford, which was used in Ford rally Escorts at the height of their glory in the 1970s, while he also adapted the motor for use in Formula 2.

Hart also supplied F2 engines for the Toleman Group in 1979-1980, which subsequently led to a deal to supply the new Toleman F1 team with powerplants in 1981. Hart's best result in the back of an F1 Toleman was second at Monaco in 1984, with Ayton Senna at the wheel. But the morphing of Toleman into Benetton in 1986 meant a switch to BMW engines



and a departure from F1 for Hart - although the company did supply the Beatrice-Has team before its Ford engine was ready.

Hart returned to F1 with his own 3.5-litre V10 in 1993, supplying Jordan until the team switched to Peugeot in 1995. After this came a deal with Footwork/Arrows which led to Arrows boss Tom Walkinshaw acquiring Brian Hart Ltd in 1997, and Hart saying goodbye to the sport - while in turn the sport said goodbye to the last of its truly independent engine builders.

Brian Hart 1936-2014

BRIEFLY

F3 wings clipped

British Formula 3 has banned some of the aero appendages on older cars eligible for the new 2014 championship, so that they are on a par with the Dallara F312. Anyone running the F308 (or a similar vintage Mygale) will have to remove the bridge wing and front barge boards, plus the strakes from under the front wing, as well as the flip-ups in front of the rear wheels.

Andretti crosses codes

Andretti Autosport will widen its motorsport involvement this season by branching out into the Global Rallycross championship, where it will represent Volkswagen. The team will also be racing in its traditional arena of IndyCar this year, plus Indy Lights and Pro Mazda, as well as the new Formula E.

Ceram rewrap

Materials technology group Ceram is changing its name in order to reflect its expanding portfolio of businesses.

The Staffordshire, UK-based firm - which offers materials development, testing and analysis - will now be known as Lucideon.

Fabs management

Leading exhaust manufacturer Good Fabs has appointed its first general manager. Ross Allen joins the Long Crendon, UK company from Mercedes AMG, where he worked in strategic and technical buying roles. In this capacity, he was responsible for all the machined parts on the 2014 engine programme.

Pirtek gets its coat

Thermal protection specialist Zircotec has announced an extension to their deal with BTCC champions Pirtek Racing. Ceramic exhaust coating will appear on Andrew Jordan's car in 2014 to complement ZircoFlex heatshield, managing temperatures for increased performance. Pirtek started running with ZircoFlex midway through 2013.

Cosworth's new direction

Cosworth has announced the appointment of several new directors, chosen for their 'complementary expertise and experience in disciplines central to Cosworth's strategy for growth and development.' Joining as non-executive directors are Carl-Peter Forster, Adam Parr, Alan Donnelly and Zak Brown. The other directors are shareholders Kevin Kalkhoven and Jerry Forsythe, and chief executive Hal Reisinger.

Williams joins the grid

Williams Advanced Engineering, the division of Williams that commercialises Formula 1-derived technologies, is embarking on a project to install flywheel energy storage technology in two remote Scottish island communities to help stabilise their power grids, improve energy efficiency and reduce emissions from non-renewable power sources. The Isle of Eigg and Fair Isle will be the first sites

in Europe to install composite flywheel energy storage technology into their power networks.

Rally GB deal

Following the success of the new-look Rally GB, the Welsh government will continue to sponsor the event for a further two years. The extension of the £1.5m a year contract came in the wake of promising interim financial results following the move north to the race's new base at Deeside, rather than in Cardiff, the Welsh capital.

Bill Mitchell

The highly-respected engineer, software programmer and kinematics expert William C Mitchell, better known as Bill, died peacefully at his home in Mooresville, NC. In a lengthy association with motorsport, Mitchell created a host of programs including the acclaimed WinGeo3, which allowed the user to study how a suspension system would move under dynamic conditions.

PIT KIT

B-G Racing pit board kit and pit trolley

A pit board is a must-have in almost all forms of motorsport, and these new B-G Racing pit board kits have been created to fulfil the requirements of race teams by offering a choice of two different sizes.

Both kits include a full set of hi-visibility numbers and a protective carry bag that features internal pockets to keep the number set organised. The standard size aluminium pit board has been designed to be compact, yet unmissable to the driver. It features an ergonomic tubular frame and four rows for displaying information to the driver.

The larger pit board also features an ergonomic tubular

frame with an additional handle, four rows for displaying information and a top plate that can be used to personalise with a driver's name, number or team logo.

Both pit boards are manufactured from lightweight T6 aluminium and are finished with a durable bright silver anodised coating. The bags are produced from nylon fabric and feature a pair of removable and adjustable straps to make it easy to secure the bag to a pit wall.

Complementing the pit boards, B-G has also unveiled a new folding pit trolley, ideal for transporting wheels, tyres, tools and Euro bins around

the pits, paddock and workshop. One particularly attractive feature is that the trolley folds down for ease of storage and transportation.

The trolley can either be pulled by hand or attached to a paddock vehicle, and is manufactured from high-grade mild steel with a durable silver grey powder-coated finish. It is fitted with 100mm diameter swivel and brake front castors, and 100mm fixed rear castors.

www.bg-racing.co.uk



COMPANIES

Wirth Research

An innovative engineering company pioneering advanced virtual engineering technologies, Wirth's solutions have been developed in-house. This enables the use of a complete simulated design, research, development, manufacturing and testing process that reduces the need for

wasted development models and prototypes, reduces overall project timing and costs, and has created a string of record-breaking designs for motor racing and other high performance technology sectors. See the website for details of their flow simulation and CFD services. www.wirthresearch.com

HEAT MANAGEMENT

DEI 'Titanium' Protect-A-Sleeve thermal protection



Following on from DEI's recently released 'Titanium' spark plug boots comes Protect-A-Sleeve, which utilises the same Lava Rock technology to protect wires, lines and hoses from extreme heat. DEI claims that the sleeves will protect wires, lines and cables when exposed up to 1800degF (982degC) direct heat or 2500degF (1371 degC) radiant heat. These high-temperature-rated sleeves provide superior thermal protection for

street vehicles or race engines, protecting fuel, oil lines, spark plug and electrical wires.

The OJD sleeves will fit many of today's larger diameter spark plug wires for protection against hot exhaust manifolds and headers. The sleeving is available in 4ft lengths x 0.5-inch and comes complete with 10 high-temperature military-specification 3-to-1 shrink tubes to seal sleeve ends.

www.designengineering.com

CONNECTIONS

APEX Universal Joints

Trident Racing Supplies are now stockists of Apex military-specification universal joints complying to MS20271. Difficult to source for many years, the joints are found in military and aerospace applications, as well as performance racing for gear linkages, steering joints and starter shafts.

Trident make half-inch, 5/8-inch and 3/4-inch bore joints, and these highly regarded parts are designed to achieve maximum linear and axial load capacity with low deflection. They are pre-lubricated and have a sealed orange silicon rubber boot. www.tridentracing.co.uk



PLUMBING

Viper pipe fittings

Fluid connection specialists

Viper Performance recently unveiled two new products. First are new barbed connectors, which are ideal for fitting a flexible hose to a component or stainless steel AN fitting pipe run. They come with either male or female AN thread fittings on one end and a choice of barb fittings on the other. The fittings are machined from

6061 billet aluminium and are available in a choice of blue or black anodised finishes.

Viper has also released a one-way fuel system check valve for Bosch fuel pumps. The valve comes with AN DASH 6 or DASH 8 threads that are compatible with Bosch pump fittings, and are also machined from 6061 billet aluminium.

www.viperperformance.co.uk



PROTOTYPING

EOS M 400

Rapid prototyping specialist

EOS recently unveiled the M 400 additive manufacturing machine, suitable for research and development through to series production. Its 400x400x400mm build chamber allows the manufacture of larger components or more smaller parts to be produced simultaneously from metal powder layer by layer. The level of automation has also been raised, allowing for greater mass production.

The basic model will be available from spring 2014, with global distribution planned from the summer. Processes for further materials are still in the

development phase, including both tool steel and titanium, made possible thanks to the 1,000W output laser, allowing the use of materials that require more power. A touchscreen interface simplifies system usability. EOS has also optimised the monitoring and reporting functions for improved quality control.

In addition to the new machine, EOS has also release a new nickel-chrome-iron-molybdenum powder stock, called NickelAlloy HX.

The new material is designed for the construction of components that need to resist temperatures of up to 1200degC.

www.eos.info



MACHINING

SolidCAM InventorCAM 2014

SolidCAM's InventorCAM 2014 for Autodesk has been released, including various enhancements alongside a new measurement module.

Toolbox roughing and finishing operations have been added to the 2.5D Milling module, while threading and engraving operations have also been enhanced. In addition, the HSS module for surface machining has been upgraded with new lead-in ramping options. The application's 3D Milling solution, comprising the High Speed Roughing (HSR) and High Speed Machining (HSM) modules, has new algorithms

which provide additional strategies and benefits. These include Hybrid Machining, which makes use of faster multi-core calculations utilising the full power of the user's computer processors, and allows for smoother surface finishes.

The latest software also includes major enhancements to the Simultaneous 5-axis module. New tilting options have been added and improvements made to the SWARF, 5X Drill and Convert HSM to Sim 5X operation, which converts 3-axis machining to 5-axis machining. Sim 5X has three new powerful operations, while the new



multi-blade machining operation handles impellers and bladed discs, with multiple strategies for efficiently roughing and finishing every part of these complex shapes.

Of particular interest to engine builders, the port machining

operation is a new and easy-to-use method for machining ports with lollipop milling tools. Four strategies are provided to completely finish a port: roughing, rest rough, spiral and plunge finishing.

www.solidcam.com

PIT CREW

Editor

Andrew Cotton
 @RacecarEd

Deputy editor

Sam Collins
 @RacecarEngineer

News editor

Mike Breslin

Design

Dave Oswald

Chief sub editor

Stuart Goodwin

Contributing editors

Paul Van Valkenburgh

Technical consultant

Peter Wright

Contributors

Mike Blanchet, George Bolt jr,
 Lawrence Butcher, Charles Clarke,
 Marco De Luca, Ricardo Divila,
 Andrew Marina, Simon McBeath,
 Danny Nowlan, Mark Ortiz

Photography

LAT, John Brooks, Lawrence Butcher, XPB

Deputy managing director

Steve Ross

Tel +44 (0) 20 7349 3730

Email steve.ross@chelseamagazines.com

Head of business development

Tony Tobias

Tel +44 (0) 20 7349 3743

Email tony.tobias@chelseamagazines.com

Advertisement manager

Lauren Mills

Tel +44 (0) 20 7349 3740

Email lauren.mills@chelseamagazines.com

Advertisement sales executive

Stewart Mitchell

Tel +44 (0) 20 7349 3745

Email stewart.mitchell@chelseamagazines.com

Marketing manager

William Delmont

Tel +44 (0) 20 7349 3710

Email will.delmont@chelseamagazines.com

Publisher Simon Temlett

Managing director

Paul Dobson

Editorial

Racecar Engineering, Chelsea Magazine
 Company, Jubilee House, 2 Jubilee Place,
 London, SW3 3TQ

Tel +44 (0) 20 7349 3700

Advertising

Racecar Engineering, Chelsea Magazine
 Company, Jubilee House, 2 Jubilee Place,
 London, SW3 3TQ

Tel +44 (0) 20 7349 3700

Fax +44 (0) 20 7349 3701

Subscriptions

Subscriptions Department
 800 Guillat Avenue, Kent Science Park
 Sittingbourne, Kent ME9 8GU
 Telephone +44 (0) 1795 419837
 Email racecar@servicehelpline.co.uk
 http://racecar.subscribeonline.co.uk

Subscription rates

UK £66 (12 issues)

USA \$162 (12 issues)

ROW £84 (12 issues)

News distribution

COMAG, Tavistock Road, West Drayton,
 Middx UB7 7QE

Printed by Wyndeham Heron

Printed in England

ISSN No 0961-1096

USPS No 007-969



www.racecar-engineering.com

The shape(s) of things to come

The Daytona 24 hours was a place of entertainment and confusion in almost equal measure as we monitored Formula 1 launches, the apparent link of the DTM, Super GT and IMSA to create a global platform for manufacturer-led racing, while - on track - IMSA's balance of performance, renamed the adjustment of performance, became a hotly debated topic.

The new Formula 1 regulations have led, for the first time in a long time, to radically different designs and solutions. Under the skin, the cars are equally different as each tries to find the best solution. On the internet, the medium of comedy was very much in the air as the McLaren nose was Photoshopped on to the face of an elephant, Ann Summers tweeted that the Toro Rosso nose appeared to have been inspired by its range of sex products, and the Ferrari was compared to an Airbus A380 (OK, that last one was me).

Graphic designers tried to find ways to make these things look not quite so hideous, but as with the last major regulation change - where the front and rear wings looked as though they were made from Lego - this was a shock to the system. Actually, is it a bad thing? I thought we should celebrate this feature. For the first time in a long time, we will be able to distinguish clearly the different cars, even without their colour schemes. We have been hoping for this for a long time.

For the DTM link, there was also some comedy. While the ITR takes this all very seriously, and the Japanese are saying the right things in public, IMSA apparently banned there being any kind of press announcement during the 24 hours, despite there being one scheduled. Rumours that the ITR had demanded that the DTM cars be allowed to race in the main event may, or may not, be wide of the mark, but IMSA was spectacularly non-committal.

'We continue to have good dialogue between the parties and consider this a future opportunity for the North American motorsports landscape, though we're still very much in the educational process,' said Ed Bennett, CEO of IMSA. 'As our stakeholders would expect, our primary focus at IMSA for the past 18 months has been on the TUDOR United SportCar Championship and this weekend's 52nd running of the Rolex 24 at Daytona. We believe the opportunity to

compete on three different continents using the same racecars under common technical regulations is an attractive opportunity for automotive manufacturers, both domestic and foreign from this market.'

In short, we'll keep talking, but this is not a priority.

Unfortunately I also sat next to the Japanese delegation, who thought it very funny that they had taken the DTM rules, then applied their own engine rules, and allowed one of its three manufacturers to put the engine in the middle of the car. The fact that no one can agree on which hybrid system should be used (a common piece of equipment rather than manufacturers investing in their own) has led to just one running such a system (its own). There were also lots of serious faces among the organising team from Japan and Germany, and among the German manufacturers, but it all looked a bit comical.

The last piece of entertainment came from the adjustment of performance between the top classes competing in the TUSCC. In fairness, the GT LM and the GTD categories were not too badly balanced,

although the Daytona circuit suited fast cars, and therefore did not suit the Aston Martin Vantage or the BMW Z4. The bigger concern was the P2 and Daytona Prototype categories.

It was always going to be the case that the Daytona Prototypes would be faster, thanks to their higher top

speeds on the banking and therefore their ability to deal with traffic more efficiently than the P2s. The drivers worried about the performance differences, and extrapolated that to Sebring where, they reckoned, the DP would again be a better car. The organisers are doing their best to balance the performance, although Scot Elkins's claim that he was literally balancing apples and bananas seems unlikely. The fear is that he is not listening to the teams or the manufacturers. Elkins hoped that the race tactics would balance out over 24 hours, but the accidents and propensity to throwing yellow flags were always going to disrupt things. Therefore, the advantage was always with the Daytona Prototypes at Daytona.

It was the first race of the year, and if this is an indication of the season ahead, I am looking forward to it immensely.

EDITOR

Andrew Cotton

For the first time in a long time, we will be able to distinguish between the F1 cars

To subscribe to Racecar Engineering, go to
www.racecar-engineering.com/subscribe or email racecar@servicehelpline.co.uk
 telephone +44 (0) 1795 419837

Racecar Engineering, incorporating Cars & Car Conversions and Rallysport, is published 12 times per annum and is available on subscription. Although due care has been taken to ensure that the content of this publication is accurate and up-to-date, the publisher can accept no liability for errors and omissions. Unless otherwise stated, this publication has not tested products or services that are described herein, and their inclusion does not imply any form of endorsement. By accepting advertisements in this publication, the publisher does not warrant their accuracy, nor accept responsibility for their contents. The publisher welcomes unsolicited manuscripts and illustrations but can accept no liability for their safe return. © 2014 Chelsea Magazine Company. All rights reserved.

Reproduction (in whole or in part) of any text, photograph or illustration contained in this publication without the written permission of the publisher is strictly prohibited. Racecar Engineering (USPS 007-969) is published 12 times per year by Chelsea Magazine Company in England.

Brake control from green light to chequered flag.



Dominant victory for Pagid RS partner team Black Falcon and their drivers Bernd Schneider, Jeroen Bleekemolen and Khaled Al Qubaisi in the Mercedes SLS AMG GT3 at the 12h of Abu Dhabi.

Our „yellow pad“ (Pagid RS 19 and RS 29) has been the benchmark in endurance racing for many years. With the knowledge gained as the world's leading friction manufacturer, TMD Friction have developed an endurance racing brake pad which is even better: The new generation Pagid RSL1 has excellent modulation and release characteristics, as well as stable friction across a broad temperature range. Better still; the wear rate has been significantly improved to give you the race performance you need. With the highest degree of braking performance, PAGID RS brake pads deliver the competitive edge that drivers demand.



www.pagidracing.com · info@bremsentechnik.de
+ 49 6172 59 76 60

Pagid is a registered trademark of TMD Friction

TMD FRICTION
A NISSHINBO GROUP COMPANY

SO KRY SO JI → R2



WE CRAVE THOSE SURPRISE HAIRPINS TOO.



2014 Brake Supplier for
Renault Clio RS R3T

**RENAULT
SPORT**

PFC
BRAKES

www.pfcbrakes.com