



***Cutters Edge***<sup>®</sup>

***CE101C  
Gasoline  
Powered  
Concrete  
Saw***



***Cuts Reinforced  
Concrete Up to 16 Inches  
(41cm) Thick***

# Cutters Edge®

The CE101C Gasoline-Powered Concrete Chain Saw with GCP Premium SealPro® Diamond Chain cuts reinforced concrete up to 16 inches thick.

Unlike hydraulic saws, no heavy, bulky power pack is needed and there are no hydraulic lines to get in the way. And, unlike rotary saws, there

is no concrete dust produced and it can cut material that is twice as thick. Just a single water line with only a 2gpm flow (7.5 liters/min) at 20psi (1.5 bar) is needed to cool and lubricate the chain and prevent any concrete dust. A garden hose from a residential hose bib is all that is needed, but water can be supplied from any water source; including a pumper, tender, hydrant, standpipe, the ocean, a lake, stream or even a puddle or bucket of water. We also offer a **Concrete Sawing Kit** that includes a lightweight pump, hoses, adapters and everything needed to pump water from any source.

The CE101C cuts a wide range of materials, including reinforced concrete (rebar), masonry brick, concrete block, natural stone, and abrasive concrete. We developed a powerful 6.2 cu. inch (101cc) engine specifically for concrete cutting. An advanced crankshaft sealing, sealed throttle shaft, waterproof ignition, and a special air filtration system are just some of the features that allow this internal combustion engine to operate in the wet rescue concrete cutting environment.

### SCRENCH TOOL AND TOOL HOLDER

*This handy, universal tool can be used for all adjustments and maintenance of the Concrete Saw.*

### WALLWALKER®

*The pivoting of the Wallwalker® creates a 4:1 mechanical advantage by transferring forward pressure into downward pressure.*

### FLAME COATED GUIDE BAR

*With internal water galleries. 14" (36cm) or 16" (41 cm)*

### PIVOT "DOGS"

*The Pivot "Dogs" are hardened steel spikes that allow the saw to gain purchase in the concrete.*

**GCP PREMIUM  
SealPro™  
DIAMOND**

*Cuts reinforced concrete up to 16 inches thick.  
(See pg. 3 for details)*

### MULTI-STAGE AIR FILTRATION SYSTEM

*The Multi-Stage Air Filtration System is oil-coated to repel water and create a tack barrier. A fine mesh nylon screen adds an additional barrier.*

### 3 AXES 360° SWIVEL HOSE CONNECTOR

*The Swivel Hose Connector enables the saw to work freely through 360 degrees of direction in each of three axes. This keeps the water supply hose out of the way and prevents the hose from kinking.*

### FUEL MIX

*The 0.26 gal (1 liter) capacity fuel mix tank allows for 15 to 18 minutes of continuous full-load operation.*

### WATER PRESSURE GAUGE

*The Water Pressure Gauge shows the water pressure being delivered to the saw to ensure long chain life and prevents concrete dust.*

### STARTER SPRING LUBRICATION PORT

*The Starter Spring Lubrication Port allows lubrication of the starter pawls and springs without disassembly.*



**The CE101C Cuts Reinforced Concrete Up to 16 Inches Thick.**



## ***Additional Features of the CE101C Concrete Saw...***

### **FOAM COVERED FULL-WRAP HANDLE**

*The Full-Wrap Handle design allows the saw to cut in any position, even upside down and provides additional protection by acting as a "chain catch." The closed cell foam wrap reduces vibration and creates a non-slip surface for working in wet rescue environments*



### **RUBBER COATING**

*The entire bottom of the saw is coated with a layer of rubber to protect the saw from the abrasive concrete and to stop the saw from "walking."*



### **MOMENTARY ON/OFF CONTACT SWITCH**

*The momentary On/Off switch is always in the "On" position for reliable starting and to eliminate the possibility of flooding.*



### **FIRE GLOVE GRIP D-HANDLE**

### **MUFFLER EXHAUST PORT COVER**

*The Muffler Exhaust Port Cover prevents water from entering the engine through the muffler.*



# GCP Premium SealPro™ Diamond Chain

The Largest Diamond Segment Available for a Gasoline Powered Concrete Chain Saw and Cuts Reinforced Concrete Up to 16 Inches Thick

Micro-sized O-rings create a totally sealed rivet joint to keep out sand and slurry during concrete cutting. This unique design results in a longer chain life, reducing chain stretch and tensioning adjustments by up to 50 percent and reduces water pressure requirements to only 20 psi.

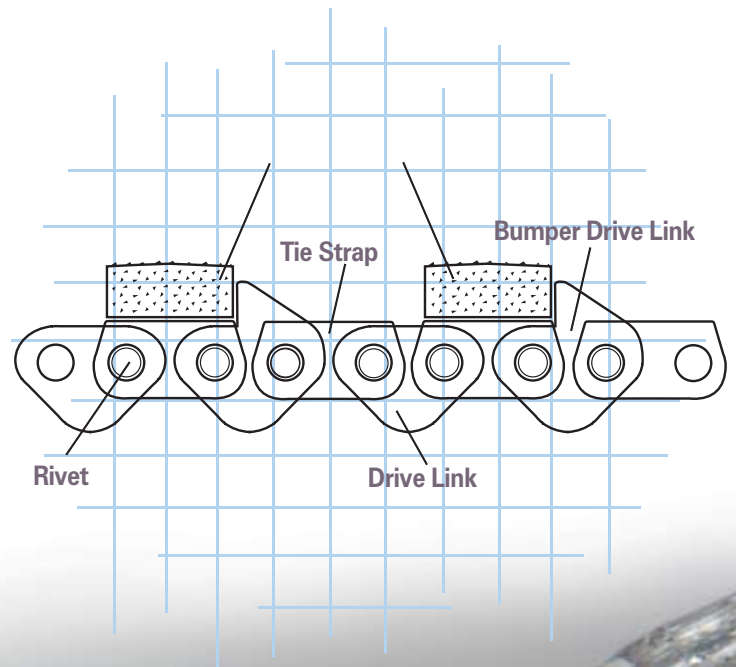
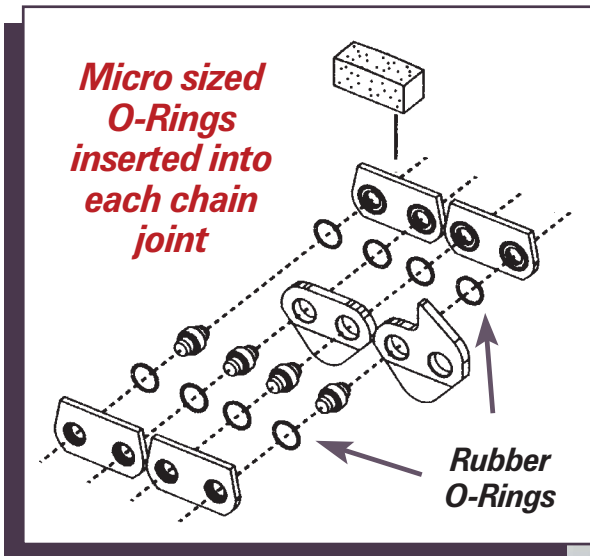

*Laser Welded*

*Thousands of Diamonds*

*No Kickback*

*Sealed Rivets*

**SealPro™**  
diamond chain

# CE101C Guide Bar



A flame coating creates maximum durability of the guide bar rails for longer life and smoother operation in the harsh environment of concrete cutting.

**Flame Coating and Internal Water Galleries for Long Life and Dust-Free Cutting.**

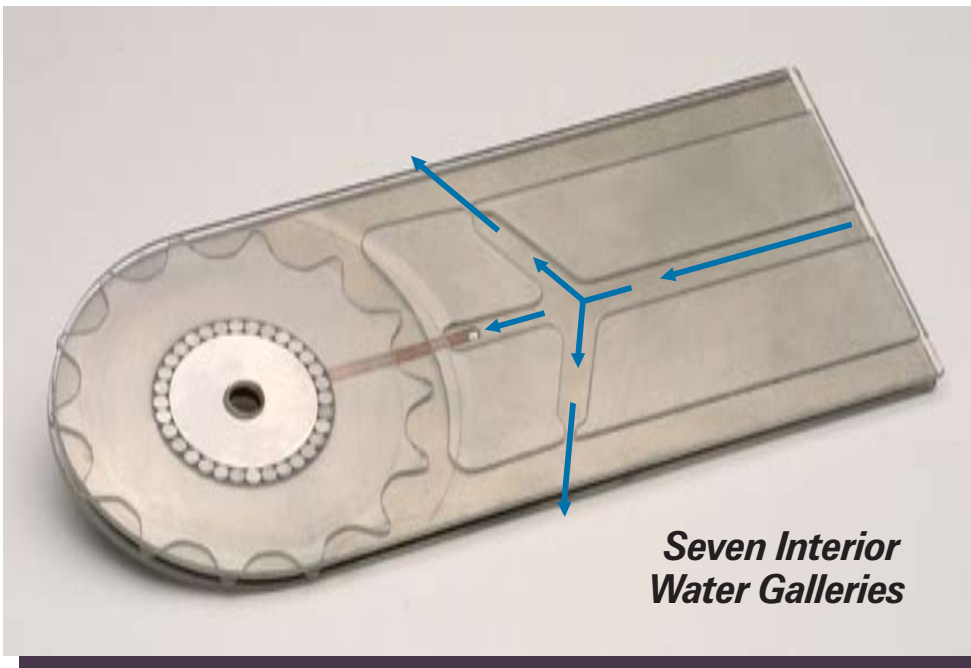

***Seven Interior Water Galleries***

Cool, dust-free cutting and bar and chain lubricating is the direct result of the unique, interior water galleries that deliver a constant pressurized flow of water from inside out to keep the diamond chain cool and prevent concrete dust.

***Available in 14" (36cm) and 16" (41cm) lengths.***



# The CE101C Concrete Sawing Kit

*Our Rugged 24-piece CE101C Concrete Sawing Kit Includes All of the Tools You'll Need to Cut Concrete Anywhere, Using Any Available Water Source.*

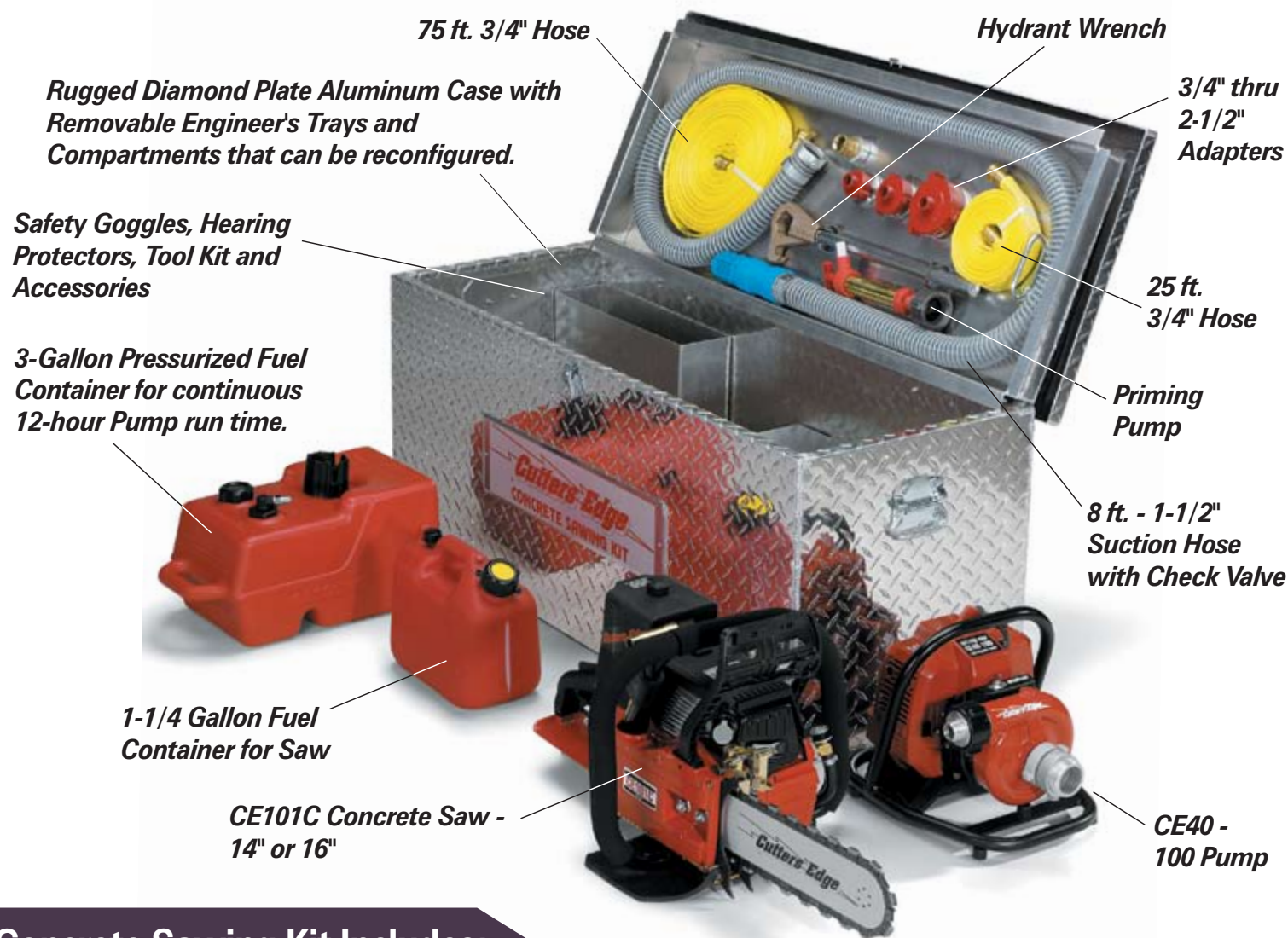

## Concrete Sawing Kit Includes:

- (1) Diamond Plate Aluminum Case with Dividers and Tray
- (1) CE101C/14" or CE101C/16" Gasoline Powered Concrete Cutting Chain Saw
- (1) CE40-100 Pump
- (1) 1-1/2" x 8 ft. Suction Hose
- (1) 1-1/2" Check Valve (Foot valve)
- (1) Hand Priming Pump
- (1) 1-1/2" Thread Protector (nps)
- (1) 1-1/2" (nps) Female x 3/4" (ght)\* Male Adapter/Thread Protector
- (1) 1-1/2" (nps) Female x 1-1/2" (nst) Male Adapter
- (1) 3/4" x 3/4" FHT Brass Hose to Hose Connector
- (1) 3/4" x 25 ft 250 psi Myti-flo Woven Hose
- (1) 3/4" x 75 ft 250 psi Myti-flo Woven Hose
- (1) 2-1/2" Female x 3/4" (ght)\* Male Adapter
- (1) 1-1/2" Female x 3/4" (ght)\* Male Adapter
- (1) 1" Female x 3/4" (ght)\* Male Adapter
- (1) Hydrant Wrench
- (1) 1-1/4" Gallon Fuel Container (UL Approved)
- (1) 3-Gallon Fuel Container (UL Approved) with 6 ft. Fuel Line, Primer Bulb and Quick-Connect Connectors, for up to 12 hours of Full Load Pump Operation.
- (1) 8 oz. Bottle, Cutters Edge 2-Cycle Oil Mix (Will make 6 Gallons of Fuel)
- (1) Air Filter "Recharger Kit"
- (1) Spray Can of Lubricant/Water Displacer
- (1) Tool Kit
- (1) Safety Goggles
- (1) Hearing Protectors

\* (ght) Garden Hose Thread

Specifications are subject to change without notice.

# CE101C Rescue Series Concrete Saw Specifications

## For CE101C/14" and CE101C/16"

- GCP Premium SealPro™ Diamond Chain
- Flame Coated Guide Bar
- Patented Pivoting WALLWALKER® System
- Pivot "Dogs"
- Closed Cell Foam Covered Full-Wrap Handles
- Momentary Contact On/Off Switch
- "Screch" Tool and Tool Holder Mounted on Handle
- Water Pressure Gauge
- 360 Degree Swivel Hose Connector
- Stainless Steel Muffler Exhaust Port Cover
- Air Filter "Recharger Kit"
- 8 oz. Bottle of Cutters Edge 2-Cycle Oil Mix
- Can of Water Displacer/Lubricant
- Deluxe Tool Kit and Instruction Manual
- 6.2 cu. inch (101cc) engine designed specifically for wet cutting concrete and an abrasive environment. Special crankshaft sealing and air filtration system.
- Lightweight Magnesium Castings
- Rubber Coated Bottom
- Starter Spring Lubrication Port

### Engine Type

2-Stroke Single Cylinder Air Cooled

### Displacement

6.2 cu. in (101cc)

### Horsepower

6.5 HP @ 8700 RPM

### Engine Speed

11,500± 500 RPM, mechanically governed  
2500-2800 RPM Idle

### Chain Speed

5500 fpm (28 m/s), free running

### Weight

27.2 lbs (12.3 kg)

### Cutting Depth

14 inches (36cm)  
16 inches (41cm)

### Dimensions

Length 25 inches (63cm)  
Height 14 inches (36cm)  
Width 12 inches (30cm)

### Carburetor

Walbro WGAK3, Throttle shaft sealed

### Starter

Dust and water shielded with lubrication port

### Ignition

Special water resistant electronic ignition

### Clutch

Three-weight, single spring, water and concrete proofed  
Rim and drum drive sprocket

### Fuel Capacity

0.26 gal (1 liter) 15 - 18 minutes per tank, continuous full-load operation

### Water Supply

20psi (1.5 bar), 2gpm (7.5 liters/min) minimum

### Noise Level

102dBA @ 1 meter

### Vibration Level

8 meters/sec (front handle)

### Cutting Rate

#### **Hard Aggregates & Steel:**

15-25 in/min (90-160 cm/min)

#### **Medium Aggregates:**

20-30 in/min (160-190 cm/min)

#### **Masonry, Block, Brick:**

30-50 in/min (190-320 cm/min)

*Specifications are subject to change without notice*



*Division of Edge Industries, Inc*

PO Box 8463855 | 23rd Street  
Baker City, Oregon 97814 USA  
Toll Free (US / Canada): 1-(800) 433-3716  
Telephone: (541) 524-9999  
International: +1-(541) 524-9999  
Fax: 1-(541) 524-9996  
Fax: +1 (541) 524-9996  
Email: info@cuttersedge.com

**[www.cuttersedge.com](http://www.cuttersedge.com)**



# **GASOLINE POWERED CONCRETE CUTTING CHAINSAW**

# **CE 101C**

Owners Manual

***Cutters Edge***<sup>®</sup>  
FIRE RESCUE SAWS  
Division of Edge Industries, Inc.

**P.O. Box 846**  
**3855 23rd Street**  
**Baker City, Oregon 97814**  
**Telephone: 541-524-9999**  
**Fax: 541-524-9996**  
**Email [info@cuttersedge.com](mailto:info@cuttersedge.com)**



## OWNERS MANUAL INTRODUCTION

Congratulations on purchasing a gasoline powered, concrete cutting chain saw. Used properly, this tool is a valuable asset. It will cut any concrete type construction material including brick, block, stone, masonry, and steel reinforced concrete. It can cut 12 inches deep and will cut square corners without overcuts.

Everything you will need to know about the basic operation and maintenance of this tool is described in this manual.

Any service or repair not covered in this manual should be performed by an Authorized Dealer.

### WARNING:

**Do not operate this tool without first reading this manual. Pay special attention to the safety and warning portions. Failure to follow these instructions could result in injury or death to the operator or bystanders.**

Do not remove any of the safety devices included on the saw. Remember, any cutting tool can be dangerous if misused or if appropriate precautions are not taken.

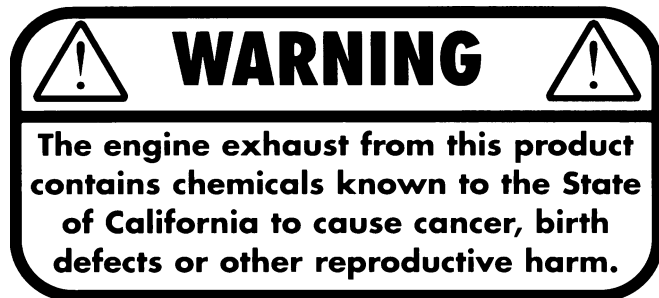

## Model CE101C Table Of Contents

Cover .....	1
Introduction .....	2
Table of Contents .....	2
Safety Information.....	3
Saw Description .....	4
Saw Technical Specifications.....	5
OPERATING INSTRUCTIONS	
Bar and Chain Installation.....	5
Carburetor Adjustment.....	6
Fuel Mixture .....	6
Starting the Saw.....	6
Chain Brake.....	6
CUTTING INSTRUCTIONS	
Before Starting The Cut.....	7
Planning The Cut.....	7
Wallwalker® .....	7
Water Pressure.....	8
Factors Affecting Chain Life.....	8
Economic Tips.....	8
System Clean Up .....	9
MAINTENANCE	
Air Filter .....	9
Fuel Filter, Cylinder Fins .....	9
Spark Plug, Starting Unit.....	10
Bar Maintenance.....	10
Drive Sprocket Replacement.....	10

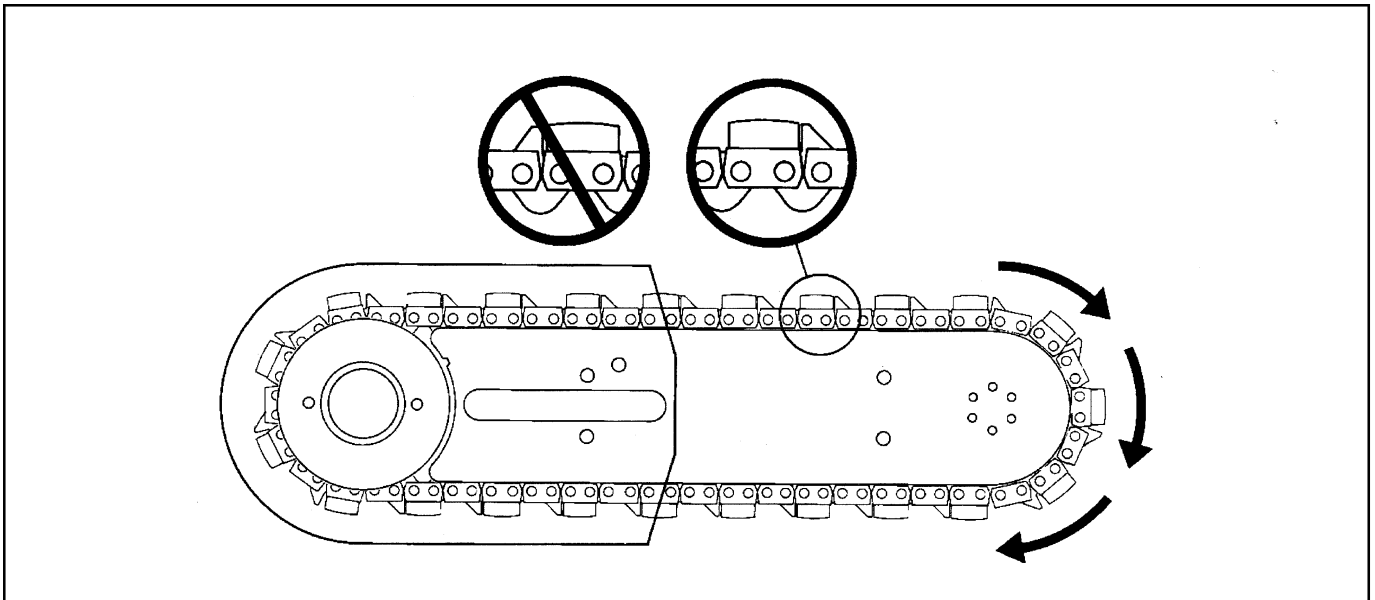

Figure 1 (Bar and Chain Drawing)

## WARNING:

**Failure To Follow These Safety Instructions Could Result In Injury Or Death To The Operator Or Bystanders.**

## SAFETY INFORMATION

### WEAR PROTECTIVE CLOTHING AND EQUIPMENT

- Hard Hat, Eye Protection, Hearing Protection, Gloves, Face Shield, Safety Shoes.
- Avoid loose fitting clothing.

### WORK IN A CLEARED AREA

- No obstructions (plumbing, electrical conduit, air ducts)
- No unnecessary people nearby. Well-marked safety zone. Roped boundary.
- Operate tool with solid footing and grip. Remove excess slurry on ground.
- Ensure proper ventilation of exhaust gases.
- Avoid electrocution – check for live electrical wiring in the cutting area.
- Be aware of the water hose to avoid tripping.

### SAFE SAW OPERATION

- Never operate saw without side cover securely in place.
- Never operate saw with a damaged, modified or broken side cover.
- Never run the chain backwards. Bumper should always lead the segment into the cut. (Figure 1)
- Never insert the saw into a precut slot that is narrower than the chain as rapid push back of the tool toward the operator may occur.
- Never carry or service the saw with the engine running.
- Never use damaged, modified or improperly repaired chain.

- Use caution when refueling. Turn engine off before refilling. Keep away from open flame. Move saw at least 10 ft (3 m) away from refueling area before starting.
- Never conduct any maintenance on the saw with the saw running. Turn saw off first.
- Use minimum 20 psi (1.5 bar) water pressure. Insufficient water supply results in excessive chain wear which weakens the chain and can lead to chain breakage.
- Maintain cutting system regularly.
- Keep the handles dry, clean and free of oil or fuel mix-

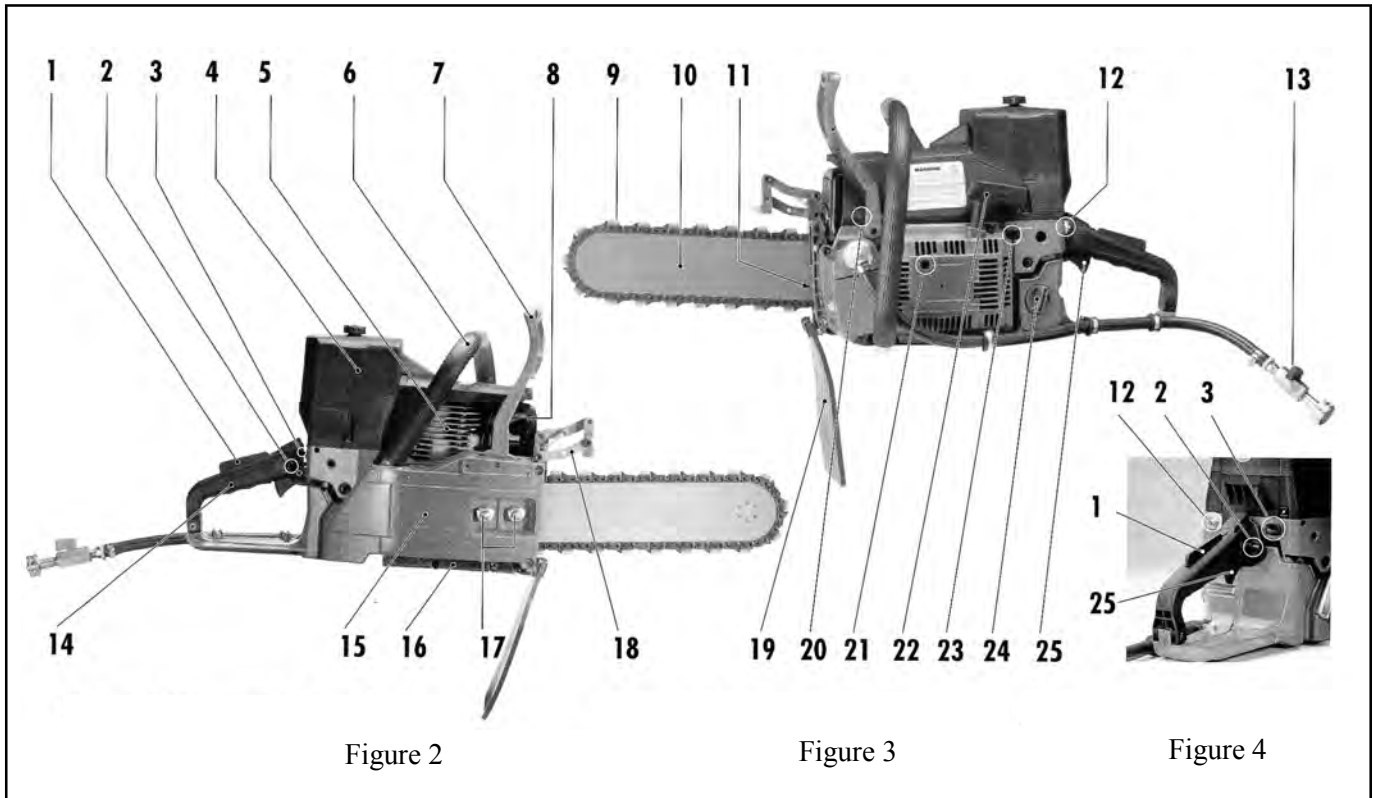

Figure 2

Figure 3

Figure 4

ture and slurry.

#### SAW COMPONENTS

- |   |   |
|---|---|
| <ul style="list-style-type: none"> <li>1. Throttle Interlock</li> <li>2. Throttle Lock</li> <li>3. Choke Control</li> <li>4. Air Filter Cover</li> <li>5. Cooling Fins</li> <li>6. Front Handle</li> <li>7. Chain Brake/Hand Guard</li> <li>8. Exhaust Muffler</li> <li>9. Chain</li> <li>10. Bar</li> <li>11. Chain Tensioner</li> <li>12. On/Off Switch</li> <li>13. Water Valve</li> </ul> | <ul style="list-style-type: none"> <li>14. Rear Handle</li> <li>15. Side Cover</li> <li>16. Cover Bottom</li> <li>17. Side Cover Nuts</li> <li>18. Wallwalker®</li> <li>19. Guard Flap</li> <li>20. Chain Brake Arm Release Snap</li> <li>21. Starter Spring Lubrication Port</li> <li>22. Starter Handle</li> <li>23. Carburetor Adjustment Screws</li> <li>24. Fuel Tank Cap</li> <li>25. Throttle</li> </ul> |
|---|---|



## SAW TECHNICAL SPECIFICATIONS

Engine.....	2 Stroke
Displacement .....	101cc (6.2ci)
Carburetor.....	Diaphragm type
Fuel.....	4% Mixture (25:1)
With Cutters Edge Synthetic .....	1% Mixture (100:1)
Fuel Capacity.....	1 Liter (34oz)
Ignition .....	Selettra electronic
Clutch .....	Centrifugal
Spark Plug .....	Champion CJ7Y or Bosch BWS7F
Cutting Length.....	12" (30cm) 14" (36cm)
Weight with bar and chain.....	27.5 lb (12.5 kg)
Noise.....	102 db @ 1 meter
Vibration.....	8 m/sec
Anti-Vibration Handles .....	Yes
Chain Brake.....	Yes
Water Requirements .....	20 psi (1.5 bar)
Maximum .....	160 psi (11 bar)
Engine Break-in Period .....	One tank of fuel at reduced feed load.

## BAR AND CHAIN INSTALLATION

NOTE: Numbers refer to figures 2, 3 & 4, (Page 4)

1. Disengage and disconnect Chain Brake Hand Guard (#7), loosen Cover Nuts (#17) and remove Side Cover (#15).
2. Move adjustment pin all the way back towards the sprocket using the srench tool or screw driver, turning tensioner adjustment screw counterclockwise.
3. Install the bar onto the mounting studs and adjustment pin.
4. Fit the chain onto the sprocket then into the groove of the bar.  
Check for proper chain orientation. The bumper drive link should lead the segment into the cut. (See Figure 1)
5. Reinstall the side cover, tightening the side cover nuts with fingers only.
6. Tension the chain by using the srench tool or screw driver to turn tensioner adjustment screw clockwise. Do not over tighten. Chain should not hang completely out of the bar but must be able to be pulled around the bar by hand.

## WARNING:

**Always pull chain away from Wallwalker® Point (#18)**

7. Firmly tighten the side cover bolts. Verify chain tension, adjust as necessary.

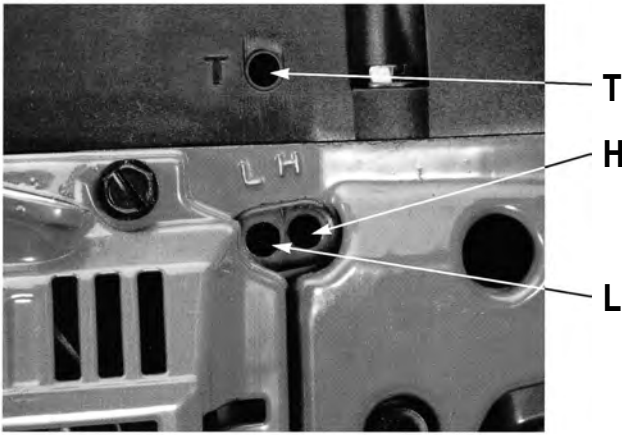

Figure 5

## CARBURETOR ADJUSTMENT

Before adjusting the carburetor, clean and replace the air filter, start and warm up the engine. The carburetor is adjusted at the factory. The factory settings are: Screw L (open 1½ turn) and Screw H (open 1 turn).

**T** – Idle Screw is adjusted so that the engine idles smoothly but the clutch does not engage.

**L** – Low Speed Screw is adjusted so that the engine promptly responds to sharp acceleration but operates smoothly at low RPM.

**H** – Hi Speed Screw is adjusted so that the engine produces maximum power during the cut.

**Tip** – Weather conditions and altitude may affect carburetion.

**Tip** – If saw has been running satisfactorily and there is a gradual decrease in power and RPM at full throttle, the filter may have become contaminated with water. Dry or change the filter.

## OPERATING INSTRUCTIONS

**FUEL MIXTURE:** Use Cutters Edge Synthetic 100:1 Gasoline/Oil Mixture.

If any other brand of two-stroke oil, 25:1 Gasoline/Oil Mixture.

Use regular gasoline with minimum octane rating of 90. Improper fuel mixture can cause engine damage. Mix fuel thoroughly before refueling. Always use a clean container.

## WARNING:

**Turn engine off prior to refueling. Never smoke while refueling or expose to open flame.**

## STARTING THE SAW

Note: Numbers refer to Figures 2, 3 & 4 (page 4)

### COLD SAW

- Toggle ON/OFF Switch (#12) to the left and pull out the Choke Control (#3)
- Lock throttle in start position: Depress Throttle Interlock (#1), depress Throttle (#25), depress and hold Throttle Lock (#2), while releasing Throttle (#25). Pull Chain Brake (#7) back towards the Front Handle (#6). Open Water Valve (#13) ¼ turn.
- Place saw on the ground making sure the chain is free of any obstructions. Place right foot on the base of the Rear Handle (#14). Place left hand on Front Handle (#6). With right hand, slowly pull Starter Handle (#22) until resistance is encountered, then give a short strong pull on the Starter Handle. Allow the starter rope to rewind and pull again as necessary. As soon as the engine fires, push the Choke Control (#3) back in. Continue to pull starter as necessary. When engine starts, depress Throttle (#25) to unlock and allow saw to idle. Depressing and releasing the throttle several times will help warm up the saw. Fully open water valve prior to cutting.

### WARMED UP SAW

- Toggle ON/OFF Switch (#12) to the left and pull the Starter Handle (#22). It is not necessary to use the choke or throttle lock. If choke is used, the carburetor will flood with gas. To recover, push Choke Control (#3) in, lock Throttle (#25) open, and pull Starter Handle (#22) until engine starts.

### STOPPING THE SAW

- To turn the engine off, toggle ON/OFF Switch (#12) to the right, “Stop” position. Close water valve.

### CHAIN BRAKE

- The Chain Brake (#7) is a safety device designed to protect the operator if the nose of the bar catches on something while running, which could cause the saw to kick upwards and backwards. If the Chain Brake is in the forward position, the chain will not move. To reset, pull the Chain Brake Lever back towards the Front Handle (#6).

## BEFORE STARTING THE CUT

- Ensure proper chain installation. (See Figure 1)
- Ensure all safety devices are properly mounted and functional and that all controls are in good working order.
- Clear the floor of the work area to minimize the potential to trip.
- Clear the work area of all bystanders.
- Wear ear protection, goggles and face shield, non-slip safety boots, gloves, and avoid loose fitting clothes.
- Turn water supply on. Minimum pressure of 20 psi (1.5 bar) is required, 160 psi (11 bar) maximum. Use of a booster pump may be required.
- Strictly follow all other safety items on page 3.

## PLANNING THE CUT

### WARNING:

**Plan Each Cut Carefully. Be Sure Cut Concrete Cannot Fall and Injure Operator or Bystanders. Concrete Is Very Heavy, One Cubic Foot (12" x 12" x 12") = 150 pounds. (30 cm x 30 cm x 30 cm) = 68kg.**

- Outline each cut with a permanent marker as a visual cutting guide.
- To avoid pinching the bar and chain, always cut the bottom of the opening first, then the sides, then the top.
- For long vertical or horizontal cuts, score the cutting line with the nose of the bar from 1" (25mm) to 2" (50mm) deep. This groove will guide the bar and help make a straight cut.
- Make sure there is nothing on the other side of the wall that the saw could come in contact with, especially electrical conduits or wires. Also, make sure the other side of the wall is clear in case the cut piece of concrete falls that way.

### WARNING:

**Inserting The Tool Into A Pre-Cut Slot That Is Narrower Than The Chain May Cause Binding And Rapid Pushback Of The Tool Toward The Operator, Which Can Cause Loss Of Footing And Result In Personal Injury.**

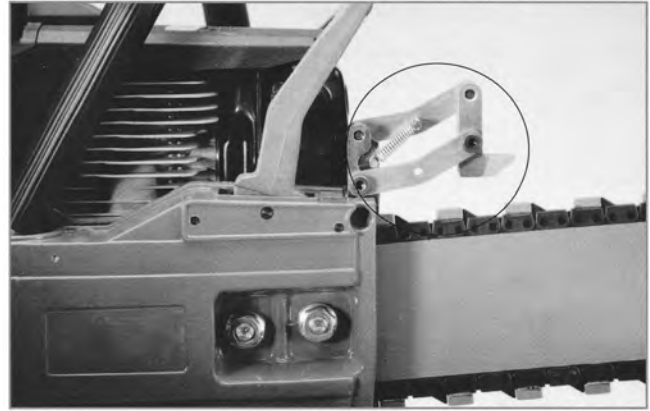

Figure 6 (Wallwalker)

### WALLWALKER®

The Wallwalker® (#18) is a very efficient device designed to give the operator mechanical advantage and create feed force. Sometimes the operator cannot simply push or pry the saw down the intended line of cut with enough feed force to cut satisfactorily. By using the Wallwalker, the required feed force can be achieved.

### WALLWALKER OPERATION

- Make a plunge cut the full length of the bar. Lengthen the cut by moving the saw body down the line of the cut.
- Insert the wedge of the Wallwalker into the cut and push the saw body directly toward the wall. As the Wallwalker begins to rotate up, feed force is developed down the line of the intended cut. The force will increase as the Wallwalker reaches the end of its stroke. When the Wallwalker bottoms out, pull the saw a few inches out of the cut and allow the Wallwalker to spring back. Re-engage the wedge into the cut and repeat.



## **WATER PRESSURE**

*The single, most important factor an operator can control to increase chain life is to use 20 psi (1.5 bar) or greater water pressure, 160 psi (11bar) maximum. A water booster pump may be required.*

## **FACTORS AFFECTING CHAIN LIFE**

### **Fast Wear, Short Life**

- Water Pressure less than 20 psi (1.5 bar).
- Hard Aggregates: flint, chert.
- Steel Reinforcing: heavy rebar.
- Aggregate Size: large rocks.
- Sand Shape: sharp, quarried.
- Concrete Age: less than 2 days old.
- Cutting Mode: plunge cutting.
- Cutting Direction: horizontal.

### **Slow Wear, Longer Life**

- Water Pressure:  
Greater than 20 psi (1.5 bar)  
160 psi (11 bar) maximum.
- Soft Aggregates: limestone, marble.
- Steel Reinforcing: none or wire mesh.
- Aggregate Size: small rocks
- Sand Shape: round, river
- Concrete Age: cured, 30 days old
- Cutting Mode: slab cutting
- Cutting Direction: vertical

## **ECONOMIC TIPS**

### **HOW TO GET THE MOST VALUE FROM YOUR DIAMOND CHAIN SYSTEM**

1. Use water booster pump that generates greater than 20 psi (1.5 bar), 160 psi (11 bar) maximum.
2. Minimize number of plunge cuts.
3. Expect less life in cutting steel reinforcing.
4. Check and maintain proper chain tension in use.
5. Use “guides” for ensuring straightness and reducing side loads when making cuts longer than 3 feet (1 meter).
6. For long vertical or horizontal cuts, score the cutting line with the nose of the bar from 1” (25mm) to 2” (50mm) deep. This groove will guide the bar for a straight cut.
7. Use the Wallwalker® to maintain constant feed force, minimize vibration and reduce impact to diamond segments.
8. Turn bar over to extend bar life.
9. Spray a lightweight oil on the bar and chain to prevent rust in storage.

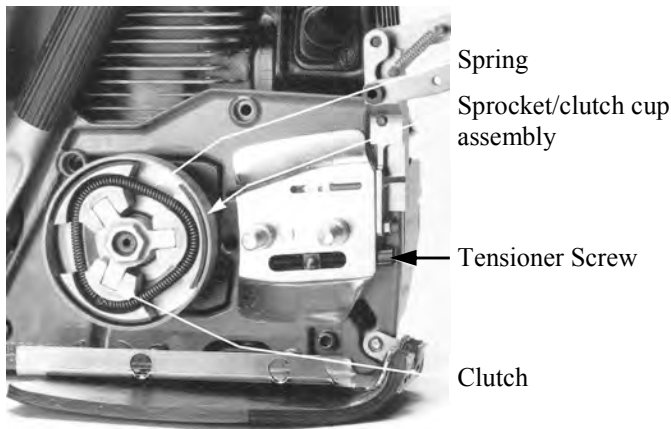

Figure 7

### SYSTEM CLEAN UP

1. Run saw for at least 15 seconds, with the water on, out of the cut to flush slurry and debris from chain, bar and drive sprocket area.
2. Wash concrete slurry from saw assembly using water.

### CAUTION: AVOID GETTING ANY WATER IN THE CARBURETOR OR EXHAUST SYSTEMS.

3. Remove bar and chain. Flush out chain tensioner with water.
4. After cleaning saw, spray entire saw body, chain, bar and drive sprocket with lightweight oil. This will minimize rust and reduce slurry build up on the saw and components.

## MAINTENANCE

### WARNING:

**Never Perform Any Maintenance On The Saw With The Saw Running. Turn The Saw Off First.**

#### BEFORE THE FIRST USE OF THE SAW:

- Oil the air filter. Remove the air filter and using the supplied bottle of air filter oil, squeeze a bead of oil along the full length of each pleat. Allow 15-20 minutes for the oil to wick. Touch up any un-oiled areas.

Note: Excessive oiling is not recommended.

Air Filter, Figure 8

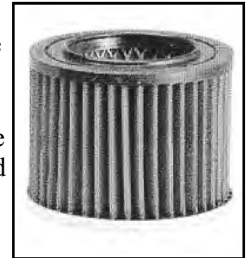

#### BEFORE EVERY USE:

- Visually inspect to verify the following items are securely fastened and are in proper operating condition: Guard Flap, Cover Bottom, Side Cover, Throttle Interlock, Throttle, Choke Lever, Wallwalker® and On/Off Switch. Tighten any loose parts. Replace any broken or missing parts.
- Check that bar, chain and sprocket are not worn out. Replace as necessary.
- Check that chain is properly tensioned.

#### AFTER EVERY USE, DAILY

- Spray saw, bar and chain with lightweight oil.

#### PERIODICALLY (EVERY 20 HOURS USAGE)

- Grease the Drive Sprocket Bearing.
- Check fuel filter located inside the fuel tank. Clean or replace if clogged.
- Oil Starter Spring. Open Starter Spring Oil Port by positioning slot vertically (Fig. 10). Apply several drops of lightweight oil. Close port after oiling.
- Clean Spark Plug and adjust electrode gap to .020in (.5mm). Replace if necessary.
- Clean starter drive pawls.
- Clean air filter using warm, soapy water. Do not use high pressure water or air. Rinse the filter from the inside out. Dry all parts of the filter. Prior to use, filter must be re-oiled.
- Clean chain tensioner pocket.

## BAR MAINTENANCE

- The Guide Bar is designed to be used on both sides. For even wear, turn the bar over as needed.
- Spray chain and bar with lightweight oil for storage.
- Proper chain tension will extend bar life.
- Under some circumstances, especially low water pressure, the sprocket nose can wear out before the bar body. Sprocket nose replacement kits are available at an Authorized Dealer.
- A table mounted belt sander can be used to square up the rails of a worn bar. A badly worn bar can quickly damage an expensive diamond chain. If the chain is touching the bottom of the bar groove, replace the bar.
- Check the bar for straightness. Bend slightly to adjust as necessary.
- Periodically clean the water ports inside the groove of the bar using a small diameter piece of wire. Water port cleaners are available from an Authorized Dealer.
- The bar is solely a guide track for the chain. Never use the bar to lift, twist or pry.
- Store bar with the sprocket nose up.

## DRIVE SPROCKET REPLACEMENT

The drive sprocket needs to be replaced before a groove cuts through the tops of the sprocket teeth, otherwise severe damage will occur to the chain.

1. Remove bar and chain. Remove clutch dust shield.
2. Remove spark plug and insert piston stop (supplied with each saw) as shown in Figure 10. Using a 19mm socket, remove centrifugal clutch in a clockwise direction. An impact wrench may be helpful. See Figure 11.
3. Carefully slide the clutch cup/drive sprocket assembly off the shaft. Save the needle bearing between the shaft and sprocket.
4. Apply a liberal amount of waterproof grease on the shaft and pack the needle bearing (grease supplied in sprocket replacement kit). See Figure 12.
5. Slide thin metal washer onto shaft, slide needle bearing onto shaft, then slide new sprocket/clutch cap assembly onto bearing.
6. Replace centrifugal clutch (counter clockwise rotation). Torquing is not necessary as starting the saw will automatically tighten the clutch. Replace clutch slurry shield.



Figure 10



Figure 11

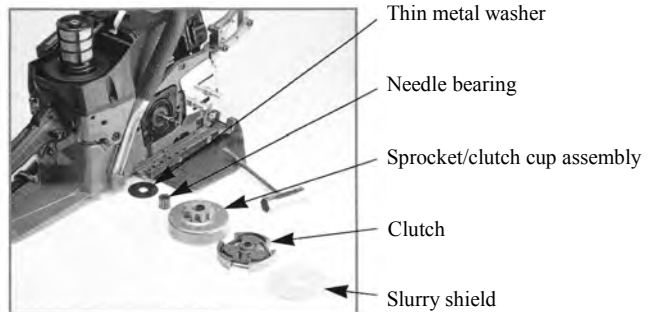

Figure 12



# CHAIN TENSION PROCEDURES

## PROPER CHAIN TENSIONING

When it comes to chain tensioning, concrete-cutting chainsaws are not like wood cutting chainsaws. The chain tension requirements are different. Concrete-cutting chainsaws run with chain tension that is not as tight as wood chainsaws. It is common, especially on gas-powered, concrete-cutting chainsaws to have the drive links hang completely out of the bar.

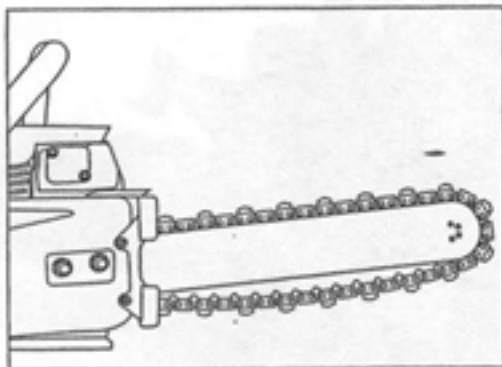

Wood-cutting chainsaws use oil to lubricate the chain. The oil makes the chain very slippery and allows the drive links to fully nest between the teeth of the drive sprocket. Concrete-cutting chainsaws require water for cooling and flushing the cut. However, water is not as good as oil as a lubricant. Plus there are concrete particles mixed in with the water. As a result, sometimes the drive links do not nest properly on the drive sprocket. When this happens, the chain acts like it got tighter. There seem to be "tight" spots and "loose" spots as you pull the chain around the bar. The chain has to turn a sharper corner which makes it more difficult to nest properly.

For best operating performance, chain life and operator safety, proper chain tension is very important. If the chain is too loose, it could come off the bar, or allow the drive sprocket to spin without turning the chain which can damage the chain drive links. If the chain is too tight, a lot of the saw's power goes into turning the chain rather than making the cut. In extreme over-tightened cases, the saw may not be able to turn the chain at all. In addition, an extreme over-tightened chain may damage the bar nose and premature stretch may occur.

## WHEN TO TENSION

All-chains have a tendency to stretch when used. Concrete-cutting chains are more susceptible to stretch than wood cutting chains because of the abrasive materials they are cutting. When a chain stretches to a point where the drive links are hanging approximately

1/2" (12 mm) to 3/4" (18 mm)\*\* below the guide bar, it's time to tension the chain.

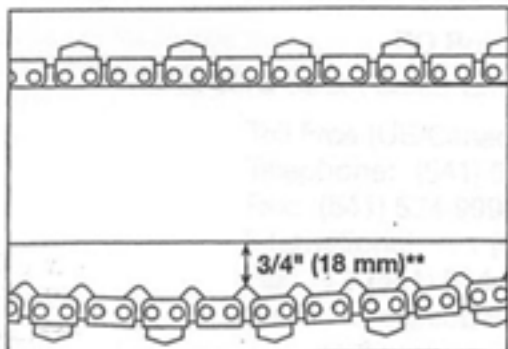

\*\* As measured without pulling downward (eg. hanging by gravity)

## HOW TO TENSION

To tension the chain, first loosen the side cover nuts, then while holding the nose of the bar up, use a screw driver to turn the tensioning screw clockwise until the chain drive links hanging below the bar are just beginning to enter the bar groove. Continue to hold up on the nose of the bar and firmly tighten the side cover nuts; (20 ft-lbs, 27 Nm). And remember, it's the side cover nuts that hold the bar in position. If the nuts are not tight, the bar can slip backwards during cutting and break the tensioner pin. Before cutting, check for proper tension by pulling the chain around the bar by hand. If you cannot easily pull by hand, the chain is too tight and needs to be loosened a little. A properly tensioned chain will optimize cutting performance. The tensioning rule of thumb for a concrete cutting chain saw is: "A properly tensioned diamond chain must not be bowstring tight and can be pulled freely around the guide bar by hand easily without binding."

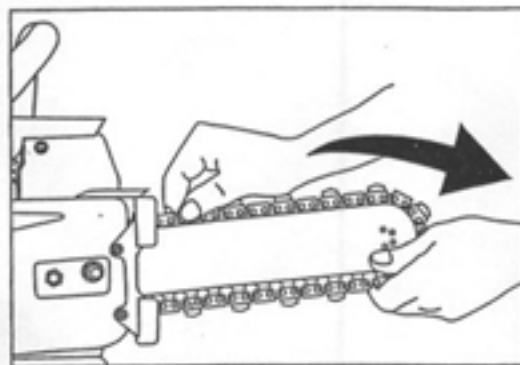

## Additional Tensioning Tips:

- 1) To reduce chain stretch and tensioning downtime, use 20 psi (1.4 bar) or greater water pressure.
- 2) Oil the chain at the end of the day to prevent rust but be careful not to over tension in this condition.
- 3) When pulling the chain around the bar by hand, be careful not to touch the bar with thumb or forefinger. The bar rails can be very sharp. Grab only the diamond segments to pull the chain.
- 4) Always pull the chain away from the Wallwalker®. The point of the Wallwalker® can also be very sharp.
- 5) Always turn the engine off before tensioning the chain.



*Division of Edge Industries, Inc.*

**Cutters Edge Offices**

P.O. Box 846  
3855 23rd Street  
Baker City, Oregon 97814  
Telephone: 541-524-9999  
Fax: 541-524-9996  
Email [info@cuttersedge.com](mailto:info@cuttersedge.com)

**East Coast Service Center**

Eastern Fire Equipment Services  
326 Pleasant View Rd.  
New Cumberland, PA 17070  
Tel: 717-412-7746  
Email: [office@efesinc.com](mailto:office@efesinc.com)

**[www.cuttersedge.com](http://www.cuttersedge.com)**