



Pressure mounts on Caterham
Why it must score a point this season

FORMULA 1 • SPORTSCARS • TOURING CARS • NASCAR • INDYCAR • RALLYING • NATIONAL RACING & MORE

AUTOSPORT

Still an F1 legend 30 years on

MAY 3 2012 • £3.40 • www.autosport.com

Villeneuve remembered

Mark Hughes on what made him the world's fastest driver



PLUS

DTM BRIT 1-2 IN NEW-LOOK OPENER

P42P4

INDYCAR POWER SCORES A HAT-TRICK

P44

BTCC SHEDDEN STARS AT THRUXTON

P36

haymarket



C\$8.99



THE

PERFORMANCE SHOW

MAY 7TH

BANK HOLIDAY MONDAY



NEW FOR 2012

"KING OF THE HILL"

DRIFT EVENT

EUROPEAN SERIES
**DRIFT
ALLSTARS**



PUBLIC TRACKTIME, CAR CLUB AREA, TRADE VILLIAGE, SHOW AND SHINE,
9 HRS OF TRACK ACTION, NEW TO OLD SKOOL, 900 BHP NASCAR LIVE
TURBO F1 LIVE, THE BTTF CAR, RACING TRUCKS, ON AIR SECTION, PITS OPEN ALL DAY



LYDDEN HILL RACE CIRCUIT

KENT, CT46ET



£15 per person



WWW.BHPPERFORMANCESHOW.COM



CONTENTS

May 3 2012 - vol 208 no 5



AUTOSPORT.COM

Up-to-the-minute news and reports from F1, WRC and more. Subscribe for must-read opinion, stats and images

IPAD EDITION

Now available to download via the Apple Newsstand



COVER IMAGE: WR12.NET
INSET: COATES, WOOD/LAT



REPORTS

- 32 WRC Argentina**
Sebastian Loeb cruises to his 70th career win for Citroen
- 36 BTCC Thruxton**
Gordon Shedden double gets Scot's title bid back on track
- 42 DTM Hockenheim**
It's a Brit one-two for Mercedes aces Paffett and Green
- 44 IndyCar Sao Paulo**
Three out of three for Penske's perfect Power
- 51 GP2 Bahrain**
Valsecchi and Dillmann share the Sakhir spoils
- 52 WTCC Slovakia Ring**
Shock! Chevrolets beaten by Tarquini's SEAT Leon
- 54 F2 Algarve**
Luciano Bacheta continues perfect start to 2012
- 56 World of Sport**
NASCAR; F3 Euro Series; Int GT Open; Grand-Am; BRC

NEWS

- 8 Pirelli's tyre gamble paying off**
Unpredictable rubber key to superb start to season
- 10 Cockpit-safety research continues**
Issues still need addressing says ex-F1 racer Alex Wurz
- 12 Caterham adamant it can progress**
British squad to relocate and recruit in a bid to improve
- 15 This week in F1**
A round-up of the post-Bahrain news
- 18 DTM insiders hail reborn tin-top series**
Thumbs up for new-look series from top names
- 20 Massive Pau entry forces qualifying split**
Separate sessions for French street-race classic
- 23 BTCC equalisation rules preclude new Hondas**
Dynamics: no more NGTC customer cars
- 24 Historic WRC events facing 2013 calendar axe**
Acropolis and New Zealand set to be dropped next year

FEATURES

- 26 Gilles Villeneuve remembered**
Mark Hughes deconstructs the myths surrounding the great French-Canadian on the 30th anniversary of his death
- 60 Formula Renault 3.5 preview**
The new car is way quicker than the old one - and the series is way cheaper than GP2. No wonder the line-up looks good

REGULARS

- 5 From the editor**
- 6 Snapshot**
- 17 Mark Hughes column**
- 62 Subscribe for a free gift**
- 88 Final drive**
Letters and latest gear
- 90 On track/on screen**
The best action in the next week
- 93 From the archive**
Gilles Villeneuve: F1 Atlantic sensation of the mid-1970s
- 94 Race of my life**
Vincenzo Sospiri, F3000 Pau GP 1993

SPORTS EXTRA

- 75 F3 aces commit to Pau Historique meeting**
Alex Lynn and Harry Tincknell need to learn classic circuit
- 76 Gamble to gamble on single-seater switch**
F1 Renault BARC switch for ex-Ginetta racer George Gamble
- 79 Meyrick to race Aston Group C car at Donington**
Historic outing for factory driver in AMR1 prototype
- 80 National reports**
Thruxton TOCA; Brands Hatch 750MC; Donington Park MSVR; Silverstone AMOC; Prescott BHC; Kirkistown 500MRCI; Snetterton BRSCC; Croft BARC

Perfect Paffett leads C-coupe superiority

Former champion Gary Paffett led home fellow Brit Justin Green for an HMI Mercedes one-two in the one-track DTM

Only this time it wasn't a surprise. Paffett, who relinquished the title to Timo Glock in 2009, was a double pole position. He made a superb start, leading the field to the first lap. Paffett's Mercedes was a dominant force, leading the field to the first lap. Paffett's Mercedes was a dominant force, leading the field to the first lap.

RESULTS

Pos	Driver	Team	Time
1	Gary Paffett	Mercedes	1:00:00
2	Justin Green	Mercedes	1:00:05
3	Timo Glock	Mercedes	1:00:10
4	Christoph Florschütz	Mercedes	1:00:15
5	Christoph Florschütz	Mercedes	1:00:20

SHINE ON YOU CRAZY DIAMOND

Gilles Villeneuve was much more than smoking tyres and three-wheeled lunacy. MARK HUGHES argues that he should be remembered as a champion in the right way

The Villeneuve legend is a complex one. He was a driver who was ahead of his time, a driver who was a pioneer. He was a driver who was a pioneer. He was a driver who was a pioneer.

NEWS SPORTS EXTRA

MARCUS PYE HUMBLE PYE

The voice of club motor racing

Gamble to Formula Renault

Designer and driver George Gamble's ambition to bring forward his son's racing career

George Gamble is a name that is well known in the world of motorsport. He is a designer and a driver. He is a designer and a driver. He is a designer and a driver.

REGULARS

Strong RGB debut for Millroy

Matthew Millroy's debut in the BTCC was a success

Gow hails single-seater talks

Chris Gow is optimistic about the future of single-seater racing

RENAULT Clio change to go competitive just ahead

Renault's new Clio is a competitive force in the BTCC

Procter battles to maiden ERC win as Doran suffers a setback

Matthew Procter's debut in the ERC was a success

REGULARS

Forget the status of the competitor, the style of Wauer's achievement staggered onlookers

Wauer's achievement in the ERC was a success



NISSAN *nismo*

NISSAN GT-R NISMO GT3
Official Partner

BUILT TO WIN.

Congratulations to *JMH Automotive* for claiming
the first outright victory with a NISSAN GT-R NISMO GT3



NISSAN *nismo*

NISSAN GT-R NISMO GT3
Customer Racing

JMH
AUTOMOTIVE

Teddington Studios, Broom Road, Teddington, Middlesex TW11 9BE, UK.
Tel: +44 (0) 20 8267 5804 Fax: +44 (0) 20 8267 5922
E-mail: autosport.editorial@haynet.com Website: www.autosport.com

EDITOR-IN-CHIEF

Andrew van de Burgt
andrew.vandeburgt@haymarket.com ext.5974

EDITOR

Charles Bradley
charles.bradley@haymarket.com ext.5889

AUTOSPORT.COM EDITOR

Simon Strang ext.5093
simon.strang@haymarket.com

GROUP F1 EDITOR

Jonathan Noble ext.5810
jonathan.noble@haymarket.com

F1 EDITOR

Edd Straw ext.5887
edd.straw@haymarket.com

FEATURES EDITOR

Kevin Turner ext.5432
kevin.turner@haymarket.com

NEWS EDITOR

Glenn Freeman ext.5309
glenn.freeman@haymarket.com

REPORTS EDITOR

Jamie O'Leary ext.5811
jamie.oleary@haymarket.com

MANAGING EDITOR

Peter Hodges ext.8617
peter.hodges@haymarket.com

US EDITOR

Mark Glendenning
mark.glendenning@haymarket.com

WEB MANAGING EDITOR

Pablo Elizalde

GRAND PRIX EDITOR

Mark Hughes
autosport.editorial@haynet.com

F1 COLUMNIST

David Coulthard

SECRETARY

Joanne Grove
joanne.grove@haymarket.com ext.5804

PHOTOGRAPHS

LAT Photographic

CORRESPONDENTS

ARGENTINA

Tony Watson

AUSTRALIA

Phil Branagan

AUSTRIA

Gerhard Kuntschik

BELGIUM

Gordon McKay

BRAZIL

Lito Cavalcanti

FINLAND

Esa Iiloinen

GERMANY

Rene de Boer

GREECE

Dimitris Papadopoulos

Tel: +44 (0) 20 8267 5820
Fax: +44 (0) 20 8267 5850
E-mail: autosport.ads@haymarket.com

COMMERCIAL MANAGER

Rachel Brock
ext: 5820
rachel.brock@haymarket.com

DISPLAY ADVERTISING

Andrew Barclay
ext: 5244
andrew.barclay@haymarket.com

Peter De Vries

ext: 5961
peter.devries@haymarket.com

Karen Reilly

ext: 5576
karen.reilly@haymarket.com

ONLINE ADVERTISING

Leanne Foley
ext: 5846
leanne.foley@haymarket.com

Chris Gowland

ext: 5281
chris.gowland@haymarket.com

Rupert Patterson-Ward

ext: 5928
rupert.patterson-ward@haymarket.com

CLASSIFIED ADVERTISING

Billy Jones
ext: 5367
billy.jones@haymarket.com

Alex Newberry

ext: 5895
alex.newberry@haymarket.com

ADVERTISING DIRECTOR

Matthew Witham

SPECIAL PROJECTS DIRECTOR

Derek Redfern

LICENSING DIRECTOR

Jim James

PRODUCTION MANAGER

Carrie McNally
ext: 5814
carrie.mcnally@haymarket.com

SENIOR DISPLAY PRODUCTION CONTROLLER

Saba Bonser
ext: 5740
saba.bonser@haymarket.com

PRODUCTION CONTROLLER

Marc Baker
ext: 5563
marc.baker@haymarket.com

ADVERTISING DIRECTOR

Giorgio Piola

NEWS GRAPHICS

Alan Eldridge

CARTOONIST

Jim Bamber

ITALY

Roberto Chincherio

JAPAN

Jiro Takahashi, Len Clarke

NEW ZEALAND

Bernard Carpenter

RUSSIA

Gregory Golyshev

SOUTH AFRICA

Richard Asher

SPAIN

Raimon Duran

SWEDEN

Tege Tornvall

USA

Jonathan Ingram, Bruce Martin, David Phillips, Diego Mejia, Robin Miller, Jeff Olson, Jeremy Shaw, UK & EIRE

David Addison, Ben Bostock, Dud Candler, Jonathan Crawford, Kerry Dunlop, Leanne Fahy, Paul Healy, Paul Jurd, Paul Lawrence, Marc Orme, Graham Read, Peter Scherer, Ian Sowman, Oliver Tinson, Ian Titchmarsh, Matt Upton, Eddie Wallace, Tim Whittington, Richard Young

ADVERTISING DIRECTOR

Matthew Witham

SPECIAL PROJECTS DIRECTOR

Derek Redfern

LICENSING DIRECTOR

Jim James

PRODUCTION MANAGER

Carrie McNally
ext: 5814
carrie.mcnally@haymarket.com

SENIOR DISPLAY PRODUCTION CONTROLLER

Saba Bonser
ext: 5740
saba.bonser@haymarket.com

PRODUCTION CONTROLLER

Marc Baker
ext: 5563
marc.baker@haymarket.com

POLE POSITION

Villeneuve: remembering an F1 enigma 30 years on



I CAN STILL REMEMBER WITH ALMOST frightening detail what I was doing when I learned that Gilles Villeneuve had been killed.

I might have only been seven at the time, but I'd already been a Formula 1 fan for almost as long as he'd been in the sport, and while I was too young to understand why exactly, I knew that he was special and his death profoundly affected me.

Thirty years later and it's safe to say that we've not seen his like since. That's not to say that drivers like Fernando Alonso or Sebastian Vettel are any less skilled, but such is the wall-to-wall coverage these days, not to mention the tell-all capability of telemetry, no-one will ever be able to recreate the mystique that continues to surround the Villeneuve legend.

But how good was he really? Mark Hughes is in no doubt, and his brilliant retrospective should help make your mind up, too. While you're at it, search for: 'Villeneuve's wild day in Argentina 1980' on YouTube and indulge yourself in a rare talent.

ANDREW VAN DE BURGT
EDITOR-IN-CHIEF

andrew.vandeburgt@haymarket.com

Find us on



AUTOSPORT
PODCAST

BAMBER'S WEEK

SUBSCRIPTIONS

UK 0844 8488817

OVERSEAS +44 (0)1795 592 974

EMAIL

autosport@servicehelpline.co.uk

US & CANADA 1-866-918-1446

US & CANADA EMAIL

haymarket@usnews.com

AUTOSPORT, ISSN number 0269946X, is published weekly by Haymarket Media Group, Teddington Studios, Broom Road, Teddington TW11 9BE, United Kingdom. The US annual subscription price is \$235. Airfreight and mailing in the USA by agent named Air Business Ltd, c/o Worldnet Shipping Inc, 156-15, 146th Avenue, 2nd Floor, Jamaica, NY 11434, USA. Periodicals postage paid at Jamaica NY 11431. Subscription records are maintained at Haymarket Media Group, Teddington Studios, Broom Road, Teddington TW11 9BE. Air Business Ltd is acting as our mailing agent.

BACK ISSUES

Tel: 0844 8488817

DIRECT MARKETING EXECUTIVE

Karen McCarthy, ext: 5658
karen.mccarthy@haymarket.com

SPECIAL EVENTS MANAGER

Laura Coppin

SYNDICATION SALES MANAGER

Roshini Sethi, +44 208 267 5396
roshini.sethi@haymarket.com

CIRCULATION TRADE ENQUIRIES

Frontline Ltd, Park House, 117 Park Road, Peterborough, Cambs, PE2 2TS. Tel: +44 (0)1773 355161. Printed in England by Wyndeham Press Ltd. Cover and centre sections printed by CSM Impact, Basingstoke. Colour origination: Colour Systems, 20-22 Pentonville Road, London N1 9HS (editorial and advertising). ISSN 0269-946X. AUTOSPORT, incorporating Autosport, is published weekly by Haymarket Consumer Media, Teddington Studios, Broom Road, Teddington, TW11 9BE, UK.

EDITORIAL DIRECTOR

Mark Payton

DESIGN DIRECTOR

Paul Harpin

STRATEGY AND PLANNING DIRECTOR

Bob McDowell

PUBLISHING DIRECTOR

Patrick Fuller

MANAGING DIRECTOR

David Proctor

CHIEF EXECUTIVE

Kevin Costello

PEFC

PEFC Certified

This product is from sustainably managed forests and controlled sources

www.pefc.co.uk

Haymarket is certified by BSI to environmental standard ISO14001

www.haymarket.com

www.haymarket.com





CERVEJA
ITAIPAVA

INDYCAR

There must be a sliproad up ahead somewhere

IndyCar ace Ryan Hunter-Reay is the only driver in this picture from Sao Paulo last weekend who isn't stuck in the Brazilian traffic – just as well if you recall his last-lap antics in the previous round at Long Beach. RHR went on to finish second, with a rather higher average speed than any of the assorted car/truck/bus drivers who passed by in blissful unawareness. Full report, p44.

Pic: Laberge/Getty



**FOR THE BEST PHOTOS ONLINE,
VISIT AUTOSPORT.COM/GALLERY**



Pirelli's F1 gamble paying off

Unpredictable tyre behaviour has led to the best start to a season since 1983. By EDD STRAW

Formula 1's most unpredictable start to the season since 1983 is a result of Pirelli running the risk of negative publicity in response to its high-degradation tyres.

During the 2010 season, one-stop strategies were the most common. But Pirelli's arrival in 2011, and the introduction of the DRS rear wing, was complemented by the second year of no mid-race refuelling and has contributed to different drivers and teams winning each of the season's first four races for the first time in almost 30 years.

Had previous tyre supplier Bridgestone continued in F1, the racing would be very different.

In China, ex-Bridgestone head of motorsport tyre development Hirohide Hamashima, now at Ferrari, admitted that the Japanese company would have been unwilling to produce such rubber had it continued. This was despite the 2010 Canadian Grand Prix, during which the Bridgestone rubber degraded rapidly to create a topsy-turvy race, producing the sort of action that the sport was calling for.

"In the case of Bridgestone, if the FIA required tyres for just 100kms, maybe they would refuse that proposal," said Hamashima.

"Bridgestone would like to show good performance and durability.

It is the most fundamental issue for tyre manufacturers."

But the sport requested high-degradation tyres as part of a raft of measures designed to deliver the overtaking that 84 per cent of fans deemed as important in the comprehensive *F1 Racing/LG* survey in 2010. Some senior figures at Pirelli were unsure about deliberately producing fragile tyres, but the firm went ahead with the risky strategy ahead of its return for 2011.

Pirelli motorsport director Paul Hembery told AUTOSPORT: "It was brave in the sense that you have got to educate the public and make people understand that this is what we were asked to do. If everyone has the same tyres, it's always going to be down to the drivers and engineers to get the best out of them."

The tyre debate flared up after the Bahrain GP when Michael Schumacher, unprompted, hit out at the fact that you must drive under the limit of the car during grands prix to make the rubber last in an interview with Sky Sports.

"I'm not happy about the situation," he told Radio 5 Live when

asked a follow-up question about his comments. "If it was just a one-off car issue, you could say it's on us to deal with it. But if it's 80 per cent of the field that has this problem, maybe the tyre supplier should think of that."

Schumacher said that he would "probably" raise this issue with Pirelli. But Hembery insists that Pirelli has "had no contact over and above normal team briefings" on the matter.

Nico Rosberg disagreed with his Mercedes team-mate. The Chinese Grand Prix winner said that he enjoyed the challenge of Pirelli's.

"No, definitely not," he said when asked by AUTOSPORT if he agreed with Schumacher. "It's a very difficult challenge, but also an interesting one to get the most out of the tyres."

McLaren driver Jenson Button took a similar stance, admitting that his team has yet to get on top of the rubber and refusing to use the tyres as an excuse for the British outfit's lack of pace in Bahrain.

"Other people are making them work so we've just got to deal with it," said Button. "I don't think we



'Good' tyres meant less drama in races



PIRELLI'S 2012 HEROES AND ZEROES

HEROES

PAUL DI RESTA, BAHRAIN

The Force India driver was the only man in the field to complete a two-stop strategy. He briefly led after most of the field had made their first stops and carefully measured his pace in the final two stints, hanging on to sixth place despite his tyres going off at the end of the final lap.



SEBASTIAN VETTEL, BAHRAIN

Managed to extend the life of a used set of softs during his third stint to pit at the same time as Kimi Raikkonen, who was running on a fresh set of mediums. Turned fast laps at the end of his final stint to edge away and win without killing his tyres.



SERGIO PEREZ, AUSTRALIA

Relegated to the back of the grid by a gearbox penalty, the Mexican opted for a one-stop strategy. Climbed as high as second before making his only stop and could have finished sixth but for losing a few places in the last-lap confusion after Pastor Maldonado crashed his Williams.



ZEROES

KIMI RAIKKONEN, CHINA

Stopped for the second time on lap 28 and attempted to go the distance. Was running second with eight laps to go when his tyres 'fell off a cliff'. In two laps, he was down to 12th. Lotus team-mate Romain Grosjean stopped four laps later but his rubber held on and he finished sixth.



FERNANDO ALONSO, CHINA

Opted for a three-stop strategy, but didn't have the raw pace to make it work. Slipped to ninth in the final stint behind both Williams and the Lotus of Romain Grosjean, all of which made a two-stop strategy work.



JENSON BUTTON, MALAYSIA

After driving into Narain Karthikeyan, Button rejoined on intermediate rubber but because of traffic couldn't maintain tyre temperature. He spent the rest of the race buried in the midfield and failed to score.



AUTOSPORT SAYS...

EDD STRAW F1 EDITOR

edd.straw
@haymarket.com



When Ferenc Szisz won what is recognised as the first grand prix at Le Mans in 1906, one of the contributing factors was Michelin's detachable rims. This technology allowed a tyre change to be completed in around a quarter of the time of those who had fixed rims. Then, as now, tyres played a key role.

Grand Prix racing has never been as simple as drivers going as fast as they can. It's a question of going as fast as you can in the circumstances, whether those are framed by track conditions, boost pressure, fuel consumption, tyre life or whatever.

The current formula, despite the contrivance of DRS that is a necessary evil given that more overtaking is crucial to the popularity of the sport, is far more gripping than races in which in- and out-laps are key. The assumption that just because drivers aren't having to exploit 100 per cent of their car's ultimate potential at every moment of the race does not mean that they are taking it easy and grossly oversimplifies the grand prix racer's art.

The Pirelli rubber isn't perfect. Perhaps a more gradual drop-off would be preferable, but combined with the ban on refuelling in 2010, it has made F1 a more multi-faceted driver challenge than it was a decade ago. After all, the fastest drivers are still fastest, it's just that they need to be more than just quick to prevail now.

Tyres: one of many variables in GP racing



understand them. Last year's tyres had high degradation, but we understood them. This year, I don't really know what to make of the tyres. But that's no excuse because other people are doing a good job."

Pirelli insists that, should it be asked to, it can produce high-performance, low-degradation tyres of the type Bridgestone used to supply. But Hembery stressed that this would harm the racing.

"What do people want?" he said. "You've got to be careful what you wish for. Pirelli will do what we are asked to. If they want something different, and we haven't had a single request to make changes in 18 months, we can do. For some people, it's the most exciting start to F1 in many years. For every complaint, there are many people enjoying it."



P17
MARK HUGHES ON THE TYRE ROW

BIG NUMBER

15

Number of passes in the 2009 Bahrain GP, the most recent race on the 'short' circuit used this year, compared with 73 this year.

F1 cockpit safety changes 'inevitable'

Former grand prix driver Alex Wurz is behind the continued research into driver-cockpit protection in single-seaters

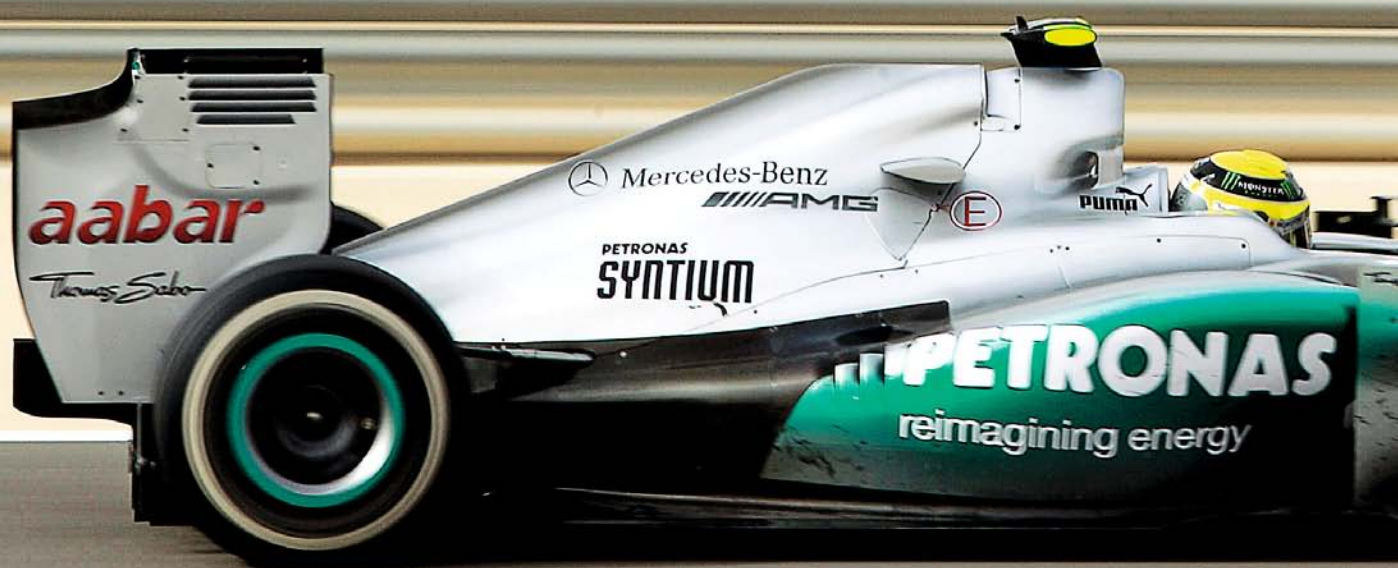

Formula 1 must incorporate additional cockpit protection in the future, according to former grand prix driver Alex Wurz.

The Austrian, a member of the FIA Institute's Open Cockpit Research Group, believes that F1 must continue to take driver head protection "extremely seriously". Speaking in the wake of the FIA Institute's latest test, which used a forward roll-hoop structure to deflect a flying wheel (see sidebar), Wurz urged the sport to consider

such technology. As well as a forward roll hoop, enclosed canopies and deflector screens have also been proposed.

"Yes, it is inevitable," Wurz told AUTOSPORT. "You have named three possibilities and there are many more. Initially, we must continue to test and research and once we know enough and are sure it's a safety improvement, F1 shall improve it."

The FIA Institute supplies data from its tests to F1's technical

"We must continue to test and research until we are sure it's an improvement"

Alex Wurz

working group. Last year, it conducted a similar test using a jet fighter canopy (AUTOSPORT, July 14). Wurz insists that safety must be the driving force in F1 deciding whether to take this route despite some critics citing tradition as a

reason not to make changes.

"Well, traditionally this sport had many fatalities," said Wurz. "I get quite frustrated about such categorical comments. Anyone fixed to tradition, would you please move to the museum and wear a leather hat, goggles and watch front-engined aluminium machines."

"The drivers didn't say that we dislike extra safety precautions. Some said they didn't like the design of the canopy or roll hoop, but we have applauded [technical

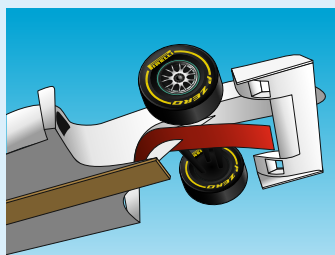

Flap would act as a stabiliser

Airborne accident prevention also under review

A moveable wing section mounted below the nose could provide an answer to the perennial problem of racing cars taking off, according to circuit designer Alan Wilson.

He believes that the system he has devised would have a benefit when a car becomes airborne after riding over the back of another. His idea (red section in image) calls for a

moulded panel or flap, running from the driver's seat to the front bulkhead, which would be activated by a hydraulic ram or rams. This, in turn, would be triggered by sensors that recognise the change in pressure under the car resulting from a nose-up situation. When lowered, the flap would act like a giant front wing, therefore bringing the car back down.

Wilson suggests that this should be used in conjunction with a system that modulates engine power. While not an aerodynamicist, Wilson believes the technology is already out there, pointing to NASCAR roof flaps, which help keep the car on the track when it spins sideways. He has sent his proposals to the FIA and the IndyCar Series.

How an F1 cockpit canopy may look



EXPERT VIEW

GARY ANDERSON
TECHNICAL CONSULTANT



The forward roll hoop is a strange-looking solution to the problem of driver head protection. It seems to be a halfway house. Many are against the idea of a canopy, but if you really want to eliminate this threat, that is the best solution.

The hoop would certainly work in the case of a loose wheel, but given that wheel tethers are mandatory and their strength has been increased, this should be something that we see less, even if it can't be eliminated entirely. But the hoop is unlikely to help in the case of the spring that hit Felipe Massa. A canopy would.

To improve safety, it's vital that it's done properly. A well-conceived, well-engineered canopy could be brought in somewhere down the line, say 2016, because it's essential that these things aren't rushed. It would be almost invisible and although many won't like it, it's worth remembering that moves like seat belts and HANS devices faced resistance at first.



Artist's impression of front-facing hoop

advisor] Andy Mellor and the FIA Institute for their work. The Grand Prix Drivers' Association has asked me to keep following progress.

"Each driver has their opinion, but these tests are about the wider picture. It's about researching the principles."

There have also been question marks about driver extraction should additional structures be incorporated around the cockpit. Some have questioned whether a driver could become trapped in the cockpit or whether screen misting might be a problem with a canopy. But these are fears that Wurz, who races a closed prototype sportscar for Toyota, doesn't believe are so straightforward.

"I race closed prototypes and yes, there is an argument [about extraction]," said Wurz. "But despite the slower extraction potential, I feel safer with a proper carbon roof. And with a smart design, maybe the extraction might not be any slower.

"Having witnessed Marc Gene's flip at Le Mans [in the pre-race test

in 2008] when he crashed roof first into a concrete wall, I know that if he had been in an open car, I would have lost a good friend.

"I also get quite worked up about arguments that a canopy would mist up. A misty windscreen? You're talking about a VW Beetle in the 1970s. There would be implications, but smart people will solve them."

Wurz paid tribute to the role that the FIA Institute plays. It was set up by the FIA in 2004 as an independent organisation focusing on safety. Its role in F1 is purely advisory, but Wurz believes that its contribution is crucial.

"It's fundamental for the sport that we have an organisation like the Institute," said Wurz. "Eighteen years ago, we had the tragic loss of Roland Ratzenberger and Ayrton Senna at Imola. We shall never forget the massive improvements achieved since then, but if we stop researching, we might lose out. Testing of roll hoops or canopies makes sense if we remember what happened in the past."



Roll hoop test gave crucial data

ROLL HOOP TEST EXPLAINED

The FIA Institute's test of the forward roll hoop was a successful proof of concept.

A 20kg wheel and tyre was fired at the roll hoop using a compressed nitrogen cannon, which was set 100mm above the driver's head, represented by a cutaway helmet placed on the ground. The wheel was deflected

over the helmet and the tyre was punctured, reducing the danger of bouncing.

It is part of a raft of tests conducted by the FIA Institute to gather data and analyse improvements to driver safety, details of which are passed on to the F1 technical working group.

Caterham certain it will recover

The team we used to call Lotus has fallen even below Marussia in this year's constructors' rankings. But it's relocating, and is on a recruitment drive



Smith with Gascoyne (l) and team chief Fernandes

Caterham technical director Mark Smith has no doubt that his team will be able to overhaul Marussia to reclaim its place in the top 10 of the constructors' championship after a "rocky" start to the season.

Caterham Group chief technical officer Mike Gascoyne had set the target "to score points and race with the bottom half of the grid", and "to be picking off people regularly and getting into Q2".

Although Heikki Kovalainen reached Q2 last time out at the Bahrain Grand Prix, the Caterham C'T01 is not significantly closer to the midfield pack than the Lotus T128 the team ran last year was at the same stage last season (see graph, top right). The deficit to the midfield has almost doubled since the end of last year, and Marussia leads Caterham in the championship thanks to Timo Glock's 14th place in the Australian Grand Prix.

"I'm not nervous about it [the fight for 10th place]," Smith told AUTOSPORT. "I know what is coming to help, whether it be personnel or tools, so we're definitely going to move forward. We need to deliver and I'll be disappointed if we don't score a point or two."

Caterham, which this year is using Red Bull KERS technology for the first time, has legitimate claims to be a team that is still in its infancy – this is only the third year for the former Team Lotus.

In August, the race team will move to its new base in Leafield, while this month ex-McLaren man John Iley joins as performance director, a role in which he is expected to have a big influence.

Smith, who has day-to-day responsibility for the technical side of the F1 team but reports to Gascoyne, pins the deficit to the midfield pack largely on the need to make up ground aerodynamically. An upgrade package introduced for last month's Chinese Grand Prix did not produce the expected benefits, but in Bahrain the team was happier with its performance.

"We have fundamentally got a good car and we made a lot of progress from China to Bahrain," said Smith. "It's about us going as fast as we can within the world of aero. We are planning to increase our time in the windtunnel, and the other area is that we have more guys doing aerodynamic analysis and coming up with aero projects."

"One of the other areas that we need to get our head around is the CFD. We're looking specifically at upgrading the facility in terms of personnel as part of the Leafield

"We need to get our head around CFD. We're looking at upgrading in personnel"

Caterham tech chief Mark Smith

installation. We won't have that by the end of August, but we hope to start working with that by the end of the year. I can't put a number on it, but it will be a significant upgrade CFD-wise, although it will take a little while to come through."

Caterham also hopes to harness the exhaust effect to create downforce. This is an area where the team struggled last year, and pre-season Gascoyne highlighted the *de facto* ban on exhaust-blown diffusers as an advantage for his team.

But rivals are still finding performance in this area, where Iley is expected to have an influence.

At this week's Mugello test a modified floor was tried with a view to achieving the effect.

"There are teams who have been able to capitalise on the packaging of

the exhaust plume to give beneficial aerodynamics," said Smith. "There are a couple of cars that do that very well, but you look at other cars and they have a fairly conventional tailpipe."

"John is going to take a broader role than just aerodynamics. Because of his wealth of experience, I'm confident that he will be able to contribute to the exhaust structure quickly. But it takes a while and it will be the other side of the August shutdown before we're really able to see the benefit of that."

Although it would be disastrous in sporting terms for Caterham to slip to 11th in the end-of-year rankings, it would not cost the team its slice of the historical money distributed by the sport. To qualify for this, a team needs only to finish in the top 10 twice over a three-year period.



Caterham needs to master exhaust uses

Glock's Oz result puts Marussia in 10th place



CLOSING ON THE MIDFIELD?

This graph represents the gap between the best-performing driver for each of the new 2010 teams and the last midfield team's leading driver, from the start of the 2010 season to Bahrain 2012. The figures, shown as a percentage, are based on average raw pace calculated in blocks of four races (save for the end-of-season block, which contains only three races).

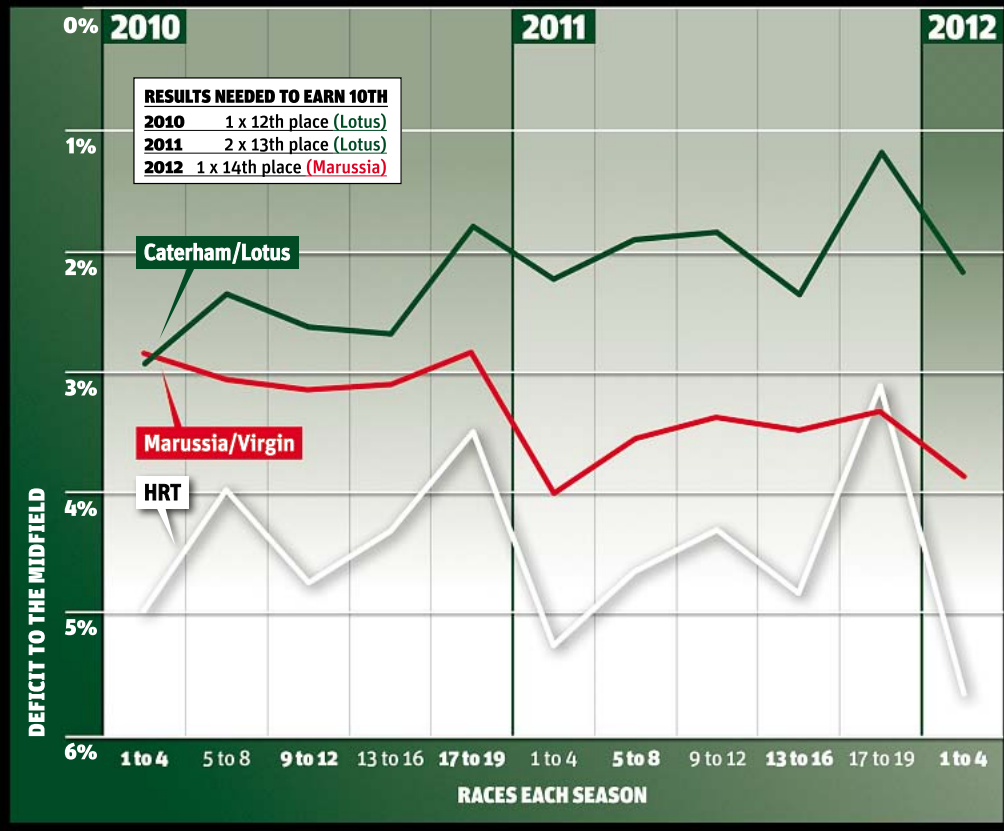

60 SECONDS WITH

VITALY PETROV

Caterham



Are you happy with your progress so far?

In the races I've been happy with what I did. The car was well-balanced and I could be quicker than my team-mate. I'm still losing performance in qualifying. We aren't getting the maximum from the tyre, which is where I'm trying to improve.

What's your impression of the Caterham team?

Everything is OK. The relationship inside the team is very good. There have been some good upgrades from all the teams. What we have shown so far are our maximum results.

Things weren't always easy when you were with Renault. Is this a better environment for you?

It's a little bit easier because we are not fighting with 20 cars, we're fighting with just some of them. At the moment, the strategy is easy.

The Chinese GP updates started to work in Bahrain. Does this give the team a good platform to build on this year?

It's difficult because the other teams are always improving. It looks like the upgrades have worked, and there's a new floor for the Mugello test and then Barcelona, which should have a good effect.

When do you expect to join the midfield?

At the end of the year. More or less by the end-of-season flyaways. If we can beat someone in front of us with our normal speed and the same conditions, we will have done a good job.

Are you looking at making sure that this team develops in the long-term now?

This year, I'm trying to get the maximum from myself. The target is to get the team into good shape for the end of the year and next year.

The race pace has been good. Do you feel you have been able to show your potential more consistently than before, even though it's a lower-profile team?

I have tried to work on doing that. Race consistency has been very good and I was always able to push hard.



Vitaly Petrov was talking to AUTOSPORT F1 editor Edd Straw



Petrov is sure team is on the up





2012 FORMULA 1 SINGTEL SINGAPORE GRAND PRIX

THE ULTIMATE STREET RACE UNDER THE STARS

SINGAPORE MARINA BAY STREET CIRCUIT 21 • 22 • 23 SEPT 2012



JAY CHOU



MAROON 5



KATY PERRY



BANANARAMA



PRETENDERS



THE PROCLAIMERS

TICKETS NOW ON SALE

3 DAY PASSES, SINGLE-DAY WALKABOUT TICKETS, GROUP BOOKINGS AND COMBINATION PACKAGES AVAILABLE.

ENJOY THRILLING RACE ACTION & WORLD-CLASS ENTERTAINMENT WITH JUST ONE TICKET

ONLINE BOOKING:

www.singaporegp.sg

PHONE BOOKING:

+65 6738 6738

AVAILABLE AT ALL
AUTHORISED
TICKETING AGENTS



Scan this code
for event details

TITLE SPONSOR



SUPPORTED BY



Artiste line-up is subject to change.

The F1 FORMULA 1 logo, F1, FORMULA 1, FIA FORMULA ONE WORLD CHAMPIONSHIP, SINGAPORE GRAND PRIX and related logos are trademarks of Formula One Licensing BV, a Formula One group company. All rights reserved.

THIS WEEK IN F1



TEAMS BACK ROOKIE SILVERSTONE TEST

The majority of F1 teams are set to conduct their young-driver running at Silverstone after the British Grand Prix. Only Red Bull and sister team Scuderia Toro Rosso have chosen to test in Abu Dhabi, where the test has been run for the past two years. Details of the tests have yet to be finalised.



FOLLOW MUGELLO TESTING COVERAGE ON
AUTOSPORT.COM

MUGELLO TEST GETS UNDERWAY

Formula 1's first proper in-season test since 2008 kicked off on Tuesday, with Ferrari trawling the first of a raft of updates as it ran a revised exhaust exit set-up and bodywork (circled) as AUTOSPORT closed for press.

Chelsea joins Sauber



Premier League club Chelsea has completed a sponsorship agreement with the Sauber team. The Swiss outfit will run Chelsea FC decals on its engine cover in a deal that starts on the Spanish Grand Prix weekend, during which Chelsea will contest the Champions League final in Munich.

Red Bull demo plan

A 2010 Red Bull RB6 will be demoed at each World Series by Renault event this year. Scuderia Toro Rosso driver Jean-Eric Vergne will drive in the opening round at Motorland Aragon in May, with Daniel Ricciardo and Sebastien Buemi slated to drive later in the year. In previous years, Renault machinery has been used for the F1 demo runs.



British GP capacity up

Crowd capacity for the British Grand Prix has increased by over 3500, with new grandstands at Luffield and on the National Straight added to satisfy demand. Tickets for the race are still available via www.silverstone.co.uk

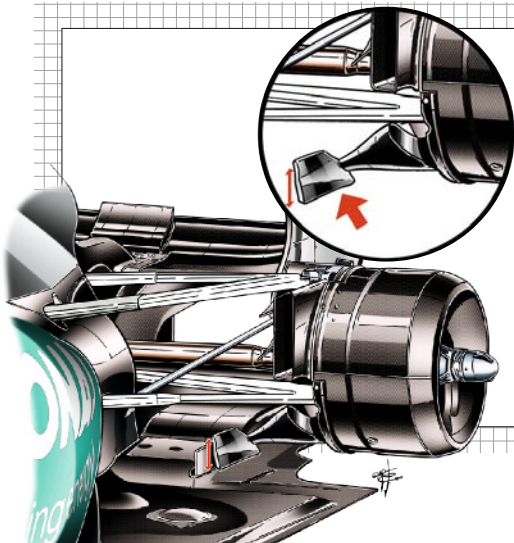

MERCEDES BRAKE DUCT

→ Mercedes' rear brake duct is a complex component that incorporates additional aerodynamically-shaped pieces below and in front of it (as can be seen more clearly in the inset drawing).

GARY ANDERSON: The only part of this assembly required for cooling the brakes is the inlet in front of the wheel. These wing sections inside of that will give some downforce independently but they will also

reduce the amount of airflow that spills under the sides of the diffuser that would otherwise compromise its performance – particularly at high ride heights when the pressure beneath the diffuser would reduce. The vertical section mounted at the lower extremity of the duct (red arrow in main drawing) works in conjunction with the vane alongside (big arrow in inset drawing) so that when the suspension moves upwards this acts as a skirt to avoid the spillage to the diffuser. Last year this assembly worked in conjunction with the exhaust gases but with this year's regulations these devices have become ever-more complicated and are now further away from a simple brake duct than ever.

DTM

BRANDS HATCH FRI 18 - SUN 20 MAY

THE WORLD'S FASTEST
TOURING CARS

ADVANCE TICKET PRICES*

SUNDAY (ONLINE)	£29
WEEKEND (ONLINE)	£35
GRANDSTAND SEAT	£15
CAMPING (ONLINE)	£16
CHILDREN 12 & UNDER GO FREE	



0843 453 9000
BRANDSHATCH.CO.UK



* Advance tickets available until midday Wed 16 May. Postage fee applies.



WORLDS **LIGHTEST** AND **STRONGEST** HELMET!!



Stilo tops the podium in Slovakia, congratulations to Stilo wearer's **ROB HUFF** winner of **WTCC Round 8** and **GABRIELE TARQUINI** winner of **WTCC Round 7**

- ✓ **ST4 8860 Zero** - The worlds lightest 8860 helmet
- ✓ **Zero Range** - Consists of three race versions
- ✓ **FN** - New shape for 2012 for Formula cars
- ✓ **Wide** - Designed for saloon cars with electronics, drinks system and wide aperture
- ✓ **Formula** - For open top cars with electronics and drinks system
- ✓ **Incredibly Light** - Weighing 1.19kg to 1.25kg depending on model
- ✓ **Incredibly Strong** - Easily passing the FIA 8860-10 testing
- ✓ **Call** - For more in depth information about this remarkable helmet



Nicky Grist Motorsports Limited
Unit 5B
Westwood Industrial Estate
Pontrilas
Herefordshire
HR2 0EL



e: info@nickygrist.com | t: +44 (0)1981 241040 | w: www.nickygrist.com



MARK HUGHES

GRAND PRIX EDITOR

Michael Schumacher recently took the lid off an uncomfortable truth for F1: Pirelli's tyres may produce close racing, but it's all artificial. There's a 'real' way to produce the same effect, and we had it before...

Many fans seem to have been taken aback by Michael Schumacher's recent assertion that the Pirelli tyres have turned grands prix into nothing more than 'driving to a delta time', that no longer can you race flat-out, that all everyone is doing is the equivalent of cruising around behind a faster-than-usual safety car. At some tracks more than others, everyone is driving within a percentage time of flat-out in order to give the most efficient trade-off of speed and stint length – and that's driven by tyres that degrade in an almost linear way the harder you push them.

It's something we pointed out in this column as long ago as the winter of 2010-11, when Barcelona testing had revealed the initial

which was underscored by drivers driving 2s or more off the pace in the early stages in order to be able to do a competitive stint length.

This was the first time in F1's history that it had deliberately introduced something that prevented drivers from going flat-out. We'd had in the past technology limitations, but this was something different: an artificial limit on how hard the drivers could push.

Is that good or bad? In combination with DRS and KERS it's produced a lot of action that has definitely livened up the show, the very thing Pirelli was tasked with. But it's as if many fans have not wanted to know about the sleight of hand that has made it; namely tyres that impose a blanket limit on cars and drivers, keeping the pack much closer-matched.

Wasn't it always the case that a tyre would degrade more the harder you pushed it? The effects were mitigated in the past by the track rubbering in. As the tyres degraded they were also laying down a line of rubber that was increasing the grip of the track. The Pirellis don't do that. Their grip is much more mechanical (the clawing of the tyre against the surface irregularities) than chemical (the bonding of the surfaces of tyre and track at a molecular level). So the harder you push them the quicker they degrade (and usually that is heat degradation rather than wear).

The fastest car/driver combination will still be the fastest, and the slowest the slowest, but if you try to take too much of the available grip too early you'll be consigned to a drastically short stint length, meaning you drop

into traffic, your later stints will be too long and you're a sitting duck. A car with too little downforce can still abuse these tyres by excessive sliding, but generally on these tyres the faster car will take more out of the tyre, simply because it's going faster and there's little chemical grip to ease the stress on the structure of the tyre.

So last year we saw a vastly-superior car – the Red Bull RB7 – winning by only small margins as the team and Sebastian Vettel took only as much from the tyres as they dared. The car's speed allowed Vettel to qualify on pole, and thereafter he was forced to carefully monitor the tyres' grip. On more traditional tyres, what we'd probably have seen was Red Bull winning by half a lap or more – and many would have been up in arms at how dull the races were.

But it would have been real. As a purist I'd prefer to watch an unpalatable truth than a Disneyfied fantasy. But that would drive the audience away – unless the cars genuinely were closely matched (which they actually appear to be so far this year).

The best combination of swings in the competitive order with full-fat, flat-out genuine racing was in the tyre-war era. Many didn't like how a tyre could be the dominant factor in the result – but that's at the root of unease about the current situation too. Tyres will always be dominant. Back then it was about pushing the limits of technology to go faster, with the driver unleashed to maximise what he was given by pushing to the max. Now the technology is being used to artificially keep the fastest within reach of the less fast. ❧

PIC: GILHAM/GETTY

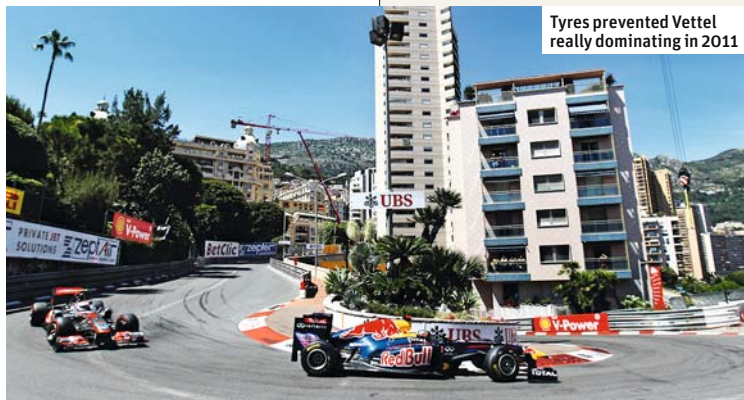

picture of Pirelli-era F1. It was followed up in the early race reports from last year, when we suggested amid all the excitement of the multiple passing that we should understand that actually it was just a facsimile of racing, something that looked like great racing to the untrained eye, but

“The best swings came in the full-fat tyre-war era”



New-look DTM featured 22 cars from three marques

DTM

New rules make DTM great again

Drivers and team bosses say regulations will make for best racing in years following opening round

Leading figures from the DTM believe this year's championship battle will be the closest for years, following the debut of the series' new-for-2012 technical rules package at Hockenheim last weekend.

Just 1.1 seconds separated the top 19 cars during the opening part of qualifying, with a lap more than 0.849s off the pace ensuring that a driver would progress no further into the session. Cars from Audi, Mercedes and BMW qualified in the top three, further indicating how close the battle has become over the winter.

Mercedes motorsport vice-president Norbert Haug praised his rival manufacturers, German motorsport federation the DMSB, and DTM organiser the ITR for working closely together to create a set of cost- and safety-conscious regulations that would not allow anyone to steal a decisive advantage.

"There were three manufacturers in the top three in qualifying, and nobody could have dreamed of this," he said. "It's not a fixed result either. After a very tough

Priaulx took a fine sixth for BMW at Hockenheim



competition it's a great result for everybody involved.

"It's important to thank the DMSB and the ITR and all our guys who have worked so hard. We could have had a situation where one manufacturer was half a second ahead, but it has not happened like that. This is a great yardstick and I think we'll have a great season."

Following Schnitzer driver Dirk Werner's unexpected third place on the grid for BMW and Andy

Priaulx's sixth place in the race for the RBM squad, the marque's motorsport director Jens Marquardt said he was satisfied that the regulations had allowed his cars to enter on a more level playing field than previously expected.

"Nobody really knew where the balance of power would lie this weekend," he said. "But it's great news for the fans that all the cars seem to be on a similar level. I don't know if what we

saw at Hockenheim will stay that way for the next races, but it's a good start."

The race also featured far more on-track passing moves than the one that brought the 2011 season - and the old set of regulations - to a close at the same circuit last October, with the Spitzkehre in particular featuring significantly far more overtaking than previously.

Phoenix Audi driver Miguel Molina said that the closeness of the competition was likely to increase the number of on-track battles, following a bruising race in the midfield.

"There is more of a physical fight with the cars now," he said. "You cannot be tactical, you have to make an opportunity to pass a car on the circuit. I think this will be very exciting for the season because all the cars are so close."



P42
DTM
REPORT

LE MANS

DeltaWing Le Mans finish 'unlikely'

THE CHANCES OF THE RADICAL

Nissan DeltaWing finishing the Le Mans 24 Hours next month are small, according to leading figures involved in the project.

DeltaWing creator Ben Bowlby and Nissan Europe general manager Darren Cox have both played down the chances of the car taking the chequered flag.

Bowlby said: "If we get to the finish, I will be an emotional wreck, but I am not expecting it. The car today is not a 24-hour car.

"It is extremely difficult to have any level of certainty of finishing the race. Every component was new on March 1, and if you started claiming in those circumstances that you will finish Le Mans, everyone will rightly call you nuts."

Cox, who is the architect of the Japanese manufacturer's involvement in the project added: "The chances are we are not going to make the finish. Everyone perceives



Michael Krumm had a light crash at Snetterton

DeltaWing as this wonder car, but the reality is that from the first test to Le Mans is 101 days. This is a genuine test day for innovation."

Bowlby and Cox were present during the DeltaWing's second test in the UK at Snetterton last week, where new driver Satoshi Motoyama had his first test. The car has now completed approximately 650 miles

over four days at Button Willow, five at Sebring and three at Snetterton.

Bowlby said he wasn't unduly concerned about the lack of miles.

"We would have hoped to have done more," he said. "When we find a problem we are having to re-design and re-manufacture. You can't do that with a click of your fingers."

AUTOSPORT SAYS...

JAMIE O'LEARY
REPORTS EDITOR

jamie.oleary
@haymarket.com



What a way to kick off a new era for the DTM. Closer-than-ever competition in practice and qualifying, three manufacturers in the top three places on the grid, and a barnstorming race that was easily the best since I began covering the championship last year. It culminated in an intense wheel-to-wheel scrap for the lead between Jamie Green and Gary Paffett, involving the pair running side-by-side and inches apart for a third of a lap after winner Paffett's first pitstop.

Pre-weekend the buzz surrounded BMW, back in the DTM after 20 years away, and the Munich marque didn't disappoint with Dirk Werner a shock third on the grid and Britain's Andy Priaulx a brilliant sixth in the race – only 0.6s behind the second-best Audi.

Best of all though

was confirmation that the all-new technical rules, which were supposed to promote overtaking and close racing by means of 57 common parts and a removal of complex and expensive aerodynamic devices, have worked a treat. Overtaking was far more abundant than at the season-ending race of 2011, and the 158,000 fans that turned up to watch over the three days will surely come back for more in October.

Lausitz, which hosts the series this weekend, is a different circuit altogether and I'm not expecting another display of awesome racing, but the tight competition will surely remain. I can't wait.

BMW's return drew the crowds



WORLD ENDURANCE CHAMPIONSHIP

Liuzzi in frame for Lotus sportscar seat

FORMER GRAND PRIX DRIVER

Vitantonio Liuzzi is in the frame to make his international sportscar debut at this weekend's Spa 6 Hours.

The 31-year-old Italian, who has been out of a drive since parting company with the HRT Formula 1 squad at the end of last season, is under consideration for a seat with the Lotus LMP2 team at the second round of the FIA World Endurance Championship. He is understood to be one of eight drivers vying for six seats in the German-based team's two Lola B12/80s, which run with Lotus-

badged Judd/BMW engines.

The deal appears to hinge on Luca Moro, who raced the solo Lotus LMP2 at the Sebring WEC opener in March, being fit. The Dutchman has sustained a knee injury, which could preclude him and his driver coach, Renger van der Zande, taking part at Spa.

Liuzzi has strong links with the Lotus P2 team. HRT was last year managed by Colin Kolles, whose father Romulus is team principal of the sportscar squad.

No comment was available from either Liuzzi or the team.



Aufrecht: Talks continuing

DTM

DTM continues talks with USA and Japan

TALKS TO EXPAND THE DTM INTO JAPAN

and the USA are continuing, contrary to reports last month that conversations with both the Super GT and Grand-Am championships had come to a halt.

Delegations from both championships were present at last weekend's Hockenheim season-opener to pick up discussions with series organiser the ITR about adopting common technical rules in the near future.

ITR chairman Hans-Werner Aufrecht told AUTOSPORT: "The talks are continuing. The Japanese and the Americans were here this weekend."

Mercedes motorsport vice-president Norbert Haug, who is an advisory board member of the ITR, added: "It's very normal and obvious that this series creates interest. Yes there are talks going on, but there have been no decisions at all."



Lotus fields P2-class Lola in WEC

PICS: XPB, EBREY/LAT, GARY PARRAVANI/XYNAMATIC.COM

BIG NUMBER

71,000

Number of fans that attended last weekend's DTM opener on race day. The three-day figure was 158,000



Guesting Grosjean won last time British F3 visited Pau

EUROPEAN/BRITISH F3

Big Pau entry for 'unified' F3

French street race attracts so many cars that qualifying will be run in two groups. By MARCUS SIMMONS

The Pau Grand Prix Formula 3 event has attracted a 25-car entry — enough for the field to be split into two qualifying groups.

The French street-circuit race was originally scheduled as a round of this year's British F3 International Series, but was added to the calendar for the new FIA European F3 Championship when that was announced at the eleventh hour (AUTOSPORT, March 15).

As a result, 11 competitors from the Euro Series will join the 14 regular British F3 drivers for the May 11-13 event. Only Carlin's Will Buller (who is on GP3 duty at Barcelona), URD

Rennsport driver Lucas Wolf and GU Racing's young British racer Philip Ellis are missing from the Euro field.

British F3 series manager Lisa Crampton said: "Pau is a great way for the drivers to learn a street track before they go to Macau, or move to GP2 or Formula 1.

"Being on the FIA calendar has helped. We expected about seven Euro Series runners, so 11 is great. We're very grateful for their support. And just as our guys are happy going to race the Euro Series Hankook tyres, they're happy to come and compete on our Coopers. This is very good for the future of F3."

Talking of the qualifying split, which will mean a 15-minute session for each group, leading team boss Trevor Carlin said: "As long as they split the groups in a sensible fashion this makes perfect sense. It's a great idea — very logical."

European Championship points leader Daniel Juncadella arguably starts as favourite after finishing third at Pau last year, when it was a round of the FIA International F3 Trophy.

"It's the race I've been most looking forward to," said the 20-year-old Spaniard.

"Last year Carlos Munoz was not quick everywhere, but he was second on the grid at Pau because he'd had some previous experience there. So I think that I have a big advantage because I raced there last year.

"It gave me a lot of preparation for Macau [which Juncadella won] and I like that you can push for the limit because the sidewalks are between the track and the barrier. It's not like at Macau where you have to crash to find where the limit is."

Euro F3 leader Juncadella was third at Pau in 2011



PAU GP ENTRY LIST

CARLIN
Carlos Sainz Jr, Jazeman Jaafar, Jack Harvey, Harry Tincknell, Pietro Fantin

FORTEC MOTORSPORT
Felix Serralles, Pipo Derani, Alex Lynn, Hannes van Asseldonk

T-SPORT
Nick McBride, Spike Goddard

DOUBLE R RACING
Fahmi Ilyas, Geoff Uhrhane, Duvashen Padayachee

PREMA POWERTEAM
Daniel Juncadella, Sven Muller, Raffaele Marciello, Michael Lewis

MUCKE MOTORSPORT
Felix Rosenqvist, Pascal Wehrlein

MA-CON MOTORSPORT
Tom Blomqvist, Emil Bernstorff

JO ZELLER RACING
Sandro Zeller, Andrea Roda

ANGOLA RACING TEAM
Luis Sa Silva

➔ P57 EURO F3 HOCKENHEIM

INDYCAR

Alesi's Indy deal in doubt

JEAN ALESI'S INDIANAPOLIS 500 DEBUT has been thrown into doubt by Newman/Haas withdrawing its entry from the race.

The ex-Formula 1 race winner announced last month that a deal to race for Newman/Haas through his role as a Lotus ambassador had been "signed".

But sources suggested to AUTOSPORT at the Long Beach IndyCar event a week later that nothing had been finalised.

When the entry list for the race was published, Newman/Haas had one car confirmed but no driver listed for it.

It has since emerged that the Champ Car title-winning team has withdrawn its entry, with general manager Brian Lisles confirming to the *Associated Press* last week that it had "simply ran out of time".

"We had every intention of being there," he added. "We withdrew when it



Alesi's Indy dream seems to be over

became clear we couldn't do it properly."

Lisles said the withdrawal was not down to one particular area of the deal falling over, claiming it was "everything" when asked if the problem was with driver, sponsor or engine.

The loss of the Newman/Haas entry also leaves the Indy 500 at risk of not attracting a full grid of 33 cars. There are now just 33 on the entry list, but two

have yet to announce drivers and Michael Shank Racing does not have an engine deal for its planned attack with British racer Jay Howard.

Lotus was unavailable for comment on the status of Alesi's Indy 500 plans when contacted by AUTOSPORT.

➔ P44 INDYCAR SAO PAULO

IN BRIEF

Barnes was fined



PANTHER BOSS FINED

IndyCar has fined Panther Racing boss John Barnes \$25,000 and placed him on probation following remarks made on *Twitter* that it deemed to be damaging to the sport. Barnes was critical of the way the series handled the turbo-parity issue.

LOTUS SPLITS WITH TEAMS

Lotus has reduced its IndyCar outlay from five cars to three after splitting with Dreyer & Reinbold Racing and Bryan Herta Autosport. D&R is tipped to switch to Chevrolet power ahead of the Indy 500, while BHA is set to join the Honda ranks.

TINCKNELL NOT AT HOCKENHEIM

Carlin driver Harry Tincknell missed the F3 Euro Series opener at Hockenheim due to a clashing personal commitment. Team boss Trevor Carlin said he could do the Brands Hatch or Nurburgring rounds instead.

DELETRAZ SET FOR SPA DRIVE

Jean-Denis Deletraz is on course to make his race return after a year away in the second Gulf Racing Lola-Nissan B12/80 at the Spa World Endurance Championship round. The Swiss non-started at Sebring.

TOYOTA HYBRID BACK ON TRACK

Toyota's sportscar squad has hit its target of returning to the track in the week of the Spa WEC round, following the Paul Ricard crash that seriously damaged one TSO30 HYBRID. The second car is due to begin testing on Friday at Magny-Cours.

PANCIATICI JOINS SIGNATECH

Former GP2 and Superleague driver Nelson Panciatici will race for the Signatech Nissan LMP2 team in three rounds of the WEC, sharing its second ORECA-Nissan O3 with Pierre Ragues and Roman Rusinov.

STUCK GETS PRESIDENTIAL ROLE

Multiple Le Mans 24 Hours winner Hans Stuck has been named as president of Germany's motorsport authority, the DMSB. Stuck, 61, succeeds Torsten Johne.



Stuck (l) has a new job

FORMULA RENAULT 3.5

Teams confident that test problems are over

Bird 'pressed on' in testing



FORMULA RENAULT 3.5 TEAMS AND

drivers are growing in confidence that the race debut of the series' new car will run smoothly after reliability issues blighted pre-season testing.

Several teams complained of their test programmes being heavily disrupted as new-car issues were ironed out, but most reported an increase in running at the final test at Aragon, scene of this weekend's opening round.

Carlin engineer Paul Wallace told AUTOSPORT: "We've had some niggles, but they have been fairly minor. Most of

it is down to how you manage what you've got rather than any particular problems. I think by the end pretty much everyone had a handle on it."

Ex-GP2 racer Sam Bird, who is making his debut in the series with Czech team ISR, added: "There have been some gremlins but I was able to press on at the last test. Because of the problems some teams have probably got ahead on set-up, but I think we're all in a good position now."

➔ P60 FR3.5 PREVIEW

INDYCAR

Honda upgrades turbos as panel passes rule

THE INDYCAR TURBO-PARITY WAR ended last week when a series panel upheld its decision to allow Honda to introduce a new compressor cover for its single-turbo engines – although the paddock remains divided over the extent to which it has benefited from the update.

Drivers from Chevrolet and Honda-powered teams agreed that the Japanese-engined cars appeared to be stronger in a straight line at last weekend's Sao Paulo street race,

although some Honda drivers also pointed out that they were running less wing – reducing drag – than some of their Chevrolet counterparts.



RH-R: 500 qualifying key

Andretti Autosport's Ryan Hunter-Reay, who uses Chevrolet engines, said that the real picture would be revealed after qualifying for next month's Indianapolis 500.

"The straights here are a good indicator of what we're going to see at Indy, and with the Hondas being on top on the straights in some practice sessions it will be interesting," he said. "We'll know for sure after qualifying."

Chevrolet-powered cars have won all four races run so far this year.



GOES INTERCONTINENTAL

www.autogp.org | info@autogp.org

14 RACES, 4 CONTINENTS

ALL EVENTS LIVE ON EUROSPORT IN 87 COUNTRIES

7 EVENTS, ALL PARTNERING

550 BHP OF ZYTEK V8 POWER



THE BEST SCHOOL FOR F1

- Double compound **KUMHO TYRES**
- Overboost system for more overtaking
- Longer Race 2 with mandatory pit-stop



Auto GP 2012 Calendar:

10-11 March Monza (I)
 31 March-1 April - Valencia (E)
 14-15 April - Marrakech (MA)

5-6 May - Budapest (H)

2-3 June - Portimao (P)
 21-22 July - Curitiba (BR)
 22-23 September - Sonoma (USA)



PLATO SHUNTS BUT RECOVERS

British Touring Car Championship leader Jason Plato and his MG6 bounced back from a car-wrecking shunt in Thruxton qualifying last weekend to finish in the top four in all three races.

IN BRIEF



More Status for Buurman

LE MANS DRIVE FOR BUURMAN

Dutchman Yelmer Buurman will return to the Status Grand Prix LMP2 squad for the Spa and Le Mans 24 Hours rounds of the World Endurance Championship rounds. He will share the team's Lola-Judd/BMW B12/80 with Briton Alexander Sims and Frenchman Romain Iannetta.

BEECHDEAN FOR SPA ENDURO

Beechdean Motorsport will contest the Spa 24 Hours in July. Aston Martin Racing head John Gaw, team boss Andrew Howard, Phil Dryburgh and Jonny Adam will drive the Aston Martin Vantage V12.

NEW FORMAT FOR DTM MUNICH

The DTM has introduced a new relay format for the Saturday of its Munich 'Show' event in the city's Olympic stadium on July 14/15. Two drivers from each manufacturer will pair up, with two stints for each.

ALMIROLA'S NEW CREW CHIEF

NASCAR Sprint Cup team Richard Petty Motorsports has hired Denny Hamlin's former crew chief Mike Ford to replace Greg Erwin in running the #43 Ford Fusion of Aric Almirola.

BRISTOL BANKING CHANGES

Bristol Motor Speedway will modify its banking before the NASCAR Sprint Cup returns in August. The 0.5-mile oval has lost spectators since 2007, when its progressive banking was first used.

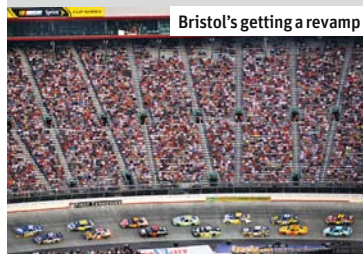

Bristol's getting a revamp

BTCC

Neal: no more NGTC Hondas

Team Dynamics rules out building more cars due to BTCC equalisation rules

British Touring Car Championship squad Team Dynamics is not planning to build any more NGTC Honda Civics due to the current state of the series' equalisation regulations.

Dynamics has built Civics for its own works Honda team and the independent Eurotech squad this season. There had been a possibility of further customer cars, but Dynamics believes the series' rolling equalisation system discourages the company from building more.

Changes to the permitted boost levels for the cars are based on the best qualifying and race laps set by each model over the past two race

weekends. A quick lap by any one driver in a given model therefore affects all drivers of that car.

The first changes of 2012 were introduced before Thruxton last weekend, and only the NGTC Civic and MG6 were not given extra boost.

Dynamics driver Matt Neal, whose family owns the team, said: "If our cars are carrying [success] ballast and others in the same car are running lighter and go quicker, we get penalised as well.

"It's not in our interests to sell cars. We want to and there are people interested, but we're not planning on building any now."

THRUXTON BEST LAP TIMES

Qualifying

NGTC Honda Civic (Andrew Jordan) 1m16.983s

MG6 (Jason Plato) 1m17.807s

Toyota Avensis (Frank Wrathall) 1m18.002s

Ford Focus (Mat Jackson) 1m18.451s

Vauxhall Vectra (Dave Newsham) 1m18.578s

Race (worse weather conditions)

NGTC Honda Civic (Gordon Shedden) 1m23.167s

Toyota Avensis (Wrathall) 1m23.928s

Vauxhall Vectra (Newsham) 1m24.039s

MG6 (Plato) 1m24.070s

Ford Focus (Jackson) 1m24.700s



P36
BTCC
THRUXTON

MIS Motorsport - setting the standards in motorsport insurance

ON TRACK / ON EVENT / MOTOR TRADE /
PERSONAL ACCIDENT / COMMERCIAL / LIABILITY

www.mismotorsport.com or call 01943 884 555

M.I.S. Motorsport Ltd is authorised and regulated by the Financial Services Authority.

MIS
MOTORSPORT

WRC

SALAZAR SUPERSTAR

Ex-Formula 1 driver Eliseo Salazar finished last week's Rally Argentina in 12th place. The Chilean said: "I have started the Monaco GP, Dakar, Le Mans, the Indy 500 and a round of the WRC – I don't think anybody will beat that record for a while."



WRC

Historic events face 2013 axe

Legendary events the Acropolis and New Zealand face calendar cull for next season, writes DAVID EVANS

The Acropolis Rally – one of the oldest and most well-established rounds of the World Rally Championship – is one of two cornerstone events dropped from the calendar for next season.

The calendar is due to be discussed by the WRC Commission next week, and AUTOSPORT's sources have confirmed details of a 12 or 13-round schedule, with New

Zealand, another founding round of the series, also being dropped. Britain's round is included, with a shift north to Sunderland and a return to a traditional November date reportedly the most likely option for Rally GB.

Four non-European rounds are expected to be included, with Argentina, Mexico and Australia the established long-hauls on the list. Brazil and South Africa are thought likely to be included, but both countries are expected to run candidate events this season that will be inspected by the FIA before either is confirmed. Brazil still has three alternatives to put forward, one based in Curitiba, one out of Sao Paulo and the other – believed to be the preferred option – will

start in Rio de Janeiro and finish on Copacabana beach.

While precise dates remain flexible, if there are two South American rounds, one option is believed to run Brazil first and Argentina a fortnight later.

The South African event is likely to be based in Durban, but some sources admit inclusion in next season's WRC calendar could be too soon for the candidate event.

The other European rallies included are Monte Carlo, Sweden, Portugal, Catalunya, France, Finland, Germany and Italy – although there is a question mark over the Sardinian event.

A source within the FIA said: "The calendar is just about there now and there won't be any major

changes. It's going to be 12 or 13 rounds and it seems there is an acceptance that this year's trip to New Zealand will be the last one for the WRC. The story with Acropolis is based around the current financial situation for the country [Greece]."

Citroen team principal Yves Matton said: "We have not seen the calendar yet, but if New Zealand is going, this is logical for us – we have no interest in going there. It costs a lot of money and can easily be replaced by a rally with more interest. Sure they have nice stages, but this is not enough. For Greece, this is an event with nice stories, and this is not an event the manufacturers are saying they don't want [in the calendar]."



Greece faces uncertain future

WRC

Citroen boss: team comes before drivers

CITROEN TEAM PRINCIPAL YVES MATTON says he would be happy to tell eight-time world champion Sebastien Loeb to slow down for Mikko Hirvonen if it secured the best result for the French firm.

Despite the Citroen team-mates being just 2.1 seconds apart mid-way through last week's Rally Argentina, Hirvonen was instructed not to challenge Loeb after

the pair had moved comfortably ahead of Ford driver Dani Sordo in third.

"Yes," said Matton. "I would ask him [Loeb] to slow down. For the manufacturers' championship I have no choice but to do it like that. For me, it doesn't make a difference [if it's Loeb or Hirvonen in front]. I need the manufacturers' title and one driver as a

world champion, but I have no name for who that will be right now."

Asked whether he would have slowed down, Loeb replied: "What can you say? For sure, it's frustrating [for Mikko], but the team is the most important thing."

On hearing the news that Loeb might slow for Hirvonen in future, the Finn responded with: "We'll see".

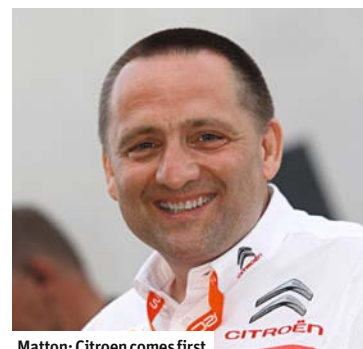

Matton: Citroen comes first

WRC

Argentina plans to up ante in '13

AFTER RUNNING THE LONGEST conventional WRC round in 16 years, Rally Argentina organisers are ready to make the event even tougher for next season.

Last week's Villa Carlos Paz-based round ran to 312 competitive miles, almost a third longer than most rallies in the championship. The event received mixed reviews from the manufacturers, with Ford team director Malcolm Wilson concerned at the hike in costs associated with running extra mileage.

Despite such criticism, event clerk of the course David Eli is determined to further the challenge presented next season.

Eli said: "We are looking at more



Argentina drew mixed reactions

[competitive] distance next season, but we want to reduce the liaison mileage between the stages. We want fewer stages, but more longer stages – we want more stages like the 41-mile stage we ran this year."

Also on the bill is another shot at running a ceremonial start out of the nation's capital Buenos Aires.

"We tried this before [in 2008], but it was very difficult because of the weather," said Eli. "But we want to try again. To include Buenos Aires in

the route is very important to us."

Rally winner Sebastien Loeb admitted he enjoyed the longest event of the season. "The stages are very nice and the atmosphere, but I wouldn't like too many rallies this long."

Wilson added: "We're very much in favour of the long stages, but we're certainly not happy with the distance and, for me, the rally was over on Saturday. All we've seen for [the final] day and a half is a procession. Is that what we really want?"

AUTOSPORT SAYS...

DAVID EVANS
RALLIES EDITOR

david.evans
@haymarket.com



Much as I enjoyed last week's longer-distance Rally Argentina, there were a couple of aspects providing concern.

The first issue was the depth – or lack thereof – of competition. Admittedly, Ford's purposeful challenge to Citroen was halved when Jari-Matti Latvala made shoulder-first contact with Finland last month, but when Petter Solberg's charge was stymied by a solid piece of South America, the WRC was left as exposed as the Norwegian's geological nemesis. And Dani Sordo, with one day testing the Fiesta, could hardly be expected to carry the fight to the DS3 WRCs.

The event afforded the younger drivers an amazing opportunity to drive sensibly, keep their noses clean and pick up a great result. Mads Ostberg is not included anymore. He might be young, but podium finishes are now almost expected from the super-talented Norwegian. But what about Evgeny Novikov, Thierry Neuville and Ott Tanak?

Each needed to go the distance to pick up as much experience as possible. They all failed, providing me with my second fear. And Tanak failed more miserably than most. A puncture followed by steering damage and finally an accident in as many stages on Friday was inexcusable for one with this opportunity.

The young driver who excelled was Andreas Mikkelsen, who mostly showed his more senior team-mate Sebastien Ogier the way home.

Rally Argentina was well-organised and brilliantly supported. It deserved better.

Tanak didn't stay like this for long



IN BRIEF

DOUBLE BILL FOR PETTER

British rally fans will get to watch Petter Solberg in action twice in as many months after the organisers of Rallyday (Castle Combe, August 18) confirmed the Norwegian would make his debut at the event. He will drive a factory Ford Fiesta RS WRC. The 2003 world champion will be back in Britain a month later for Rally GB.

FIRMS BID FOR WRC ROLE

Global sports media management firm IMG and a group of Qataris are the two names most strongly linked to the WRC promotion role currently being negotiated by the FIA. Further news on who will guide the commercial side of the series from next season onwards is expected this week. The European Broadcast Union has been awarded a deal to film and distribute footage from the 2012 WRC.

WILSON BACK FOR GREECE

Matthew Wilson has confirmed he expects to be fit for the next round of the WRC, the Acropolis Rally later this month. But the Cumbrian's deal to drive a Ford Fiesta RS WRC – in the same team as Henning Solberg – is still being worked on as AUTOSPORT closed for press.

HUFF FOR CORSICA IRC

World Touring Car Championship frontrunner Rob Huff will drive a course car through the stages of the Tour de Corse rally for one day during the IRC event in a deal that's understood to have been organised by the Chevrolet driver's employers.

DELECOUR'S ISLAND PLAN

Francois Delecour is set to contest the Tour de Corse for the 13th time this year. Delecour, who won the French island rally in 1993, has been linked to a Automeca-run Renault Megane RS drive on the May 9-12 round of the IRC. Delecour would be co-driven by Dominique Savignoni who would come out of retirement (announced at the Monte Carlo Rally in January) to compete.

BARRETT TOPS FESTIVAL

Kevin Barrett won the Festival of Speed, Long Kesh in Northern Ireland on Saturday. The Subaru Impreza WRC driver defeated the similar car of Kenny McKinstry on a stage constructed on roads around the old Maze Prison.

Barrett got out of jail free



Latvala will test again next week

WRC

Latvala ready to return for Acropolis

FORD DRIVER JARI-MATTI LATVALA will be back in a Fiesta RS WRC next week, testing for the first time since he broke his collarbone on April 11.

The Finn will take part in the team's pre-Acropolis Rally test in Sardinia, driving for two days.

"It'll be great to get Jari back in the car," said team director Malcolm Wilson. "He's had some padding made to go over the area where he broke his collarbone, but he hasn't been feeling any pain since two days after the accident. We're 99.9 per cent certain he will be competing with us in Greece."

Latvala is undergoing physiotherapy and was hoping to drive some of his own rally cars in the run up to the test.

"I am 90 per cent recovered and ahead of schedule," he said. "I am confident for Greece."

Latvala missed last week's Rally Argentina, where Spaniard Dani Sordo stood in at the wheel of the #3 Fiesta.

STREAKS

FORD'S UNBROKEN WRC POINTS HAUL

Last week's Rally Argentina marked the 150th rally in succession in which Ford has scored points. The run began with the 2002 Monte Carlo Rally, where Carlos Sainz and Colin McRae finished three-four for the Blue Oval.



SHINE ON YOU **CRAZY** DIAMOND

Gilles Villeneuve was much more than smoking tyres and three-wheeled lunacy. MARK HUGHES argues that he also had an intuition to conserve that would have made him a champion in the right car

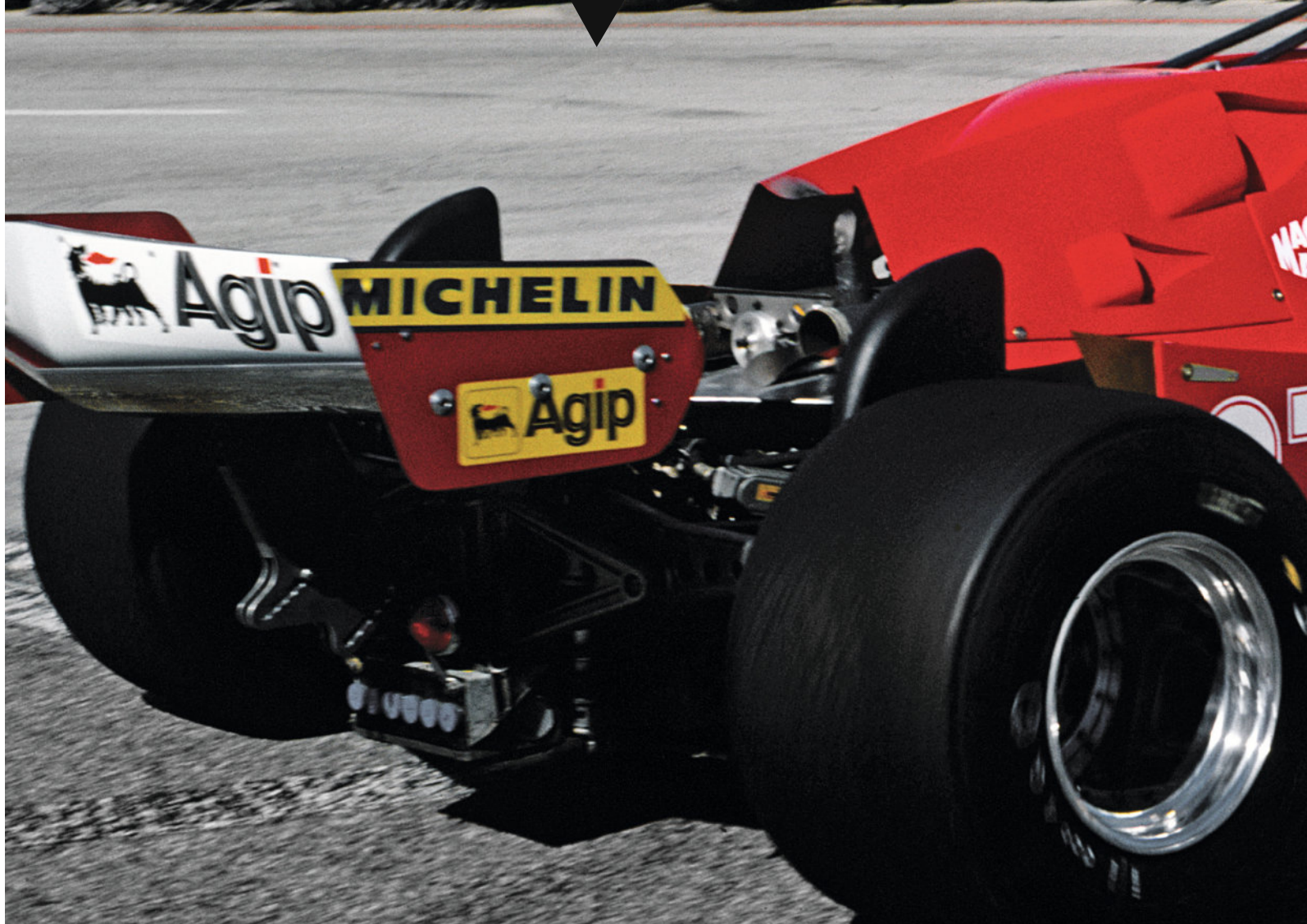

Gilles Villeneuve's fatal accident at Zolder 30 years ago has freeze-framed a certain image of him that's only partly true: a crazy beauty of a driver; a cracked genius destined never to fulfil his potential, way too brave in a lethally dangerous sport ever to make old bones. Had his time played out, the other facets of this remarkable driver would have been more obvious and a more fully-formed picture would have emerged. That's not to say there was not a streak of craziness in him. That helped create the legend, but, contrary to that legend, it wasn't pervasive, wasn't what he was *all* about.

At the very core of Gilles's story is a level of natural ability that was downright freakish. Combined with that no-compromise part of his character, and the circumstances in which he found himself in an F1 career that encompassed just four full seasons, that talent made for some of the most thrillingly high-octane moments the sport has ever seen.

But the bright intensity of those moments

bleeds out details of the subtlety that he also possessed. In these details can be found the qualities that, allied to that competitive will and other-worldly talent, would have formed the bedrock for the sort of fantastic success his critics insist he wasn't capable of.

To properly assess Villeneuve's time in F1,

“We told him no way were those tyres going to last, but they did. He was like a magician with tyres”

Michelin's Pierre Dupasquier

his barely-adequate preparation needs to be appreciated. He arrived in the sport's top category with hardly any experience of the hotbed of the racing ladder in Europe. He was the king of North American Formula Atlantic, an arena that boasted drivers of the calibre of Keke Rosberg and Bobby Rahal, but which ultimately was just a national-level category.

The cars were well below F1 in grip and power, and raced on tracks that would have little relevance to his F1 career.

It's unlikely even that his domination of this series – he won nine from 10 races in 1976, retired while leading the 10th and was on pole for every round – would have been a springboard to F1 were it not for him beating his team-mate, a guesting soon-to-be-world-champion James Hunt, at Trois Rivieres.

At first Hunt could not believe that this guy could be 0.5s faster than him, and suspected that their cars couldn't be equal. For the next session the cars were exchanged – resulting in Gilles's margin increasing significantly! It wasn't just the numbers – it was the style, the very obvious way the car was being driven to its absolute limits. Hunt was blown off and blown away, and to his great credit his reaction was to rave to McLaren about this amazing talent he had just encountered.

It was this that led to Villeneuve's appearance in a third McLaren – alongside Hunt and Jochen Mass – at the 1977 ▶



Long Beach 1981, in the horrific 126CK



AUTOSPORT

INTERNATIONAL

The Racing Car Show

- **OVER 28,000 TRADE VISITORS**
- **700+ EXHIBITING SUPPLIERS**
- **5,000+ OVERSEAS VISITORS**
- **55 COUNTRIES REPRESENTED**
- **£800+ MILLION WORTH OF BUSINESS GENERATED**

Europe's largest motorsport show

10 - 13 JANUARY 2013*

*Trade only days 10 & 11 January

NEC BIRMINGHAM UK

www.autosportinternational.com/trade



AUTOSPORT.INTernational@HAYMARKET.COM



◀ British Grand Prix at Silverstone, where his speed caused a sensation.

The preparation for that race was a test session a few days before. In that time he had to learn F1, the super-fast Silverstone circuit and the car. Contrast that to the thousands of miles' testing preparation of many subsequent rookies. In an obsolete car he outqualified Mass in the latest-model McLaren, and would likely have finished fourth had he not pitted because of the readings of a faulty temperature gauge. He rejoined a lap down on the leading group of Hunt, Niki Lauda, Jody Scheckter and Mario Andretti, allowed them past, then comfortably hung onto the back of them for the remainder of the race. He set the fifth-fastest lap. From nowhere, he was suddenly on Ferrari's radar.

As can be seen, context is everything. It was an astonishing debut, but leaves little imprint on the record books. Contrast it, for example, to the F1 debut of his son Jacques 19 years later: pole position, second place and fastest lap. But that was at the wheel of F1's dominant car, with thousands of miles of pre-season testing following on from the best preparation imaginable – a thorough grounding in the junior categories and two seasons of Indycars, all with top teams. Gilles's accomplishment suggested a talent that was off the scale, but you need to be aware of the context to appreciate that.

"Gilles came into F1 with no real experience," agrees his friend and contemporary Bruno Giacomelli. "He had to learn so much more than the rest of us brought up on racing in Europe. With no international experience, he had to learn the tracks as well about F1 – and with all the pressure of being a Ferrari driver!"

He was in the Ferrari cockpit as world champion Niki Lauda's replacement for the last two races of the season – no pressure then! He would remain there for the rest of his time, during which he would convince Enzo Ferrari that here was one of just two other drivers he'd ever encountered that were worthy of comparison to the greatest of them all, Tazio Nuvolari.

"There were only two possible outcomes in [Gilles's] situation," continues Giacomelli of Villeneuve's sequence of errors in his first few Ferrari appearances, as he learned all about F1. "Either you would not be quick enough or you would have accidents. No matter how talented you were. Put anyone in that situation, with the small experience Gilles had, and they are the options. And if you're not quick enough you're not going to stay in F1. So there was only one option. Of course he had accidents at first." Context again.

When Villeneuve is mentioned as one of the greats, one of the objections to that view is that his first full season of 1978 does not stack up on the numbers. He was outqualified by team-mate Carlos Reutemann more often than not



Amazing F1 debut in 1977 British GP

"Scheckter clattered into Regazzoni, bouncing him into Villeneuve. Only that error of Scheckter's deprived Villeneuve of the 1979 title"

and comprehensively outscored by him. But that was no more than the missing parts of the personal data banks in a pre-telemetry era when they could not easily be acquired.

Of much more relevance to his potential were the peaks: at both Zolder and Monza he took the fight to the dominant ground-effect Lotus 79 of Mario Andretti, something that even the brilliantly quick Reutemann never came close to doing. Furthermore, the accidents had stopped. Andretti noted at Monza how he was pressuring Gilles for the lead, waiting for the mistake – and how it gradually became clear to him that the mistake wasn't going to come, that Villeneuve had complete control of everything he was doing. Mario was forced to put a do-or-die move down the Ferrari's inside that required Villeneuve's cooperation not to result in an accident. He gave the Lotus the necessary survival space and not an inch more, impressing the hell out of Andretti.

The first victory came in Montreal that year, a flawless performance with a fairytale ending on home ground in Quebec. But within it was a detail that belies the legend. His choice of soft tyres, which was crucial, had the Michelin guys taking a sharp intake of breath. "We told him no way were those tyres going to last," says Michelin's Pierre Dupasquier, "but they did. He was like a magician with tyres!

"I know people don't realise this because the image is of him driving with three wheels or locking up fighting Arnoux [at Dijon in 1979], but those instances were not about making the tyres last. When he again made the choice of the soft tyre for Long Beach in '79 I was again concerned, but by this time I had more faith in him because of what he had done in Montreal – and also what he had done one race before Long Beach, at Kyalami. If you remember, there he came from half a minute back to catch Scheckter, made Jody work his tyres too hard and then just cruised past."

Such performances can only come from someone with incredible sensitivity, and it was underlined when the dog of the car that was the Ferrari 312T5 in 1980 often couldn't even do a race distance without a tyre change. Villeneuve invariably got the tyres to last longer than team-mate Scheckter before having to stop, despite almost always running well ahead of him.

The performances of the pair had been more closely matched in 1979, the year they gave Ferrari a one-two in the championship, but with Scheckter ahead. Jody had joined as number one, Gilles in just his second full season, assigned a support role. But in the first part of the season Villeneuve was quicker and beat Scheckter into second at both Kyalami and Long Beach, consecutive victories that had Villeneuve leading the championship.

The dropped-scores rule for 1979 was uniquely extreme in that points could be taken from only four races from each half-season, meaning anyone behind at the halfway point was going to find it extra difficult to make up the deficit in the second half, with effectively just four races in which to do it. With Villeneuve well ahead on points going into the last two races of the first half-season, Ferrari issued a statement saying that Scheckter had until Monaco (the final race of the first half) to win a race. And, should he fail to do so, the team would be obliged ▶





The stare of an uncrowned champ

◀ to switch its title focus to Villeneuve.

Scheckter promptly won the next two races, but the first of them, at Zolder, was incredibly fortuitous. An error from Scheckter on the opening lap resulted in him clattering into Clay Regazzoni at the chicane, bouncing the Williams into Villeneuve. Scheckter continued without damage, but Villeneuve was forced to pit for a new nose. Villeneuve climbed all the way back to third, but the charge had extracted a toll on fuel consumption and he ran out on the last lap. It was a costly four points, for he would go on to finish three points behind Scheckter in the championship. The fact that he came within an ace of winning the title while assigned a number-two role makes a mockery of the claim that he could not have won titles.

Only Scheckter's Zolder error deprived Villeneuve of that year's championship and, as the faster driver in the fastest car, Gilles was surely on the way to the 1982 crown before fate intervened. Had he then accepted Ron Dennis's offer to switch to McLaren, he'd have had the dominant McLaren-TAGs of '84 and '85 at his disposal. It's a nonsense to say he was not capable of winning titles.

Favourite mag: reading a report of a race he missed



The 1979 wheelbanging with Rene Arnoux at Dijon and the three-wheeling back to the pits after a puncture at Zandvoort that year are often cited by critics as evidence of a mentality that would have precluded ultimate success. That can only be a subjective call. The fighting spirit shown in the Arnoux duel won him that second place on a day he should have finished third, and two years later played a part in those astonishing wins at Monte Carlo and Jarama.

The Zandvoort puncture came in the second half of the race – a race he was leading, having passed the superior Williams FW07 of Alan Jones around the outside of Tarzan. Had he pitted, he would have surrendered all hope of victory. Driving it back on three wheels was immaterial to the loss of points, but did display the refusal to surrender that was such an inspirational part of him. But yes, it did ultimately endanger others. The nine points lost with that puncture can also be said to have denied him that title.

The cameo in the wet practice of Watkins Glen that year, when he was 9.6s faster than anyone else, was a little window into a surreal level of ability. That was when Scheckter had got out of the car convinced he would be comfortably fastest, so hard had he pushed, only to be confronted with that astonishing time. It was when Jacques Laffite conceded: "He's on a different level to the rest of us." That was a sentiment echoed at various times by Arnoux, Lauda, Patrick Tambay and Alain Prost.

He won that race despite nursing an engine with virtually no oil pressure for the last 20 laps, backing off, allowing Arnoux to unlap himself, coasting through the right-handers. Doesn't fit the cliché, does it? Like the tyre use, it's one of those forgotten details that are discarded because it doesn't seem to fit, but which is actually hugely significant. He could adopt whatever approach was necessary to win – something that would have become clearer in time as different circumstances played out.

"Gilles was an innocent believer," said Ferrari technical chief Mauro Forghieri. "He had played his role of support in 1979 and it was always clear that the role was for that season only, as this was part of Scheckter's deal. After that there would be no restrictions, no number one or two." That '79 season was supposed to



Villeneuve let Jones lead in '81 Monaco GP

"Upon joining Ferrari, Harvey Postlethwaite discovered that the 1981 car had literally a quarter of the downforce of the best British cars"

be just the beginning, the foundation, a year to be passed in contractual compliance. Looking forward to fighting for the titles that were his due without any restrictions, Villeneuve's frustrations can be imagined when Ferrari delivered the hopeless 312T5 of 1980 and the agricultural 126CK turbo car of '81.

Against a field of properly-developed ground-effect cars in 1980, the T5 was a lost cause. Just as Villeneuve's career should have been blossoming into full flower, he was consigned to this. But the moments of magic continued. In Argentina he had the car up to second place, keeping Jones's winning FW07 under pressure and pulling away from Nelson Piquet's Brabham BT49, cars that were in an entirely different class. Suspension failure took him out there. In Brazil he amazingly led after somehow qualifying third. In Monaco he was running fifth in the late stages when it began to rain. Suddenly he was the fastest



Dutch GP '79 blowout arguably cost title

man on the track by between three and five seconds! Had the race continued for another few laps, a sensation was on the cards.

He delivered an even better one there a year later, with an unlikely victory in the truck-like 126CK. After losing pole to Piquet's illegally light Brabham by hundredths of a second, he was the beneficiary when Jones's engine died. Earlier, he had allowed Jones through into Mirabeau and in that little moment was another indicator of just how all-encompassing his ability was. This was a victory won only partly through an astonishing qualifying lap (1980 Monaco polesitter Didier Pironi in the sister car was 2.5s slower, back in 17th). It also came from using his brain, Jones pointing out that in letting him through when the Ferrari was still heavy, he'd ensured he still had brakes and tyres when it was important, and that if he'd just fought the lighter Williams he'd have been nowhere later on. Again, one of those details that doesn't fit, but which tells us just what success would have come his way when the good car came along.

Rock apes cannot sustain a full race distance of pressure from four faster cars in a difficult handling machine, when one missed braking point or apex or gearchange would have allowed them all to barge past. That's what Villeneuve did to win at Jarama. Brabham

designer Gordon Murray said: "That was the greatest race I've ever seen anyone drive." On this day, the attack and fury Villeneuve could unleash was not the appropriate way, and he adapted accordingly.

It was all coming his way in 1982. Having turned down Dennis's offer of joining McLaren, he had at his disposal a Ferrari that at last mated the powerful engine to a decent chassis, Harvey Postlethwaite having been enlisted to introduce British technology to Maranello. Upon joining, Harvey discovered that the '81 126C had literally a quarter of the downforce of the best British cars. Postlethwaite's 126C2 was Renault-quick but vastly more reliable, and would likely have breezed Villeneuve that year's championship. Gilles didn't get to race it at its



Duped by Pironi in 1982 San Marino GP

best, its handling transformed once it was switched to pullrod front suspension from Zolder, although he would have won Imola but for Pironi's scheming.

The events of Imola – when Pironi disingenuously interpreted a 'hold-station' pit signal in his favour rather than, as intended, Villeneuve's (who was leading when the signal was prepared) – shocked Gilles. He'd never played the politics game, didn't realise how vulnerable this made him to someone of Pironi's disposition. He was the world's fastest driver, he had all the supporting attributes to that in the car – even though some of those were underappreciated. But out of the car, this 'innocent believer' was duped and it enraged him. He was probably not in a balanced state of mind two weeks later when, up ahead, he saw a slow car as he was out to beat Pironi's qualifying time...

In the following few seconds F1 lost its greatest exponent of the day, one of the greatest of all time. Behind the human tragedy, the sporting one is that his greatest days were still ahead of him, days when the true picture of his level would surely have played out so brightly that no-one could have been in any doubt. Forget the numbers, look at the context and the details. ❖



RALLY OF ARGENTINA

Villa Carlos Paz,
April 26-29

ROUND 5/13

WINNER

Sebastien Loeb
5h34m38.8s

QUALIFYING STAGE

Sebastien Loeb

POWERSTAGE WINNER

Petter Solberg

RALLY RATING



Brilliant Friday gave
way to a long weekend

DRIVERS' STANDINGS

Loeb	91pts
Solberg	73pts
Hirvonen	70pts

MILESTONES

- Ford's 150th consecutive points score
- Dani Sordo's first start in works Ford

DAVID EVANS
reports



Seven-up for Seb in South America

Loeb's seventh Argentina win is assured
after 'protection' from team-mate Hirvonen



ENDURANCE: THE ABILITY TO endure a difficult process without giving way. Citroen and Sebastien Loeb didn't give way better than anybody in Argentina last week on the longest conventional (non-Safari) round of the World Rally Championship since this event in 1996. Ford's failure to provide a sustained challenge to the French force provided another take on the whole endurance theme, with Loeb's victory over team-mate Mikko Hirvonen certain from Saturday lunchtime onwards. The balance of what should have been a thriller turned into a long rally that had to be... endured. Ford could celebrate 150 consecutive point-scoring finishes in the WRC and a Powerstage

success for Petter Solberg, but that was small fry in comparison with another all conquering effort founded in Versailles.

LEG ONE (123.01 miles) OVERCAST - AMBIENT TEMPERATURE RANGE ON STAGES 6-15C

Loeb wanted this one. So he took it. Despite the early onset of a southern-hemisphere winter that looked ready to wash out and possibly freeze the fifth round of the championship, Loeb was adamant he wanted one of his two sets of soft Michelins for qualifying.

He put them to good use, won the stage and duly booked his place first into all 120 miles of day one. Conventional wisdom on gravel rallies is the further

back the better, allowing those ahead to sweep the loose stones and uncover the best possible grip. But when the rain comes, that theory goes out of the window.

"If we run 15th on the road, it would be very difficult," said Loeb. "We need to be first."

Having booked his top spot on softs, Loeb promptly shipped 10 seconds to Petter Solberg on Thursday night's superspecial on the outskirts of Villa Carlos Paz, by running hard Michelins.

"It was a very bad choice," said the eighth-placed eight-time champion.

Solberg was delighted with SS1 and continued in the same vein after a delayed start on Friday morning - the tanker carrying petrol to the refuel broke down and

an hour was lost while a replacement was sourced.

Petrol in place, Loeb turned in a near-perfect first stage proper. He was beaten on only one of the eight split times in the loop out and back to the village of La Pampa. But he wasn't smiling at the finish.

"I had a spin," he said. "The feeling is not so good: too much oversteer."

Solberg's hopes of extending his advantage had been hit by a bizarre

problem. Opening the door at the end of the test, Solberg grimaced, pointing at the pedals of his Fiesta. "Look," he said. "It was under the pedals. We were close to going off the road twice."

Part of the foam padding that sits between Solberg's seat and the roll cage had worked loose and was rolling around in the footwell. Hirvonen was third quickest, with Solberg's imported Spanish team-mate Dani Sordo behind him on the

... after beating Citroen team-mate Hirvonen





Solberg retired from P1 but later salvaged P6



Loeb took a 70th career WRC win...

stage but 2.1s up on the leaderboard.

On the eve of this event, the universal maxim being trotted out service park-wide was the need to make it through day one on this the longest WRC stage event since 1996.

Maybe Evgeny Novikov and Ott Tanak should have listened longer. Novikov smacked a rock on the outside of a left-hander, kinking his right-rear; Tanak punctured the same wheel.

One stage later and the wounded wheel parted company from the Russian Ford, while Tanak's car sported front-left damage and a broken steering arm. Some 18 minutes went begging while he replaced it. Worse was to follow for the Estonian as he went off the

road on the day's third stage.

Words almost failed Ford team director Malcolm Wilson. "What to say about Mr Tanak?" pondered the Cumbrian, before carefully adding: "What has happened today is completely unsatisfactory."

He saved further comment for the man himself.

The positive news from the morning was Solberg's fastest time in SS3. Two more spins from Loeb were enough for the gap at the front to mushroom to 20 seconds. And the leader's run through the 32-miler hadn't been trouble-free.

"We bent a rear arm," he said, "we touched a bank."

Loeb dropped from second to a disgruntled fourth.

"The car is snapping when I get on the power at the exit

of the corner," said Loeb. "I am fighting the car. I made the mistakes, but it's not so easy to drive like this."

Loeb had tested a new differential/damper combination ahead of this event and elected to run with it on day one.

Citroen team principal Yves Matton confirmed there would be changes to the #1 DS3 WRC in service.

"The test is not the rally," said Matton. "At least Sebastien has shown he is human this morning. But we will have the normal Seb back this afternoon."

He wasn't wrong.

With his car back under his complete command, Loeb turned in a superlative middle loop.

For Ford, there was more misery. For the second event

in succession Solberg retired from the lead. Following the ruts mid-way through La Pampa, the P1 Fiesta clouted a rock, bending the steering. Solberg pressed on, only to have the steering fail on sixth-gear take-off over a crest. He avoided crashing the car, but did hit another rock with the right-hand suspension.

Solberg repaired the left-hand side TCA, got back in the car and discovered 10 metres down the road that the same component had broken on the other side.

He was told to park it. "There was nothing I could do," said Solberg. "We had to follow the ruts and the rock was sitting right in there. I can't believe this."

Hirvonen replaced him at the front, but was immediately under pressure from Loeb – with his team-mate moving into a 1.1s lead after the day's re-run longest test from Ascochinga to Agua de Oro.

"I am happy now," said Loeb. "I had to push very hard through these two stages. I lost time this morning and wasn't sure I could make the time back. I had no balance with the car this morning, but now it's back."

The Finnish Citroen had been pretty much level-pegging with the tricolored version until the mid-point of the stage just east of La Cumbre. The second half of the stage is littered with hairpins, twistier and more technical, and it was here that Hirvonen lost the lead.

"I was trying to force the driving again," he said. "The road is softer and there were ruts, it's just wasn't so nice

and I knew immediately the time was going."

Ambushed by local media apparently determined to get Hirvonen to admit to a contractual clause stating he would always promise to follow Loeb home, the former Ford man scuppered the hacks' hopes by hitting back in the day's final stage to end the day just a tenth off Loeb.

"That's crazy," smiled Hirvonen, sitting down and grabbing a Red Bull.

Can open, he paused. "How many kilometres have we done today? And a tenth between us. Totally crazy!"

Sordo was a hugely credible third at the end of the opening day and had been right in touch with the lead fight until the day's final stage, when he ran hard tyres and dropped 20s to the Citroens.

"I'm happy," said Sordo, looking anything but happy. "The day has been OK."

Sordo was experience personified as those around fell apart in the face of the rally's longest day. And he was quick too – especially in the middle section of the Ascochinga stage, where he was faster than anybody – but he needed more testing to turn good great. And there was no time.

"I don't want to change the car too much, I need the confidence," he said, before adding, with frustration writ large across his face: "I'm not frustrated."

Portugal winner Mads Ostberg was fourth, despite engine trouble in SS4 and a dodgy intercom in the following stage. Nasser Al-Attiyah was one place further back, having ▶



Prokop took best-ever finish with P4



Ford stand-in Sordo ran in third but was cruelly denied

STAGE TIMES

SS1 PARQUE TEMATICO CARLOS PAZ 1 (3.75 MILES)

Fastest: Solberg 4m54.9s
Leader: Solberg

SS2 LA PAMPA-LA PAMPA 1 (23.20 MILES)

Fastest: Loeb 23m12.5s
Leader: Solberg

SS3 ASCOCHINGA-AGUA DE ORO 1 (32.23 MILES)

Fastest: Solberg 37m50.7s
Leader: Solberg

SS4 LA PAMPA-LA PAMPA 2 (23.20 MILES)

Fastest: Loeb 22m56.3s
Leader: Hirvonen

SS5 ASCOCHINGA-AGUA DE ORO 2 (32.23 MILES)

Fastest: Loeb 37m21.8s
Leader: Loeb

SS6 COSQUIN-VILLA ALLENDE (11.91 MILES)

Fastest: Hirvonen 13m36.7s
Leader: Loeb

SS7 SAN AGUSTIN-SANTA ROSA 1 (19.55 MILES)

Fastest: Loeb 12m41.3s
Leader: Loeb

SS8 AMBOY-SANTA MONICA 1 (12.63 MILES)

Fastest: Hirvonen 10m40.5s
Leader: Loeb

SS9 INTIYACO-GOLPE DE AGUA 1 (24.69 MILES)

Fastest: Hirvonen 22m48.1s
Leader: Loeb

SS10 SAN AGUSTIN-SANTA ROSA 2 (19.55 MILES)

Fastest: Solberg 12m32.3s
Leader: Loeb

SS11 AMBOY-SANTA MONICA 2 (12.63 MILES)

Fastest: Solberg 10m30.4s
Leader: Loeb

SS12 INTIYACO-GOLPE DE AGUA 2 (24.69 MILES)

Fastest: Solberg 22m36.2s
Leader: Loeb

SS13 PARQUE TEMATICO CARLOS PAZ 2 (3.75 MILES)

Fastest: Neuville 4m49.4s
Leader: Loeb

SS14 MATADERO-ANBUL (40.85 MILES)

Fastest: Solberg 38m16.0s
Leader: Loeb

SS15 MINA CLAVERO-GIULIO CESARE 1 (10.81 MILES)

Fastest: Solberg 15m38.1s
Leader: Loeb

SS16 EL CONDOR-COPINA (10.14 MILES)

Fastest: Solberg 13m17.5s
Leader: Loeb

SS17 MINA CLAVERO-GIULIO CESARE 2 (10.81 MILES)

Fastest: Solberg 15m29.3s
Leader: Loeb

SS18 EL CONDOR-CASILLA NEGRA (6.93 MILES)

Fastest: Solberg 9m37.6s
Leader: Loeb

SS19 COPINA (2.57 MILES)

Fastest: Solberg 2m32.9s
Leader: Loeb

benefitted from the woes of his Citroën Junior Team team-mate Thierry Neuville who had impressed with an early fourth before he clattered his Citroën into fourth-stage retirement.

POSITIONS AFTER DAY ONE

1 LOEB/ELENA	2h20m30.6s
2 HIRVONEN/LEHTINEN	+0.1s
3 SORDO/DEL BARRIO	+33.1s
4 OSTBERG/ANDERSSON	+1m18.4s
5 AL ATTIAH/BERNACCHINI	+5m16.9s
6 PROKOP/HRUZA	+6m24.2s

LEG TWO (103.48 miles)

OVERCAST THEN SUNNY - AMBIENT TEMPERATURE RANGE ON STAGES 8-17C

Having used all their allocation of soft tyres on the opening leg, the drivers were faced with being increasingly imaginative in the combinations of used soft and new hard — with some having a couple of hard boots to run on the road section in an effort to save the precious softer rubber for the stage. Loeb left service with hards on the right and softs on the left, while Hirvonen elected for hard at the front and soft at the rear. Loeb was quickest and lengthened his lead to 3.9s. Sordo slipped further back, having taken well-worn softs all round, only to find the stage was drier than expected — his Michelins wilted and cost him another 12s to the lead duo.

The next two stages were faster than the first. And they had more crests and jumps. Fast roads with crests? Sounds like somewhere we go in August and somewhere Hirvonen

knows how to drive very, very quickly.

"It's just like home!" beamed the Finn arriving at the end of SS8. "I love it, it's so quick."

And he was quick — 1.5s up on Loeb. Both Citroën drivers knew it was approaching that time when their boss, Yves Matton, would be pondering a lunchtime chat. Struggling for confidence in his pace notes, Sordo was now a minute back. Being lead DS3 WRC when they sat down to a plate of pasta could have serious ramifications for the finish tomorrow. Which was probably why, when he saw the times, Loeb was a little downhearted at the end of SS8.

In an effort to stamp his authority on this event, Loeb got the hammer down in the next one — determined to show that as a two-time Finland winner himself — he could deal with a bit of air as well. Quicker over the first half of the stage, by as much as 3.8s at the third split, Loeb had a heart-stopping moment further in.

"I don't know how we are here," said the leader, smiling the smile of a man who knew he'd just got away with the logically un-get-away-withable. "We went out of the road in fifth gear, hit a rock and came back. After that, I lost a bit of confidence for the rest of the stage and Mikko came back in the split times."

Fortunately for Loeb, he retained enough confidence to keep the lead. Hirvonen

beat him, but only by 0.3s. The pair was split by 2.1s when the door into Matton's office shut.

When it opened again, we had a winner: Loeb.

"I have fixed the positions," said Matton, shifting uneasily as he spoke. "On a human level, this was a difficult position after what happened with Mikko in Portugal, but both of the drivers said they were fighting a very high tempo and with the gap to Dani, we couldn't risk anything."

Citroën's decision was understandable and infuriating in equal measure. But the upshot was, the fight was finished.

Sordo remained an untroubled third, with Ostberg tending a six-minute advantage over Martin Prokop's fifth-placed, DMACK-shod Fiesta, which had moved up one place after Al-Attiah bounced his DS3 off a rock, shattering the rear suspension in SS9.

The day-two top six was rounded out by Sebastian Ogier in the leading VW-run Skoda Fabia. He and team-mate Andreas Mikkelsen were enjoying a thriller of a fight, with the Norwegian having led the duo until the penultimate stage of the day. Just five seconds separated them with one day to go.

POSITIONS AFTER DAY TWO

1 LOEB/ELENA	3h57m40.8s
2 HIRVONEN/LEHTINEN	+7.2s
3 SORDO/DEL BARRIO	+1m46.9s
4 OSTBERG/ANDERSSON	+3m06.1s
5 PROKOP/HRUZA	+9m22.5s
6 OGIER/INGRASSIA	+10m26.7s



F1 veteran Salazar took 12th for Mini

LEG THREE (82.14 miles)

SUNNY - AMBIENT TEMPERATURE RANGE ON STAGES 3-18C

What was Hirvonen doing? Had career suicide suddenly become an attractive proposition? The split times didn't make much sense on Sunday morning. Just over seven seconds down on leader Loeb going into the morning, Hirvonen slashed that gap to two tenths after two stages into Sunday. The #2 DS3 actually took the lead a mile into El Condor, beating Loeb through the first sector by 1.1s. Hirvonen then reacquainted himself with yesterday's deal and slipped back into line.

Citroen clearly wasn't too concerned, with the team's PR offering a rudimentary analysis. "Yes," she said, "Seb did have a problem this morning; he was driving like his grandmother!"

Clearly blessed with a super-quick granny, Loeb steered his Citroen home for a 70th career win and a seventh successive South American success. Hirvonen, the perfect wingman, came home second.

Attempting to provide some cheer in the blue corner of the service park, Solberg grabbed the three extra points for a final-stage win and elevated himself to seventh. That was about to become sixth, in the worst way possible for Ford.

Curious as to why he hadn't heard Sordo's time for the Copina test, Solberg enquired as to his teammate's whereabouts. His jaw was on the floor when he was told an alternator problem had halted the third-placed Fiesta just a mile or so from the end.

With Sordo gone, Ostberg collected his third podium from four starts in another

brilliant display from the privateer. There was more cheering for Prokop's fourth - a best ever for the Czech driver and DMACK tyres. Neuville recovered from his first-day roll to defend his position from Solberg. Fifth - and his best finish - was his reward. Ogier collected seventh behind Solberg. The VW-run Skoda driver won what was the battle of the rally between him and Mikkelsen - the latter's heroic run coming to an end with suspension failure in Condor.

So, Citroen's Portuguese nightmare has been erased, replaced with sleepless nights for Ford in South America. Twelve hours, five miles high heading east across the Atlantic would provide a half-day party on Air France, while the plane bound for the north of England would be rather more subdued. ☼

PWRC

Guerra plays the long game for second victory

Those expecting the 41-mile Matadero-Ambul test to prove conclusive in the direction of overall Rally Argentina honours were disappointed - Citroen's deal was done a day before. But, Sunday morning's longest stage of the season did undo Nicolas Fuchs' 50-second lead in PWRC to leave Benito Guerra celebrating a second consecutive PWRC win.

The Peruvian's Mitsubishi suffered a heart-breaking clutch problem on the monster test, dropping him back and into the clutches of fellow Lancer driver Guerra.

Fuchs was understandably distraught, having been at the front for much of the toughest-ever PWRC round.

Fuchs led the event from the start, but was chased hard through Friday by local hero Marcos Ligato. Ligato's Subaru was just two seconds down on Fuchs going into the penultimate day-one test, where steering-rack failure left him fourth at the end.

Michal Kosciuszko stepped forward to end the day just 5.9s off the leader.

Two stages into day two and it was Kosciuszko's turn for that sinking feeling. The underside of his Mitsubishi collided with one South American rock too many and the oil light flickered into life in the cockpit. One stage later and he parked the

car up with no oil pressure.

That left Fuchs more than a minute clear of Guerra. The leader throttled back, but didn't dare dream of that first win.

"There was," he continually reminded reporters - and himself - "still a very long way to go in this rally."

And then came the big one. And Fuchs' clutch failed.

It was hard to find any consolation for the former leader who arrived at the end of the stage having been passed in the stage by Guerra.

"I don't believe it." The voice trailed away, his face contorted with emotion.

Fortunately for Fuchs, he was so far ahead of third-placed Ukrainian Valeriy Gorban (Lancer) that his tenure of the runner-up spot was safe.

Fuchs' despair delivered delight for Guerra, who was really pleased with his tactics over the three days

"This is fantastic," said the winner. "I was determined not to risk anything in this rally. I knew that taking a steady drive could be the right way to go."

Gorban remained P3, with Ligato fourth ahead of fellow Subaru man Gianluca Linari.

But at the front, there was further evidence of the fable involving a land-dwelling reptile and a long-legged rabbit; not for the first time, it had been the tortoise showing the hare the way.

RESULTS

Rally Argentina, April 26-29, round 5 of 13

19 SPECIAL STAGES, 312.396 MILES

POS	NO	DRIVER/NAVIGATOR	CAR	TIME
1	1	Sebastien Loeb/Daniel Elena	Citroen DS3 WRC	5h34m38.8s
2	2	Mikko Hirvonen/Jarmo Lehtinen	Citroen DS3 WRC	+15.2s
3	10	Mads Ostberg/Jonas Andersson	Ford Fiesta RS WRC	+3m10.4s
4	21	Martin Prokop/Zdenek Hruza	Ford Fiesta RS WRC	+9m45.8s
5	6	Thierry Neuville/Nicolas Gilsoul	Citroen DS3 WRC	+11m17.2s
6	4	Petter Solberg/Chris Patterson	Ford Fiesta RS WRC	+12m02.2s
7	15	Sebastien Ogier/Julien Ingrassia	Skoda Fabia S2000	+12m25.3s
8	6	Evgeny Novikov/Denis Giraudet	Ford Fiesta RS WRC	+21m10.2s
9	7	Nasser Al-Attiyah/Giovanni Bernacchini	Citroen DS3 WRC	+28m22.6s
10	5	Ott Tanak/Kuldar Sikk	Ford Fiesta RS WRC	+37m19.5s
OTHERS				
12	52	Eliseo Salazar/Marc Marti	Mini John Cooper WRC	6h15m54.7s
R	3	Dani Sordo/Carlos del Barrio	Ford Fiesta RS WRC	SS19-alt
R	18	Andreas Mikke/Isen/Ola Floene	Skoda Fabia S2000	SS18-susp

Starters/finishers: 42/27. Leaders: SS1-3 Solberg; SS4 Hirvonen; SS5-19 Loeb

CHAMPIONSHIP TABLE

POS	DRIVER	PTS
1	Sebastien Loeb	91
2	Petter Solberg	73
3	Mikko Hirvonen	70
4	Mads Ostberg	68
5	Evgeny Novikov	43
6	Jari-Matti Latvala	28
7	Martin Prokop	26
8	Nasser Al-Attiyah	23
9	Dani Sordo	21
10	Ott Tanak	16
MANUFACTURERS' POINTS		
1	Citroen Total WRT	151
2	Ford WRT	106
3	M-Sport Ford WRT	81

RALLY SUMMARY The longest WRC stage-rally since 1996, with few of last year's stages remaining unchanged in the 312-mile route. The opening day was the longest, south of the Villa Carlos Paz rally base in the Punilla Valley. Saturday moved into the Calamuchita Valley, while the final day ran east in the Traslasierra Mountains.



Guerra celebrates a second PWRC win

PWRC - Round 3 of 8

POS	DRIVER/NAVIGATOR	CAR	TIME
1	Benito Guerra/Borja Rozada	Mitsubishi Lancer EX	6h12m00.6s
2	Nicolas Fuchs/Fernando Mussano	Mitsubishi Lancer EX	+4m19.1s
3	Valeriy Gorban/Andrii Nikoiaiev	Mitsubishi Lancer IX	+6m44.6s

THRUXTON

 GREAT BRITAIN

April 28-29

British Touring Car Championship
Round 3/10



AT A GLANCE RACE 1

- Winner **Mat Jackson**
- Pole **Andrew Jordan**
- FL **Gordon Shedden**



Jordan took a spectacular pole



Honda's comeback king

Even qualifying 18th couldn't stop Gordon Shedden taking a double in appalling conditions at Thruxton

AS COMEBACKS GO, THIS WAS right up there. After losing pole due to an overboosting turbo and being forced to start 18th, Gordon Shedden's Thruxton British Touring Car weekend had looked like being one to forget.

Contact with Rob Austin and a hit from Andy Neate at the start of race one did little to dispel that thought, but thereafter the Honda driver's efforts were sublime.

The NGTC Honda Civics were the things to have at

the high-speed Hampshire circuit. They might have been the only cars other than the works MGs not to get a boost increase since last time out at Donington Park, but the Civic's fine chassis was well suited to the flowing nature of the track – and the wet weather that was a feature of the whole weekend.

Shedden dominated both free-practice sessions, a second clear in each, and all four NGTC Hondas were in the top six. They were visibly better through the chicane than their rivals.

The Scot set the quickest time in qualifying too, but a boost-regulator problem resulted in overboosting and Shedden lost his best times.

After his opening-lap moment, Shedden charged to sixth in race one, took

victory in race two from sixth on the grid, and won the reversed-grid encounter despite starting on row five. It's not often that someone passes so many cars on the way to taking a BTCC double.

"From the moment we turned a wheel in practice

to start near the back in race one thanks to an uncharacteristic qualifying crash. In the first race Neal was carrying more success ballast, but even without that he took longer than Shedden to get up to speed in race two.

"I think we're very close

"I had a little wiggle and tapped Plato, which upset the car. It went in quite hard. It's a missed opportunity"

Jordan rues his race-one crash at the first corner

the car felt good," said Shedden. "It doesn't feel like I'm doing anything particularly special. The passing is coming from the handling and I'm happy in the wet as well."

Shedden appeared to have an edge over team-mate Matt Neal, who also had

– the difference is what we can see [in the spray]," reckoned Shedden of the appallingly wet conditions. "I couldn't really see where I was in race two and Matt was a few cars back. You were driving down the straight feathering the throttle because you



Shedden has now taken four 2012 wins

RACE RATING

★★★★☆

Some good racing and fine driving in unusually difficult Thruxton conditions

MILESTONES

Jordan gives the NGTC Honda Civic its first pole; Newsham's best BTCC finish (second); Shedden is the first person to take all three fastest laps since Silverstone 2010

REPORT BTCC THRUXTON

KEVIN TURNER
reports



Shedden was in inspired form in the wet at Thruxton



Wrathall brilliantly held off Plato in the finale



Jackson kept his title hopes on track

couldn't see ahead."

Things were made worse when the windscreen wipers stopped working, something that afflicted many of the runners. Neal even briefly accidentally switched off his ignition in race two trying to reboot the electronic system that controls them.

Race three was the one race in which Neal had a good chance to beat Shedden. Fine opening laps by both took them up to second and fourth, with Neal ahead, but the reigning champion's fight with Frank Wrathall at the complex proved crucial.

"The car was getting better and better and I was hopeful starting fifth," said Neal. "I felt the car was strong and I was light [with only 0kg of success ballast],

but I just got caught out by Wrathall. I didn't think he was close enough, but he came down the inside and the contact bent the steering."

Not only did that allow Shedden by, it also gave the team concern about Neal's tyre wear, an area in which he should have had an edge over his ballast-laden team-mate. Once clear of the field, and with the Hondas running one-two, Shedden allowed Neal through to get the point for leading a lap (as he did at Thruxton last year), but the number 52 car was soon back ahead and there was no question of them battling to the end.

The Saturday woes of the works team should have allowed Andrew Jordan's

Eurotech Civic to take advantage. A great qualifying effort gave him pole after Shedden's penalty, but it all went wrong at the start of race one.

Jordan had trouble shifting into second gear, allowing Jason Plato and a fast-starting Mat Jackson to make it three abreast into Allard. The result was the Honda crashing off on the inside and Plato going off to the outside.

"I had a little wiggle that just tapped me into Plato, and that upset the car a little bit more," explained Jordan. "It went in quite hard. It's absolutely a missed opportunity."

That incident gave Jackson his chance, and he took it. The Motorbase Ford built a 2.8-second lead on ▶

Jackson takes his chance before Shedden dominates

In difficult conditions, Mat Jackson took the first race at Thruxton before Gordon Shedden showed Honda's superiority around the high-speed circuit with two fine victories.

A great start allowed Jackson's Motorbase Ford Focus to challenge front-row men Andrew Jordan and Jason Plato into the first turn. Contact there sent the Honda off to one side and the MG to the other, leaving Jackson to pull clear of the field.

Dave Newsham's ES Racing Vauxhall Vectra overcame Frank Wrathall's NGTC Toyota on the opening lap, but Jackson was already away and gone.

Wrathall soon fell behind Rob Collard's WSR BMW and a recovering Plato, who completed a move on Collard on the run to Church at around half-distance to secure third.

Shedden's charge from row nine had just taken him by Aron Smith's Focus for sixth when Motorbase man Liam Griffin crashed at Allard. The safety car was scrambled initially, but the race was red-flagged when the rescue truck got stuck. Matt Neal's recovery therefore yielded 10th.

Jackson converted pole into another 2.8s lead at the end of the first racing lap in race two, which was started behind the safety car due to the horrendous spray.

But Shedden was already up to fourth and, just two laps later, was second. Lapping around a second faster than the rest of the field, Shedden

was soon with the leading Ford and Jackson put up little defence when the Honda attacked at Campbell on lap nine of 16.

As Jackson's tyres went off he fell back into the clutches of Plato, who had taken Newsham for third into the chicane. Once again, Jackson didn't fight too hard when the MG arrived on his tail, and the Ford only narrowly held off a charging Wrathall for third.

Neal, who was lapping quickly at the end, secured fifth from a struggling (tyres) Newsham at the chicane with two laps remaining.

Tony Gilham's S2000 Honda Civic got pole for the reversed-grid race and he held the lead from Neal, Wrathall and Shedden at the end of a fraught opening lap.

A contretemps between Neal and Wrathall dropped the reigning champion back two spots, and Shedden then swept by the Toyota before the end of lap two.

Neal soon followed and both works Hondas got ahead of Gilham when the S2000 machine got off line in the complex. Once ahead the NGTC Civics streaked away, and even had time to swap positions twice before the end.

Gilham's fine efforts came to an end when he locked up and crashed at Campbell defending from Wrathall. The Toyota then came under pressure from Plato, but – despite minor contact at the final chicane – the 25-year-old held off the veteran to complete the podium.



Jackson's Ford Focus was the top S2000 runner



Race one start: Jordan exits stage left, Plato right

AT A GLANCE RACE 2

- Winner **Gordon Shedden**
- Pole **Mat Jackson**
- FL **Gordon Shedden**

AT A GLANCE RACE 3

- Winner **Gordon Shedden**
- Pole **Tony Gilham**
- FL **Gordon Shedden**

◀ lap one and was never headed. But with Shedden closer to the front in race two Jackson was never going to repeat the feat.

That was largely thanks to the 17-inch rain tyres on the Super 2000 cars (including Jackson's Focus) going off far sooner than the 18-inch equivalents on the NGTC machines. All the S2000s started well at Thruxton, but dropped back dramatically each time.

"We haven't got a tyre that will last the race," said Jackson, who dropped behind Shedden and Plato in race two. "The degradation is difficult, but it is what it is. This is the hardest place for tyres and we're top S2000 car and have two podiums.

"The Hondas are quick too – they screwed up in qualifying and we had a good one. But in race two there was no point holding them back. If we had fought, Wrathall [closing fast in his NGTC Toyota] would have got us as well."

Wrathall's fine efforts

ultimately lacked Honda-challenging strength as his Dynojet Toyota couldn't match them for tyre preservation. Plato was the other main challenger to the Civics, but the weather that helped the Hondas hindered his new MG6.

"We haven't got a wet set-up and we're not where we need to be," said the double champion, who scored a third, second and fourth. "It's very difficult to do that without testing because the track changes so much. It's nowhere near as stable as I need it to be in the quick stuff.

"Gordon's been in the groove and has a good feeling with his car. I just let him go [in race two]. If there had been two laps to go then yes, defend, but that early in the race I thought I might actually learn something by following him and I did. The difference is commitment into the fast corners."

Nevertheless, Shedden feels Honda's Thruxton domination is unlikely to



Gilham had another good meeting in S2000 Honda

"It just shows how quickly everything turns around. We were saved by the wet"
Shedden made the most of the difficult conditions



Wood and Collard are about to clash in race three

be repeated during the rest of the season. "Qualifying didn't look clever, but it just shows how quickly everything turns around," said Shedden, who still feels the Hondas are hindered by a straight-line speed deficit due to the boost restrictions. "We've got a lot of work to do before Oulton Park [the next round] because Thruxton is unique and we were saved by the wet."

Shedden is now up to second in the title race, but Plato's position at the top – despite a relatively quiet weekend aside from an impressive qualifying crash at Church – remains ominous for the rest.

"It's all about the end game," said Triple Eight boss Ian Harrison, who runs Plato's MG. "You don't have to win. You have to finish."

Plato did just that, and his confidence is high. "If it had been dry we'd have been in different shape," he added. "We've got a good set-up in the dry now and it's all going to plan." ❁

Conditions were taxing all weekend for drivers





Newsham took career-best second

REPORT BTCC THRUXTON

NEXT ROUND OULTON PARK June 9-10



DRIVER BY DRIVER

Matt Neal (10/5/2)



Qualifying crash put him on the back foot and he couldn't recover as well as Shedden.

Gordon Shedden (6/1/1)



The pacesetter all weekend and could have won all three races had he not lost pole due to turbo problem.

Jason Plato (3/2/4)



Rare qualifying smash in car not sorted for the wet, but showed good race pace to score decent points.

Andy Neate (16/16/R)



Engine-mapping issues in practice set him back, then a qualifying crash and fraught races.

Mat Jackson (1/3/6)



Maximised Focus once again to take opportunist win in R1 despite high tyre wear. Top S2000 man of weekend.

Aron Smith (7/8/14)



Strong showing, though slick-wet tyre-mix gamble for R3 didn't pay off for him.

Liam Griffin (R/17/12)



Team did great job to fix car after Griffin crashed out of R1. Took points in finale.

Rob Collard (4/7/7)



Turbo BMWs were eating their wet rear tyres, but Collard battled on. Not happy about R3 clash with Wood.

Tom Onslow-Cole (8/13/10)



There or thereabouts, but again couldn't quite match Collard and suffered same rear-tyre-wear issues.

Nick Foster (14/14/11)



Ran in top 10 in R1 until windscreen wipers stopped working. Gained R3 place after Griffin penalised.

Andrew Jordan (R/10/5)



A case of what might have been. Great pole, but R1 crash damaged the car for the rest of the weekend.

Jeff Smith (13/11/9)



Got on well with the NGTC Civic in wet, though found damp/drying conditions tricky.

Dave Newsham (2/6/18)



Great performance once more. Second S2000 until R3 slick-wet tyre mix didn't work out.

Chris James (15/R/17)



Found conditions tough going and crashed out of R2 after locking up on the approach to Campbell.

Rob Austin (R/18/13)



Continuing engine-management issues spoiled weekend. Qualifying crash followed by R1 contact.

Frank Wrathall (5/4/3)



Got better and better and demonstrated great composure in fending off Plato in R3.

Adam Morgan (R/NC/R)



Again showed flashes of pace, but misting screen/electronics hurt him. Ran out of fuel in R3...

Tony Hughes (NC/19/16)



Crashed in R1, but brought the car home after that. Well off pace in tough conditions.

Tony Gilham (11/9/R)



Another promising weekend as he learns S2000 Civic. Shame fine R3 effort ended in wall.

Dan Welch (NS/NS/NS)



Seemed to have decent pace in practice, but never got to show it as driveshaft problem forced withdrawal.

Ollie Jackson (12/15/15)



Showed some speed, but was outfumbled in wheel-to-wheel combat and made the odd error. More to come.

Lea Wood (9/12/8)



As ever, went well in wet conditions. Ambitious but honest move at chicane in R3 ended with Collard clash.

Plato continues to lead the points race



RESULTS

British Touring Car Championship, round 3 of 10, Thruxton (GB), April 28-29

GRID	DRIVER	TIME
1	JORDAN	1:16.983
2	PLATO	1:17.807
3	WRATHALL	1:18.002
4	M JACKSON	1:18.451
5	NEAL	1:18.578
6	COLLARD	1:18.626
7	A SMITH	1:18.871
8	WOOD	1:18.999
9	GRIFFIN	1:19.151
10	O-COLE	1:19.227
11	FOSTER	1:19.416
12	GILHAM	1:19.625
13	O JACKSON	1:19.628
14	MORGAN	1:19.760
15	JAMES	1:20.870
16	NEATE	1:20.883
17	AUSTIN	1:20.904
18	SHEDDEN	1:21.298
19	NEAL	1:22.152
20	HUGHES	1:26.896
21	J SMITH	1:30.592
22	WELCH	no time

RACE 1 - 14 LAPS, 32.984 MILES					
POS	DRIVER (NATIONALITY)	TEAM	CAR	TIME/REASON	GRID
1	Mat Jackson (GB)	Motorbase Performance	Ford Focus	22m36.478s	4
2	Dave Newsham (GB)	Team ES Racing	Vauxhall Vectra	+0.876s	5
3	Jason Plato (GB)	MG KX (Triple Eight)	MG6	+1.999s	2
4	Rob Collard (GB)	WSR	BMW 320si	+2.597s	6
5	Frank Wrathall (GB)	Dynojet	Toyota Avensis	+3.367s	3
6	Gordon Shedden (GB)	Honda (Team Dynamics)	Honda Civic	+4.744s	18
7	Aron Smith (IRL)	Motorbase Performance	Ford Focus	+5.522s	7
8	Tom Onslow-Cole (GB)	WSR	BMW 320si	+6.204s	10
9	Lea Wood (GB)	Team Wood	Vauxhall Vectra	+7.212s	8
10	Matt Neal (GB)	Honda (Team Dynamics)	Honda Civic	+7.971s	19
11	Tony Gilham (GB)	Gilham Racing	Honda Civic	+9.072s	12
12	Ollie Jackson (GB)	A&D Tuning	Volkswagen Golf	+9.616s	13
13	Jeff Smith (GB)	Eurotech	Honda Civic	+10.098s	21
14	Nick Foster (GB)	WSR	BMW 320si	+10.973s	11
15	Chris James (GB)	Team ES Racing	Vauxhall Vectra	+11.186s	15
16	Andy Neate (GB)	MG KX (Triple Eight)	MG6	+12.402s	16
17	Tony Hughes (GB)	Speedworks Motorsport	Toyota Avensis	-4 Laps	20
R	Liam Griffin (GB)	Motorbase Performance	Ford Focus	9 laps-accident	9
R	Adam Morgan (GB)	Speedworks Motorsport	Toyota Avensis	7 laps-misting screen	14
R	Rob Austin (GB)	Rob Austin Racing	Audi A4	2 laps-acc damage	17
R	Andrew Jordan (GB)	Eurotech	Honda Civic	0 laps-accident	1
NS	Dan Welch (GB)	Welch Motorsport	Proton Persona	0 laps-driveshaft	22

DRIVERS' CHAMPIONSHIP		
POS	DRIVER	PTS
1	Plato	129
2	Shedden	125
3	Neal	115
4	M Jackson	107
5	Collard	103
6	Jordan	94
7	Newsham	74
8	J Smith	67
9	Onslow-Cole	64
10	Wrathall	60

RACE 2 - 16 LAPS, 37.696 MILES			
POS	DRIVER	TIME/REASON	GRID
1	Shedden	24m06.754s	6
2	Plato	+3.147s	3
3	M Jackson	+6.345s	1
4	Wrathall	+6.585s	5
5	Neal	+9.858s	10
6	Newsham	+15.085s	2
7	Collard	+23.423s	4
8	A Smith	+26.406s	7
9	Gilham	+29.130s	11
10	Jordan	+29.187s	21
11	J Smith	+35.190s	13
12	Wood	+35.390s	9
13	Onslow-Cole	+37.429s	8
14	Foster	+48.032s	14
15	O Jackson	+58.937s	12
16	Neate	+1m17.297s	16
17	Griffin	+1m17.512s	18
18	Austin	-1 lap	20
19	Hughes	-1 lap	17
NC	Morgan	-4 laps	19
R	James	6 laps-accident	15
NS	Welch	driveshaft	22

RACE 3 - 16 LAPS, 37.696 MILES			
POS	DRIVER	TIME/REASON	GRID
1	Shedden	22m42.574s	9
2	Neal	+0.719s	5
3	Wrathall	+8.102s	6
4	Plato	+9.647s	8
5	Jordan	+13.264s	10
6	M Jackson	+25.112s	7
7	Collard	+41.980s	3
8	Wood	+44.687s	12
9	J Smith	+45.249s	11
10	Onslow-Cole	+50.975s	13
11	Foster	+54.136s	14
12	Griffin	+54.379s*	17
13	Austin	+1m08.744s	18
14	A Smith	-1 lap	2
15	O Jackson	-1 lap	15
16	Hughes	-1 lap	19
17	James	-1 lap	21
18	Newsham	-2 laps	4
R	Morgan	15 laps-out of fuel	20
R	Neate	6 laps-alternator	16
R	Gilham	5 laps-accident	1
NS	Welch	driveshaft	-

Race 1 Winner's average: 87.53mph.
Fastest lap: Shedden, 1m24.565s, 100.29mph.
Race 2 Winner's average: 93.79mph.
Fastest lap: Shedden, 1m23.598s, 101.45mph.
Race 3 Winner's average: 99.59mph.
Fastest lap: Shedden, 1m23.167s, 101.98mph.
* Includes one-second post-race penalty.

P40
Support races



THRUXTON

GREAT BRITAIN

April 28-29
TOCA supports
Round 3/10



CARRERA CUP AT A GLANCE

- Race 1 Michael Meadows
- Race 2 Daniel Lloyd
- Points lead Meadows



Meadows won first Carrera Cup race



Lloyd chased down Butcher for victory

PORSCHE CARRERA AND RENAULT CLIO CUPS THRUXTON, APRIL 28-29

Porsche scholar Lloyd proves a fast learner

PORSCHE CARRERA CUP
GB rookie Daniel Lloyd delivered an outstanding performance in horrendous conditions at Thruxton to claim his first category race victory, thus becoming the first Porsche scholar to claim a win in his first season in the series.

Starting eighth for the second race of the weekend, Lloyd delivered a stunning first lap – scything his way into the top four through Allard, taking third out of

the complex and passing points leader (and winner of the earlier race) Michael Meadows at Church.

Rory Butcher made a great start from the outside of the front row to lead and he controlled the race well. Lloyd set about trying to get on terms, but after taking too much kerb at the complex, he lost his front splitter – one of several drivers to do so – and his initial challenge faded.

More rain mid-race

changed that, counteracting Lloyd's understeer, and on lap 19 of 21 he was back with Butcher. Side-by-side into the chicane, an attempt by Butcher to outbrake Lloyd resulted in a spin and Lloyd took avoiding action across the chicane.

Although a charging Glynn Geddie (revelling in the tricky conditions) piled on the pressure, the scholar held on. Butcher recovered to third ahead of a splitter-less Meadows.

"After the splitter came off I thought I was done", said Lloyd. "As the track was drying I started to lose touch with Rory, and Michael was catching me again, then it started to spit with rain so the problems didn't matter as much."

In the earlier race, which started under the safety car due to the appalling weather, Richard Plant judged the racing start a little too well and got ahead of poleman Meadows before the green flag. With no penalty forthcoming, Plant built a good lead but faded at mid-distance – suffering with splitter woes.

Meadows took the lead on lap eight and streaked

away before backing off during the closing stages.

Plant lost second on lap 15 to Ben Barker and then slipped to fourth behind Butcher a lap later. Lloyd was fifth, ahead of Pro-Am 1 prince Ahmad Al Harthy.

James Colburn secured his first win of 2012 in a closely contested first race for the Renault Clio Cup, pretty much shadowed throughout by Josh Files.

Starting third on the grid, Colburn made a fantastic launch to slice between Files and first-time polesitter Adam Bonham and he was never headed.

Race two on Sunday began behind the safety car and when the action proper got underway on lap four, poleman Colburn was overcome by Bonham.

However, Bonham and Files both went off at Noble on the second racing lap and through the chaos came reigning champion Rivett to lead, having started fifth.

Following a mid-race safety car period, Rivett came under increasing pressure from Colburn but the win looked secure.

The leader miscalculated the laps though, mistakenly

thinking the penultimate tour was the last of the race, and so a more cautious exit from the chicane enabled Colburn to slice past and steal the win. Jack Goff was third, which added to fourth in race one enabled him to maintain his points lead.

● Marc Orme

RESULTS

Porsche Carrera Cup GB (21 laps)

1 Michael Meadows; 2 Ben Barker +2.751s; 3 Rory Butcher; 4 Richard Plant; 5 Daniel Lloyd; 6 Ahmad Al Harthy. **Class winners** Al Harthy; Tania Mann. **Fastest lap** Barker 1m20.156s (105.81mph).

Race 2 (21 laps) 1 Lloyd;

2 Glynn Geddie +0.582s; 3 Butcher; 4 Meadows; 5 Barker; 6 Jonas Gelzinis. **CW** Al Harthy; Mann. **FL** Sam Tordoff 1m22.736s (102.51mph). **Points** 1 Meadows,

117; 2 Gelzinis, 88; 3 Lloyd, 73; 4 Barker, 73; 5 Tordoff, 67; 6 Plant, 65.

Renault Clio Cup (12 laps) 1 James

Colburn; 2 Josh Files +0.178s; 3 Adam Bonham; 4 Jack Goff; 5 Paul Rivett; 6 James Dixon. **FL** Files 1m24.220s (100.70mph).

Race 2 (15 laps) 1 Colburn;

2 Rivett +1.041s; 3 Goff; 4 Dixon; 5 Kim Andersson; 6 Josh Cook. **FL** Dixon 1m32.114s (92.07mph).

Points 1 Goff, 159; 2 Rivett, 137; 3 Bonham, 130; 4 Dixon, 116; 5 Colburn, 102; 6 Files, 100.



Colburn (2) beat Files for first win of 2012

GINETTA JUNIORS AT A GLANCE

- Race 1 **Charlie Robertson**
- Race 2 **Robertson**
- Points lead **Robertson**

“I thought I’d brought the wrong vehicle - you needed a powerboat out there”

Ingram found conditions tough



REPORTS TOCA THRUXTON

GINETTA BTCC SUPPORTS THRUXTON, APRIL 28-29

Robertson bounces back with double win

CHARLIE ROBERTSON WAS head and shoulders above the opposition during a rain-hit round of Ginetta Juniors at Thruxton, the 15-year-old converting two clear pole positions into a pair of dominant victories.

Despite the challenging conditions at the fastest track on the calendar, the youngest drivers on the BTCC support package provided two largely sedate encounters. This came in stark contrast to the crash-fest that blighted the Donington Park outing a fortnight ago.

Robertson, who arrived at Thruxton fourth in the title race, shot to the top of the table with a double win – his first in the series.

Actually, the podium was identical in both races, with Niall Murray second in each while rookie Harry Woodhead bagged two thirds – his first career rostrums.

“This has been the perfect way to bounce back from the troubles we had at Donington”, said Robertson, “I was praying for rain after qualifying. I knew my wet pace was really good and so rain would be good for us in the races and I think I proved that with two wins

out of two.”

Robertson’s biggest winning margin was in Saturday’s race. He was some 10 seconds clear in an encounter where the Juniors were instructed to use treaded tyres by race officials on the grounds of safety.

So bad did the rain become on Sunday, race two actually started behind the safety car, which enabled Murray to stay closer to the eventual victor.

Woodhead certainly stood out as one of the true stars of the event, winning the rookie cup in each encounter. In race one, he surged through from fifth on the grid into the top three at Allard before passing Murray for second at the complex, although the Irishman retook the place on lap eight of 11.

Although having his winning streak broken at Donington Park by Tom Ingram, normal service was resumed for runaway Ginetta GT Supercup championship leader Tom Sharp at Thruxton with three superb victories.

Saturday’s opener was closely contested at the front, but there was little in the way of exciting action as



Robertson put Donington clash behind him to win twice

Sharp took a controlled lights-to-flag success.

Ingram pressured early on, with Carl Breeze in close company too, but Sharp upped his pace mid-race and eased to victory.

Ingram’s second place came under threat going into the final lap when he got the chicane wrong and lost momentum coming onto the main straight. Breeze tried to pounce but wasn’t quite close enough through Allard.

Incredibly blustery winds and continual rain made for a challenging second race on

Sunday morning and, once again, it was Sharp from Ingram, with Josh Wakefield a fine third. Even better was to come for Wakefield in the finale, where an excellent drive netted him a season-best second.

Sharp took second from Wakefield on lap five and after zeroing in on early leader Ingram he served up an outstanding pass out of the complex into Noble to move ahead on his way to his eighth win from nine race starts.

“I was a little bit hesitant about the pass but, I’ve got to give Tom [Ingram] credit, a lot of drivers would have had both of us off and into the wall there”, said Sharp.

Ingram’s superb run of podium results was unfortunately ended when a driveshaft failure led to an eventual retirement.

Wakefield therefore inherited second, with Breeze a long way back in third. Sharp’s lead in the championship is now a mammoth 115 points.

In the G50 Class Mark Davies boosted his title credentials with two wins and a further podium, while team-mate Louise Richardson put in a superb

drive in the final race to claim her first victory.

● Marc Orme

RESULTS

Ginetta Junior (11 laps)

1 Charlie Robertson; 2 Niall Murray +10.390s; 3 Harry Woodhead; 4 William Palmer; 5 Andrew Watson; 6 Pepe Massot. **Fastest lap** Robertson 1m32.099s (92.09mph).

Race 2 (9 laps) 1 Robertson

2 Murray +2.029s; 3 Woodhead; 4 Ollie Chadwick; 5 Nathan Harrison; 6 Sennan Fielding. **FL** Robertson 1m35.060s (89.22mph).

Points 1 Robertson

144; 2 Murray, 139; 3 Fielding, 134; 4 Watson, 109; 5 Woodhead, 102; 6 Harrison, 92.

Ginetta GT Supercup (11 laps)

1 Tom Sharp; 2 Tom Ingram +1.696s; 3 Carl Breeze; 4 Andrew Richardson; 5 Fergus Walkinshaw; 6 Hunter Abbott. **G50 winner** Mark Davies. **FL** Sharp 1m15.439s (112.42mph).

Race 2 (16 laps)

1 Sharp; 2 Ingram +6.489s; 3 Josh Wakefield; 4 Andrew Richardson; 5 Davies; 6 Louise Richardson. **G50** Davies.

FL Sharp 1m21.730s (103.77mph).

Race 3 (16 laps) 1 Sharp

2 Wakefield +6.839s; 3 Breeze; 4 Abbott; 5 L Richardson; 6 Max Coates. **G50** L Richardson. **FL** Sharp 1m22.832s (102.39mph).

Points 1 Sharp, 310; 2 Ingram, 195; 3 Breeze, 192; 4 Abbott, 152; 5 Wakefield, 138; 6 Colin White, 135.

Sharp sprints away from Supercup field



HOCKENHEIM

GERMANY

April 27-29

DTM

Round 1/10



AT A GLANCE

- Winner **Gary Paffett**
- Pole **Mattias Ekstrom**
- FL **Jamie Green**



Mortara spun Hand, damaged nose



Paffett passed Green after the first stops

Perfect Paffett leads C-coupe superiority

Former champion Gary Paffett led home fellow Brit Jamie Green for an HWA Mercedes one-two in the new-look series

EVERYTHING WAS DIFFERENT at Hockenheim as the DTM's bright new era dawned: 22 all-new thoroughbred racing cars, a new (or rather, returning) manufacturer in BMW and a gaggle of series rookies all eager to make an instant impression.

And yet, come the end of last Sunday's season-opening race, everything was the same: Mercedes dominating on raceday just as it had at the final event of 2011. There was a British winner for the HWA squad

too. Only this time it wasn't Jamie Green, but Gary Paffett, who rediscovered the winning feeling after a disastrous previous campaign that failed to yield a single podium finish.

Recharged after an encouraging winter of testing, Paffett's optimism was clear at Hockenheim, even after he failed to match the pace of the best of the Audi and BMW brigade in qualifying. On the way to his post-session debrief, he sent his good friend Ty Gardner – almost

ever-present at DTM events – a text message with very clear intentions.

"P6. We can win this," it read. How right he was.

From the inside of the third row, he immediately made up a place at the start thanks to BMW's hero of qualifying Dirk Werner making a sluggish getaway from third, and then used his momentum to carry his jet-black C-coupe past Mike Rockenfeller's day-glo Audi for fourth spot.

He made mincemeat of Edoardo Mortara's A5 at



Priaulx took fine sixth in RBM BMW

the tight left-hander at the Mercedes Arena only three laps in and then took only three corners longer than his HWA team-mate Jamie Green to pass Mattias Ekstrom after the polesitter outraked himself at Turn 2 on lap five and slid wide.

So an all-Mercedes fight for victory it was, then, with Ekstrom's Abt Audi dropping back at a consistent 0.3s per lap for the rest of the race; and an all-British battle, too, with former McLaren AUTOSPORT BRDC Award

winners Green and Paffett out on their own.

The crunch point came at the first round of mandatory tyre stops; in-race refuelling having been done away with in favour of a larger fuel tank than on previous-generation cars.

Paffett's stop was 0.4s faster than Green's – about the same distance he'd been behind his friend and rival before the silver C-coupe had stopped two laps earlier – but then he almost stalled before moving back towards the track.

RACE RATING

★★★★☆

Overtaking returned to the DTM in abundance. Long may it continue

MILESTONE

Mercedes scored its 100th one-two finish in the DTM at Hockenheim



REPORT DTM HOCKENHEIM

JAMIE O'LEARY
reports



Tomczyk's (r) race ended shortly after this



That slight delay meant that although Paffett exited ahead, Green's momentum pulled him alongside heading down to Turn 2. And through Turn 2, the left-hand kink that followed, and all down the main straight, the two were just inches apart as they headed towards the tight Spitzkehre and the conclusion of this brief, yet scintillating battle.

"I was on the inside, and I knew that if I just braked at my usual point, then there was no way he could get me," said Paffett afterwards. "It's not the first time we've been like that, but when you do that with someone like Jamie, you know they're not going to make it easy, but they're going to be fair. There's always been a lot of respect between us when we race, and I think that showed there."

From that point on Paffett was unchallenged. Green, who said of the side-by-side battle: "I was comfortable, although maybe Norbert [Haug] wasn't so comfortable watching it," did not have the residual pace to mount an attack and eventually finished 4.7s behind.

Paffett, who had ended 2011 as Mercedes' third driver behind Bruno Spengler and Green, said the win gave him a sense of extra satisfaction.

"Last year I just couldn't get more speed by pushing harder, which was very unusual and maybe to do with how the car worked on the Hankooks," he said. "But that didn't make me a worse driver overnight, and in that situation it's very important not to let it knock your

confidence too much.

"Gerhard [Unger, managing director of HWA] didn't lose faith in me and nor did any of the other guys. They just worked so hard to give me a good car and this is the result. We dominated today, and I thought we might after seeing our long-run pace in the warm-up. So did Eki [Ekstrom] when I spoke to him. He knew what he was up against then, even if the Audis had us in qualifying."

Behind Paffett and Green, HWA debutant Christian Vietoris sealed his best DTM result by coming from 15th to fourth, passing Mike Rockenfeller a couple of laps from the end, while Ralf Schumacher recovered from a drive-through – for spinning Timo Scheider at the Spitzkehre on lap one – to claim seventh.

HWA was smarting after last year's title defeat. It means business. ☘

BMW bruised but unbowed after return



BMW's glorious return in qualifying looked like yesterday's news just a few laps into the race.

Schnitzer man Dirk Werner, third on the grid, started badly and was then turned around early on at the Spitzkehre by Ralf Schumacher; the Mercedes man bashing into the sister M3 of Bruno Spengler as he attempted to avoid the gyrating BM. While Werner dropped to last, the damage to Spengler's car caused his retirement, and the chain reaction that followed led to Adrien Tambay being eliminated too, putting an

end to an impressive weekend for the Frenchman that had resulted in 12th place on the grid and him climbing as high as eighth in the race.

Champion Martin Tomczyk lasted little longer, a brush with Roberto Merhi's Mercedes at the exit of the Nordkurve damaging the RMG car beyond repair, but at least there was one standout performance for the manufacturer as RBM's Andy Priaulx held firm for sixth – just 0.5s behind Mike Rockenfeller's Audi – after a sterling drive from the British debutant that had began from seventh on the grid.

David Coulthard looked set for his best DTM result, but the Mucke Mercedes driver was passed for seventh at the hairpin in the dying laps by his former F1 rival Schumacher, who was recovering from an earlier drive-through that he accrued for spinning Timo Scheider at the Spitzkehre on the opening lap.

While recovering Scheider spun again, this time thanks to contact with Merhi, and by that point the former double champion had had enough. The damage to his Abt A5 was slowing the car and led to him calling it a day before the halfway point.



The pack was tight behind the leaders on lap one

RESULTS

DTM, round 1 of 10, Hockenheim (D), April 29

GRID	
1 EKSTROM 1:34.690	2 GREEN 1:34.895
3 WERNER 1:36.276*	4 MORTARA no time*
5 R'FELLER 1:34.264	6 PAFFETT 1:34.287
7 PRIAULX 1:34.299	8 SCHEIDER 1:34.389
9 SPENGLER 1:34.512	10 TOMCZYK 1:34.819
11 SCHUMACHER 1:34.390	12 TAMBAY 1:34.509
13 WICKENS 1:34.538	14 A'QUERQUE 1:34.555
15 VIETORIS 1:34.783	16 HAND 1:35.140
17 MOLINA 1:34.926	18 COULTHARD 1:34.932
19 FARFUS 1:35.104	20 MERHI 1:35.167
21 WOLFF 1:35.776	22 FREY 1:36.012

40 LAPS, 113.686 MILES

POS	DRIVER (NATIONALITY)	TEAM	CAR	RESULT	GRID
1	Gary Paffett (GB)	HWA	Mercedes C-coupe	1h04m37.615s	6
2	Jamie Green (GB)	HWA	Mercedes C-coupe	+4.709s	2
3	Mattias Ekstrom (S)	Abt Sportsline	Audi A5	+19.434s	1
4	Christian Vietoris (D)	HWA	Mercedes C-coupe	+25.774s	15
5	Mike Rockenfeller (D)	Phoenix Racing	Audi A5	+27.834s	5
6	Andy Priaulx (GB)	RBM	BMW M3	+28.435s	7
7	Ralf Schumacher (D)	HWA	Mercedes C-coupe	+39.948s	11
8	David Coulthard (GB)	Mucke Motorsport	Mercedes C-coupe	+43.306s	18
9	Miguel Molina (E)	Phoenix Racing	Audi A5	+46.079s	17
10	Filipe Albuquerque (P)	Team Rosberg	Audi A5	+46.614s	14
11	Edoardo Mortara (I)	Team Rosberg	Audi A5	+47.253s	4
12	Susie Wolff (GB)	Persson Motorsport	Mercedes C-coupe	+51.971s	21
13	Joey Hand (USA)	RMG	BMW M3	+1m08.628s	16
14	Robert Wickens (CDN)	Mucke Motorsport	Mercedes C-coupe	+1m09.027s	13
15	Augusto Farfus (BR)	RBM	BMW M3	+1m09.556s	19
16	Rahel Frey (CH)	Abt Sportsline	Audi A5	+1m16.123s	22
17	Dirk Werner (D)	Schnitzer Motorsport	BMW M3	-1 lap	3
18	Roberto Merhi (E)	Persson Motorsport	Mercedes C-coupe	38 laps-acc damage	20
R	Timo Scheider (D)	Abt Sportsline	Audi A5	13 laps-acc damage	8
R	Martin Tomczyk (D)	RMG	BMW M3	4 laps-acc damage	10
R	Adrien Tambay (F)	Abt Sportsline	Audi A5	3 laps-acc damage	12
R	Bruno Spengler (CDN)	Schnitzer Motorsport	BMW M3	3 laps-acc damage	9

CHAMPIONSHIP TABLE

POS	DRIVER	PTS
1	Paffett	25
2	Green	18
3	Ekstrom	15
4	Vietoris	12
5	Rockenfeller	10
6	Priaulx	8
7	Schumacher	6
8	Coulthard	4
9	Molina	2
10	Albuquerque	1

* denotes Q4 time deleted.
Winner's average: 105.547mph.
Fastest lap: Green, 1m34.901s, 107.815mph.

SAO PAULO

BRAZIL

April 28-29
IndyCar Series
Round 4/16

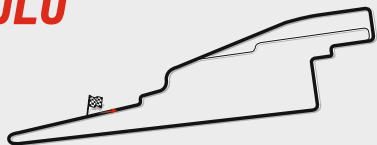

AT A GLANCE

- Winner Will Power
- Pole Will Power
- Most laps led Will Power
- Fastest lap Josef Newgarden



Beatriz returned with Andretti

Will to the Power of three

The Penske star kept out of trouble to record a 2012 hat-trick



THERE IS A SAYING AMONG the US racing fraternity that cautions breed cautions. IndyCar had enjoyed a largely incident-free start to the 2012 season up until last weekend, despite the proliferation of normally high-attrition street courses over the opening rounds, but 15 chaotic minutes at Sao Paulo on Sunday resulted in three restarts and a race turned entirely on its head.

Only Penske's Will Power seemed immune to the mayhem, the Australian completing a hat-trick of

Brazil victories after starting from pole. But right through the field, it was a race from which no-one emerged without a story to tell, and most centred around the ramifications of a string of three yellow-flag periods a third of the way into the race, and another pair of cautions 15 laps before the finish. Clean restarts were not the order of the day.

None of Power's wins has been straightforward this year. He won from ninth on the grid at Barber, from 12th in the field at Long Beach, and even

though he headed the grid this time out, he still had his hands full. Another Ganassi implosion had left Andretti's Ryan Hunter-Reay as his main threat in the closing phase of the race, and Power admitted that the late restarts were something that he could have done without.

"I was giving it absolutely everything to keep Ryan behind me," he said. "I knew I had to pull some sort of gap, because if I'd kept him in my tow, he'd definitely have passed me."

Hunter-Reay was just about a match for Power in

Sao Paulo streets led to plenty of contact



RACE RATING

★★★★☆

Needed the cautions to keep it interesting, but they did their job

MILESTONE

First time Roger Penske's cars have won the first four races of any series



REPORT INDYCAR SAO PAULO

MARK GLENENNING
reports



Hunter-Reay took another podium slot



Power leads at a restart as Franchitti gets spun around

terms of pure speed over the closing laps, but he wasn't able to use it.

"[Power] was just so strong out of the corners, especially Turn 4 and 10 where you set up the passing," he said. But his second place was another good result for a driver who admits that he's playing the long game.

It was just behind him where things started to get weird, with Rahal Letterman Lanigan's Takuma Sato taking his first IndyCar podium with third. The result had been coming — he briefly led

a couple of races ago — but on this weekend, it's fair to say that it hadn't been written in the stars (see sidebar).

Sato's success had come partly at the expense of Dario Franchitti, whom he passed on one of the final restarts. But like Sato, the reigning champion had no business being that far up the field in the first place. After a poor start to the year, the Scot had been enjoying a return to form during the opening phase of the weekend, and was running in second ahead of team-mate Scott Dixon

early on in the race.

Things turned sour just after his first stop, which came a couple of laps before Penske's Ryan Briscoe hit the wall and brought out the first safety car. The timing of the yellows meant that Franchitti was in traffic for the restart, which meant that he was exposed to being on the receiving end of a hit that sent him bouncing backwards over the kerbs at Turn 1. With most of the field still bearing down on him it could have been a lot worse, but as it was, he was left in 23rd and grateful to still be on the lead lap.

What followed was as good a Lazarus trick as you'll see. Franchitti improved his position with a few passing moves, had a bit of additional help when Josef Newgarden was turned around by Simona de Silvestro and created a bottleneck, and less than 10 laps after his afternoon had seemingly fallen apart, he was back in the top 10.

A combination of overtaking and the strategies of the drivers around him helped him continue to climb back up the order, and he made it as high as third before he began to struggle to keep heat in his tyres in the last couple of restarts and was picked off by Sato and Helio Castroneves.

Dixon on the other hand, was again left to feel the wrath of whichever deity it is that he has apparently managed to offend. At Barber a couple of races ago, he lost a probably victory to a bad pitstop. This ▶

Sato takes starring role on Sao Paulo streets



Sato starred from back

By any standards, Takuma Sato's weekend didn't get off to the most auspicious of starts. Arriving in Brazil having not completed a full race yet this season (he retired at St Petersburg and Barber, and finished a lap down at Long Beach), the start to his Brazil adventure gave little indication that things would turn around. His practice time was cut short, first by a suspected gearbox problem, and then by an engine hiccup that required the unit to be changed. The tight two-day format of the weekend meant that it was impossible for the team to finish the job before qualifying, resulting in him missing the session and being put to the back of the grid (a scenario that rendered the 10-place grid penalty for making an engine change rather academic). Speaking on Saturday, he was under no illusions about his predicament.

"Realistically, if it's dry,

it will be very difficult to get a top result," he said. "But nothing is impossible."

From there he achieved the unusual distinction of being issued a drive-through penalty in the Sunday morning warm-up for hitting Tony Kanaan's car, and then was penalised again during the race for pitlane speeding and narrowly avoided being lapped. Yet amazingly he was able to recover to third, partly because the yellows worked for him in precisely the same way that they worked against almost everyone else, and partly through a nice overtaking move on Dario Franchitti late in the race.

"There wasn't a strategy, to be honest," he said. "We just need to move up positions. I was just hanging on until the yellows came, and that's what helped me. We didn't have the same speed [as Power and Hunter-Reay] but we came back in the race. That was a very, very strong recovery."



L to r: Sato, Hunter-Reay and Power do their podium thing

REPORT INDYCAR SAO PAULO



Hinchcliffe took P6 for Andretti

“When I saw Dario after the race, I stopped to ask him when you have to spin so that you can come in and take fuel” Rubens Barrichello



Newgarden faces traffic but recovered to set fastest lap



Barrichello enjoyed himself

updates had made a difference, although exactly what that translates into was less clear. The Honda was quicker through the speed trap, which some of the Chevrolet runners were convinced could be attributed to the changes.

time, he managed to overtake Power and set about trying to build a gap, knowing that he, unlike his rival, needed to have his fuel topped up to get to the finish. But that campaign ended when he became one of several drivers to get trapped when Mike Conway was squeezed into the Turn 2 wall on a restart, dropping the New Zealander to the back of the field. Unlike Franchitti, he did not have enough laps left to recover.

There were a few shining lights elsewhere in the field. KV Racing's entire line-up

drove well, although the timing of the yellows cost them several positions towards the end of the race. Nevertheless, both EJ Viso and Rubens Barrichello managed to finish in the top 10, while Tony Kanaan came home in 13th.

Ed Carpenter's performance was also worth a mention. Little was expected from the new, single-car owner-driver team this year, especially when the driver in question is an admitted oval specialist and the season started with four road/

street courses. But the Ed Carpenter Racing entry showed signs of genuine progress this weekend, and at times was running in the top 10 before being derailed by an array of misfortunes that ranged from being hit, to having the starter break on the safety truck.

“I wish we could have gotten the result that we were working on,” Carpenter said. “But it's getting there. The team is doing a good job. It's hard with a new group, and I definitely need to be better on road courses, but it's

coming together.”

Aside from two-thirds of the field apparently forgetting how to handle restarts, the talking point of the weekend was the arrival of the upgraded turbo units on the Honda-powered cars, which were the result of a parity-based concession granted by the series. (And one that was met with ferocious objection from Chevrolet).

There was a consensus across the field that the

Ed Carpenter defied his one-car, owner/driver status



Ed Carpenter defied his one-car, owner/driver status

RESULTS

IndyCar Series, round 4 of 16, Sao Paulo (BR), April 28-29

GRID	
1 POWER 1:21.4045	2 FRANCHITTI 1:21.4485
3 DIXON 1:21.8545	4 HINCHCLIFFE 1:21.9956
5 HUNTER-REAY 1:22.2408	6 RAHAL 1:21.8033
7 CONWAY 1:21.8122	8 NEWGARDEN 1:21.8128
9 BRISCOE 1:21.8495	10 ANDRETTI 1:21.8498
11 KANAAN 1:22.5210	12 BARRICHELLO 1:22.3939
13 VISO 1:22.1404	14 HILDEBRAND 1:22.4321
15 KIMBALL 1:22.1973	16 PAGENAUD 1:22.4354
17 JAKES 1:22.3840	18 BOURDAIS 1:23.1331
19 C'NEVES 1:22.4143	20 BEATRIZ 1:23.2692
21 CARPENTER 1:22.9424	22 SILVESTRO 1:23.6762
23 SERVIA 1:23.4509	24 LEGGE 1:24.6042
25 SATO no time	26 WILSON 1:21.7386*

75 LAPS, 190, 200 MILES				
POS	DRIVER (NATIONALITY)	TEAM	CAR	TIME
1	Will Power (AUS)	Team Penske	Dallara-Chevrolet DW12	2h08m18.2816s
2	Ryan Hunter-Reay (USA)	Andretti Autosport	Dallara-Chevrolet DW12	+0.9045s
3	Takuma Sato (J)	Rahal Letterman Lanigan Racing	Dallara-Honda DW12	+2.3905s
4	Helio Castroneves (BR)	Team Penske	Dallara-Chevrolet DW12	+4.5489s
5	Dario Franchitti (GB)	Chip Ganassi Racing	Dallara-Honda DW12	+5.1722s
6	James Hinchcliffe (CDN)	Andretti Autosport	Dallara-Chevrolet DW12	+6.2615s
7	JR Hildebrand (USA)	Panther Racing	Dallara-Chevrolet DW12	+8.3764s
8	Charlie Kimball (USA)	Chip Ganassi Racing	Dallara-Honda DW12	+8.5905s
9	EJ Viso (YV)	KV Racing Technology	Dallara-Chevrolet DW12	+10.3449s
10	Rubens Barrichello (BR)	KV Racing Technology	Dallara-Chevrolet DW12	+10.8477s
11	Oriol Servia (E)	Dreyer & Reinbold Racing	Dallara-Lotus DW12	+24.4771s
12	Simon Pagenaud (F)	Schmidt-Hamilton Motorsports	Dallara-Honda DW12	-1 lap
13	Tony Kanaan (BR)	KV Racing Technology	Dallara-Chevrolet DW12	-1 lap
14	Marco Andretti (USA)	Andretti Autosport	Dallara-Chevrolet DW12	-1 lap
15	James Jakes (GB)	Dale Coyne Racing	Dallara-Honda DW12	-1 lap
16	Graham Rahal (USA)	Chip Ganassi Racing	Dallara-Honda DW12	-1 lap
17	Scott Dixon (NZ)	Chip Ganassi Racing	Dallara-Honda DW12	-1 lap
18	Sebastien Bourdais (F)	Dragon Racing	Dallara-Lotus DW12	-1 lap
19	Mike Conway (GB)	AJ Foyt Racing	Dallara-Honda DW12	-2 laps
20	Ana Beatriz (BR)	Andretti Autosport	Dallara-Chevrolet DW12	-2 laps
21	Ed Carpenter (USA)	Ed Carpenter Racing	Dallara-Chevrolet DW12	-3 laps
22	Justin Wilson (GB)	Dale Coyne Racing	Dallara-Honda DW12	66 laps-gearbox
23	Josef Newgarden (USA)	Sarah Fisher Hartman Racing	Dallara-Honda DW12	61 laps-accident
24	Simona de Silvestro (CH)	HVM Racing	Dallara-Lotus DW12	28 laps-accident
25	Ryan Briscoe (AUS)	Team Penske	Dallara-Chevrolet DW12	21 laps-accident
26	Katherine Legge (GB)	Dragon Racing	Dallara-Lotus DW12	20 laps-accident

CHAMPIONSHIP TABLE		
POS	DRIVER	PTS
1	Power	180
2	Castroneves	135
3	Hinchcliffe	123
4	Hunter-Reay	121
5	Pagenaud	118
6	Dixon	109
7	Sato	83
8	Briscoe	83
9	Hildebrand	83
10	Franchitti	82

Winner's average: 88.945mph.
Fastest lap: Newgarden, 1m22.6313s, 110.486mph.
Qualifying: field divided into two groups for qualifying. The fastest six from each move into a 12-car second round. The fastest six from this move into the pole shootout.
*times disallowed



Find out what you'll really get to the gallon

Use our online tool to get your personalised MPG figure based on our exclusive real-world tests, on UK roads

Get your **True MPG** at whatcar.com/truempg



TOYOTA MOTORSPORT GMBH

THE HOME OF HIGH PERFORMANCE

The world of motorsport is a 24-hour-a-day job, seven days a week, all year round, which is why the TOYOTA Racing team relies on the proven expertise of TOYOTA Motorsport GmbH and its state-of-the-art facilities in Cologne, Germany.

TMG's 30,000m² centre of excellence offers advanced engineering services, providing an invaluable resource to accelerate development cycles and deliver greater performance. Seven key disciplines covering all areas of vehicle development make TMG a unique one-stop shop for companies looking to gain an advantage against the competition.

To access TMG's Home of High Performance, please visit www.toyota-motorsport.com or email contact@toyota-motorsport.com



1 UNIQUE FACILITY 7 KEY DISCIPLINES 24 HOURS

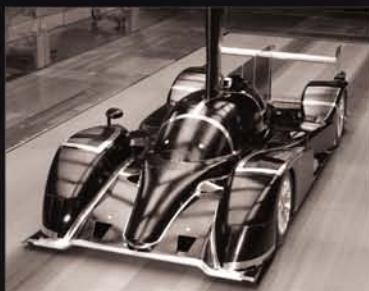

- EXTENSIVE AND UNIQUE TESTING RIGS
- CALCULATION AND SIMULATION
- CAR DESIGN AND DEVELOPMENT
- ENGINE DESIGN AND DEVELOPMENT
- ELECTRIC VEHICLE DEVELOPMENT
- DRIVING SIMULATOR
- MANUFACTURING

www.toyota-motorsport.com

Coil-Over Spring Rater

Check Coil Bind, Bump Stops & Rod Pressure



Height of 31" (787mm) Eye to Eye

Rate Standard Coil Springs 2.5" (64mm) to 6" (152mm) Diameter

10 5/8" (270mm) Jack Travel with 12" (305mm) Digital Travel Indicator



Easy to Use Handles Allow for Adjustments without Tools

NEW!

Coil-Over Spring Rater

Capacity: 5,000lb (2,500kg)
Part # 110060

Optional Pull Bar Rater
Part # 110064



Want to learn more?
Use your smart phone to scan this code or visit us online at www.intercompracing.com

Intercomp offers the most comprehensive line of indicators

Intercomp's industry leading RFX™ Wireless Weighing Technology is the most widely used advanced weighing technology of it's kind and is used by champions in all forms of motorsports.

Euro Cross Weights Shown!



SW787™
PC Wireless Scale System

(PC Not Included)
Part # 170154-PC



SW650RFX™
Wireless Scale System
Part # 170126-W



SW777RFX™
Wireless Scale System
Part # 170127-WPC



SW500™
Cabled Scale System
Part # 170125

Intercomp
advanced weighing technology... by any measure

Call to request our 2012 Racing Products Catalog or log on to:

intercompracing.com



NEW!
Intercomp Scale App for iPhone®

+44 (0) 118 932 0578 EUROPE

USA +1 763-476-2531

European Sales & Service

DEMON TWEAKS
Wrexham, Clwyd

ROLLECENTRE RACING
St. Ives, Cambs

RACE HARDWARE
The Netherlands

DANIELSON
Magny-Cours, France

GIEFFE SRL
Castelceriolo, (AL) Italia

ISA RACING
Kottenheim, Germany

NIMEX
Monheim, Germany

Tel: 44(0) 1978 664466
Fax: 44(0) 1978 664467

Tel: 44(0) 1480 464052
Fax: 44(0) 1480 461454

Tel: 30(0) 36 537 0689
Fax: 30(0) 36 537 1797

Tel: 33(0) 3 86 21 22 55
Fax: 33(0) 3 86 21 22 65

Tel: 39(0) 131 216505
Fax: 39(0) 131 216506

Tel: 49(0) 2651 96250
Fax: 49(0) 2651 962510

Tel: 49(0) 2173 54253
Fax: 49(0) 2173 51089

SAKHIR

BAHRAIN

April 27-28

GP2

Round 3/12

**RACE RATING**

★★★★☆

Great fights throughout and nearly a record-breaking performance

REPORT
GP2 SAKHIR

GP2 SERIES SAKHIR (BRN), APRIL 27-28

Valsecchi is the new crown prince of Bahrain



Leimer (5) could not stop Valsecchi (3)

NO DRIVER HAS EVER WON

four GP2 races in a row, but during the series' standalone meeting at Sakhir in Bahrain Davide Valsecchi came within touching distance of making history.

The DAMS driver was the class of the field in the Formula 1 support races the previous weekend, but he was pipped to pole position by Caterham's Giedo van der Garde. The Dutchman converted pole into the lead, but as had been the case a week before, Valsecchi was

able to use his Pirelli tyres much more effectively and, as the race wore on, his advantage increased and van der Garde was powerless to fend off his charge.

Racing Engineering's Fabio Leimer soon followed Valsecchi by van der Garde, but the Swiss could do nothing to stop Valsecchi reeling off his third win in less than a week.

The reversed-grid rule ensured the Italian would start eighth for his record-breaking attempt, and his

chances were hurt when van der Garde was punted into a spin by fast-starting Lotus driver Esteban Gutierrez at the first corner and the championship leader had to take evasive action.

His next issue was Marcus Ericsson. The Swedish driver made an amazing start in race one to vault from ninth to fourth, but his iSport car was chewing up its rear tyres and he dropped through the order to eighth (which became seventh when DAMS' Felipe Nasr was penalised for ignoring a yellow flag).

Again Ericsson struggled for pace, but he was sufficiently good at exiting the corners to prevent Valsecchi from pulling off a move. As he was bunched up behind Ericsson, Tom Dillmann was making hay.

The Rapax driver had inherited pole and made a great start to lead. For lap after lap he extended his

advantage, but with half-a-dozen laps to go, Arden's Luiz Razia (fourth in race one) started to close in. At first it was by tenths, then whole seconds. Coming on to the final lap there was nothing in it, but Dillmann kept his head to score his first GP2 victory.

Meanwhile Valsecchi worked his way by Carlin's Rio Haryanto (a strong sixth in race one) and Gutierrez to take third. At one stage he'd been more than 10 seconds off the lead, but he scythed into the gap, which was down to 2.9s by the flag.

Nasr recovered from his penalty to fight his way into fifth, ahead of Haryanto, Ericsson and Leimer.

It was a frustrating weekend for the Brits. Max Chilton went well for Carlin in race one to finish fifth, but had a scrappy sprint and fell to 13th. Lotus decided not to run James Calado in free practice to save tyres and

it backfired. He started from the pits after a problem on the grid and finished 17th. Things weren't much better in race two where he finished 12th. iSport driver Jolyon Palmer retired from the feature and had a problem on the grid in the sprint, but set the fastest lap on his way to 22nd. Unfortunately, as he was outside the top 10 he didn't collect the bonus point to go with it.

RESULTS

Race 1 Davide Valsecchi, 32 laps in 57m35.088s; 2 Fabio Leimer, +7.711s; 3 Giedo van der Garde; 4 Luiz Razia; 5 Max Chilton; 6 Rio Haryanto; 7 Marcus Ericsson; 8 Tom Dillmann; 9 Johnny Cecotto Jr; 10 Esteban Gutierrez. **Race 2** 1 Dillmann, 23 laps in 41m16.276s; 2 Razia +0.198s; 3 Valsecchi; 4 Gutierrez; 5 Felipe Nasr; 6 Haryanto; 7 Ericsson; 8 Leimer; 9 Fabio Onidi; 10 Nathanael Berthon. **Points** 1 Valsecchi, 107; 2 Razia, 83; 3 Gutierrez, 54; 4 Chilton, 45; 5 Leimer, 41; 6 James Calado, 39.

Dillmann took race-two win



SLOVAKIA RING

SLOVAKIA

April 28-29

WTCC

Round 4/12

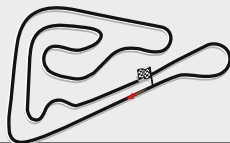

AT A GLANCE

- Race 1 **Gabriele Tarquini**
- Race 2 **Rob Huff**
- Pole **Norbert Michelisz**
- Points leader **Yvan Muller**



Tarquini took first win for just over a year

SEAT stalls Chevy's charge

Veteran Gabriele Tarquini led a Lukoil SEAT Leon one-two to finally break Chevrolet's six-race stranglehold on 2012



Barely a Chevy in sight for race 1 start

ASIDE FROM A BLIND DATE with a mystery circuit, there were two key topics of intrigue for the World Touring Car Championship circus as it headed to the Slovakia Ring, located among a vibrant backdrop of rapeseed fields east of Bratislava. Could the new venue, a late addition to the series' calendar in place of Argentina, expedite a surprise result and end the factory RML Chevrolets' unbeaten run of races?

If not, the need for Briton Rob Huff to kick-start his championship assault with a win was arguably greater than ever. Huff's status as the Wellingborough-based team's perennial bridesmaid this season was unenviable, and a top result was overdue.

The likelihood of either event materialising

remained clouded after practice. A 'hire-car grand prix' was the only track activity on Friday. Prior to qualifying, drivers were restricted to two half-hour sessions in which to acclimatise to Austrian designer Hans Roth's six kilometre lay-out. Three artificial 'jumps' apart, the circuit was swiftly likened to Brno and Valencia –

Muller saved this R2 assault from Tarquini



traditional BMW territory.

Fierce heat and an abundance of constant-radius corners triggered alarm bells at RML over potential tyre wear, and ensured the limited track time was focused on race set-up development. The result: the worst collective qualifying effort in almost two years for 2012's dominant three-car team.

Lukoil Racing's Gabriele Tarquini was the most obvious candidate to take advantage of Chevrolet's struggles, but the Italian veteran could only muster third on a shock race-one grid. Instead, Yokohama Independent Norbert Michelisz produced a stunning maiden pole in his Zengo Motorsport BMW (see sidebar).

Completing a curious front row was the second Lukoil SEAT WTCC entry of Aleksei Dudukalo. The unassuming Russian ice-racing champion was taken aback to see his portrait adorned on buses in Bratislava, as part of the meeting's heavy local promotion. Dudukalo confessed to being almost equally shocked to back up the lofty billing by out-

qualifying mentor Tarquini in a stellar performance.

Also threatening the sharp end were Team Aon's Fords; the lightest cars at Slovakia following the imposition of all-new, road-car rear suspension. But after qualifying fourth, James Nash's Focus S2000 failed a ride-height test and landed a 10-place grid-drop.

Tarquini executed a superb start to challenge Michelisz's lead into Turn 1.

"It was the first race this year with no blue cars around me, so it was important that I took my chance," said the Italian. Keen to overtake the rear-wheel-drive BMW before it could take advantage of expected superior tyre wear late in the race, Tarquini forced the issue on lap three.

RACE RATING

★★★★☆

Well-supported addition to championship thrilled fans with two new 2012 winners

MILESTONE

Huff's race-one retirement his first since Marrakech in April 2010



REPORT WTCC SLOVAKIA RING

PETER MILLS
reports



Arriving hot at the downhill braking for Turn 3, Tarquini gave Michelisz a healthy shove off the racing line to grab the lead. "I had just gone over the bump with the front wheels in the air, so when I hit the brakes I locked up," he explained.

Quick reactions from Dudukalo helped the Russian snatch second place, and further bullying was in store for the recovering Michelisz on the following tour. An overoptimistic manoeuvre from points leader Yvan Muller sent the orange-and-black BMW spinning out of third place, and the triple world champion received a drive-through for his error.

Dudukalo was unable to keep pace with Tarquini, and on lap six had a lapse and ran off road at the final corner. Pepe Oriola snapped up second position in his similar Leon, but the Tuenti Racing man cruelly stopped with a puncture three laps shy from achieving his highest WTCC finish.

Oriola's misfortune restored a Lukoil Racing one-two. Both men deserved a change of fortune after enduring torrid recent reliability with the new ORECA-tuned, Skoda-sourced Leon WTCC. For Tarquini it was his first

Huff was relieved to end '12 win drought



win since Zolder in 2011.

Third for Alain Menu lifted the Swiss to within nine points of RML team-mate Muller in the title race. First-lap incidents accounted for Huff and Nash; the latter finding the gravel after being tagged by Oriola's team-mate Tiago Monteiro. "The gravel was so thick it tore all the brake pipes off," said Nash, "but I didn't know that until the next corner. So I was flat out in fourth gear when I hit the brakes – and got nothing."

Nash non-started race two owing to heavy rear damage, and Huff almost joined his compatriot on the bench after being wiped out in someone else's accident.

"The team did the most amazing job to get the car straight for race two," said Huff. "They had to change the front suspension, and panel the car on both sides to make

sure it was straight. Both rear wheels were pointing in opposite directions."

From fourth, Huff made his "best ever" start to pass poleman Stefano d'Aste into the lead on the exit of Turn 2. Menu attempted to follow his team-mate past the Tricolore-liveried Wiecher-Sport car at Turn 3, only to clip d'Aste and pick up a race-ending puncture.

Huff blanked out his pre-race dramas to record a masterly victory. In his mirrors, a fraught last-lap duel unfolded for the runner-up position. Tarquini was involved in his second controversial incident of the day by clouting Muller into a half-spin. Ice-racing honed car control helped Muller conjure a remarkable save, and take a 26-point lead over Huff into round five at the Hungaroring this weekend. ❧

Maiden meeting adds clout to racing's future

It was tough to gauge how many locals elected to skip ice hockey matches in the shopping malls of Bratislava last Sunday and journey to the Slovakia Ring. The amazing qualifying effort of Norbert Michelisz, reigning Sportsman of the Year in neighbouring Hungary, was perhaps an influence in the estimated 30,000 weekend attendance – an impressive feat for the circuit's first WTCC meeting. "It is sometimes a little bit of a problem for us that the government is not more

involved," said the Slovakia Ring's sales manager Katarina Jankovicsova. "In Slovakia, football and ice hockey have strong government support."

Whether it was a sudden interest in motorsport, the scorching temperatures or the anticipated presence of Miss World, the President of the Republic elected to put in an appearance at the weekend. Given the success of the meeting, Jankovicsova can perhaps be allowed to hope for more fruitful dealings with her country's sporting bodies in future.



Hungarian fans came to support Michelisz

RESULTS

FIA World Touring Car Championship, round 4 of 12, Slovakia Ring (SK), April 29

GRID RACE 1	
2 DUDUKALO 2:13.076	1 MICHELISZ 2:12.990
4 MONTEIRO 2:13.322	3 TARQUINI 2:13.137
6 HUFF 2:13.575	5 MULLER 2:13.366
8 MENU 2:13.721	7 ORIOLA 2:13.684
10 CHILTON 2:14.766	9 D'ASTE 2:14.668
12 CORONEL 2:14.490	11 CERQUI 2:15.288
14 NASH 2:13.317*	13 ENGSTLER 2:14.676
16 MACDOWALL 2:15.039	15 O'YOUNG 2:14.856
18 NG 2:16.129	17 SABATINO 2:15.756
20 BENNANI 2:14.823**	19 WEBER 2:16.536
21 BOARDMAN no time	

RACE 1 - 10 LAPS, 36.80 MILES					
POS	DRIVER (NATIONALITY)	TEAM	CAR	TIME	GRID
1	Gabriele Tarquini (I)	Lukoil Racing	SEAT Leon WTCC	22m42.275s	3
2	Aleksei Dudukalo (RUS)	Lukoil Racing	SEAT Leon WTCC	+2.484s	2
3	Alain Menu (CH)	Chevrolet (RML)	Chevrolet Cruze 1.6T	+4.194s	8
4	Alberto Cerqui (I)	ROAL Motorsport	BMW 320 TC	+6.992s	11
5	Stefano d'Aste (I)	Wiechers-Sport	BMW 320 TC	+7.978s	9
6	Norbert Michelisz (H)	Zengo Motorsport	BMW 320 TC	+9.943s	1
7	Darryl O'Young (PRC)	Special Tuning Racing	SEAT Leon WTCC	+11.164s	15
8	Tom Boardman (GB)	Special Tuning Racing	SEAT Leon TDI	+20.643s	21
9	Gabor Weber (H)	Zengo Motorsport	BMW 320 TC	+20.961s	19
10	Yvan Muller (F)	Chevrolet (RML)	Chevrolet Cruze 1.6T	+21.174s	5
11	Mehdi Bennani (MA)	Proteam Racing	BMW 320 TC	+21.787s	20
12	Alex MacDowall (GB)	Bamboo-Engineering	Chevrolet Cruze 1.6T	+22.676s	16
13	Pasquale di Sabatino (I)	Bamboo-Engineering	Chevrolet Cruze 1.6T	+31.153s	17
14	Tom Coronel (NL)	ROAL Motorsport	BMW 320 TC	+41.395s***	12
15	Charles Ng (PRC)	Team Engstler	BMW 320 TC	+1m42.394s	18
16	Pepe Oriola (E)	SUNRED Engineering	SEAT Leon WTCC	7 laps-puncture	7
R	Rob Huff (GB)	Chevrolet (RML)	Chevrolet Cruze 1.6T	7 laps-damage	6
R	Franz Engstler (D)	Team Engstler	BMW 320 TC	5 laps-accident	13
R	Tiago Monteiro (P)	SUNRED Engineering	SEAT Leon 1.6T	1 lap-accident	4
R	Tom Chilton (GB)	Arena Motorsport	Ford Focus S2000 TC	0 laps-accident	10
R	James Nash (GB)	Arena Motorsport	Ford Focus S2000 TC	0 laps-accident	14

RACE 2 - 10 LAPS, 36.80 MILES			
POS	DRIVER	TIME	GRID
1	Huff	22m38.101s	4
2	Muller	+2.029s	5
3	Tarquini	+2.555s	7
4	Coronel	+8.859s	12
5	Oriola	+9.352s	3
6	Michelisz	+9.553s	9
7	Bennani	+11.675s	13
8	Cerqui	+12.773s	11
9	O'Young	+14.161s	14
10	Chilton	+20.847s	10
11	Boardman	+30.073s	17
12	di Sabatino	+30.617s	16
13	Engstler	+30.964s	18
14	d'Aste	+32.757s	1
15	Dudukalo	+41.317s	8
R	Monteiro	6 laps-engine	6
R	Menu	3 laps-puncture	2
R	MacDowall	2 laps-acc damage	15
R	Weber	1 lap-accident	20
NS	Ng	Acc damage race 1	19
NS	Nash	Acc damage race 1	17

CHAMPIONSHIP TABLE		
POS	DRIVER	PTS
1	Muller	149
2	Huff	122
3	Menu	121
4	Coronel	89
5	Tarquini	87
6	d'Aste	55
7	Oriola	53
8	Michelisz	47
9	Engstler	34
10	Dudukalo	22

INDEPENDENTS		
POS	DRIVER	PTS
1	Oriola	62
2	d'Aste	53
3	Michelisz	47

MANUFACTURERS		
POS	MANUFACTURER	PTS
1	Chevrolet	337
2	SEAT Customer	219
3	BMW Customer	208

Race 1 Winner's average: 97.05mph. Fastest lap: Michelisz, 2m14.606s, 98.41mph. Race 2 Winner's average: 97.34mph. Fastest lap: Muller, 2m14.508s, 98.48mph. *10-place grid penalty, **5-place grid penalty, ***30s added to race time.

ALGARVE

PORTUGAL

April 28-29

Formula 2

Round 2/8

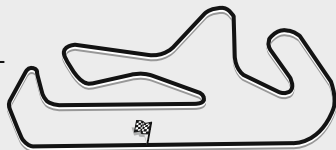

AT A GLANCE

- Race 1 Luciano Bacheta
- Race 2 Luciano Bacheta
- Poles Bacheta/Tuscher
- Fastest laps Tuscher/Bacheta



Tuscher was second twice

Bacheta chased by 15-year-old

Lanky young Brit takes another double in Portugal - but he has a pesky Swiss schoolboy to keep him on his toes throughout the weekend



Tuscher managed to lead Bacheta in race two

ALTHOUGH LUCIANO BACHETA won both races at the Algarve to continue his 100 per cent record in Formula 2 this year, the star of the weekend was arguably 15-year-old Swiss driver Matheo Tuscher.

Despite his age, Tuscher – who won the Formula Pilota (Abarth) title in China last year – holds the required FIA international licence to compete in F2. He took pole position for the opening round of the season at Silverstone, but dropped back in the races to fifth and sixth, making a couple of errors along the way.

Calling that pole a fluke might have been harsh, but there were many who felt it unlikely to be repeated.

Such perceptions were shattered in first qualifying

in Portugal. Tuscher was there again, third on the grid behind Bacheta and German Markus Pommer. Not only that, but here is a schoolboy whose mastery of English is exemplary, and who answers questions more succinctly and expressively than a lot of his British counterparts.

The 500bhp F2 machines are certainly a step up from the Formula Pilota cars he raced last year, in his first season of car racing, and that was evident at Silverstone as he struggled to control the power off the line. But he had no such problems in Portugal, getting a perfect start from third on the grid in race one to challenge leader Bacheta at the first corner.

And so began a 22-lap battle of wits. Tuscher was

a second behind Bacheta for the majority of the race, biding his time before launching an attack in the final few laps. Essex lad Bacheta, a talented youngster himself with a more-than-impressive single-seater record, was surprised at Tuscher's pace.

"Once I got the lead, I was planning to control the gap and save the tyres" he said. "But Matheo just kept coming and I ended up doing everything I could

to pull away."

Tuscher was giving Bacheta a taste of his own medicine, after the Brit had twice bided his time to pull off penultimate-lap moves for victory at Silverstone a fortnight earlier. On this occasion Tuscher couldn't pull it off. Perhaps due to his limited car-racing experience, he didn't quite have the commitment to make a move into the circuit's 100mph Turn 1. Nevertheless, the closeness

with which he tracked Bacheta was impressive.

Second qualifying cemented Tuscher's reputation within the F2 paddock. In a session that started on a damp track, he knew it was important to get in a fast lap with an already-burst cloud on the horizon. No sooner had he exited the final corner on his second timed lap than the heavens opened with rain and hail, causing chaos on the circuit. Many drivers – including Tuscher – got caught out and had harmless spins.

This was more than a question of timing: Tuscher's lap was impressive, and included sliding sideways all the way through the second corner.

At the start of race two



Race two qualifying turned wet for most

RACE RATING

★★★★☆

Tuscher v Bacheta was addictive, exciting scraps for lower positions

MILESTONE

Bacheta first man to break Andy Soucek's 2009 record of three F2 wins in a row



REPORT F2 ALGARVE

JACK NICHOLLS
reports



Bacheta won twice in Portugal

Bacheta managed to jump from third to first by the third corner, and the race panned out in exactly the same way as the previous day.

Tuscher stayed closer this time – within 0.6s for most of the race – but a lock-up from Bacheta on the penultimate lap was enough to distract Tuscher and send him wide at Turn 10, consigning him to second place. Again showing his self-awareness, he was circumspect at how the race had ended.

“Of course, there’s always disappointment when you come so close to winning, but this is only my second weekend in F2 and my second year in formula cars,” he said. “I hoped to be top 10, but never expected to be on the podium and challenging for the wins.”

His relaxed nature was a contrast to Bacheta, who admitted it had “been a physically draining weekend, having him [Tuscher] in my mirrors the whole

time. It’s a relief I managed to stay ahead.”

Of course, Bacheta’s weekend cannot be overlooked. He now has four wins out of four races, and a quarter of the way into the season holds a 46-point lead at the top of the championship. He appears to already have a tentative grasp on the prize Williams F1 test drive that befalls the champion, but he knows there’s a long way to go.

“The season has gone amazingly well, but I wouldn’t say it’s been easy at all,” he said. “That last race was definitely the most difficult.”

After celebrating his 22nd birthday the Thursday before the race, holding off a driver seven years his junior shows that despite his advantage Bacheta cannot afford to be complacent. He might not be old enough to drink the champagne on the podium, but Tuscher is certainly proving more than a match for his older rivals on the track. ☼

German challengers get on right track

Behind the Tuscher-and-Bacheta battle, the running order was a little less predictable in Algarve.

In the first race, ex-GP2 racer Kevin Mirocha got closest to running with the leaders. “I was right with them for the first few laps, but they’d only used one set of tyres in qualifying so had fresher rubber, and I couldn’t keep the pace,” he said. But after a difficult weekend at Silverstone, a third position put him on the right track.

Fellow German Markus Pommer also put a challenging opening round – where he lost confidence after crashing in first qualifying –

behind him. In race two in Portugal the German F3 graduate began to show the pace expected of a driver who comfortably topped the pre-season tests, passing Christopher Zanella for third place early on to move him into a position he never looked like relinquishing.

It was Silverstone’s frontrunners who were left struggling as Zanella, Mihai Marinescu and Alex Fontana all failed to make an impact in the major positions, the best being 2011 F2 runner-up Zanella’s fourth in race two.

Their inconsistency is playing right into Bacheta’s hands, and their hopes are now pinned on the dropped-

score system that F2 uses.

The new-for-2012 ‘boost zones’ continued to aid excellent racing. Mimicking DRS in F1, the 75bhp overboost can now only be used when within 1s of the car in front when in one of the two boost zones. At the Algarve circuit the chosen zones were the start/finish straight, and the run down to the Turn 5 hairpin.

A five-way battle over fifth position in race two was a highlight of the weekend, resulting in numerous changes of position. When the chequered flag fell there were just 3s between Brit Dino Zamparelli in fifth and Victor Guerin in ninth.



Big fight, as McKenzie leads Zamparelli

RESULTS

FIA Formula 2, Algarve (P), April 28-29, round 2 of 8

GRID	
1 BACHETA 1:34.135	2 POMMER 1:34.156
3 TUSCHER 1:34.317	4 MIROCHA 1:34.321
5 MCKENZIE 1:34.433	6 ZANELLA 1:34.456
7 FONTANA 1:34.533	8 ZHU 1:34.554
9 MARINESCU 1:34.572	10 ZAMPARELLI 1:34.771
11 HURST 1:34.854	12 SUR'WAREN 1:35.120
13 KRALEV 1:35.201	14 GUERIN 1:35.527
15 KHANI 1:35.649	16 SNEGIREV 1:35.746
17 CALANTA 1:36.084	

RACE 1 – 22 LAPS, 63.593 MILES			
POS	NAME	TIME	GRID
1	Luciano Bacheta (GB)	35m19.878s	1
2	Matheo Tuscher (CH)	+0.309s	3
3	Kevin Mirocha (DJ)	+16.307s	4
4	Markus Pommer (D)	+19.801s	2
5	David Zhu (PRC)	+24.106s	8
6	Christopher Zanella (CH)	+27.176s	6
7	Alex Fontana (CH)	+37.164s	7
8	Dino Zamparelli (GB)	+40.465s	10
9	Hector Hurst (GB)	+40.965s	11
10	Mihai Marinescu (RO)	+41.366s	9
11	Victor Guerin (BR)	+42.260s	14
12	Mauro Calamia (CH)	+42.797s	17
13	Daniel McKenzie (GB)	+43.311s	5
14	Kourosh Khani (IR)	+43.703s	15
15	Plamen Kralev (BG)	+49.179s	13
16	Parthiva Sureshwaren (IND)	+50.177s	12
17	Max Snegirev (RU)	+1m00.983s	16

GRID	
1 TUSCHER 1:52.543	2 ZANELLA 1:52.996
3 BACHETA 1:53.293	4 POMMER 1:53.788
5 ZAMPARELLI 1:53.789	6 GUERIN 1:54.013
7 MIROCHA 1:54.161	8 MARINESCU 1:54.297
9 HURST 1:54.381	10 MCKENZIE 1:54.393
11 SNEGIREV 1:54.535	12 FONTANA 1:54.998
13 ZHU 1:55.026	14 KHANI 1:56.361
15 CALANTA 1:57.039	16 SUR'WAREN 1:57.933
17 KRALEV 1:57.970	

RACE 2 – 22 LAPS, 63.593 MILES			
POS	DRIVER	TIME/REASON	GRID
1	Bacheta	35m42.111s	3
2	Tuscher	+1.514s	1
3	Pommer	+2.267s	4
4	Zanella	+6.425s	2
5	Zamparelli	+19.249s	5
6	McKenzie	+20.319s	10
7	Hurst	+20.722s	9
8	Mirocha	+21.733s	7
9	Guerin	+22.563s	6
10	Fontana	+29.288s	12
11	Calamia	+32.353s	15
12	Zhu	+44.624s	13
13	Kralev	+1m00.188s	17
14	Sureshwaren	21 laps-DNF	16
15	Snegirev	20 laps-DNF	11
R	Marinescu	2 laps-radiator	8
R	Khani	0 laps-collision	14

CHAMPIONSHIP TABLE		
POS	DRIVER	PTS
1	Bacheta	100
2	Tuscher	54
3	Zanella	42
4	Fontana	37
5	Pommer	37
6	Marinescu	31
7	McKenzie	30
8	Zamparelli	24
9	Mirocha	19
10	Hurst	15

Race 1 Winner's average speed: 108.00mph. Fastest lap: Tuscher, 1m35.531s, 108.93mph.
Race 2 Winner's average speed: 106.87mph. Fastest lap: Bacheta, 1m36.695s, 107.62mph.
All drivers in Williams-Audi JPH1B

INTERNATIONAL RACES & RESULTS
NASCAR SPRINT CUP
Richmond (USA), Rd 9/36

QUICK RESULTS
→ Winner **Kyle Busch**
→ Pole **Mark Martin**
→ Most laps led **Carl Edwards**
→ Points leader **Greg Biffle**

RACE RATING Great racing and controversial calls on unusual D-shaped oval
★★★★☆

NASCAR SPRINT CUP RICHMOND (USA), APRIL 28, RD 9/36

Busch gets the rub of the green



Slick pitwork got Busch ahead of Stewart

KYLE BUSCH WON HIS fourth straight spring Richmond to open his 2012 Sprint Cup account.

The Joe Gibbs Racing driver took full advantage of some great pitwork during the fifth and final caution of the race to move ahead of Tony Stewart and into the lead. He nailed the final restart in his Toyota Camry and, with Stewart slipping behind Dale Earnhardt Jr's Hendrick Chevrolet, Busch had a clear run to the flag.

Stewart had the race in the bag until the final yellows came out for debris on the track. "When the caution is for a plastic bottle on the backstretch, it's hard to feel good about losing," said the champion.

But Stewart owed his

place at the front to a black flag shown to Carl Edwards, who'd dominated the race in his Roush Fenway Ford. Edwards was penalised for jumping the restart after the penultimate caution but, with the scoring tower indicating that he had the lead (not Stewart as the officials reckoned), and Stewart alongside him spinning his wheels, it was a marginal call.

Busch's team-mate Denny Hamlin was fourth ahead of Kasey Kahne (Hendrick). Following a poor qualifying session Jimmie Johnson drove a great race to run at the front but, when one of his crew rolled a wheel to the pitwall rather than carrying it, he received a drivethrough that

ended his chances.

Clint Bowyer also raced his way through the field from a lowly 23rd on the grid in his Michael Waltrip Racing Toyota to take seventh, one place ahead of team-mate Mark Martin, who started from pole. The veteran's top starting spot came 31 years after his first Richmond pole. While he led the opening 31 laps, he gradually slipped down the order to eighth.

Brad Keselowski took ninth in his Penske Dodge ahead of the frustrated Edwards. Roush's points leader Greg Biffle had a quiet run to 18th, and his championship lead has been reduced to just five points over Earnhardt.

● Connell Sanders Jr

RESULTS

1 Kyle Busch (Toyota Camry), 400 laps in 2h51m06s; 2 Dale Earnhardt Jr (Chevrolet Impala) +1.095s; 3 Tony Stewart (Chevy); 4 Denny Hamlin (Toyota); 5 Kasey Kahne (Chevy); 6 Jimmie Johnson (Chevy); 7 Clint Bowyer (Toyota); 8 Mark Martin

(Toyota); 9 Brad Keselowski (Dodge Charger); 10 Carl Edwards (Ford Fusion). **Points** 1 Greg Biffle, 338; 2 Earnhardt, 333; 3 Hamlin, 329; 4 Matt Kenseth, 328; 5 Martin Truex Jr, 316; 6 Johnson, 314; 7 Kevin Harvick, 313; 8 Stewart, 307; 9 Edwards, 287; 10 Ryan Newman, 278.

KYLE BUSCH MOTORSPORTS TAKES FIRST NATIONWIDE WIN... with the owner's brother Kurt (54) at the wheel of the Toyota. He beat Denny Hamlin's Joe Gibbs Toyota by 0.062s. Ricky Stenhouse Jr cut Elliott Sadler's championship lead to just two points by finishing fourth.



Castrol EDGE

CURRENT STANDINGS

- 1 **Sebastian Vettel** ◇ 29,045
- 2 **Mark Webber** ◇ 21,225
- 3 **Jenson Button** ◇ 19,708
- 4 **Lewis Hamilton** ◇ 19,456
- 5 **Fernando Alonso** ◇ 18,660

Ranking the world's best drivers.....

WHAT HAPPENED THIS WEEK

Gary Paffett's first DTM win for over a year moves him up 15 places to 99th, while Mercedes team-mate Jamie Green (69) makes up 17 spots. Reigning champion Martin Tomczyk's DNF at Hockenheim for BMW drops him two places to 58th.

To see the full list, visit castroldriverrankings.com

FORMULA 3 EURO SERIES/FIA EUROPEAN F3 CHAMPIONSHIP HOCKENHEIM (D), APRIL 28-29, RD 1/8 AND 1/10

Juncadella on top with perfect Prema

DANIEL JUNCADILLA AND Raffaele Marciello gave Prema Powerteam a perfect start to its bid to repeat Roberto Merhi's F3 Euro Series title of 2011, locking out the wins at Hockenheim.

Juncadella was not the out-and-out fastest man at Hockenheim. That honour went to British F3 points leader Carlos Sainz Jr, who stuck his Carlin Dallara-Volkswagen on pole twice (helped by Juncadella snapping a suspension rod against a kerb late on). But Sainz's downfall came as he fluffed his starts in races one and three.

In the opener he slipped behind front-row starter Felix Rosenqvist at the first corner and was then overhauled by Juncadella on the second lap. Both Spaniards made it by the Mucke-run Swede – who struggled for straightline speed all weekend – but there was no battle as Juncadella built a 3s lead.

Race three was going the

same way until Juncadella, who retired from the reversed-grid race when contact with Sainz's team-mate Will Buller broke his front wing, began to suffer with his rear tyres.

"I missed a couple of shifts from first to second out of the hairpin," he said. "And that gave me wheelspin which took the life out of the rear tyres. Then he was able to close."

Close Sainz did, to just 0.7s behind by the finish.

Rosenqvist took a hat-trick of third places in what the Swede described as "not a great start" after his car languished near the bottom of the speed traps all weekend. In the reversed-grid race he was only beaten by rookie winner Marciello and Hannes van Asseldonk, on a one-off Euro Series appearance with Fortec.

Buller finished all three races in the top six in the second Carlin machine, while Alex Lynn took a fine fourth in race three, 24



Juncadella beat Sainz for two German wins

hours after contact with the impressive Sven Muller (Prema) at Turn 2 dropped both to the tail of the field in race one. Muller pulled off some brave passing moves during the weekend and scored his best result in race three with fifth.

● Jamie O'Leary

RESULTS

Race 1 1 Daniel Juncadella (Dallara-Mercedes F312), 25 laps in 39m50.239s; 2 Carlos Sainz Jr (Dallara-Volkswagen F312) +3.683s;

3 Felix Rosenqvist (DM); 4 Will Buller (DV); 5 Hannes van Asseldonk (DM); 6 Raffaele Marciello (DM). **Race 2 1 Marciello**, 13 laps in 20m50.142s; 2 van Asseldonk +5.976s; 3 Rosenqvist; 4 Buller; 5 Sainz; 6 Sven Muller (DM). **Race 3 1 Juncadella**, 25 laps in 39m38.962s; 2 Sainz +0.763s; 3 Rosenqvist; 4 Alex Lynn (DM); 5 Muller; 6 Buller. **Points Euro Series** 1 Juncadella, 50; 2 Sainz, 41; 3 Rosenqvist, 38; 4 Buller, 28; 5 Marciello, 21; 6 Muller, 16. **FIA** 1 Juncadella, 50; 2 Sainz, 36; 3 Rosenqvist, 30; 4 Buller, 20; 5 Muller, 10; 6 Marciello, 8.

INTERNATIONAL GT OPEN ALGARVE (P), APRIL 28-29, RD 1/8

Holzer and Tandy are very handy for double

NICK TANDY AND MARCO Holzer guided their Manthey Racing Porsche 911 GT3-RSR to a double victory at the Algarve, aided by some cracking tyre choices on a weekend of unpredictable weather.

In race one, AF Corse Ferrari driver Toni Vilander began to pull away on a

drying track, but when the time came to change to slicks it was Holzer who chose the perfect moment, handing over to Tandy at the same time. But with tyre changes not allowed during driver swaps, Briton Tandy then had to take a drivethrough penalty.

By that stage, some

blistering laps had given Holzer enough of a gap to take the penalty without losing the lead. He pitted, changed to slicks and handed over to Tandy, who emerged in the lead. Kessel Ferrari duo Philipp Peter/Michal Broniszewski were second, with Patrick Pilet/Raymond Narac third in their Insa Porsche.

Tandy preserved his slicks on a damp track early on in race two and was third when he pitted, behind Peter Kox and Marco Mapelli. But once in the car Holzer was able to pass their respective co-drivers Nico Pronk (Lamborghini) and Archie Hamilton (Porsche) within a few laps to win again.

Pilet/Narac were second

ahead of Mapelli/Hamilton, who took a class win in GTS. ● Jack Nicholls

RESULTS

Race 1 1 Nick Tandy/Marco Holzer (Porsche 911 GT3-RSR), 35 laps in 1h10m59.359s; 2 Philipp Peter/Michael Broniszewski (Ferrari 458 Italia) +7.651s; 3 Stefano Bizzarri/Niki Cadei (Ferrari GT3); 4 Patrick Pilet/Raymond Narac (Porsche); 5 Raffaele Giammaria/Miguel Ramos (Ferrari); 6 Jose Ramos/Patrick Pereira da Cunha (Lamborghini Gallardo LP600+). **Race 2 1 Tandy/Holzer**, 27 laps in 51m57.143s; 2 Pilet/Narac, +13.179s; 3 Archie Hamilton/Marco Mapelli (Porsche GT3); 4 Bizzarri/Cadei; 5 Alvaro Barba/Matteo Malucelli (Aston Martin Vantage); 6 Ramos/da Cunha. **Points** 1 Tandy/Holzer, 40; 2 Bizzarri/Cadei, 32; 3 Pilet/Narac, 30; 4 Hamilton/Mapelli, 29.



Manthey Porsche duo did double

IN BRIEF

Edwards was denied double



CARRERA CUP GERMANY

When Sean Edwards hit a kerb hard and sustained a front-left puncture, his Tolimit team-mate Rene Rast inherited victory at the Hockenheim season opener. Briton Edwards won race two.

VLN

Marc Lieb and Jochen Krumbach made it back-to-back wins on the Nordschleife in their Manthey Porsche 911 GT3, a lap ahead of the Christopher Mies/Markus Winkelhock Phoenix Audi R8 LMS.

VW SCIROCCO CUP

Ola Nilsson kicked off 2012 with a win at Hockenheim, beating Mika Salo by 0.5s after the ex-F1 man used up all his 'push-to-passes' in the first half of the race. Jann-Hendrik Ubben was third.

EUROPEAN F3 OPEN

A win and a second for Mans Grenhagen at the Algarve circuit gave the Swede the points lead. Mexican Juan Carlos Sistos, who like Grenhagen drives for Emilio de Villota's team, won race one.

V8 SUPERTOURERS

Former A1GP frontrunner Jonny Reid took a double win at Manfeild in his International Motorsport Ford Falcon. Andy Knight and John McIntyre each had a second in their M3 Fords.

EUROPEAN TOURING CARS

When Fernando Monje suffered a last-lap puncture, his SUNRED SEAT team-mate Michal Matejovsky pounced to win race one at the Slovakia Ring. Petr Fulin won race two in his BMW.



Matejovsky (r) won



PETTER SOLBERG SUPPORTERS CLUB! JOIN NOW!

www.pettersolberg.com





28 JUNE – 1 JULY 2012



EXHIBIT AT THE GOODWOOD FESTIVAL OF SPEED

- Over 180,000 visitors over four days
- The world's most important motor manufacturers and over 200 top international brands exhibiting
- Gain exposure to an affluent target consumer audience from around the world
- A range of exhibitor packages available

For more information about exhibiting email: exhibitions@goodwood.com or call +44 (0)1243 755081
To book tickets call +44 (0)1243 755055 or visit

www.goodwood.com





Scottish Championship Car Racing SAT 5th & SUN 6th MAY



A superb range of racing classes, a super-slick racing format with and around 18 races to entertain you during an action-packed weekend. **Book tickets now!**

KNOCKHILL.COM





British Rallycross Championship SATURDAY 12th MAY



Rallycross is an exciting form of racing which will have you on the edge of your seat with its short, sharp races and superb mix of rally-racing. **Book tickets now!**

Action starts at 1pm
and finishes around 8pm





INTERNATIONAL RACES & RESULTS

GRAND-AM

Homestead (USA), Rd 3/12

QUICK RESULTS

- Winners **Taylor/Angelelli**
- Pole **Potolicchio**
- Fastest lap **Westbrook**
- Points leaders **Pruett/Rojas**

RACE RATING

★★★★☆

Torrential rain is the big winner in Florida

REPORTS

WORLD OF SPORT

GRAND-AM HOMESTEAD (USA), APRIL 28, RD 3/12

SunTrust in the rain for Angelelli and Taylor



Angelelli/Taylor took a wet win

AS HARD AS THE GRAND-AM drivers tried to put on a show for the fans who turned up on a miserable wet weekend at Homestead, it was the weather that won as officials red-flagged the race for good with almost an hour still to run.

Max Angelelli and Ricky Taylor took victory in their

SunTrust/Wayne Taylor Racing Riley Corvette DP as reigning champions Scott Pruett and Memo Rojas vaulted from fifth to first in the points by virtue of finishing second in their Ganassi Riley-BMW.

Starworks Riley driver Enzo Potolicchio, who started from pole once rain

forced the grid to be set in championship order, was unfazed by the terrible conditions that also prevailed on Sunday. He did well to fend off an initial challenge from Richard Westbrook's Spirit of Daytona Coyote Corvette.

But a mistake by the Venezuelan gave Westbrook

the lead, and he held it until his rival clipped him 15 laps later, sending him into a spin for which Potolicchio was given a stop/go penalty.

That incident allowed Taylor – who had taken over from Angelelli by that point – to assume the lead, while Potolicchio's co-driver Ryan Dalziel was

forced to drive through the field in recovery. He finished sixth in class.

Westbrook fought back to third before handing over to Antonio Garcia, but their strategy did not pan out as the rain worsened again and the race was abandoned.

GT honours – and sixth overall – was taken by 2010 champions Emil Assentato and Jeff Segal in their AIM Autosport Ferrari 458.

● Jeremy Shaw

RESULTS

1 Max Angelelli/Ricky Taylor (Dallara Corvette DP), 54 laps in 1h53m09.242s; 2 Memo Rojas/Scott Pruett (Riley-BMW MkXXVI), +0.603s; 3 David Donohue/Darren Law (Riley Corvette DP); 4 Alex Popow/Lucas Luhr (Riley-Ford MkXI); 5 Richard Westbrook/Antonio Garcia (Coyote Corvette DP); 6 Emil Assentato/Jeff Segal (Ferrari 458 GT).
Points 1 Rojas/Pruett, 87; 2= Enzo Potolicchio/Ryan Dalziel & Popow/Luhr, 85; 4 Garcia/Westbrook, 84; 5 John Pew/Oswaldo Negri Jr, 82; 6= Angelelli/Taylor & Donohue/Law, 78.

BRITISH RALLY CHAMPIONSHIP PIRELLI RALLY (GB), APRIL 27-28, RD 3/6

Cronin wins Pirelli battle of wits with Nikara

TWO-TIME BRITISH RALLY champion Keith Cronin returned to form last weekend as the Irishman stormed to victory on the Pirelli International Rally.

Hot on Cronin's heels for much of the Cumbrian event was Finn Jarkko Nikara, who led after Friday's first two stages.

A storming time from Cronin on Saturday's opening eight-mile test kicked off a head-to-head battle between the Citroen team-mates, with the pair swapping positions on three occasions. Only 0.3 seconds separated them at the end of SS6, but four straight stage wins from Cronin ensured that he reached

the finish 17.2s ahead.

"It's been a fantastic battle and a win always feels so much better when you have to fight for it," said Cronin. "Once we'd settled into the new car and tweaked a few things we had no problems at all, so it's been very enjoyable."

After gathering confidence throughout the rally, round one winner Mark Donnelly took the third podium spot in his Renault. Following them home in fourth was WRC Academy star Elfyn Evans at the wheel of a Ford Fiesta R2. Evans's fourth place also launched the Welshman to the top of the drivers' standings, three points



Cronin took Pirelli victory in Citroen

ahead of Tom Cave.

Fifth was Peter Taylor in another Renault, 1.8s ahead of Finn Jukka Korhonen, who secured his best result of the season so far in a Skoda Fabia R2.

At the season's mid-point, with only nine

points separating the top five drivers, the coveted British title remains very much up for grabs.

● Graham Lister

RESULTS

1 Keith Cronin/Marshall Clarke (Citroen DS3 R3), 1h29m51.3s;

2 Jarkko Nikara/Petri Nikara (Citroen), +17.2s; 3 Mark Donnelly/Dai Roberts (Renault Clio R3); 4 Elfyn Evans/Phil Pugh (Ford Fiesta R2); 5 Peter Taylor/Andrew Roughead (Renault); 6 Jukka Korhonen/Mikael Korhonen (Skoda Fabia R2). **Points** 1 Evans 45; 2 Tom Cave 42; 3 Cronin 38; 4 Taylor, 38; 5 Donnelly 36; 6 Nikara, 34.

THE SCIENCE OF (EXTRA) SPEED

Dallara's new FR 3.5 racer is way quicker than the 2011 car. **GLENN FREEMAN** explains why, with some inside info

Lap records have been smashed in pre-season testing. At each circuit the Formula Renault 3.5 field has visited in recent weeks, it's taken the frontrunners hours rather than days to surpass the quickest times ever set by the Dallara T12's predecessor during its four years of service. And we're talking by seconds, not just tenths of seconds.

Those lap times have added to a buzz that has been growing around this championship for nearly a year. Renault released the first major details of its

plans for its 2012 racer at the Monaco Grand Prix last year, and as the season went on word started to get out that it was going to cost around half of a GP2 budget to race for the year. Drivers from all sorts of single-seater series have flocked to the grid for 2012, leaving the headline act on the World Series by Renault bill with potentially its strongest ever grid.

So what's all the fuss about? Carlin's Paul Wallace, who engineered Robert Wickens to the 2011 title, talks AUTOSPORT through the key changes to the latest FR 3.5 racer.

TYRES/SUSPENSION

The dampers are new for this year, but probably the biggest influence on set-up in this area is that they've had to stiffen the sidewall of the tyre to cope with the downforce. Even though the compound is the same, the sidewall stiffness is a lot higher, so the tyre has quite a different characteristic. And that has affected the ratio between how the tyre flexes compared with the suspension, so we've had a rethink on that as well.

BRAKES

The brakes are all-new. With six-piston calipers compared with fours we had last year, they seem to be an improvement. We haven't noticed any major difference in the temperatures or how we have to use them, because the material is quite similar to last year. But they've stiffened up a bit so the feel has improved, and because of the downforce we're pulling over 4g under braking now, compared with high 3s before.

AERODYNAMICS

The downforce is massive – about 30 per cent more than last year, and I think it's got more downforce than a GP2 car. We certainly seem to be quicker than them in the corners. This is the biggest difference between the old and new cars, and getting the drivers to believe in the amount of grip the car now possesses has been one of the main things to work on.

DRAG-REDUCTION SYSTEM

The DRS seems pretty effective, and because the drivers can knock the drag off on the straights we are tending to run higher wing levels this year, which makes for a major speed gain when they press the button. The only real issue with it is the position of the button on the steering wheel. The drivers are getting a sore thumb from holding it down for so much of the lap.

PHYSICAL CHALLENGE

I think it took both of our drivers by surprise just how much downforce there was going to be. The forces under braking and the effort required on the steering wheel mean they've had to up their training a bit to get used to it.

ENGINE

The engine has 50 more horsepower but I think because of the downforce it's not that noticeable. The biggest difference is that this new V8 [up from a V6] produces a whole lot more vibration than last year, so we're finding that things that didn't used to fall off *are* falling off. So we have to keep a very close eye on things and treat it like a 100 per cent new car even though it's not.

ELECTRONICS/PNEUMATICS

The basic mechanicals are the same as the old car, and it's bolted together the same, but pretty much all of the running gear is different. So we've had to focus on getting everything right so that there's enough air pressure, and that the voltage is right in the capacitor. If the car goes out without enough of one or the other, that can cause it to stop on track.

AUTOSPORT

SAVE 18% ON THE COVER PRICE

WORTH £35 RRP



FREE PUMA TEAM BAG

WHEN YOU SUBSCRIBE TO AUTOSPORT

JUST ~~£3.40~~ £2.79 PER ISSUE



GREAT REASONS TO SUBSCRIBE

- **FREE** Puma team bag worth £35
- **SAVE 18%** on the cover price
- **SPREAD THE COST** - just £36.25 every 13 issues with easy direct debit instalments
- **FREE P&P** - every issue delivered to your door

Subscribe online at:

www.themagazineshop.com

www.themagazineshop.com/ASPO/M0512P

Or call our hotline and quote offer code M0512P:

08448 488 817



+



+

FREE DELIVERY

Offer closes June 7, 2012. Please have your bank details ready

Terms and conditions: This is a direct debit offer open to readers in the UK only. Overseas rates are available by calling +44 (0)1795 592 974 or for US rates call +1 866 978 1446. Offer closes June 7, 2012. Direct debit prices are valid for one year, after which they are subject to change. Should prices change you will be informed in writing. Please allow 35 days for delivery of your first issue and gift. Gift will be sent under separate cover. Should we run out of gifts you will be offered an alternative - there is no cash alternative.

PAST FIVE CHAMPIONS

2011	Robert Wickens (Carlin)
2010	Mikhail Aleshin (Carlin)
2009	Bertrand Baguette (Draco)
2008	Giedo van der Garde (P1)
2007	Alvaro Parente (Tech 1)



Williamson races for Arden



DAMS has added FR 3.5 to GP2 effort

WHERE TO WATCH ON TV

Eurosport will show live or delayed coverage of all the races in 2012. Motors TV will also show highlights.

FORMULA RENAULT 3.5 2012 CALENDAR

May 5-6	Aragon, Spain
May 26-27	Monaco
June 2-3	Spa, Belgium
June 30-July 1	Nurburgring, Germany
July 14-15	Moscow, Russia
August 25-26	Silverstone, Great Britain
September 15-16	Hungaroring, Hungary
September 29-30	Paul Ricard, France
October 20-21	Barcelona, Spain

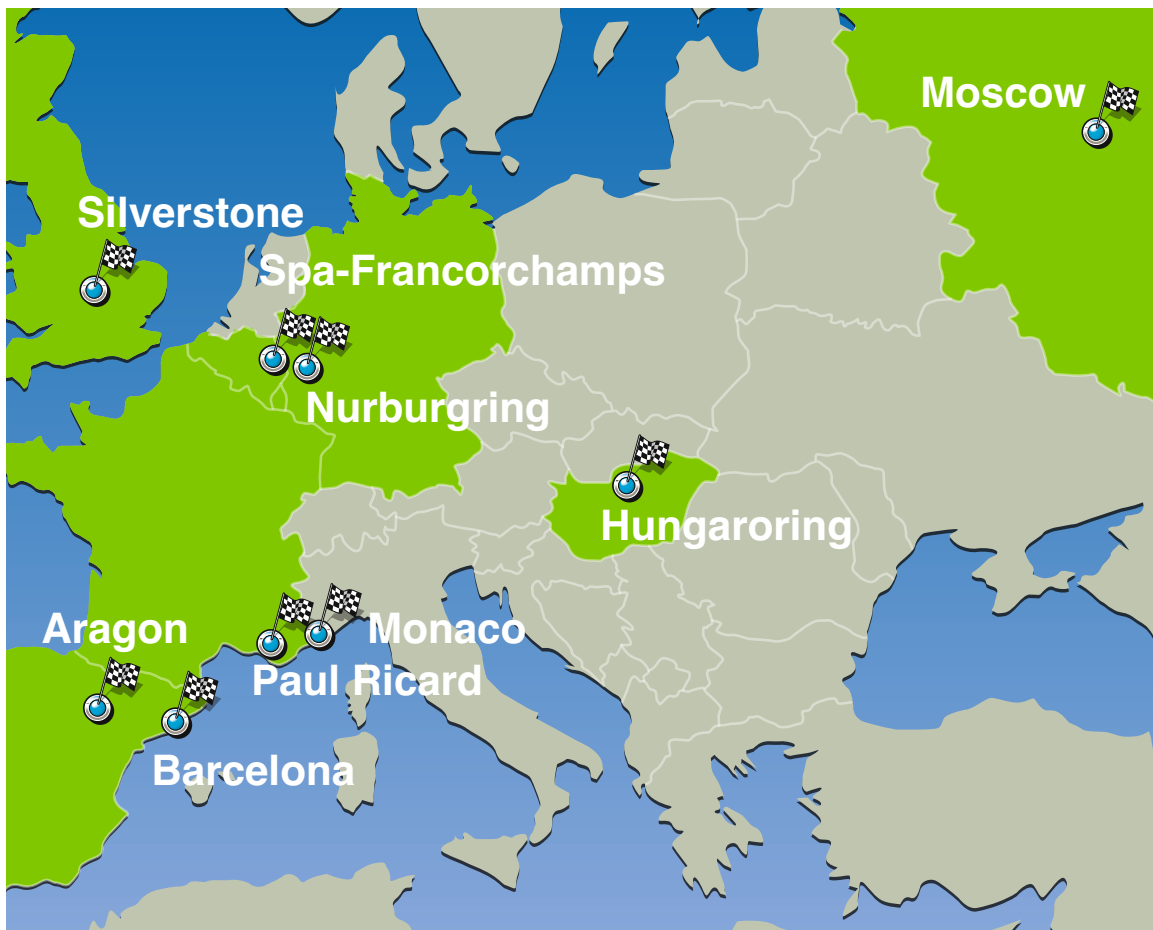

Frijns has shown well in testing



ONES TO WATCH

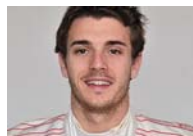

Jules Bianchi (Tech 1 Racing)

With Ferrari watching his every move through its junior-driver programme, and F1 seat time on GP weekends courtesy of Force India, Bianchi has a lot on his plate this year. But he was keen to race as well.



Sam Bird (ISR)

Like Bianchi, Bird is GP2 big hitter who's moved across as FR 3.5 gathers momentum. Bad luck might have taken the wind out of his GP2 sails last year, but his performance there in '10 suggests he's a quick learner.

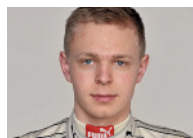

Kevin Magnussen (Carlin)

Felipe Nasr, who beat Magnussen to last year's British F3 title, has made an impressive start to life in GP2. So it would be reasonable to expect his former rival to do the same here as Carlin bids for three titles in a row.

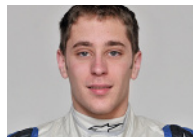

Robin Frijns (Fortec Motorsports)

There was plenty of buzz around the reigning FRenault Eurocup champion, then he went fastest on four of the six pre-season test days. His fate could depend on how hard the more experienced drivers pushed in testing.



Richie Stanaway (Lotus)

The German F3 champion steps up having boosted his reputation with a 2011 late-season cameo in GP3 that yielded a win in his second start. Being with Gravity can be a good for you, too – just ask Romain Grosjean.

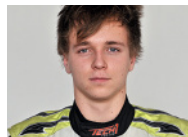

Kevin Korjus (Tech 1 Racing)

The Estonian was a standout performer in last year's field, taking three wins and P6 in the points to build on his FRenault Eurocup title the year before. Team continuity with Tech 1 could be a trump card.

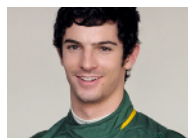

Alexander Rossi (Arden Caterham)

There will be plenty of eyes on Rossi, the highest-placed returning driver from '11. Third behind Wickens and F1-bound Vergne was a fine effort as a rookie, but this year could be tougher with a new-to-FR 3.5 team.



Lewis Williamson (Arden Caterham)

Red Bull saw the performances behind P8 in GP3 last year, but that doesn't mean the pressure will ease on the Scot as he steps up a level. Like Rossi, his fate could depend on how Arden gets to grips with FR 3.5.

PRODUCT SHOWCASE

AVLL AERO TEC LABORATORIES LTD.



Your one stop Racing Fuel System Shop... please contact our UK stockists:

0844 815 8610 • sales@demon-tweaks.co.uk
www.demon-tweaks.co.uk

0208 655 7877 • info@msar-safety.com
www.msar-safety.com



www.atltd.com



Racing Car Air Lift



- Lifts Vehicles Safely and Quickly
- Supplied Tested and Ready to Use
- 600 Kg S.W.L. Per Pair

Call for a Quote Today!

Tel: 024 7637 4114
Fax: 024 7634 7520
Email: sales@camozzi.co.uk
Web: www.camozzi.co.uk



CARTEK



Coolant Level Alarm

The Coolant Level Sensor from **CARTEK** offers drivers an early warning function should their engine cooling system develop a leak, such as a punctured radiator, loose hose or gasket failure before overheating and engine damage occurs.

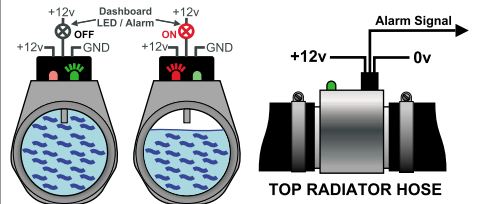

CARTEK AUTOMOTIVE ELECTRONICS Ltd
www.CARTEKMOTORSPORT.com

ECU/Exchange Loom/Throttle Body Packages available

Complex modern engine? No problem

Our ECU's are capable of dealing with the most complex of modern engines without the need to change sensors or sacrifice key features such as variable camshafts.



ECU solutions for:
Honda S2000 and K20A
Ford ST170 and Duratec
Toyota 2ZZ
BMW Single
BMW Twin VANOS
Audi 1.8T and 5 cylinder
Chevrolet LS7.



Get the very best from any engine and from only **£495.00 + VAT.**

DTAfast, 10 Boston Court, Kansas Ave, Salford M50 2GN
Tel: +44 (0)161 877 1419 Fax: +44 (0)161 877 7086
Email: office@dtafast.co.uk Website: www.dtafast.co.uk

OLDHALL PERFORMANCE

Bringing high quality automotive performance products from around the World



Tel: +44 (0)24 76 717100 Fax: +44 (0)24 76 717400
www.oldhallperformance.com sales@oldhallperformance.com
Old Hall Performance Ltd Burnshall Road Coventry CV5 6BU

Anglian Fasteners

- Major stockist and distributor of high grade Unbrako and Holokrome socket products.
- Standard and special fasteners available to order.
- Full range of zinc, stainless steel & Brass fasteners in stock.
- Aluminium, titanium, nylon & other materials.
- Loctite, Dormer (drills, taps and dies), maintenance sprays & lubricants and handy boxes of assorted components from stock or filled to your requirements.
- Extensive range of dowel pins, rivets, hexagon head screws, bolts, nuts, washers, self-tapping screws, machine screws. In fact, whatever you need...



If it's threaded – call us!

We offer next day delivery on all stocked items within the UK and can ship worldwide to meet your requirements.

Contact us or visit one of our trade counters in Bedford or Northampton:

www.anglianfasteners.co.uk

Bedford 01234 345641 Northampton 01604 645341
email info@anglianfasteners.co.uk

CARTEK BATTERY ISOLATORS

Developed specifically for motorsport applications the Solid State Battery Isolator from **CARTEK** is a major advance in the safety and reliability of race vehicles.



Fully electronic with no moving parts makes this system highly resistant to shock, vibration, water and dirt.

Superior to traditional mechanical master switches, this push-button system provides safe and instant spark-free isolation of the vehicle's battery and engine kill meeting FIA regulations.

Used by:



AMG SLS GT3s
1st, 2nd, 3rd
Dubai 24hr



FIA European
Rallycross
champion 2011



Formula Ford
EcoBoost cars
2012

CARTEK AUTOMOTIVE ELECTRONICS Ltd
www.CARTEKMOTORSPORT.com

AUTOSPORT

PRODUCT SHOWCASE

ADVERTISE YOUR NEW
2012 PRODUCTS AND
SERVICES HERE ON

0208 267 5367

BRISE www.brise.co.uk 01322 277622

High Performance Alternator and Starter Motors



WEB DIRECTORY

BOOKS

www.chaters.co.uk

Probably the World's LARGEST selection of Motoring Books & DVD's
Tel: 01276 686639 - Fax: 01276 686538



CAR BROKERAGE

RACING CARS FOR SALE

ALAN CORNOCK FCS
BUYING - SELLING - BROKERAGE
www.racingcarsforsale.co.uk
TEL: 01480 891212

ENGINE TUNING

CNC Heads

CNC PORTING FOR MOST
MAKES. HEADS SCANNED
& MACHINED FOR ENGINE
BUILDERS

+44 (0)161 483 4810

EXHAUSTS

Inconel & Stainless Steel Specialists

SIMPSON
Race Exhausts

Tel: 01753 532222
www.simpsonraceexhausts.com

GEARBOXES



Rally & Race Gearboxes,
GearKits, LSD's and Driveshafts

Tel: 01782 280136 Fax: 01782 269913
Email: sales@eliteracingtransmissions.com

www.eliteracingtransmissions.com

Gearboxman.com

COMPETITION TRANSMISSION SERVICES

Gearboxes and Axles for Road, Race, Rally, and more

Telephone: 01582 840008, Fax: 01582 840007

HELMET GRAPHICS

Mike Fairholme Designs

Sole approved painter of Asai helmets.
Silver Birches, Corby Birkholme, Nr Grantham, Lincs NG33 4LE.

Tel: 01476 550630, Fax: 01476 550029.

email: fairholmedesigns@btconnect.com

www.fairholmedesigns.co.uk

MEMORABILIA



For Everything Formula One

www.finallap.net WE BUY AND SELL
+44 (0)1245 287588 / 07771 920345

MEMORABILIA

JM AUTO America's #1 supplier
of CART and Formula
One Racing memorabilia. Large selection of signed
original collectables. See our ad under marketplace
Memorabilia. Call or fax or a mail listing at (609) 575 1143
or visit our website @ www.JMAuto.com

MERCHANDISE



F1 Merchandise bought and sold.

Meadowhall, Sheffield

Tel: 0114 256 9835

www.theformula1shopandmore.co.uk

MOTORHOMES

BRIAN JAMES TRAILERS

CLUBMAN

Tel. 01327 308833

Web. **www.brianjames.co.uk**

JW Green Trailers

for BRIAN JAMES TRAILERS

Stock Ready For Delivery

Tel: 0333 456 0222 Mob: 07785 230560

www.jwgreen.co.uk

RACE PARTS

ARE DRY SUMP SYSTEMS
ARMSTRONG RACE ENGINEERING INC.
WWW.DRYSUMP.COM (916) 652-5282

CARTEK
Electronic Battery Isolators
Don't compromise
on Safety or Reliability
www.CartekMotorsport.com

PIPER
www.pipercams.co.uk

RACE PRODUCTS

Pit to Car Radio
0044(0)1508
528837
AUTOTEK
RACE RADIO
www.raceradio.co.uk

RACE PRODUCTS

demon-tweeks
MOTORSPORT Direct
www.demon-tweeks.co.uk

msar LONDON
MOTORSPORT
SHOWROOM
www.msar.co.uk

Position Sensors Ltd
Motorsport Specialist
www.position-sensors.co.uk

SCHROTH
RACING
www.schroth.com

RACE PRODUCTS

www.porscheshop.co.uk
PORSCHESHOP
+44 (0) 121 585 6088

JJC race and rally
PASSIONATE ABOUT MOTORSPORT
www.jjcraceandrally.com

GPR Grand Prix Racewear
THE RACEWEAR EMPORIUM
www.gprdirect.com

ALL OMP RACEWEAR
AVAILABLE NOW
OMP
www.ybracing.co.uk

RACING OILS

WWW.ROYALPURPLE.CO.UK
ROYAL PURPLE
SYNTHETIC RACE OILS
01209 216 666

OLD HALL PERFORMANCE LTD
RED LINE Tel: +44 24 7671 7100
SYNTHETIC OIL Fax: +44 24 7671 7400
sales@redlineoil-europe.com **www.redlineoil-europe.com**

LISTA
www.listacabinets.co.uk
Tel: 01228560911 07733157911

Image Manufacturers of bespoke
split rim alloy wheels
www.imagewheels.co.uk
IMAGE WHEELS INTERNATIONAL LTD

STORAGE

WHEELS

AUTOSPORT.COM

TO ADVERTISE IN THE WEB DIRECTORY PLEASE CALL
020 8267 5865 OR EMAIL: autosport.ads@haymarket.com

TRAILERS & TRANSPORTERS



Call Us Now! tel. 01327 263 384

www.woodfordtrailers.com sales@woodfordtrailers.com

RL 5000
£7,300 + vat



RL 6000
£9,500 + vat



Look Beyond



optional colour finishes shown

PRG Trailers | Cheshire | UK | Tel: +44 (0) 1270 812402
Web: www.prgtrailers.co.uk | Email: info@prgtrailers.co.uk



4.0mtr High Fixed Double Deck Race Car Transporter Trailer.
Ideal for European Use. Ready for internal conversion for workshop and living quarters.

2007 Gray & Adams Triaxle trailer, Painted White, Fixed Top Deck 1600mm high.

Full MOT, 2 tonne car tail lift.
£20,000 ONO.

Full internal conversions and livery can be completed to your specifications.



Dave Mob 07795 647824. Landline 0161 494 9241.

SPIRES HOSPITALITY

••• For Hire or possibly for sale! •••

The above company has available to hire on some dates during 2012 a 16 mtr Articulated Hospitality Unit. This vehicle is fully self contained with a full commercial kitchen, central office and lounge area.

Exterior flooring, chairs etc also included with primary 5 mtr awning and secondary 4 mtr to second side if required. Suitable for Teams/Event Sponsors/or as a Race Centre etc etc.

Hospitality service can be provided by this company with over 30 years experience at all levels of motorsport including F1, WRC, Le Mans etc and references can be provided if required.

For further details contact Stuart or Diana Spires

Mobile: **44 7768 256524**

Email: studispires@hotmail.com



For sale MAN new October 06 custom built Motor Home luxury living with large storage AT rear many uses i.e. motor cross go carts etc cost over 80,000 pounds new only 36,000 miles full service records fully automatic tip tronic drives like a car taxed and mot under 7.5 so drives car license extremely good condition.

Asking **£39,000 plus VAT**

tel: **01425402229 / 07785537935**



Currently in production. Tri-axle, step frame race transporter



Bespoke race transporters designed, built and refurbished to your requirements

- Will carry 4 cars
- Front living area with 2 pod
- Hydrovane compressor
- Honda generator



For further information, please contact Ian Green
Tel/Fax: 044 (0) 1454 227 191 Mob: 07766108873



Unit D16, Backfield Farm
Business Park, Wotton Road,
Iron Acton, Bristol, BS37 9XD

www.gbmotorsports.co.uk

Highest approval rating

During 2012 all new trailers sold across Europe must be manufactured to an approved European standard of construction and design.

Brian James Trailers have attained the highest level of European Whole Vehicle Type Approval for each of our trailer types.

Owning a new Brian James Trailer has always guaranteed qualification, now it puts you in pole position.

Race Transporter

For the first time possibilities exists for racers to specify a high quality, robust transportation trailer incorporating full race meeting workshop facilities. Choose from an extensive range of trailer sizes and capacities, then select the support equipment you need to suit requirements. Race Transporter trailers all feature new light panel constructions and advanced new, lightweight chassis.



Clubman & Clubman Tilt-bed

For a generation the Clubman range has defined value for money and choice. The latest designs feature many enhancements that all users will benefit from.



Clubman - Tiltbed model 100-0510
 4.3 m (14ft) Long, 1.90m (6ft 3) wide
 2000 Kg gross capacity
 Range from £ 1,809 plus vat

TT Tilt-bed range



A-max range



Visit the Brian James Trailers web site at www.brianjames.co.uk for full pricing details of the product range and our extensive national dealer network.

Models shown may feature optional equipment

BRIAN JAMES TRAILERS
www.brianjames.co.uk Tel. 01327 308833

RACE & RALLY CARS

DRIVES AVAILABLE



WANT TO RACE YOUR FERRARI, GINETTA G50, GR8, PROSPORT, BMW, PORSCHE ETC AT GROFT ON MAY 20TH?

The Saker Challenge with Enduro Cup welcomes you into the series, which features a class for the Sakers and another for GT, Sports and Saloon cars.



2 x HALF HOUR SPRINTS AND 1 x 45 MINUTE ENDURANCE RACE WITH PIT STOP, PER EVENT.
IT IS POSSIBLE TO SPLIT THE RACING AND COSTS WITH ANOTHER DRIVER.

Call 01538 306921

sakercars.co.uk

TO ADVERTISE IN THIS SECTION OF AUTOSPORT PLEASE CALL 0208 267 5865

GINETTA



GINETTA G40R

- Never raced!
- Air Jacks, Passenger seat and harness, Data logging system.
- Ready to go!!

£24,250 + vat

Call John at Mole Valley on: **01306-710088**

RACING CARS



Ginetta G40 Junior race car 2011, Full Ginetta data loga, Gear indicator, 2 race only engine with Very good bhp on factory Dyno, Winter re-build good spares package, 12 wheels, Ready to race.

Phone: 0151 486 7744
Mobile: 07989585186
Email: kj33racer@aol.com
website: www.kelvinjones-motorsport.com

2007 Ferrari 430 GT3 Rosso Scuderia Red

Engine fully rebuilt for 2012
Gearbox fully rebuilt Late 2011
4 sets of wheels
This car has wanted for nothing
Many Pole Position in Britcar 2010
Many race wins in Britcar 2010
Car not used in 2011
British GT GT3b car
Britcar Class 2
GT Trophy
GT Cup
Pirelli Ferrari Open
£79,000
This car is ready to go for 2012
Call Jason 01477 534499



MARKETPLACE

AWNINGS

Grumpygrip Ltd Sales Spares Accessories Custom Printing

Sales Tel: 0800 055 6785
Info@grumpygrip.co.uk

Official UK distributors of the E-Z UP Instant Shelter
The Original since 1983! 1.5m x 1.5m to 6m x 6m Hex.

22 colours - plain or printed - sidewalls - railskirts
Standard colours from stock - next day UK delivery

www.grumpygrip.co.uk

FLOORING

Kiwi Tiles
Interlocking Plastic Floor Tiles, as used by leading race teams throughout Europe.

- ♦ Easy installation & removal
- ♦ Many colours
- ♦ Lightweight
- ♦ Strong & durable
- ♦ Self draining
- ♦ Compact & easy to store
- ♦ Top quality
- ♦ Value for money

Stock Colours:
Red, Blue, Green, Yellow,
Silver, Orange, Grey,
Black, White, Dayglo Red

Ralt Engineering
Tel: 01865 883354 Fax: 01865 883789
E-mail: enquiries@kiwitiles.com
Web: www.kiwitiles.com

FLOORTRAX™
Floortrax™ Race Flooring
Recognised as being the best modular race flooring in the world

- ♦ Co-polypropylene
- ♦ Non-slip
- ♦ Anti-static
- ♦ Takes air jacks
- ♦ Team logo tiles
- ♦ LED lit tiles

Showtrax International Ltd
E: sales@showtrax.net
W: www.showtrax.net
Tel: +44(0)1234 782800

HAMILTON Classic LTD

Specialists in Race & Rally Marquees and Accessories



Swift Shade Instant Race & Rally Marquees

Steel or Alloy frames to suit all budgets. Sizes from 2.2x 2.2 m to 6 m Hexagon From £185 inc vat



Tyre Transport Cases - Tyre Hillclimb Jackets - Indoors & Outdoor Car Covers
Minilite wheels - Motordrive Seats and Much More...

W: www.hamiltongrouponline.com E: office@hamiltonclassic.co.uk T: +44(0)118 973 7300

MEMORABILIA

F1 COLLECTORS .COM

#1 FOR F1 MEMORABILIA
We buy and sell F1 items
AYRTON SENNA specialists
Call CHRIS GRINT 01763 274448
email: sales@f1collectors.com

JMJ Automobilia
SUPPLIERS OF RACE MEMORIBILIA SINCE 1992
Florida, USA (609) 575-1143
email: JM@JMJAUTO.COM
WWW.JMJAUTO.COM

MARKETPLACE

FUEL SYSTEMS

H FUEL PUMPS
REPLACEMENT - UPGRADE - MOTORSPORT



Tel: 01784 493 555
Fax: 01784 493 222
Web: www.fuelsystem.co.uk
Email: sales@glencoeltd.co.uk

£55.00

OTP 017

(P3017.1)

Replaces: Bosch 0580 464 070



£58.00

OTP 018

(P3018.1)

Replaces: Bosch 0580 254 911



£64.00

OTP 019

(P3019.1)

Replaces: Bosch 0580 254 910/941/942



**'IN-TANK'
FUEL PUMPS**

ALL APPLICATIONS ON WEB SITE



PUMPS are:-

High quality, reliable, quiet
• 1yr manufacturers warranty



£65.00

MOTORSPORT

OTP 020

(P3020.1)

Replaces: Bosch 0580 254 909



£75.00

MOTORSPORT

OTP 979

(P3979.1)

Replaces: Bosch 0580 254 979



ALL PRICES EXCLUDE VAT @ 20%

ALFA • BMW • DAEWOO • FORD • FIAT • HONDA • LANCIA • NISSAN • RENAULT • ROVER • VAUXHALL

KARTING



Competitive kart racing on a budget starts here...



Easykart was born over 9 years ago when kart manufacturing giant Birel decided to design a one make category of kart for drivers to get involved in motorsport.

"Easykart is cost effective and simple to maintain - in other words easy!"

The philosophy of **Easykart** is simple, affordable racing with the emphasis on driver ability and fair play. **Easykart** is against cheque book style racing! And remember **Easykart** prices are complete and ready to race – just add fuel! Whether you're 5 years old or 50 years + there is an **Easykart** for you and a complete driving sensation to satisfy any driver.

CLUB100 are the proud promoters of **Easykart** UK and with over 19 years of race management experience have now brought a new dimension to MSA competition racing.

For more information on the **Easykart** format and all of our upcoming events, visit our website at:

www.easykart.co.uk

CLUB100 Racing Ltd, Bon Accord House, Castle Road, Eurolink Commercial Park, Sittingbourne, Kent ME10 3SJ.
Tel: 01795 422455. Fax: 01795 427606.
Email: race@easykart.co.uk



Torque Developments International

Total Performance Solutions

- ESTABLISHED OVER 20 YEARS
- ROAD CAR PERFORMANCE UPGRADES
- RACE CAR PREPARATION AND SUPPORT.
- ECU CALIBRATION AND REMAPPING
- HIGH PERFORMANCE CHASSIS DYNAMICS
- CUSTOM PROJECT DESIGN AND MANUFACTURE
- ENGINE BUILDING AND DEVELOPMENT
- RESEARCH & DEVELOPMENT
- SERVICING AND REPAIRS
- HIGH PERFORMANCE PARTS DISTRIBUTION
- 0% FINANCE ARRANGED

UNIT 5
CLIFFSIDE TRADE PARK
MOTHERWELL WAY
THURROCK
ESSEX RM20 3XD

SALES & GENERAL ENQUIRIES
FREEPHONE +44 (0)800 107 3250
TRADE & DEALER ENQUIRIES
FREEPHONE +44 (0)800 107 3260

WWW.TDI-PLC.COM

prodive
CHASSIS DYNAMICS CERTIFIED

EFI University
Advanced Certification

ata AUTOMOTIVE
TECHNICIAN
ACCREDITATION

MIA
MOTORSPORT INDUSTRY
ASSOCIATION

SAE
INTERNATIONAL®

ISO 9001

beria





Revealed:
The history of
Formula One

Senna

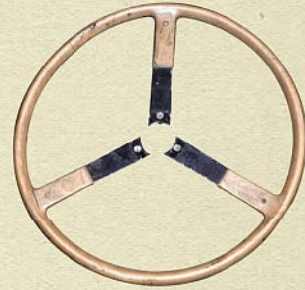

Rindt



Prost



Villeneuve

Mansell



Fangio

Fittipaldi

Hawthorn

Piquet

Hill

Ascari

Clark



Hamilton



Button

Taruffi

FI Collectables • Team Memorabilia • Clothing
Buy • Sell • Evaluations

One of Europe's largest collections

+44 (0)1245 287588 • +44(0) 7771 920345 • sales@finallap.net

www.finallap.net



MARKETPLACE

RACE PRODUCTS

FREE NEW 2012 Motorsport Catalogue

Get Your Copy Now! **demon tweeks**™
MOTORSPORT *Direct*

Calls to 0906 numbers cost 50p per minute at all times.
(Calls should last no longer than 11/2 minutes).

HAVE YOU GOT YOURS YET!

www.demon-tweeks.co.uk Tel: 0906 250 1516



TO ADVERTISE IN THIS SECTION OF

AUTOSPORT

PLEASE CALL
0208 267 5865

London Motorsport Showroom
www.msar.co.uk



msar UK agent for SCHROTH RACING
ORDER HOTLINE: 020 8655 7877

Logitech, Sparco, Schroth, APU, Safety Devices, Aral, Showtrax, TCCETT, BELL, Lifeline

PORSCHESHOP
24-HR • WORLD-WIDE • PARTS-DIRECT

SERVICES: • RESTORATION • MAINTENANCE & DEVELOPMENT
• FULL CHASSIS-UP REBUILDS • TECHNICAL & DIAGNOSTIC

PARTS: • BOXSTER • CAYMAN • TURBO • HISTORIC
• 911 • 968 • 944 • GT3 • RSR • CUP-CAR



COORGE, EBS, SCHROTH, Eibach, Brembo, PAGID, RECARO, K&N, SPAX, Star, Haldex, Performance Friction Brakes, Sabelt, adidas, F, dba

Call Adam or Kevin on: **0121 585 6088**

WWW.REIGERSUSPENSION.COM

The best suspension for:

- Rally
- Rallycross
- Autocross
- Motocross
- Quads
- Sidecar Cross
- Rallye Raid
- Trial



Ninetech, Bilstein, ICEPEAK

REIGER Racing Suspension

Reiger Suspension BV
Molenenk 5a
NL-7255 AX Hengelo Gld.
Tel.: +31 (0)575-462077 Fax: +31 (0)575-463316
info@reigersuspension.com

MARDI GRAS MOTORSPORT
Saloon Car Preparation

Unit 45, Silverstone Circuit
Towcester
Northampton NN12 8TL

tel: 01327 858006 fax: 01327 858800
email: info@mardigras.co.uk
web: www.performanceclutch.co.uk
buy online at www.mardigras.co.uk

Distributors and agents for:

APU RACING FUEL CELLS Celebrating 25 Years Success 1987-2012

STACK STACK

HELIX AUTOSPORT **VDO Performance Instruments** **HYPERCOILS**

VARLEY RED TOP™ THE ORIGINAL RACING BATTERIES **FERODO RACING**

Setrab Pro Line **AP RACING** **Lifeline Fire & Safety Systems Ltd.**

VEVO **PERFORMANCE FRICTION BRAKES**

Eibach SPRINGS **EARL'S PERFORMANCE PRODUCTS** **Castrol**

HONDA **K&N THE WORLD'S BEST AIR FILTER** **SCHRICK**

RACEWEAR

ORIGINAL
Retro - Race Style

MADE IN THE 80s

MEXICO 77

Outlets required

LIVE RACE

www.live2race.co.uk
www.facebook.com/Live2Race.co.uk
twitter@Live2Race

RACE TYRES

AUTOSPORT

MISSED AN ISSUE?
THEN CALL OUR
BACK ISSUE HOTLINE
0844 848 8817

FOR ALL YOUR

AVON
TYRES
MOTORSPORT

RACING TYRES
Inc. ACB 10 Formula Ford
Contact

BMTR LTD

Tel: 0121 331 1122
Fax: 0121 331 1144
email: sales@bmtr.co.uk
see our new web site at www.bmtr.co.uk

RACEWEAR

YB RACING OMP Full range of OMP racewear in our premier EBAY store
AUTHORISED OMP DISTRIBUTOR FIA approved suits for 2012

OMP Entry level Race Suit
DART NEW
only £385 free P&P

COMBO
+ FREE UNDERWEAR SET WORTH £130

OMP First 2 race suit	£312
OMP Dart race suit	£385
OMP Bolt race suit	£440
OMP Dynamo race suit	£548
OMP Technica Plus 2 race suit	£696
OMP One race suit	£875
OMP One Evo race suit	£929

all prices include underwear combo VAT & UK delivery

stores.ebay.co.uk/ybracing

Grand Prix Racewear

RACEWEAR
KARTWEAR
SIMULATION

01327 855 585
WWW.GPRDIRECT.COM

Grand Prix Racewear, Unit 1, Silverstone Technology Park, Silverstone Circuit, Silverstone, Towcester, NN11 8TN

sparco, Arai, BELL, uvex, OMP, CRANFIELD, hans seat

019 RACEWEAR

Evolution Nomex Balaclava
£19.99
Also available in:
Antibes Blue, Red, Charcoal, Denim, Natural

019 Print on the top is also available in these colours:
Antibes Blue, Red, Charcoal, Denim

Evolution Nomex Top
£44.99

Evolution Nomex Pants
£44.99

- All products are totally seamless and manufactured to the highest standard.
- Made in England.
- Stretches to fit and exceptionally comfortable.

Available in Natural only

TO ORDER NOW, CONTACT:
01162 696593 (Open Mon-Fri 9am-5pm)

WEB DIRECTORY

TRAILERS & TRANSPORTERS

RACE & RALLY CARS

MARKETPLACE

APPOINTMENTS

AUTOSPORT

MOTORSPORT JOBS

PUBLICATION DATE EVERY THURSDAY

CALL 020 8267 5820

FOR ALL AVAILABLE VACANCIES PLEASE GO TO THE JOBS SECTION OF AUTOSPORT.COM

BOOKING DEADLINE MIDDAY MONDAY PRIOR TO PUBLICATION

COPY DEADLINE MONDAY 5PM PRIOR TO PUBLICATION

ALL ADVERTS PLACED FEATURE IN THE APPOINTMENTS SECTION OF AUTOSPORT.COM FOR ONE WEEK

RACHEL.BROCK@HAYMARKET.COM

autosport.ads@haymarket.com

Marussia F1 Team have an exciting new permanent vacancy at its Technical Centre in Banbury



Travelling Hydraulic Technician

We have a new vacancy for a hydraulics technician to join our expanding team. This role involves build and servicing of a variety of hydraulic components, fault finding, commissioning, non-conformance reporting and product database management.

Successful candidates will be multi-disciplined technicians, who can demonstrate extensive experience of hydraulic systems within an F1, aerospace or military environment. Preferably educated to HNC level, candidates must be able to understand and interpret detailed engineering drawings and demonstrate excellent fault finding skills. An understanding of data acquisition systems would also be a distinct advantage.

Apply now at
MonsterCoolJobs.com/MarussiaF1Team



LOOKING TO RECRUIT FOR 2012?
THE LATEST SELECTION OF MOTORSPORT JOB
VACANCIES UPDATED EVERY WEEK.

- The appointment page of the website receives on average 200,000 page impressions per month
- The magazine you are looking at has a readership of 144,000 (Source: NRS Survey Q3)
- All appointment adverts placed in Autosport magazine are listed on the website.

Company	Job Title	Application Deadline
Caterham F1 Team	Various Vacancies	3 May 2012
Lotus F1 Team	Various Vacancies	3 May 2012
McLaren Racing	TECHNICAL BUYER & ASSET PLANNER/SUPER	3 May 2012
Oxford & Cherwell Valley College	Various Vacancies	3 May 2012
Red Bull Technology	Various Vacancies	3 May 2012

WHERE ARE YOU ADVERTISING YOUR MOTORSPORT JOB VACANCIES?



Support Team/PR Mechanic

We require an experienced mechanic to support the Company's PR events, as well as attend some race/test events to provide cover, as and when required. You will primarily be responsible for the preparation, assembly and running of our show cars both in the factory and at locations around the world, ensuring they are presented to the highest standards.

To succeed in this role, it is essential that you are an excellent technical problem-solver under pressure and a team player with a strong mechanical background, preferably in Formula One, or another motorsport environment. You should be self-motivated and prepared to travel, with a flexible approach to your work.

To apply, please visit our website at Williamsf1.com and select Race Team, then Williams F1 Team and then Recruitment option under the Team heading.

Closing date: Friday 18 May 2012.



Be a checkered flag winner...
in the classroom.

RESPECT • INNOVATE • INSPIRE

You've enjoyed a fantastic career to date in motorsport. But you've been wondering if or how you can utilise your skills away from the track - less travelling and a better work-life balance.

Here's your chance to teach what you know to young people - the future of the industry - whilst still being in the heart of 'Motorsport Valley'.

Lecturer in Motorsport Engineering • Based Bicester

£17,867 - £20,688 per annum (unqualified)
£22,518 - £32,074 per annum (qualified)

Senior Vocational Trainer - Electrical Installation Based Blackbird Leys, Oxford

£27,678 - £31,142 per annum

So join us, and we'll ensure your career development and ambitions are met, as well as giving you all the support and teacher training you need to be a winner in the classroom too.

For full details, please visit: www.ocvc.ac.uk and go to the 'Working for us' section.

Closing date: 21 May 2012.



a love for learning

OXFORD & CHERWELL VALLEY COLLEGE

Sports Extra

NATIONAL RACING • HISTORICS • CLUB • RALLY • RALLYCROSS • HILLCLIMB



Lynn lapped quickly in FF1600 run at Mallory

F3 aces Lynn and Tincknell to race at Pau historic meet

British Formula 3 frontrunners to use historics for circuit-learning exercise

BRITISH FORMULA 3 RACERS Alex Lynn and Harry Tincknell are set to contest this weekend's Grand Prix de Pau Historique.

The duo, who have both scored F3 podium finishes this season, are racing on the French street track in order to learn the circuit for the following weekend's British F3 round.

YOUNG STARS IN OLDER CARS

While Lynn will contest the Formula Ford 1600 races in a Van Diemen RF81, Tincknell will be out in the Formula Junior field with a Lotus 20.

Tincknell's drive has arisen out of his friendship with ex-Formula Renault team-mate Michael Lyons, whose father Frank owns the Lotus among his stable of historic machinery.

Tincknell said: "It will be the first time I've driven a car older than the old Tatuus Renault! The Junior will be night-and-day different to the F3, but it's worth it to get knowledge of the circuit – my first street track.

"I'm really looking forward to it – it should be a good chilled-out weekend of fun racing."

Lynn's Van Diemen, owned by Steve

Hare, will be run by Maximus Motorsport. He recently had a test in wet conditions at Mallory Park.

Lynn said: "It was torrential rain, but I was only about three seconds off a good dry time. I really enjoyed it, and after I got out I said that's the most fun I've had in a racing car for a long time.

"There'll be no pressure and it will be great fun, especially as my old man [historic ace Shaun Lynn] is racing his AC Cobra in the GT race."

MONACO GATHERS MOMENTUM

Former FIA Thoroughbred Grand Prix champion Bob Berridge will make his single-seater comeback in Monaco's GP Historique a week later.

The historic Group C racer will pilot Chris Perkins' ex-John Watson Surtees TS16 F1 car, run by Mirage Engineering.

Berridge said: "It will be my first time at Monaco. I have tested some Masters F1 cars but last raced a single-seater in BOSS with a Tyrrell 025 over 10 years ago."

Monaco-based Grant Tromans will join the F3 grid with the ex-Michel Ferte Martini Mk81 chassis, while the ex-Enrique Mansilla/Ayrton Senna Ralt RT3 that Richard Eyre intends to race at Monaco was shaken down by Greg Caton at Brands Hatch last week, following its restoration from hillclimb specification.



Ex-Senna Ralt recently had Brands shakedown

AUTOSPORT SAYS...

KEVIN TURNER
FEATURES
EDITOR

kevin.turner@haymarket.com



JUST AS LAST YEAR, THE ASTON Martin Owners Club has made a reasonable start to the season, with solid Intermarque and '50s Sports Car grids at Silverstone last weekend, but this time it really needs momentum. Grids failed to take off in 2011 and Duncan Wiltshire was brought in to help. His task is surely to maintain what is strong (Intermarque) and either discard or revamp what is not, like the pre-1960 and pre-1966 series that didn't work last year.

Wiltshire may be helped by the fact that several motorsport-minded members were voted in at the recent club committee elections. That could heal some of the wounds inflicted by the turmoil of the past few years.

Of more immediate good news for marque fans is Andy Meyrick racing an AMR1 in the Group C event at the Donington Historic Festival this weekend. The ex-works driver flew in father Peter's Spice at the Silverstone Classic last year and should give the more fancied runners (the AMR1 never fulfilled its potential in period) a run for their money.

There will also be sportscars and GTs ranging from the 1920s to 1970s, two touring car series, the Jaguar E-type Challenge, and Historic F2 on show. Wiltshire is involved with this event too. Given that new Donington managing director Christopher Tate sees this branch of the sport as crucial to the track's future, this weekend should be a good one.

Extra contact details

Ben Anderson, national editor
ben.anderson@haymarket.com

CONTENTS

p80 REPORT
750MC BRANDS

p82 REPORT
MSVR/AMOC

p84 REPORT
BHC/BRSCC

p85 REPORT
500MRCI/BARC

Gamble to Formula Renault

Teenager will bring forward single-seater graduation after quitting Ginetta Junior



Gamble leaves Ginettas for single-seaters



GINETTA JUNIOR

refugee George Gamble will make a mid-season switch to Formula Renault BARC this summer after walking out on Ginettas.

Gamble, 15, withdrew from the BTCC-support championship during the second race weekend at Donington Park last month following a disagreement over the category's handling of a multi-car shunt that wrecked his Hillspeed-run G40 (see AUTOSPORT, April 19).

Gamble is currently too young to compete in FR BARC, but will turn 16 in mid-July and will be eligible to contest the final three rounds of 2012 at Croft, Donington and Silverstone.

Gamble will stick with the Hillspeed squad that ran him in Ginetta Junior, and will undertake a test programme before becoming the youngest driver on the Renault BARC grid in the summer.

Gamble said: "We've always wanted to progress into single-seaters and

it's just come a bit sooner than expected. Everything's moved forward so quickly since we took the decision to stop racing in Ginettas.

"As soon as we made the announcement about leaving we had a lot of different offers, but we always wanted to look at Formula Renault BARC and we definitely wanted to stay with Hillspeed – it was the natural choice."

Team principal Richard Ollerenshaw said Gamble's decision

to leave Ginetta Junior had simply accelerated a planned graduation to FR BARC for 2013.

Ollerenshaw said: "With George's decision after Donington it meant we had to look at things again and see how best to get him up to speed for his FR BARC debut in July.

"Looking at this year, how well he's driven on-track, how well he's worked with the team, and how hard he works off-track, we know he'll be very competitive in single-seaters."

RGB

Strong RGB debut for Mittell racer

DOUBLE LOCOST CHAMPION SCOTT

Mittell's new self-built MC51 RGB car made its race debut at Brands Hatch last weekend.

Designed by Scott's father Ian (a retired design-and-technology teacher who raced in FF1600 in the 1980s), the Honda Fireblade-engined MC51 is built around a square tube chassis, stiffened by alloy panels.

The car is all the work of the father-and-son duo, bar specialist water-jet cutting and paint spraying.

It uses conventional outboard double-wishbone suspension with uprights and brakes sourced from a Lotus Elise, and a Quaife differential.



Ex-Locost champ Mittell went well on RGB debut

The combination made a strong race debut at Brands and finished seventh in a very wet race from 13th on the 28-car RGB grid.

Hampshire secondary-school maths teacher Mittell Jr said: "We haven't got on top of the [Yokohama AO48R control] tyres in the wet yet, and went the wrong way on pressures, although we had plenty of grip when we did a dry test at Snetterton."

Single-seaters

Gow hails single-seater talks

MOTORSPORTS ASSOCIATION

chairman Alan Gow believes the first meeting to discuss the state of UK single-seater racing was a success last week, and plans to hold more in the future.

After the failure of Formula Renault UK ahead of this season, Gow called leading figures on the country's single-seater scene to a meeting to discuss the future.

It included representatives from race-organising clubs and certain teams involved with that branch of the sport.

"It was a really good meeting," said Gow. "There were no decisions, but it was a discussion about what

the problems may or may not be and about possible ways forward.

"At the moment I don't know if there is anything we'll do, but it was useful. We will meet again."



Gow was satisfied with the first meeting

MIS Motorsport – setting the standards in motorsport insurance

ON TRACK / ON EVENT / MOTOR TRADE / PERSONAL ACCIDENT / COMMERCIAL / LIABILITY

www.mismotorsport.com or call 01943 884 555

M.I.S. Motorsport Ltd is authorised and regulated by the Financial Services Authority.

MIS
MOTORSPORT



Procter was on form in Ford Focus

European Rallycross

Procter battles to maiden ERC win as Doran suffers a setback

BRITISH DRIVER KEVIN PROCTER

won the second round of the FIA European Rallycross Championship in France last weekend.

The Yorkshireman's maiden ERC win came after he became only the third driver in series history to battle his way from the C Final to the A Final.

The finals were the only races run in dry conditions. Two days of rain at the Circuit de l'Ouest Parisien at Dreux further played into the hands of those with extensive track knowledge, French drivers occupying four of the six A Final grid slots.

Procter qualified his Ford Focus 15th

but led the C Final from start to finish, and progressed to the A by finishing second to Russian Timur Timerzyanov in the B Final, as points leader Tanner Foust parked his Fiesta on lap two.

Former French champion Marc Laboulle and this year's French points leader Jerome Grosset-Janin came to blows in the opening lap of the A Final, allowing Davy Jeanney, another former French national champ, to lead.

Procter rose to second before taking the lead when Jeanney's Citroen C4 failed him. Liam Doran was knocked out at the first corner when his DS3 suffered broken steering.



Renault Clio champ to go competitive jet-ski racing

Triple Renault Clio Cup champion Paul Rivett will make his competitive jet-ski racing debut later this month. The long-time jet-ski enthusiast will ride a 260bhp Rotax-engined jet-ski in the full P1 AquaX Championship.

MARCUS PYE HUMBLE PYE

The voice of club motor racing

F4 newcomer Wauer impressed at Brands

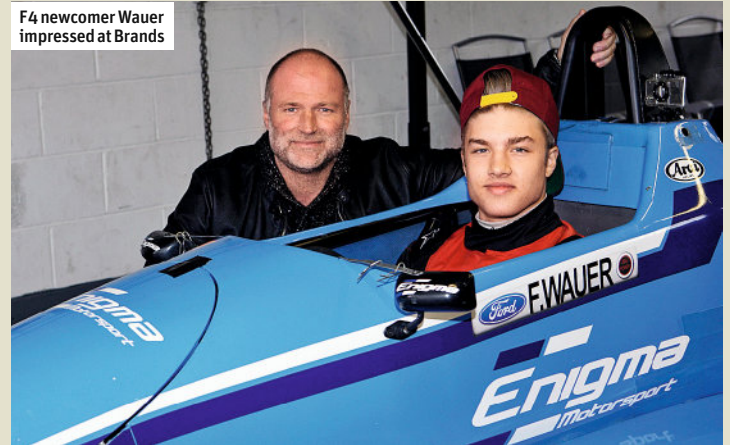

Total mastery of wet conditions is a pretty reliable barometer of ultimate driving ability - who can forget Jacky Ickx's imperious move round the outside of Paddock Bend *en route* to victory in the 1974 Race of Champions at Brands Hatch, or Ayrton Senna's legendary F1 lap at Donington? - but it is rare indeed to see it in young racers. Especially hitherto unknown ones.

Back in 1998, Jenson Button demonstrated extraordinary car control in torrential rain during the McLaren AUTOSPORT BRDC Award trials. That grip-finding gift sealed his accolade. Since then I've not been as impressed with a teenager's car control until last Saturday, when 16-year-old Falco Wauer made his US2000-spec Mygale walk on water at Brands.

Conditions were foul on the Indy circuit, where Wauer (say 'Wower'), born in Sarasota, Florida to an American mother and Norwegian father, won on his UK debut in Formula 4. Forget the status of the achievement (having dropped like a stone at the start from the notoriously fickle cambered pole) that staggered onlookers.

Marshals and photographers also stood open-mouthed as Wauer overtook cars two at a time and, with brake balance wound to the

rear, Scandinavian-flicked his car into Druids. "Brake late, turn late and stay calm," was the ethos of the lad who won the prestigious Margutti Trophy as a junior karter.

Former F4 champion Jeremy Walker, who has taken Wauer under his wing, is not surprised. "Falco's pace stunned me in testing at Rockingham," says Walker. "He also did 46.4s at Brands, 0.4s under the record. He has enormous potential.

"Our plan is to race in F4 and the FFord Eurocup with Enigma Motorsport, then graduate to F2000 in the States next season. Formula 4 is inexpensive, but the cars are sophisticated and relevant to where we are heading."

Wauer adds: "Having raced in Formula Basic [old FFirst cars, in Norway, with desperate reliability] in 2010-11, we have decided to spend this year in the UK, preparing to get on the 'Road to Indy' ladder. The ultimate ambition is to become a professional racing driver."

With abundant talent (even if, like the young Jody Scheckter at Brands, he fell foul of yellow flags in race two having lapped consistently a second quicker than rivals), an engaging personality, a supportive family and connections to RFR manufacturer Ralph Firman through Walker, his dream looks credible.

“Forget the status of the competition, the style of Wauer's achievement staggered onlookers”

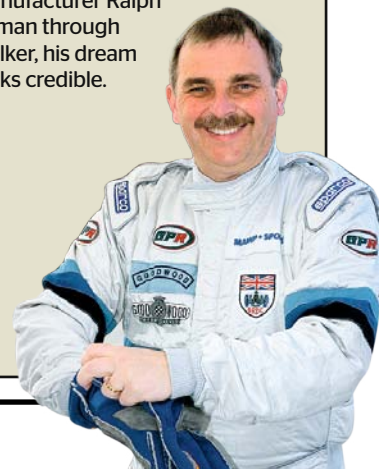

**AUTOSPORT
GOLDEN HELMET**

JUST AS HE DID IN THE early stages of 2011, Ginetta ace Tom Sharp tops our table of race winners in the British Isles after a blistering start to the GT Supercup. Other drivers from TOCA include Michael Meadows and even BTCC star Gordon Shedden - but now they head into hibernation until June. A chance for FVee man Paul Smith or F4/Mono racer Robbie Watts to step up?

POS	DRIVER (CAR/CARS)	O/ALL	CL	TOT
1	Tom Sharp (Ginetta G55)	8	0	8
2	Paul Smith (AHS Dominator)	5	0	5
3	Robbie Watts (Lola F106/03/Van Diemen RAW 01)	5	0	5
4	Matt Bell (Radical SR3 RS)	4	1	5
5	Tom Roche (Mazda MX5 Mk1)	4	0	4
6	Tim Gray (Spire GT3)	4	0	4
7	Gordon Shedden (Honda Civic)	4	0	4
8	Paul Sibley (MG Midget)	4	0	4
9	Paul Corbridge (Toyota MR2)	4	0	4
10	Jason Cooper (Ford Fiesta ST)	4	0	4
11	Michael Meadows (Porsche 911 GT3 Cup)	4	0	4
12	Patrick Havill (Caterham Vauxhall)	4	0	4

Repechage, consolation, 'overflow entry' and handicap races not included. Races/classes must have minimum six starters, and be scheduled for a minimum distance of 10 miles. Overall wins take precedence in the event of a tie, followed by average grid size. For any queries, email us at autosporteditorial@haynet.com



uk



france



sweden



germany



holland



norway

europa's leader in american motorhome rental & sales

Stingray RV is Europe's largest RV dealer with bases in England, France, Sweden, Germany, Holland & Norway.

We are dedicated to supplying luxurious American motorhomes to a varied range of clients for any event, anywhere in Europe.



We are currently taking bookings for all British and European Motorsport events for 2012.

FOR SALE FINANCE AVAILABLE



NEW 30' Winnebago Aspect 30C

Triple slide. Sleeps 5 in 3 beds, cream leather, TV + DVD + Satellite. **£95,000**



2005 36' Monaco Knight

Triple slide, cream leather. Sleeps 6 in 3 beds, 2 TVs+DVD+Satellite, 9,000 miles. **£75,000**



NEW 38' Winnebago Itasca Meridian

Double slide, 1,400 (delivery) miles, air con, sleeps 4 in 2 beds, 2 TVs+DVD+Satellite. Electric awning. **£190,000**



2009 31' Four Winds Hurricane 31D

Double slide, 2 TVs+DVD+Satellite, sleeps 6 in 3 beds. 10,000 miles. **£59,000**

For the finest range of American motorhomes for sale or hire: visit www.stingrayRV.com, call **0870 241 5614** or email simon@stingrayRV.com

www.stingrayRV.com

50,000 square foot of showrooms across Europe



IN BRIEF



Reynolds/Walsh took third win on the trot

NICK ELLIOTT/DAVE PRICE AND

Julian Reynolds/Patrick Walsh each took a third category victory on the trot in last Saturday's Pirelli Historic Rally. Elliott (Ford Escort Mk2) and Reynolds (Mk1) were each peerless in their categories over 50 miles through Kielder forest.

TECHNICAL ISSUES FORCED THE

withdrawal of 2011 British GT champion Jim Geddie's McLaren MP4-12C GT3 from the opening rounds of this year's GT Cup at Donington Park last weekend. The Porsche 997 GT3 of ex-BTCC driver Simon Blanckley also failed to appear.

BRITISH TRUCK RACING CHAMPION

David Jenkins made his VAG Trophy debut in a Mk4 Volkswagen Golf GTI at Donington Park last weekend. He raced with his brother Mark (in a Mk5 GTI) and scored a best result of fifth in race two.

SANDRA HARRISON-MOORE, 37,

died following an accident during the Bognor Regis MC sprint at Goodwood last Saturday. The Milton Keynes woman succumbed to head injuries sustained when her Caterham 7 hit a tyre wall.

IVOR McCULLOUGH'S YOUNGER

brother David made an impressive race debut at Kirkistown last Saturday. Armed with an ex-Charlie Donnelly Van Diemen RFOO, McCullough Jr took fourth in the FF1600 qualifier before going on to finish fifth in the inaugural SuperSeries race.

MICK GRANT TWICE FINISHED

second on his race debut in the Sport Specials/SRGT Challenge races at Brands Hatch last weekend. The sole starter in the Tiger Cars class also led much of Sunday's stanza in his Ford Duratec-powered machine.

RICHARD CHAMBERLAIN SHOWED

his CTR Arachnid coupe's pace in last Sunday's 750MC Bike Sports season opener by leading former champion Richard Stables's Radical PR6 before suffering problems. The ex-Porsche 935 clone racer shared it with son Matthew.

Suzuki Hayabusa-engined Arachnid was fast



Group C/GTP

Meyrick to race AMR1

Sportscar ace in Group C
Aston for Donington



Top Aston AMR1 at Le Mans in 1989 was 11th

FORMER ASTON MARTIN FACTORY driver Andy Meyrick will race one of the British sportscar maker's famous cars in the first round of the Group C/GTP series at Donington Park this weekend.

The 26-year-old Briton, who raced for Aston Martin Racing in 2010-11, will drive Paul Whight's 1989 Group C AMR1 in the series opener, which is part of the Donington Historic Festival. This means he will have driven both last year's ill-fated AMR-One LMP1 and its near-namesake, which was the previous

ground-up Aston prototype design.

Meyrick, who won the Group C2 division of the series last year with father Peter, said: "It makes for a nice story, and I'll probably end up being the only person to drive both cars."

"Paul asked me out of the blue if I had a free weekend. I was up for it. I'm going to be driving the car on my own and I'm going to give it a go."

Group C/GTP has attracted a 22-car grid for Donington, which includes the Sauber-Mercedes C9 that won the 1989

World Sports-Prototype Championship fixture at the British track. Gareth Evans purchased the car last winter from Australia and plans to race it on occasion with the Chamberlain-Synergy team this year.

British Le Mans legend Alain de Cadenet will contest his first race at Donington Park in more than 20 years when he shares Mark Knopfler's AC Ace in the Pre-63 GT race at the Historic Festival. The former sportscar entrant and driver tested the car last Thursday.

AMOC

Positive first '12 meet for AMOC



Wiltshire wants more owners' club races

THE ASTON MARTIN OWNERS Club held a successful first meeting of 2012 at Silverstone last weekend, having brought in promoter Duncan Wiltshire to help revitalise its ailing grids over the winter.

AMOC brought together 21 cars for the Intermarque Championship race, a figure that would have been higher had it not been for four cars suffering damage in the rain during testing on Friday. Numbers were also strong in Equipe GTS and the '50s Sports Cars categories.

Wiltshire intends to consolidate

grids and encourage close racing in 2012, but also hopes to work with other owners' clubs to gain numbers.

"I was pleased with the first meeting of the year," said Wiltshire. "AMOC has been struggling in recent seasons but there was a sense of optimism in the paddock."

"We had close racing at Silverstone and I hope to consolidate the grids this year. I don't want to be overambitious, but grids of 20 to 25 cars are achievable.

"We want to grow and we are looking at working with other clubs."

Electric racing

Polish uni wins electric enduro

THE SILESIA UNIVERSITY OF Technology from Poland claimed first and second places in the 2012 Greenpower Corporate Challenge at Silverstone last Sunday.

The four-hour electric-only endurance event, which was founded in 2008, is open to teams of three drivers and six mechanics. The Polish university is the first international entrant to have competed in the challenge, which had 32 teams racing on a soaking Silverstone National circuit. Fifteen were school teams, the highest placed of which finished fourth.

Other notable entrants included Jaguar Land Rover and Peugeot Citroen, where graduate and apprentice teams developed and built their entries.

The winning team covered 45 laps of the track in 2h40m using 15p-worth of electricity in a weather-shortened race.



Winning team used 15p-worth of electricity



Guy Hefford (50) controlled race one from the front

750MC BRANDS HATCH, APRIL 28-29

Wauer wows 'em with F4 debut win



Wauer was imperious in the wet in Formula 4

“DID NOBODY TELL him it was raining?” asked marshal/racer Chris Salt after 16-year-old American-Norwegian Falco Wauer trounced top Formula 4 opposition on his UK racing debut.

Comfortably inside Robbie Watts' lap record in Friday testing, Wauer also excelled in Saturday's monsoon, but getting the ex-Jonathan Weston-Taylor Mygale off pole proved tricky.

Twice he was swallowed by the pack in the restarted opening race – “I let the clutch out too fast and the motor stopped,” he shrugged – but the recoveries were sensational. Having deposed leader Watts, the youngster displayed phenomenal car control as he stormed to victory.

The action replay plan went wrong when Wauer ousted Watts under waved yellow flags and was excluded. “He's good, but that was naughty,” said Watts, who reckoned he'd not been as wet in 20 years of racing at Brands.

Tim Gray again blitzed RGB, but four Spires in the top six made it a red letter Saturday for marque founder Paul Nightingale, especially since novice Matt Higginson finished second in his ex-works GTR. John Cutmore led Gray briefly in Sunday's dry race, before Tim knuckled down and smashed another lap record. Paul Rogers (Contour) and Derek Jones (Sabre) were third and fourth, with Tony Gaunt's new Wolfe sixth.

Silverstone Stock Hatch double winner Joe Ferguson's weekend looked doomed when his Citroen Saxo was spat out of the pack on the descent from Druids on lap one of Saturday's race, smote the tyre wall, bucked into the air and ricocheted back into the pack. Incredibly, he fought back to third behind Jake Farndon and Patrick Fletcher as Saxmax alumni claimed the top four places.

After several exchanges with Fletcher in a frantic first half of lap six,

Ferguson – who had passed Andy Tibbs and Tom Bell before catching the defending champion – aced Sunday's race.

Farndon, his win ballast no handicap once he'd got going, clawed back up to second, ahead of Fletcher.

Fiesta XR2i drivers Lee Scott and Andrew Thorpe claimed Classic Hatch honours. Scott beat Vauxhall Nova man Damian Cottrell (who had grabbed the lead under yellow flags at Paddock)

in race one, while Thorpe headed home Derek Rozier's fast Peugeot 205GTi in the sequel.

The top-value BMW E36 Compact Cup has trebled in size over the winter. Beemer specialist Robin Welsh appeared late for the series opener, thus was obliged to start from the pitlane (“I was playing mind games with rivals but they bit me”), but he shot to third behind Stock Hatch convert Alex Dew and a surprised Colin

Bysouth in his first race!

Welsh arrived more snappily second time out and powered his 318i almost 25 seconds clear of David Power, Kevin Denwood and Stuart Voyce.

In Saturday's bitterly cold weather Sam Oliveira's Sheane split its oil cooler and an hour was lost mopping up in pouring rain before a restart. Paul Smith continued his winning run, although second-placed Keith Farrance lapped quicker. Smith's AHS



BMW grid has trebled in size

“Brake late, turn late and stay calm”

F4 winner Falco Wauer's secret to wet-weather driving



Rozier leads Scott and Thorpe



Ferguson (34) crashed on the first lap but took third!

Dominator conked out on Sunday after leading and Farrance pitted, so Oliveira rewarded car owner Dave Jordan's engine change with a masterful win over AUTOSPORT's Ben Anderson. "I was sliding it, but my car was on rails," grinned a soggy Oliveira. Team-mate Ian Jordan survived a hairy gyration to win class B.

The Locosts were sieved into three groups, each racing the others. Richard Jenkins won Saturday's wet races from Michael Comber and Stuart Sellars respectively. Sellars pipped Alex von Ehrheim on Sunday after Lee Bankhurst and Mark Draghicescu clattered into the gravel.

Unfazed by rain, Cheng Lim blasted his RAM Cobra to Sport Special/SRGT glory on Saturday, chased by debutant Mick Grant's 250bhp Ford Duratec Tiger. Unfathomably, Cheng

chose wet tyres on a fast-drying track on Sunday. Once he'd fried them he was easy meat for Clive Hudson's Duratec-engined Eclipse, early leader Grant and David Caldecourt's Sylva Phoenix-Zetec.

Guy Hefford did not buckle under pressure from George Robinson in the first Toyota MR2 encounter.

Paul Hinson made it three from four in the finale, helped by most of his pursuers having excursions. Hefford's trip though the gravel led to retirement, leaving Robinson and Michael Wells, who was ecstatic with his first podium, to chase Hinson to the flag.

Adrian Reynard led most of the Bike Sports series opener having passed Mike Field's Stohr at Druids, but his Inverter lost oil and Field pounced into Surtees on the penultimate lap.

With Reynard out, Field screamed clear of James Breakell's Radical PR6 in the return match. A fuelling issue – "I had to waggle the steering from side to side to make it pick up" – on the final lap slashed Field's lead from six seconds to a length.

Owen Hunter won Saturday's eight-car Saxmax bout to maintain this term's unbeaten record. Guy Wenham beat him to Sunday's chequer only for a jump-start penalty to drop him back – a harsh blow since Hunter seized the lead by sweeping round the outside of Hunter and Mikey Day at Surtees half a lap later!

Paul Gorolini outran Don Rawson and spinner Ron Welsh for 750 Trophy victory. Dane Christian Pedersen drove his exquisite Austin 7 monoposto to a class win.

● Marcus Pye

750 FORMULA BRANDS HATCH, APRIL 28-29

Sheppard commands his flock at Brands

THE 750 FORMULA race on Sunday was a wonderful advert for Britain's oldest club championship (first won by Charles Bulmer in 1950, driving an ex-works Austin 7 Ulster) and the spirit of its combatants.

Second on Saturday to defending champion Nathaniel Cooper, Max Sheppard scored a brilliant maiden victory in the car he designed himself, and built with help from father Barry (of Rawlson fame).

Sheppard got out of the blocks cleanly on a slick track and repelled attacks from Cooper (Davis T7) and 2010 champ Roger Rowe (Centaur Mk16).

Cooper spun twice, the first at high speed through Surtees, but never gave up, even after he was blocked by veteran Dick Hartle (Tristesse) all round the Clearways loop.

Rowe got within 0.15s of Sheppard, but a monster moment at Clearways left an elated Sheppard clear. "I've not done this before," said Max as the magnitude of his achievement sank in.

The four former champions who finished behind Sheppard offered warm congratulations, and Billy Albone's first top-six placing in the improving Batten 3 was cheered too.

● Marcus Pye

750 FORMULA (9 LAPS)

1 Nathaniel Cooper (Davis T7); 2 Max Sheppard (MS750/01) +0.66s; 3 Bob Simpson (SS/Fiat); 4 David Facer (Mallock U2 Mk16); 5 Martin Kemp (Racekits Falcon); 6 Roger Rowe (Centaur Mk20MC). **CW Facer.** FL Cooper 1m04.10s (67.34mph). **RACE 2 (13 LAPS)** **1 Sheppard;** 2 Rowe +1.15s; 3 Cooper; 4 Simpson; 5 Dave Robson (SDAR/CW); 6 Billy Albone (Batten 3). **CW Albone.** FL Cooper 1m03.67s (67.79mph).



Sheppard (71) leads Cooper (97) into Paddock

FORMULA 4 (12 LAPS) 1 Falco Wauer (Mygale US2000); 2 Robbie Watts (Van Diemen RAW01) +176s; 3 Daniel Hands (Van Diemen RF10); 4 Shane Kelly (Tatuus FR); 5 Bryn Tootell (Van Diemen RF09); 6 James Harris (Mygale SJ00). **Class winner** Erwin Smiech (Reynard SF84). **Fastest lap** Wauer 5597s (7712mph). **RACE 2 (7 LAPS)** 1 Watts; 2 Hands; 3 Kelly; 4 Harris; 5 Smiech; 6 Damon Bland (Van Diemen RF98). **FL Watts** 58.42s (73.89mph). **RGB (10 LAPS)** 1 Tim Gray (Spire GT3); 2 Matthew Higginson (Spire GTR) +2.68s; 3 Derek Jones (AB Sabre); 4 John Cutmore (Spire GT3); 5 Paul Rogers (Contour RGB09); 6 Mathew Green (Spire GT3). **CW Alastair Boulton (STM Phoenix).** FL Gray 1m06.24s (65.16mph). **RACE 2 (17 LAPS)** 1 Gray; 2 Cutmore +15.02s; 3 Rogers; 4 Jones; 5 Gary Goodyear (Contour RGB11); 6 Tony Gaunt (Wolfe TG02). **CW Boulton.** FL Gray 49.53s (87.15mph) **record.** **STOCK HATCH (13 LAPS)** 1 Jake

Fardon (Citroen Saxo VTR); 2 Patrick Fletcher (Saxo) +14.26s; 3 Joe Ferguson (Saxo); 4 Andrew Tibbs (Saxo); 5 Nick Thornton-Jones (Saxo); 6 Rory Cooper (Saxo). **FL Fardon** 1m05.04s (66.37mph). **RACE 2 (13 LAPS)** 1 Ferguson; 2 Fardon +1.83s; 3 Fletcher; 4 Tom Bell (Saxo); 5 Tibbs; 6 Thornton-Jones. **FL Fardon** 1m06.28s (65.12mph). **CLASSIC HATCH (10 LAPS)** 1 Lee Scott (Ford Fiesta XR2i); 2 Damian Cottrell (Vauxhall Nova GTE) +1.77s; 3 Andrew Lightfoot (XR2); 4 Edward Cooper (Nova); 5 Paul Thorpe (XR2i); 6 Andy Philippotts (XR2i). **FL Matt Rozier (Peugeot 205GT1)** 1m09.04s (62.52mph). **RACE 2 (6 LAPS)** 1 Thorpe; 2 Rozier +0.33s; 3 Lightfoot; 4 Philippotts; 5 Cooper; 6 Scott. **FL Thorpe** 1m08.14s (63.35mph). **BMW COMPACT CUP (13 LAPS)** 1 Alex Dew; 2 Colin Bysouth +1.06s; 3 Robin Welsh; 4 Stuart Joyce; 5 Andrew Tsang; 6 Kevin Denwood. **FL Bysouth** 1m05.78s (65.62mph). **RACE 2 (15 LAPS)** 1 Welsh; 2 David Power +24.39s; 3 Denwood;

4 Joyce; 5 Tsang; 6 Ryan Bensley. **FL Welsh** 58.28s (74.09mph) **record.** **FORMULA VEE (7 LAPS)** 1 Paul Smith (AHS Dominator); 2 Keith Farrance (GAC) +1.48s; 3 Ben Anderson (GAC); 4 Jake Oliveira (Storm); 5 Ben Miloudi (Ray Bowles); 6 Gareth Evans (Scarab Mk2). **CW Evans.** FL Farrance 1m05.43s (65.97mph). **RACE 2 (12 LAPS)** 1 Sam Oliveira (Sheane Jenvee); 2 Anderson +8.84s; 3 William Foster (GAC); 4 Miloudi; 5 Ian Jordan (Sheane Jordan); 6 Peter Belsey (Spyder Mk2). **CW Jordan.** FL Oliveira 1m06.32s (65.08mph). **LOCOST GROUPS B & C (10 LAPS)** 1 Richard Jenkins; 2 Michael Comber +2.98s; 3 Alex von Ehrheim; 4 Lee McNamara; 5 Mark Draghicescu; 6 Nick Selby. **FL Comber** 1m09.49s (62.12mph). **C & A (9 LAPS)** 1 Jenkins; 2 Stuart Sellars +1.17s; 3 Lee Bankhurst; 4 Stephen Kimber; 5 Comber; 6 Alastair Garratt. **FL Jenkins** 1m08.71s (62.82mph). **A & B (12 LAPS)** 1 Sellars; 2 von Ehrheim +0.12s; 3 Steven Wells; 4 Selby; 5 Matt Cherrington;

6 Anthony May. **FL 1m09.28s** (62.30mph). **SPORT SPECIALS/SRGT (9 LAPS)** 1 Cheng Lim (RAM Cobra); 2 Mick Grant (Tiger) +12.76s; 3 David Caldecourt (Sylva Phoenix); 4 Clive Hudson (Eclipse SMI); 5 Barry Sheppard (Nomad 1A); 6 Paul Richardson (Lotus 23R). **CW Caldecourt.** Sheppard; Richardson; Robert Frost (DAX Tojeiro). **FL Lim** 1m04.02s (67.42mph). **RACE 2 (15 LAPS)** 1 Hudson; 2 Grant +4.64s; 5 Caldecourt; 4 Lim; 5 Stephen Lansley (Procomp LA Gold); 6 Paul Boyd (Eclipse SMI). **CW Caldecourt.** Lim; Paul Taberner (Westfield SEW); Robert Bennett (MEV Rocket). **FL Hudson** 53.55s (80.61mph). **TOYOTA MR2 (14 LAPS)** 1 Guy Hefford; 2 George Robinson +0.51s; 3 Matthew Palmer; 4 Paul Hinson; 5 Stuart Nicholls; 6 Luke Austin. **CW Nicholls.** FL Hefford 59.88s (72.08mph). **RACE 2 (15 LAPS)** 1 Hinson; 2 Robinson +3.05s; 3 Michael Wells; 4 Palmer; 5 Ben Rowe; 6 Connor Hambleton. **CW Nicholls.** FL Hefford 57.63s (74.90mph) **record.** **BIKE SPORTS (20 LAPS)** 1 Mike Field

(Stohr DSR); 2 Adrian Reynard (Reynard Inverter) +2.26s; 3 James Breakell (Radical PR6); 4 Richard Stables (Radical PR6); 5 Oliver Cox (Radical SR4); 6 David Watson (Radical PR6). **CW Cox.** FL Field 55.96s (77.13mph). **RACE 2 (24 LAPS)** 1 Field; 2 Breakell +0.15s; 3 Stables; 4 Cox; 5 Iain Cumming (Speads RS06D); 6 Richard Hardie (Radical SR4). **CW Cox.** FL Field 46.81s (92.21mph). **SAXMAX (8 LAPS)** 1 Owen Hunter; 2 Mikey Day +9.46s; 3 Guy Wenham; 4 Sam Morgan; 5 George Streater; 6 Michael Higgs. **FL Hunter** 1m08.27s (63.23mph). **RACE 2 (14 LAPS)** 1 Hunter; 2 Wenham +3.68s; 3 Day; 4 Morgan; 5 Streater; 6 Higgs. **FL Wenham** 1m00.15s (71.76mph). **750 TROPHY (11 LAPS)** 1 Paul Gorolini (JB); 2 Don Rawson (Rawson-Climax) +6.66s; 3 Ron Welsh (Fairthorpe FJ); 4 Lyndon Thruston (DNC); 5 Christian Pedersen (Austin 7 Monoposto); 6 Malcolm Hills (Austin 7 Special). **CW Pedersen.** FL Gorolini 1m16.64s (56.32mph).



GT CUP DONINGTON PARK, APRIL 28-29

Wins to Aquila, Nissan and Ferrari in GT Cup

BOB BERRIDGE, BENJI Hetherington and Derek Johnston each claimed a GT Cup victory at Donington.

The experienced Martin Short had put his Mosler Super GT on pole for the opening race, but when the red lights went out it was Johnston who led in his Ferrari 458 GT3. Johnston, Berridge (in a rare Aquila CR1) and Short were soon engaged in a hard fight, well clear of the rest of the field.

Berridge was fully occupied fending off the close attentions of Short as they sped into Redgate on the third lap, but soon found himself in the lead.

Berridge was uncatchable, while Short claimed second on the fifth lap by going around the outside of

Johnston at Redgate. “When you’re down on power you have to pick your moments,” said Short after the race.

With main-bearing problems sidelining the Aquila, Short took an early lead in the second race before Johnston’s Ferrari swept ahead at Goddards.

But a spin for the 458 exiting Redgate on lap two left Hetherington’s Nissan GT-R chasing Short. He settled it by passing the Rollcentre Racing Mosler on the sixth lap.

Johnston had a brilliant opening lap next time out and emerged ahead of Nick Whale and Short.

After Short usurped Whale the contest boiled down to a scrap between the



JMH Nissan leads Rollcentre Mosler

Ferrari and Mosler.

Short closed as the rain became heavier, but to no avail as Whale finished a distant third.

● Graham Read

RESULTS (20 LAPS) 1 Bob Berridge (Aquila CR1); 2 Martin Short (Mosler Super GT) +7.622s; 3 Derek Johnston (Ferrari 458 Challenge);

4 Freddie Hetherington (Nissan GT-R GT3); 5 Kevin Riley (Mosler MT900GT); 6 Michael Saunders (TVR Cerbera). **Class winners** Peter Smallwood (Porsche 997 GT3); Lee Mowle (Ginetta G50). **Fastest lap** Berridge 1m06.741s (106.75mph).

RACE 2 (17 LAPS) 1 Benji Hetherington (Nissan GT-R GT3); 2 Short +15.049s; 3 Harry Whale (Porsche 997 GT3); 4 Dan

Stringfellow (BMW E46 M3); 5 Mowle; 6 Chris Bentley (Porsche 996). **CW** H Whale; Mowle. **FL** Hetherington 1m27.138s (81.76mph).

RACE 3 (18 LAPS) 1 Johnston; 2 Short +0.977s; 3 Nick Whale (Porsche 997 GT3); 4 Mowle; 5 Riley; 6 Jordan Witt (Chevron). CW N Whale; Mowle. **FL** Johnston 1m21.492s (87.42mph).



Stuteley thrashed F3 Cup opposition

F3 CUP DONINGTON PARK, APRIL 28-29

Stuteley gives the rest an F3 masterclass

WITH OPENING-ROUND double winner Jamie Stanley absent and unlikely to compete again this year, a new winner was guaranteed in the F3 Cup. Linton Stuteley obliged twice and with great style.

The conditions before the first encounter were very challenging, but Enigma Formula Ford team boss Stuteley revelled in them to take a dominant pole position in qualifying.

Come the start of race one he sprinted his Dallara

F399 into an immediate lead ahead of the pursuing F306 of Mark Harrison.

Harrison could not live with the leader’s pace though and started to fall behind, before a spin for Stuteley allowed Harrison to take the lead on the fourth lap of nine.

But Stuteley reasserted his authority, with Harrison running second ahead of Chris Dittmann and Tristan Cliffe.

The race was then red-flagged when Harrison

became stranded at Goddards, leaving a podium trio of Stuteley, Dittmann and Cliffe.

Stuteley started from pole again in the second race and his performance was a masterclass in how to drive in abysmal weather.

The Whittlesey-based driver immediately started to leave the pack behind and by the chequered flag he had pulled out 53 seconds over reigning Mono 2000 champ Cliffe in just 15 laps.

Gino Ussi completed the podium trio after holding off Dittmann.

● Graham Read

RESULTS (9 LAPS) 1 Linton Stuteley (Dallara F399 Opel Spiess);

2 Chris Dittmann (Dallara F301 Renault) +6.561s; 3 Tristan Cliffe (Dallara F307 Toyota); 4 Gino Ussi (Dallara F307 Mercedes HWA); 5 Benjamin Harvey (Dallara F307 Mugen Honda); 6 Dave Karaskas (Dallara F300 Opel Spiess).

CW Cliffe; James Ledamun (TOM’S 036F Toyota). **FL** Stuteley 1m21.410s (87.51mph). **RACE 2 (15 LAPS) 1 Stuteley; 2 Cliffe +53.863s; 3 Ussi; 4 Dittmann; 5 Mark Harrison (Dallara F306 Mugen Honda); 6 Harvey. CW** Cliffe. **FL** Stuteley 1m17.630s (91.77mph).

VAG TROPHY DONINGTON PARK, APRIL 28-29

Wars of the Rose’s

REIGNING CHAMPION Daniel Rose made a poor start from pole in the first VAG Trophy race of 2012, but led again when those who swept ahead hit trouble at Redgate.

Ken Lark’s Corrado was on his tail before cars beached at Craner Curves brought out the safety car. Later, Lark and Paul Taylor tracked Rose to the flag.

The following day the conditions were cold and wet, but Rose overcame them for another victory.

Tony Absolom, who failed to finish race one, beached his Golf in the

gravel, so Paul Taylor inherited second before Joe McMillan usurped him on lap seven of 10.

● Graham Read

RESULTS (9 LAPS) 1 Daniel Rose (SEAT Leon Cupra R);

2 Ken Lark (VW Corrado VR6) +2.629s; 3 Paul Taylor (VW Golf R32 Mk5); 4 Joe McMillan (SEAT Leon Cupra R Mk2); 5 Mark Jenkins (VW Golf GTI Mk5); 6 Rob Allum (SEAT Ibiza 1.8T). **CW** Allum. **FL** Rose 1m20.190s (88.84mph).

RACE 2 (10 LAPS) 1 Rose;

2 McMillan +31.916s; 3 Taylor; 4 Allum; 5 David Jenkins (VW Golf GTI Mk4); 6 Keith Davies (VW Mk5 Golf R32). **CW** Allum. **FL** Rose 1m34.430s (75.44mph).



VAG Trophy gets underway



Wright leads Mono Moto rivals through Donington gloom

ASTON MARTIN GT4 CHALLENGE SILVERSTONE, APRIL 28

Bouche/Mantello beat Black at a soggy Silverstone



Bouche/Mantello starred in GT4

THE ASTON MARTIN GT4 Challenge season began at a very wet Silverstone and it was the machine of Pierre Mantello and Olivier Bouche that performed best in the difficult conditions.

They laid down a marker in qualifying, beating the next quickest car of Chris

Kemp/Stuart Hall by over half a second.

The polewinners used their advantage to establish a lead of nearly 20 seconds in just 10 laps.

Behind was a close fight between Phil Dryburgh and Paul Bartley as Kemp dropped down the order.

The big winner in the

mandatory pitstops was Tom Black. He pitted on consecutive laps and, once all the stops had finished, he found himself running third. He soon overtook Aston Martin chairman David Richards, who shared with Dryburgh.

Black set about catching the leader. He closed

up considerably, but couldn't quite launch a late bid for victory.

The race for third came alive after Richards spun at Copse and was passed by the Bartley/Stuart Patterson car.

Just when Richards closed back in, he spun again and had to settle for fourth.

He enthused: "It was very slippery and bravado got the better of me, but it was great fun!"

● Stephen Lickorish

RESULTS (78 LAPS) 1 Olivier

Bouche/Pierre Mantello (GT4);

2 Tom Black (GT4) +11.261s;

3 Paul Bartley/Stuart Patterson

(N24); 4 Phil Dryburgh/David

Richards (GT4); 5 Chris Kemp/

Stuart Hall (GT4); 6 Kenneth

Greenberg/Andreas Kramer (GT4).

CW Nicholas King (DB4 LW).

FL Hall 1m06.029s (89.43mph).

AMOC INTERMARQUE SILVERSTONE, APRIL 28

Kearney's Ferrari wins as main rivals all hit trouble

IT WAS FERRARIS, not Aston Martins that dominated this encounter as Prancing Horses claimed the top three places.

John Bussell/Conor O'Brien's Aston DB4 led the early stages after starting from pole, ahead of the similar machine of Martin Melling/Peter Snowdon.

But both Astons hit problems later on as Melling struggled with rain tyres on a drying track and the other DB4 had to pit when its door came open.

It looked like Wayne Marris's Ferrari 355 would win, but he spun, collected a backmarker and dropped to third with just two laps left.

This allowed Vance Kearney to claim victory after on-the-road winner Tony Greatorex was excluded for not pitting.

● Stephen Lickorish

RESULTS (38 LAPS) 1 Vance

Kearney (Ferrari 355); 2 David

Ingram Hill (Ferrari 355 Challenge)

+7.106s; 3 Wayne Marris (Ferrari

355); 4 Nicholas King (Aston Martin

DB4 Lightweight); 5 James Neal/

Neil Harvey (Porsche 964); 6 Conor

O'Brien/John Bussell (Aston Martin

DB4 Lightweight). **CW** King; Neil/

Harvey; Tristan Bradfield (Sunbeam

Tiger); Malcolm Jones (Porsche

911); William Smalldridge (MG

Midget). **FL** Steven Byrne/Jeremy

Bailey (Aston Martin N24)

1m07.835s (87.05mph).



Eastwood took his third Ferrari Open win

FERRARI OPEN SILVERSTONE, APRIL 28

Eastwood's run goes on

THERE WERE PLENTY of surprises in the Ferrari Open race, not least when Nils-Fredrik Nyblaeus's Austin Healey mistakenly entered the fray for a couple of laps!

Of the expected competitors for this race, Gary Eastwood continued his great start to the season as he made it three wins in three races in his 458 with a lights-to-flag victory, ahead of Sam Smeeth's 430.

It looked like Mick Dwane would take third until, with just two laps

left, he received a puncture in an incident with a backmarker. Therefore Toby Tarrant-Willis finished third, despite starting last having spun off in the treacherous qualifying conditions.

● Stephen Lickorish

RESULTS (23 LAPS) 1 Gary

Eastwood (458); 2 Sam Smeeth

(430) +13.069s; 3 Toby Tarrant-

Willis (430); 4 Wayne Marris (360);

5 Jacques Duyver (430); 6 Paul

Bailey (458). **CW** Smeeth; Vance

Kearney (F355); Paul Brooks (456

GT); David Hathaway (360). **FL**

Eastwood 1m04.698s (91.27mph)



Late clash for Marris (60) handed win to Kearney

IN BRIEF



Watts turned up late but won race two

MONO 2000/CLASSIC

Malcolm Scott proved invincible in race one at Donington, as he left 2011 champion Peter Venn as best of the rest. Robbie Watts missed that race to compete in F4 at Brands, but took his third victory of the season in race two.

RADICAL CLUBMANS CUP

Two wins for Matt Bell at Donington made it four from four starts this season. In the opening race Mark Abbott set the early pace before Bell slipped by. Later on Bell had to resist intense pressure from Bradley Smith.

MONO 1800/1600/MOTO

Marc Fortune (Jedi) stayed out of trouble to win race one at Donington, while chaser Jason Timms retired after clashing with a backmarker. Adrian Wright took his first win of the season in a wet race two, clear of Nigel Davers.

FERRARI CLASSIC

The wet conditions at Silverstone caught out Danny Winstanley as he spun exiting Woodcote on lap two and hit the pitwall. This allowed David Tomlin to win fairly comfortably in his 308GTB.

'50s SPORTS CARS

This Silverstone race featured a tremendous dice between Mike Thorne's Austin Healey and John Burton's Jaguar XK120 for the win. The lead changed numerous times, but eventually the Jaguar's grunt won out by 1.2 seconds.

EQUIPE GTS

There was a three-way battle for the win on a drying Silverstone track, after early leader Keith Ahlers hit mechanical trouble. Backmarkers conspired against Pete Foster's and John Andon's Triumphs, allowing Richard Plant's Morgan to win.



Plant's Morgan prevailed



BRITISH HILLCLIMB CHAMPIONSHIP PRESCOTT, APRIL 29

Menzies and Adams beat champ in opening battle

THE FIRST EVENT OF 2012 brought a pair of Scottish winners in Wallace Menzies and Lee Adams. Last year's top two of Scott and Roger Moran also piled in with their usual consistency, with Moran Jr matching Menzies for overall points and his father Roger close behind. Menzies benefited from a superior traction-control set-up, giving the DJ its unique soundtrack in addition to his undoubted skills. Adams was hampered by a lack of full-wet tyres in the early torrential weather, but well-used intermediates sufficed later on.

"This is my best-ever start and I'm confident there is much more to come," reckoned Menzies.

Adams was a little subdued after enduring a difficult week. Most of his car's mechanical parts had to be fitted to Jos Goodyear's not-yet-completed machine after an off by Goodyear the previous weekend at Doune damaged the carbon tub.

After a spin in run-off one, Trevor Willis came back to snatch second later on, while reigning champion Scott Moran secured a second and a third.

In sensational form was uni student Alex Summers in his father's relatively old OMS, fitted with a mere 1000cc of Suzuki GSXR power. His fourth and eighth left him tied with Adams in the points table. ● Eddie Walder



Menzies took victory and early title lead

ROUND 11 Wallace Menzies (3.2 DJ Firestorm Cosworth) 45.79s; 2 Scott Moran (3.5 Gould GR6IX NME) 46.68s; 3 Roger Moran (3.5 Gould GR6IX NME) 46.70s; 4 Alex Summers (1.0 OMS CF Suzuki) 47.81s; 5 Mike Manning (2.0t Ford Puma Cosworth) 48.08s; 6 Richard Spedding (1.6 Force PC Suzuki) 48.09s; 7 Tom New (Gould GR55 Judd) 48.51s; 8 Will Hall (3.5 Force WH Nissan) 48.59s; 9 Graham Wynn (1.6 Force LM Suzuki) 51.18s; 10 David Uren (1.6 Force PC Suzuki) 51.76s; John Bradburn (3.5 Gould GR55 Cosworth)

fail; Trevor Willis (3.2 OMS 25 Powertec) fail. **ROUND 21 Lee Adams (1.6 GWR Raptor Extreme) 43.82s BTD;** 2 Willis 43.99s; 3 S Moran 44.03s; 4 Menzies 44.26s; 5 R Moran 45.10s; 6 Jos Goodyear (1.6 GWR Raptor Extreme) 45.72s; 7 Hall 46.03s; 8 Summers 46.16s; 9 Bradburn 46.49s; 10 Spedding 46.52s; 11 New 46.79s; 12 Tony Wiltshire (3.5 Gould GR55 Cosworth) 47.84s. **POINTS 1= Menzies & S Moran, 17: 3 R Moran, 14; 4= Summers & Adams, 10; 6 Willis, 9; Class winners** Samantha Lester (1.6 Citroen

Saxo VTR) 60.15s; Robert Lancaster-Gaye (3.6 Porsche 996 GT3) 56.30s; Darren Luke (1.6 Caterham Suzuki) 52.50s; Simon Jenks (2.3 Caterham CSR) 64.30s; Andrew Russell (1.1 Ginetta G15) 60.18s; David Paterson (1.6 Peugeot 106 Rallye) 52.82s; Mike Turpin (2.2 Vauxhall VX220) 55.39s; Andy Dunbar (2.0 Westfield Vauxhall) 51.17s; Peter Kukainis (2.3 Westfield Duratec) 54.18s; Wynn 49.97s; Manning 49.19s; Summers 47.64s; Adams 46.68s; Simon Moyses (Gould GR59 Suzuki) 50.54s; Menzies 45.54s.



Henderson (left) pips Jenkins by 0.040s

MAZDA MX5 Mk1s SNETTERTON, APRIL 28-29

Roche on top amid tough MX5 fighting

THE BUOYANT MAZDA MX5s journeyed to Norfolk for the second round of their 2012 season. The almost-unremitting rain made the track treacherous, but it couldn't stop reigning champion Tom Roche.

Roche took control of the Groups A and E race from the start, overcoming a safety car that wiped out his early lead. Meanwhile, 2011 runner-up Adam Gore held off Brett Smith for second.

Roche ensured he ended the weekend atop the points table by winning convincingly again in his

other outing. He dominated the A and B race ahead of Ben Short, who survived a late challenge from Gore.

Short went one better to win the B and C race. After an inspired opening lap moved him into the lead, Silverstone victor James Blake-Baldwin suffered a mid-race slip at Agostini, allowing Short to shoot by.

A quartet of Rhys Jenkins, Alan Henderson, Smith and Eduardo Rodrigues headed a pulsating D and E encounter. Jenkins hit the front on lap four, only to lose it in the final moments as early

leader Henderson timed his retaliation perfectly to steal past at the final corner.

Jenkins got his timing just right in the C and D race, dropping back from the lead in order to line up a brilliant last-corner move on Blake-Baldwin to win. ● Oliver Timson

RESULTS - GROUP A & E (7 LAPS)

1 Tom Roche; 2 Adam Gore +3.653s; 3 Brett Smith; 4 Matt Robinson; 5 Simon Baldwin; 6 Daniel Rogers. **Fastest lap** Roche 2m36.934s (68.10mph).

GROUP A & B (7 LAPS)

1 Roche; 2 Ben Short +3.401s; 3 Gore; 4 Charlie Charman; 5 Ed Gay; 6 Robinson. **FL** Gore 2m29.657s (71.41mph).

GROUP B & C (8 LAPS) 1 Short;

2 Alexander Preston +3.841s; 3 Brian Chandler; 4 Simon Goddard; 5 Charman; 6 Gay. **FL** Preston 2m39.019s (67.21mph).

GROUP D & E (8 LAPS) 1 Alan Henderson;

2 Rhys Jenkins +0.040s; 3 Smith; 4 Eduardo Rodrigues; 5 Matthew Lambert; 6 Martin Tolley. **FL** Rodrigues 2m37.223s (67.98mph).

GROUP C & D (7 LAPS) 1 Jenkins;

2 James Blake-Baldwin +0.329s; 3 Henderson; 4 Preston; 5 Scott Leach; 6 Tolley. **FL** Blake-Baldwin 2m37.189s (67.99mph).

MAZDA MX5 Mk3s SNETTERTON, APRIL 28-29

Mazda wins shared

THE MX5 CUP SERVED up a captivating trio of races at Snetterton.

In the first, ex-Formula Ford hotshoe Chrissy Palmer grabbed the lead at the halfway point from 17-year-old karting graduate Jordan Stilp as they tussled side by side through Coram, only for the young gun to shoot around the outside of Palmer at Riches and claim an inspired victory.

Stilp tumbled from pole to the back after a first-lap mishap in race two, allowing Palmer to secure his third win this year. He shrugged off

Eynon Price and Luke Herbert in his mirrors.

Herbert survived pressure from Palmer and Stilp in the finale to make it three different winners. ● Oliver Timson

RESULTS (6 LAPS) 1 Jordan Stilp;

2 Chrissy Palmer +1.293s; 3 Eynon Price; 4 Adam Gore; 5 Paul Sheard; 6 Luke Herbert. **FL** Stilp 2m37.863s (67.70mph).

RACE 2 (5 LAPS) 1 Palmer;

2 Herbert +1.056s; 3 Price; 4 Gore; 5 Sheard; 6 Andrew Clarkson. **FL** Sheard 2m46.323s (64.26mph).

RACE 3 (5 LAPS) 1 Herbert;

2 Palmer +0.136s; 3 Stilp; 4 Sheard; 5 Matthew Davies; 6 Clarkson. **FL** Palmer 2m20.539s (76.05mph).



Palmer and Herbert took a win apiece



Pollock's Van Diemen took first SuperSeries FF1600 win

FF1600 SUPERSERIES KIRKISTOWN, APRIL 28

Pollock takes his chance as FF1600 rivals clash



McCullough and McMullan fought hard, but both lost

OVERSEAS ENTRIES were in distinctly short supply, but the Kirkistown round of James Beckett's new FF1600 SuperSeries was definitely 'super'.

Front-row men Jonny McMullan (Mondiale) and Ivor McCullough (Van Diemen RFoo) were both inside McMullan's lap record during qualifying,

so the race promised plenty. And delivered.

At the outset they were joined by Noel Robinson (RFoo) and Neville Smyth (Ray 09), but when Robinson departed in a cloud of oil smoke and Smyth suffered a quick spin it was left to the front-row pair to provide the excitement.

This they did, swapping places all round the circuit and getting up close and (very) personal on occasion.

It couldn't last, and it all came to a steamy end at Colonial on the final lap when contact removed both from contention. That allowed a surprised Adrian Pollock (Van Diemen DPo8) to take the

win, ahead of Noel Dunne and a recovering Smyth.

McMullan eventually struggled over the line in eighth, with much of his car missing, but had the consolation of lowering his own lap record during the hectic fight.

● Richard Young

RESULTS (16 LAPS) 1 Adrian

Pollock (Van Diemen DPo8): +13.327s; 2 Noel Dunne (Van Diemen RFoo) +13.327s; 3 Neville Smyth (Ray GRO9); 4 Derek M Daly (RF93); 5 David McCullough (RFOO); 6 Ryan Campbell (Reynard FF84). **CW** Campbell; Neville Anderson (Mondiale M89S); Arnie Black (Crossle 32F). **FL** Jonny McMullan (Mondiale M89S) 1m00.905s (89.37mph) **record**.

QUALIFYING RACE (8 LAPS)

1 Pollock; 2 Dunne +1.462s; 3 Daly; 4 McCullough; 5 Anderson; 6 David Nicholl (Reynard FF89). **FL** Pollock 1m01.563s (88.41mph).

IN BRIEF

BRSCC PORSCHE

Richard Sykes dominated all three races at Snetterton. Richard Styrin took a lonely second in race one but had to settle for third behind a charging Gerry Taylor in race two. He responded by claiming second in the finale.

OSS

Darcy Smith inherited victory in a sodden opener at Snetterton after a startline shunt eliminated Tony Sinclair's and Andrew Kimpton's Jades, and Tim Covill and Jonty Hair crashed out dicing for the lead. In a depleted sequel, Smith's spin handed Ginger Marshall the win.

BRSCC CLASS C FIESTAS

Jason Cooper shrugged off a slow start, an early spin and a weight penalty to beat John Langridge and win race one at Snetterton. He then overhauled leader Andrew Foley to win race two.

IRISH FORMULA LIBRE

A slow start followed by a couple of spins kept Philip Shields's GP2 Dallara from showing its true potential in the first Libre race at Kirkistown, and allowed Eamon Matheson's E5 to take the win. Shields got it right in the second race to romp away to a 51s win.

IRISH SALOONS

Newcomer Gerard McVeigh made use of four-wheel drive and turbo power to blast his Mitsubishi Evo 8 off the line first in the saloon bash at Kirkistown. He was never headed. The concurrent GT race went to Pat McBennett's Lotus.

IRISH FIESTAS

James Turkington, brother of ex-BTCC champ Colin, repeated his victory from the March meeting, but had to work hard for it this time at Kirkistown with Chris Rogan chasing all the way.

CLUBMANS CUP

Paul Gibson's Nemesis took a comfortable win at Croft after son and early leader Dan's example went onto three cylinders. The second race was red-flagged and abandoned due to rain.

KUMHO BMW

With reigning champion Garrie Whittaker absent, Colin Wells secured a double at Croft. Karl Skitt started race one strongly, but his challenge ended in the pits.

NORTH WEST SPORTS SALOONS CROFT, APRIL 28-29

Watson holds on before Keenan takes his turn

GARRY WATSON MADE the trip from Scotland to dominate the first race in his Westfield SE.

With Simon Allaway's Esprit V8 breaking a CV joint on lap one, it was left to Danny Keenan (MK Indy) and Robert Spencer's Locosaki to dispute second.

They swapped places on the first lap before Keenan went clear and came within a whisker of snatching a late win, as Watson limped home with a failing clutch.

Keenan was a lights-to-flag winner in a wet race two, with Spencer clinching second after ousting son Joe mid-race. Peter Davies's Caterham was fourth, with Dennis Crompton (BMW

M3) fifth after a fine duel with the Vauxhall Vectra of Mike Hurst.

● Peter Scherer

RESULTS (15 LAPS) 1 Garry Watson

(Westfield SE): 2 Danny Keenan (MK Indy RR) +0.668s; 3 Robert Spencer (Stuart Taylor Locosaki); 4 Joe Spencer (Stuart Taylor Locosaki); 5 Peter Davies (Caterham CSR); 6 Dennis Crompton (BMW E36 M3). **CW** Keenan; Crompton; Richard Hall (Ginetta G20); Martin Addison (Peugeot 106 Rallye). **FL** Watson 1m26.291s (88.65mph).

RACE 2 (13 LAPS) 1 Keenan;

2 R Spencer +1.748s; 3 J Spencer; 4 Davies; 5 Crompton; 6 Oliver Thomas (Subaru Impreza WRX). **CW** Davies; Crompton; Graham Saul (Ford Fiesta XR2). **FL** R Spencer 1m43.287s (74.06mph).



Halliwell took a first and a second at Croft

MAX5 MX5 Mk1s AND Mk3s CROFT, APRIL 28-29

Drama in Croft contest

JONATHAN HALLIWELL was a clear winner in the first MaX5 race after Paul Roddison retired on the fourth lap. But race two proved dramatic, despite only 13 starters.

Jonathan Cryer, who had finished second in race one, built a good lead in the very wet event, only to spin it away at Tower at half-distance.

Halliwell assumed the lead but Roddison hunted him down, having started from the back of the grid in a spare car.

Roddison made the decisive move into the Complex, while Cryer recovered to complete the podium.

● Peter Scherer

RESULTS (12 LAPS)

1 Jonathan Halliwell; 2 Jonathan Cryer +13.884s; 3 Jeremy Shipley; 4 Clive Bussey; 5 Jeremy Hibbert; 6 Ian Loveridge. **CW** Phil Grayston. **FL** Halliwell 1m40.863s (75.84mph). **RACE 2 (10 LAPS) 1 Paul Roddison;** 2 Halliwell +6.056s; 3 Cryer; 4 Grayston; 5 Hibbert; 6 Bussey. **CW** Grayston. **FL** Roddison 2m03.991s (61.69mph).

Watson won race one despite clutch issues





vodafone DMAX ENTRIES UP BY OVER 100% FOR 2012

**BIGGER THAN EVER, NEW WEIGHT CLASSES, NEW CIRCUITS
EVEN BETTER VALUE - LESS THAN £1500 FOR A SEASONS RACING**

DMAX

Come along and see why Vodafone Dmax is the UK's leading karting championship



Rnd	Date	Venue	Circuit
3	15th April	Daytona Sandown Park	Grand Prix
4	20th May	Lydd, Kent	Clubman
5	17th June	Whilton Mill, Northants	National Circuit
6	8th July	Daytona Milton Keynes	International Extra
7	19th August	PF International, Lincs	Extended Circuit
8	16th September	Daytona Milton Keynes	International
9	21st October	Rye House, Herts	Raceway Circuit
10	18th November	Daytona Sandown Park	Alternate

Tel: 0845 644 5504
www.daytonamax.co.uk



WANT IRONMONGERY DELIVERED NEXT DAY? CALL THE MASTERS.

UK'S
BIGGEST RANGE
NEXT DAY DELIVERY
AWARD WINNING
SERVICE
MONEY BACK
GUARANTEE



CALL NOW FOR YOUR
FREE CATALOGUE

0808 168 28 28
IronmongeryDirect.com

Or TEXT **RBA16** to 62244 FREE! (With name, address and email).

IronmongeryDirect

MASTERS OF OUR TRADE

DOOR FURNITURE • WINDOW & JOINERY HARDWARE • SLIDING DOOR HARDWARE • HINGES • DOOR CLOSERS • FIRE CONTROL • SIGNS
LOCKS, LATCHES & SECURITY • CABINET FURNITURE • SHELVING & STORAGE • BOLTS & STOPS • SEALANTS & ADHESIVES • SCREWS & FIXINGS

SPORTS EXTRA RESULTS ROUND-UP

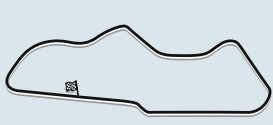

Donington Park National



Silverstone National



Snetterton 300



Kirkistown



Croft

Jamie Martin and Kevin Glover battled for Mk2 Golf honours



DONINGTON PARK MSVR, APRIL 28-29

MONOPOSTO 2000/CLASSIC

(11 LAPS) 1 Malcolm Scott (Dallara F398); 2 Peter Venn (F398)+4730s; 3 Richard Purcell (F301); 4 Steve Patania (F301); 5 Tony Bishop (F398); 6 Anton Spires (Tatuus Formula Renault). **Class winner** Jim Blockley (Ralt RT3). **Fastest lap** Scott 1m09.134s (103.05mph).

RACE 2 (10 LAPS) 1 Robbie Watts (Lola F106/03); 2 Spire +19.217s; 3 Blockley; 4 Scott; 5 Russ Giles (F398); 6 Bishop. **CW** Blockley. **FL** Watts 1m28.070s (80.89mph).

RADICAL CLUBMANS CUP (18 LAPS) 1 Matt Bell (SR3 RS); 2 Steve Burgess (SR3 RS)+7477s; 3 Phil Abbott (SR3 RS); 4 Timothy Lyons (SR3 RS); 5 Bradley Smith (SR3 RS); 6 Andy Cummings (SR3 RS). **CW** Brian Murphy (PR6). **FL** P Abbott 1m07.876s (104.96mph).

RACE 2 (16 LAPS) 1 Bell; 2 Smith +0.307s; 3 P Abbott; 4 Mark Abbott (PR6); 5 Lyons; 6 Paul Marsham (SR3 RS). **CW** M Abbott. **FL** Smith 1m07.753s (105.15mph).

MONO 1800/1600/MOTOMONO (10 LAPS) 1 Marc Fortune (Jedi Mk6); 2 Adrian Wright (GEM AW3)+31.675s; 3 Geoff Fern (JKS TFR11); 4 Paul Britten (Van Diemen RFO0); 5 Craig Hurren (Jedi Mk4); 6 Oly Thorpe (Royale). **CW** Britten; Nigel Davers (Van Diemen RF89). **FL** Fortune 1m09.249s (102.88mph).

RACE 2 (8 LAPS) 1 Wright; 2 Davers +0.153s; 3 Dan Levy (Jedi Mk IV); 4 Fortune; 5 Jason Timms (Speads RM07); 6 Britten. **CW** Davers; Britten. **FL** Wright 1m35.217s (74.82mph).

Richard Sykes won all three BRSCC Porsche races at Snett



CLUB MSV TEAM TROPHY (43 LAPS)

1 Stephen Darbey/Alistair Stenhouse (BMW E36); 2 Anthony Campbell (Porsche 968 CS)+34.500s; 3 George Wright (Porsche 993 CS); 4 Gary Campbell (968 CS); 5 Mike Moss (BMW M3); 6 Chris Hoey/Adam Stevenson (Renault Clio).

CW Wright; Andrew Ball/Adrian Walker (968); Ashley Bird/Edward Platt (Ginetta G20). **FL** Stenhouse 1m20.048s (89.00mph). **RACE 2 (34 LAPS)** 1 James Britton (M3); 2 Will Jackson-Moore (Clio) +54.97s; 3 Ricky Coomber/Joe Giovannini (BMW Cooper S); 4 Darbey/Stenhouse; 5 Wright; 6 Marcus Burnett/William Burnett (M3). **CW** Steven Brown/Adam McKeever/Matthew Weymouth (BMW 328i); Steve Brenton/Tom Brenton (Austin A35). **FL** Jackson-Moore 1m40.522s (70.87mph).

GOLF MK2 GTI (11 LAPS) 1 Jamie Martin; 2 Darren Bedford +14.982s; 3 Kevin Glover; 4 Simon Gusterson; 5 James Colbourne; 6 Martyn Walsh. **CW** Alex Harris. **FL** Glover 1m25.882s (82.95mph).

RACE 2 (9 LAPS) 1 Martin; 2 Glover +7.471s; 3 Walsh; 4 Mark Reynolds; 5 Andrew Aldridge; 6 Darren Drury. **CW** Tim Cox. **FL** Aldridge 1m41.661s (70.08mph).

FERRARI CLASSIC (15 LAPS) 1 David Tomlin (308GTB); 2 Jim Cartwright (328GTB)+14.077s; 3 Wayne Marrs (328GTB); 4 Tristan Simpson (308GT4); 5 Tim Walker (328GTB); 6 Jack Dwane

(Mondial QV). **CW** Cartwright; Simpson; Walker. **FL** Tomlin 1m20.903s (72.99mph).

'50s SPORTS CARS (22 LAPS) 1 John Burton (Jaguar XK120); 2 Mike Thorne (Austin Healey 100M)+12.36s; 3 Robert Rawe (Aston Martin DB4); 4 Mark Hoble (Morgan Plus 4); 5 Chris Keith-Lucas (Jaguar XK120); 6 Kevin Zwolinski (Jaguar XK140 FHC). **CW** Thorne; Rawe; Martin Melling (Aston Martin DB3); Anne Reed (Aston Martin DB2); Neil Perkins (RGS Atlanta Sports); Peter Dubsky (Aston Martin 1598). **FL** Burton 1m20.812s (73.07mph).

EQUIPE GTS (24 LAPS) 1 Richard Plant (Morgan Plus 4); 2 Pete Foster (Triumph TR4)+3.938s; 3 John Andon (Triumph TR4); 4 Ronald Watt (MGB); 5 Robert Rawe (Austin Healey 100M); 6 Mark Hoble (Morgan Plus 4). **CW** Watt; Keith Hampson (Sunbeam Alpine Le Mans); David Beatty (Triumph Spitfire). **FL** Plant 1m13.034s (80.85mph).

**SILVERSTONE
AMOC, APRIL 28**

FERRARI CLASSIC (15 LAPS) 1 David Tomlin (308GTB); 2 Jim Cartwright (328GTB)+14.077s; 3 Wayne Marrs (328GTB); 4 Tristan Simpson (308GT4); 5 Tim Walker (328GTB); 6 Jack Dwane

(Mondial QV). **CW** Cartwright; Simpson; Walker. **FL** Tomlin 1m20.903s (72.99mph).

'50s SPORTS CARS (22 LAPS) 1 John Burton (Jaguar XK120); 2 Mike Thorne (Austin Healey 100M)+12.36s; 3 Robert Rawe (Aston Martin DB4); 4 Mark Hoble (Morgan Plus 4); 5 Chris Keith-Lucas (Jaguar XK120); 6 Kevin Zwolinski (Jaguar XK140 FHC). **CW** Thorne; Rawe; Martin Melling (Aston Martin DB3); Anne Reed (Aston Martin DB2); Neil Perkins (RGS Atlanta Sports); Peter Dubsky (Aston Martin 1598). **FL** Burton 1m20.812s (73.07mph).

EQUIPE GTS (24 LAPS) 1 Richard Plant (Morgan Plus 4); 2 Pete Foster (Triumph TR4)+3.938s; 3 John Andon (Triumph TR4); 4 Ronald Watt (MGB); 5 Robert Rawe (Austin Healey 100M); 6 Mark Hoble (Morgan Plus 4). **CW** Watt; Keith Hampson (Sunbeam Alpine Le Mans); David Beatty (Triumph Spitfire). **FL** Plant 1m13.034s (80.85mph).

**SNETTERTON
BRSCC, APRIL 28-29**

BRSCC PORSCHEs (9 LAPS) 1 Richard Sykes (Boxster); 2 Richard Styron (Boxster)+19.085s; 3 David Bearman (Boxster); 4 Gerry Taylor (Boxster); 5 Tom Andrew (Boxster); 6 John Bearman (Boxster). **CW** Steven Brown (Boxster); Rebecca Jackson (924). **FL** Sykes 2m27.134s (72.64mph).

RACE 2 (7 LAPS) 1 Sykes; 2 Taylor +3.562s; 3 Styron; 4 Andrew; 5 D Bearman; 6 J Bearman. **CW** Brown; James Atherton (924). **FL** Sykes 2m31.474s (70.56mph).

RACE 3 (7 LAPS) 1 Sykes; 2 Styron +10.281s; 3 Taylor; 4 D Bearman; 5 Andrew; 6 J Bearman. **CW** Brown; Alistair Kirkham (924). **FL** Sykes 2m26.954s (72.73mph).

OPEN SPORTSCARS (7 LAPS) 1 Darcy Smith (Radical SR4); 2 Ginger Marshall (Bowly Mark 2)+43.821s; 3 Ake Bornebusch (Radical Pro 6); 4 Robert Ball (Nemesis RME7); 5 Peter Coombs (Coombs Sports 6C); 6 Gary Ramsdale (Radical SR3 RS). **CW** Bornebusch; Coombs. **FL** Jonathan Hair (Mallock Beagle Mk3 6DD) 2m17.066s (77.97mph).

RACE 2 (8 LAPS) 1 Marshall; 2 Smith +10.606s; 3 Bornebusch; 4 Ball; 5 Coombs; 6 John Wilkes (Global GT R1).

BRSCC FIESTA CLASS C (8 LAPS) 1 Jason Cooper; 2 John Langridge +4.469s; 3 Andrew Foley; 4 Shaun Clay; 5 Aaron Trigwell; 6 Nicholas Bowers. **FL** Cooper 2m30.241s (71.13mph).

RACE 2 (7 LAPS) 1 Cooper; 2 Foley +1.719s; 3 Clay; 4 Andrew Wilmot; 5 Trigwell; 6 Bowers. **FL** Cooper 2m27.744s (72.34mph).

MASDA MX150R (BOTH 6 LAPS) 1 Brett Smith (MX5); 2 Rhys Jenkins (MX5) +0.166s; 3 Matt Robinson (MX5); 4 Simon Goddard (MX5); 5 Mark Litherland (MX5); 6 Martin Tolley (MX5). **FL** Smith 2m38.688s (67.35mph). **RACE 2** 1 Jenkins; 2 Smith +2.079s; 3 Robinson; 4 Tolley; 5 Goddard; 6 Carl Powell. **FL** Jenkins 2m36.949s (68.09mph).

BRSCC FIESTA JUNIORS (6 LAPS) 1 Charles Ladell; 2 Freddie Lee +18.359s; 3 Jack Mitchell; 4 Louis Millar; 5 Ben Wilcox; 6 Bobby Thompson. **FL** Ladell 2m29.267s (71.60mph). **RACE 2 (5 LAPS)** 1 Ladell; 2 Mitchell +2.964s; 3 Lee; 4 Wilcox; 5 Thompson; 6 Aiden Moffat. **FL** Mitchell 2m30.450s (71.04mph).

BRSCC FIESTA CLASSES A & B (8 LAPS) 1 Torsten Skeen (Si); 2 David Elsom (Si)+22.984s; 3 Nikolas Barton (Zetec); 4 Chris Toumazos (Si); 5 Ian Scruton (Si); 6 Terry Scruton (Si). **CW** Barton. **FL** Skeen 2m37.897s (67.69mph). **RACE 2 (7 LAPS)** 1 Skeen; 2 Elsom +17.450s; 3 T Scruton; 4 I Scruton; 5 Barton; 6 Michel Edwards (Zetec). **CW** Barton. **FL** Skeen 2m32.420s (70.12mph).

**KIRKISTOWN
500MRCI, APRIL 28-29**

FORMULA LIBRE (12 LAPS) 1 Eamon Matheson (1.3t E5); 2 Mark Crawford (1.0 Jedi Suzuki)+4.098s; 3 Martin Daly (2.0 Tatuus Renault); 4 John Daly (3.8 Lola Holden); 5 Peter Dwyer (2.0 Dallara Renault 399); 6 Michael Roche (2.0 Dallara GM 391). **FL** Matheson 57.228s (95.11mph).

RACE 2 (15 LAPS) 1 Philip Shields (4.0 Dallara Renault GP2); 2 Crawford +51.125s; 3 Dwyer; 4 M Daly; 5 Paul Heavey (1.0 Leaston Suzuki); 6 Stanley Watson (2.0 Van Diemen F1r1). **FL** Shields 52.989s (102.72mph).

IRISH SALOONS (13 LAPS) 1 Gerard McVeigh (2.0t Mitsubishi Evo 8); 2 Ralph Jess (3.2 BMW M3)+11.805s; 3 Greer Wray (3.2 Vauxhall Vectra); 4 Donal O'Neill (1.8t SEAT Cupra); 5 Robert Patton (2.0 Honda Integra); 6 Andrew Armstrong (1.6 Honda Civic). **CW** Armstrong. **FL** Wray 1m04.099s (84.92mph).

GT CARS (13 LAPS) 1 Pat McC Bennett (2.0 Lotus Elise); 2 Tommy Holmes (2.0 Honda S2000) -1 lap, no other finishers. **FL** McC Bennett 1m01.988s (87.81mph).

CW Bornebusch; Coombs. **FL** Smith 2m27.339s (72.54mph).

BRSCC FIESTA CLASS C (8 LAPS) 1 Jason Cooper; 2 John Langridge +4.469s; 3 Andrew Foley; 4 Shaun Clay; 5 Aaron Trigwell; 6 Nicholas Bowers. **FL** Cooper 2m30.241s (71.13mph).

RACE 2 (7 LAPS) 1 Cooper; 2 Foley +1.719s; 3 Clay; 4 Andrew Wilmot; 5 Trigwell; 6 Bowers. **FL** Cooper 2m27.744s (72.34mph).

MASDA MX150R (BOTH 6 LAPS) 1 Brett Smith (MX5); 2 Rhys Jenkins (MX5) +0.166s; 3 Matt Robinson (MX5); 4 Simon Goddard (MX5); 5 Mark Litherland (MX5); 6 Martin Tolley (MX5). **FL** Smith 2m38.688s (67.35mph). **RACE 2** 1 Jenkins; 2 Smith +2.079s; 3 Robinson; 4 Tolley; 5 Goddard; 6 Carl Powell. **FL** Jenkins 2m36.949s (68.09mph).

BRSCC FIESTA JUNIORS (6 LAPS) 1 Charles Ladell; 2 Freddie Lee +18.359s; 3 Jack Mitchell; 4 Louis Millar; 5 Ben Wilcox; 6 Bobby Thompson. **FL** Ladell 2m29.267s (71.60mph). **RACE 2 (5 LAPS)** 1 Ladell; 2 Mitchell +2.964s; 3 Lee; 4 Wilcox; 5 Thompson; 6 Aiden Moffat. **FL** Mitchell 2m30.450s (71.04mph).

BRSCC FIESTA CLASSES A & B (8 LAPS) 1 Torsten Skeen (Si); 2 David Elsom (Si)+22.984s; 3 Nikolas Barton (Zetec); 4 Chris Toumazos (Si); 5 Ian Scruton (Si); 6 Terry Scruton (Si). **CW** Barton. **FL** Skeen 2m37.897s (67.69mph). **RACE 2 (7 LAPS)** 1 Skeen; 2 Elsom +17.450s; 3 T Scruton; 4 I Scruton; 5 Barton; 6 Michel Edwards (Zetec). **CW** Barton. **FL** Skeen 2m32.420s (70.12mph).

**KIRKISTOWN
500MRCI, APRIL 28-29**

FORMULA LIBRE (12 LAPS) 1 Eamon Matheson (1.3t E5); 2 Mark Crawford (1.0 Jedi Suzuki)+4.098s; 3 Martin Daly (2.0 Tatuus Renault); 4 John Daly (3.8 Lola Holden); 5 Peter Dwyer (2.0 Dallara Renault 399); 6 Michael Roche (2.0 Dallara GM 391). **FL** Matheson 57.228s (95.11mph).

RACE 2 (15 LAPS) 1 Philip Shields (4.0 Dallara Renault GP2); 2 Crawford +51.125s; 3 Dwyer; 4 M Daly; 5 Paul Heavey (1.0 Leaston Suzuki); 6 Stanley Watson (2.0 Van Diemen F1r1). **FL** Shields 52.989s (102.72mph).

IRISH SALOONS (13 LAPS) 1 Gerard McVeigh (2.0t Mitsubishi Evo 8); 2 Ralph Jess (3.2 BMW M3)+11.805s; 3 Greer Wray (3.2 Vauxhall Vectra); 4 Donal O'Neill (1.8t SEAT Cupra); 5 Robert Patton (2.0 Honda Integra); 6 Andrew Armstrong (1.6 Honda Civic). **CW** Armstrong. **FL** Wray 1m04.099s (84.92mph).

GT CARS (13 LAPS) 1 Pat McC Bennett (2.0 Lotus Elise); 2 Tommy Holmes (2.0 Honda S2000) -1 lap, no other finishers. **FL** McC Bennett 1m01.988s (87.81mph).

IRISH FIESTAS (10 LAPS) 1 James Turkington; 2 Chris Rogan +0.368s; 3 Andrew McShane; 4 Ian Newport; 5 Roy Smyth; 6 Ryan Robinson. **FL** McShane 1m18.135s (69.66mph). **record** GINETTA JUNIOR IRELAND (BOTH 10 LAPS) 1 Jake Byrne; 2 James Fleming +21.45s; 3 Andrew Clarke; 4 Jack Finlay; 5 Sophie Byrne; 6 Luke Hourihan.

FL Clarke 1m11.972s (75.63mph). **RACE 2** 1 J Byrne; 2 Clarke +3.857s; 3 Fleming; 4 Dylan Curley; 5 S Byrne; 6 Finlay. **FL** Fleming 1m11.861s (75.74mph).

ROADSPORTS (BOTH 13 LAPS) 1 Aarn Black (2.0 Crossle Ford 9S); 2 Ryan Magennis (1.0 GMS Honda) +12.470s; 3 Alan Davidson (1.0 GMS Honda); 4 Jack Boal (1.0 Locost Honda); 5 Graham Moore (1.0 Westfield Honda); 6 Johnny Armstrong (1.0 Westfield Honda). **CW** Magennis. **FL** Black 1m01.487s (88.52mph). **RACE 2** 1 Black; 2 Magennis +7.151s; 3 Davidson; 4 Trevor Allen (1.0 Stryker Honda); 5 Jimmy Dougan (1.0 Locost Honda); 6 Laurence Mawhinney (1.0 Westfield Honda). **CW** Magennis. **FL** Black 1m02.106s (87.64mph).

ROADSPORTS (BOTH 13 LAPS) 1 Aarn Black (2.0 Crossle Ford 9S); 2 Ryan Magennis (1.0 GMS Honda) +12.470s; 3 Alan Davidson (1.0 GMS Honda); 4 Jack Boal (1.0 Locost Honda); 5 Graham Moore (1.0 Westfield Honda); 6 Johnny Armstrong (1.0 Westfield Honda). **CW** Magennis. **FL** Black 1m01.487s (88.52mph). **RACE 2** 1 Black; 2 Magennis +7.151s; 3 Davidson; 4 Trevor Allen (1.0 Stryker Honda); 5 Jimmy Dougan (1.0 Locost Honda); 6 Laurence Mawhinney (1.0 Westfield Honda). **CW** Magennis. **FL** Black 1m02.106s (87.64mph).

ROADSPORTS (BOTH 13 LAPS) 1 Aarn Black (2.0 Crossle Ford 9S); 2 Ryan Magennis (1.0 GMS Honda) +12.470s; 3 Alan Davidson (1.0 GMS Honda); 4 Jack Boal (1.0 Locost Honda); 5 Graham Moore (1.0 Westfield Honda); 6 Johnny Armstrong (1.0 Westfield Honda). **CW** Magennis. **FL** Black 1m01.487s (88.52mph). **RACE 2** 1 Black; 2 Magennis +7.151s; 3 Davidson; 4 Trevor Allen (1.0 Stryker Honda); 5 Jimmy Dougan (1.0 Locost Honda); 6 Laurence Mawhinney (1.0 Westfield Honda). **CW** Magennis. **FL** Black 1m02.106s (87.64mph).

ROADSPORTS (BOTH 13 LAPS) 1 Aarn Black (2.0 Crossle Ford 9S); 2 Ryan Magennis (1.0 GMS Honda) +12.470s; 3 Alan Davidson (1.0 GMS Honda); 4 Jack Boal (1.0 Locost Honda); 5 Graham Moore (1.0 Westfield Honda); 6 Johnny Armstrong (1.0 Westfield Honda). **CW** Magennis. **FL** Black 1m01.487s (88.52mph). **RACE 2** 1 Black; 2 Magennis +7.151s; 3 Davidson; 4 Trevor Allen (1.0 Stryker Honda); 5 Jimmy Dougan (1.0 Locost Honda); 6 Laurence Mawhinney (1.0 Westfield Honda). **CW** Magennis. **FL** Black 1m02.106s (87.64mph).

ROADSPORTS (BOTH 13 LAPS) 1 Aarn Black (2.0 Crossle Ford 9S); 2 Ryan Magennis (1.0 GMS Honda) +12.470s; 3 Alan Davidson (1.0 GMS Honda); 4 Jack Boal (1.0 Locost Honda); 5 Graham Moore (1.0 Westfield Honda); 6 Johnny Armstrong (1.0 Westfield Honda). **CW** Magennis. **FL** Black 1m01.487s (88.52mph). **RACE 2** 1 Black; 2 Magennis +7.151s; 3 Davidson; 4 Trevor Allen (1.0 Stryker Honda); 5 Jimmy Dougan (1.0 Locost Honda); 6 Laurence Mawhinney (1.0 Westfield Honda). **CW** Magennis. **FL** Black 1m02.106s (87.64mph).

ROADSPORTS (BOTH 13 LAPS) 1 Aarn Black (2.0 Crossle Ford 9S); 2 Ryan Magennis (1.0 GMS Honda) +12.470s; 3 Alan Davidson (1.0 GMS Honda); 4 Jack Boal (1.0 Locost Honda); 5 Graham Moore (1.0 Westfield Honda); 6 Johnny Armstrong (1.0 Westfield Honda). **CW** Magennis. **FL** Black 1m01.487s (88.52mph). **RACE 2** 1 Black; 2 Magennis +7.151s; 3 Davidson; 4 Trevor Allen (1.0 Stryker Honda); 5 Jimmy Dougan (1.0 Locost Honda); 6 Laurence Mawhinney (1.0 Westfield Honda). **CW** Magennis. **FL** Black 1m02.106s (87.64mph).

ROADSPORTS (BOTH 13 LAPS) 1 Aarn Black (2.0 Crossle Ford 9S); 2 Ryan Magennis (1.0 GMS Honda) +12.470s; 3 Alan Davidson (1.0 GMS Honda); 4 Jack Boal (1.0 Locost Honda); 5 Graham Moore (1.0 Westfield Honda); 6 Johnny Armstrong (1.0 Westfield Honda). **CW** Magennis. **FL** Black 1m01.487s (88.52mph). **RACE 2** 1 Black; 2 Magennis +7.151s; 3 Davidson; 4 Trevor Allen (1.0 Stryker Honda); 5 Jimmy Dougan (1.0 Locost Honda); 6 Laurence Mawhinney (1.0 Westfield Honda). **CW** Magennis. **FL** Black 1m02.106s (87.64mph).

ROADSPORTS (BOTH 13 LAPS) 1 Aarn Black (2.0 Crossle Ford 9S); 2 Ryan Magennis (1.0 GMS Honda) +12.470s; 3 Alan Davidson (1.0 GMS Honda); 4 Jack Boal (1.0 Locost Honda); 5 Graham Moore (1.0 Westfield Honda); 6 Johnny Armstrong (1.0 Westfield Honda). **CW** Magennis. **FL** Black 1m01.487s (88.52mph). **RACE 2** 1 Black; 2 Magennis +7.151s; 3 Davidson; 4 Trevor Allen (1.0 Stryker Honda); 5 Jimmy Dougan (1.0 Locost Honda); 6 Laurence Mawhinney (1.0 Westfield Honda). **CW** Magennis. **FL** Black 1m02.106s (87.64mph).

ROADSPORTS (BOTH 13 LAPS) 1 Aarn Black (2.0 Crossle Ford 9S); 2 Ryan Magennis (1.0 GMS Honda) +12.470s; 3 Alan Davidson (1.0 GMS Honda); 4 Jack Boal (1.0 Locost Honda); 5 Graham Moore (1.0 Westfield Honda); 6 Johnny Armstrong (1.0 Westfield Honda). **CW** Magennis. **FL** Black 1m01.487s (88.52mph). **RACE 2** 1 Black; 2 Magennis +7.151s; 3 Davidson; 4 Trevor Allen (1.0 Stryker Honda); 5 Jimmy Dougan (1.0 Locost Honda); 6 Laurence Mawhinney (1.0 Westfield Honda). **CW** Magennis. **FL** Black 1m02.106s (87.64mph).

ROADSPORTS (BOTH 13 LAPS) 1 Aarn Black (2.0 Crossle Ford 9S); 2 Ryan Magennis (1.0 GMS Honda) +12.470s; 3 Alan Davidson (1.0 GMS Honda); 4 Jack Boal (1.0 Locost Honda); 5 Graham Moore (1.0 Westfield Honda); 6 Johnny Armstrong (1.0 Westfield Honda). **CW** Magennis. **FL** Black 1m01.487s (88.52mph). **RACE 2** 1 Black; 2 Magennis +7.151s; 3 Davidson; 4 Trevor Allen (1.0 Stryker Honda); 5 Jimmy Dougan (1.0 Locost Honda); 6 Laurence Mawhinney (1.0 Westfield Honda). **CW** Magennis. **FL** Black 1m02.106s (87.64mph).

ROADSPORTS (BOTH 13 LAPS) 1 Aarn Black (2.0 Crossle Ford 9S); 2 Ryan Magennis (1.0 GMS Honda) +12.470s; 3 Alan Davidson (1.0 GMS Honda); 4 Jack Boal (1.0 Locost Honda); 5 Graham Moore (1.0 Westfield Honda); 6 Johnny Armstrong (1.0 Westfield Honda). **CW** Magennis. **FL** Black 1m01.487s (88.52mph). **RACE 2** 1 Black; 2 Magennis +7.151s; 3 Davidson; 4 Trevor Allen (1.0 Stryker Honda); 5 Jimmy Dougan (1.0 Locost Honda); 6 Laurence Mawhinney (1.0 Westfield Honda). **CW** Magennis. **FL** Black 1m02.106s (87.64mph).

ROADSPORTS (BOTH 13 LAPS) 1 Aarn Black (2.0 Crossle Ford 9S); 2 Ryan Magennis (1.0 GMS Honda) +12.470s; 3 Alan Davidson (1.0 GMS Honda); 4 Jack Boal (1.0 Locost Honda); 5 Graham Moore (1.0 Westfield Honda); 6 Johnny Armstrong (1.0 Westfield Honda). **CW** Magennis. **FL** Black 1m01.487s (88.52mph). **RACE 2** 1 Black; 2 Magennis +7.151s; 3 Davidson; 4 Trevor Allen (1.0 Stryker Honda); 5 Jimmy Dougan (1.0 Locost Honda); 6 Laurence Mawhinney (1.0 Westfield Honda). **CW** Magennis. **FL** Black 1m02.106s (87.64mph).

ROADSPORTS (BOTH 13 LAPS) 1 Aarn Black (2.0 Crossle Ford 9S); 2 Ryan Magennis (1.0 GMS Honda) +12.470s; 3 Alan Davidson (1.0 GMS Honda); 4 Jack Boal (1.0 Locost Honda); 5 Graham Moore (1.0 Westfield Honda); 6 Johnny Armstrong (1.0 Westfield Honda). **CW** Magennis. **FL** Black 1m01.487s (88.52mph). **RACE 2** 1 Black; 2 Magennis +7.151s; 3 Davidson; 4 Trevor Allen (1.0 Stryker Honda); 5 Jimmy Dougan (1.0 Locost Honda); 6 Laurence Mawhinney (1.0 Westfield Honda). **CW** Magennis. **FL** Black 1m02.106s (87.64mph).

ROADSPORTS (BOTH 13 LAPS) 1 Aarn Black (2.0 Crossle Ford 9S); 2 Ryan Magennis (1.0 GMS Honda) +12.470s; 3 Alan Davidson (1.0 GMS Honda); 4 Jack Boal (1.0 Locost Honda); 5 Graham Moore (1.0 Westfield Honda); 6 Johnny Armstrong (1.0 Westfield Honda). **CW** Magennis. **FL** Black 1m01.487s (88.52mph). **RACE 2** 1 Black; 2 Magennis +7.151s; 3 Davidson; 4 Trevor Allen (1.0 Stryker Honda); 5 Jimmy Dougan (1.0 Locost Honda); 6 Laurence Mawhinney (1.0 Westfield Honda). **CW** Magennis. **FL** Black 1m02.106s (87.64mph).

ROADSPORTS (BOTH 13 LAPS) 1 Aarn Black (2.0 Crossle Ford 9S); 2 Ryan Magennis (1.0 GMS Honda) +12.470s; 3 Alan Davidson (1.0 GMS Honda); 4 Jack Boal (1.0 Locost Honda); 5 Graham Moore (1.0 Westfield Honda); 6 Johnny Armstrong (1.0 Westfield Honda). **CW** Magennis. **FL** Black 1m01.487s (88.52mph). **RACE 2** 1 Black; 2 Magennis +7.151s; 3 Davidson; 4 Trevor Allen (1.0 Stryker Honda); 5 Jimmy Dougan (1.0 Locost Honda); 6 Laurence Mawhinney (1.0 Westfield Honda). **CW** Magennis. **FL** Black 1m02.106s (87.64mph).

ROADSPORTS (BOTH 13 LAPS) 1 Aarn Black (2.0 Crossle Ford 9S); 2 Ryan Magennis (1.0 GMS Honda) +12.470s; 3 Alan Davidson (1.0 GMS Honda); 4 Jack Boal (1.0 Locost Honda); 5 Graham Moore (1.0 Westfield Honda); 6 Johnny Armstrong (1.0 Westfield Honda). **CW** Magennis. **FL** Black 1m01.487s (88.52mph). **RACE 2** 1 Black; 2 Magennis +7.151s; 3 Davidson; 4 Trevor Allen (1.0 Stryker Honda); 5 Jimmy Dougan (1.0 Locost Honda); 6 Laurence Mawhinney (1.0 Westfield Honda). **CW** Magennis. **FL** Black 1m02.106s (87.64mph).

YOUR SAY

What you think of the motorsport news of the past week



You're too modest, Sebastian

Sebastian Vettel said of Red Bull this week: "We're not as confident as we used to be." In my mind this is a classic case of 'mind games' – the sort of nonsense that Manchester United manager Sir Alex Ferguson would be proud of.

I don't believe for one minute that Sebastian Vettel doesn't think he can win this year's championship. It's clearly wide open and there for the taking. To underestimate Red Bull and Vettel would be a huge mistake – just what Sebastian is hoping for I am sure!

Alan White, Clavering, Essex

AUTOSPORT.COM

TOP FIVE ON OUR WEBSITE

1. FIA INSTITUTE TESTING FORWARD ROLL HOOPS
2. ECCLESTONE SAYS FRENCH GP DEAL IS DONE
3. RED BULL DOUBTS DOMINANCE WILL RESUME
4. HRT WILL NOT ATTEND MUGELLO TEST
5. RED BULL TEAMS SET TO TEST IN ABU DHABI

AUTOSPORT.COM PLUS

TOP STORY ONLINE

SCHU'S TYRE GRIPES ARE GOOD FOR F1

To read this exclusive feature and many others like it, log on to autosport.com/plus and choose which package you'd like. A month will cost £5.50, a year £46. Includes access to Forix – the ultimate stats website.

WIN!



ROAD ANGEL VANTAGE

This week's star letter will receive a Road Angel Vantage – a dedicated safety camera and blackspot locator that displays the legal speed limit of every road you drive, automatically and wirelessly updating its database every few minutes as you drive. For more details on Road Angel visit www.roadangelgroup.com Please ensure that your full address is included on all correspondence.

CORRECTIONS AND CLARIFICATIONS

James Hammond did not take pole position for the Formula Ford 1600 Post-89 race at Oulton Park, as reported on p83 of our April 26 issue. That honour fell to Neil Winn, who finished second with fastest lap. Hammond actually qualified eighth.

It is the policy of AUTOSPORT to correct significant errors as soon as possible. Please note the issue date and page number when contacting us on autosport.editorial@haynet.com

EDITORIAL CONTACT mail@autosport.com

Pictures, they say, are

worth a thousand words. Based on two in last week's AUTOSPORT from Bahrain, it seems Red Bull can still run its front wing closer to the ground than its competitors.

The picture on p31 shows the wings of Vettel's and Webber's cars noticeably closer to the ground than the McLaren and Lotus. Check again on p28-29 and Vettel's is still closer to the ground than Raikkonen's much later in the race. Red Bull obviously still has an aero advantage.

David Rusher
Chippenham, Wiltshire

Edd Straw wrote recently

that F1 is a thinking man's sport and always has been. He was of course talking about tyre degradation and how the drivers manage it.

Now Michael Schumacher says everyone has to drive below the limit to maintain the tyres. I'm no Schumi fan, but there's no doubt he knows a thing or two about racing.

The winner should be the fastest driver in the fastest car, not the driver who crosses the line with the tyres in the best condition.

Graeme Lovell
Warwick

Congratulations DTM for

the new generation! It was good, exciting racing action from start to finish.

I do not want to criticise, but now I want the DTM to change its name and have 30 races a year all around Europe so I can enjoy even more.

Patrik Knoos
Saffle, Sweden

Your news story (April

26, p22) failed to ask the obvious question: why is Bentley not entering its V8 coupe in the DTM?

Chris Rouse
Guildtown, Perth

Five of the top 10 Rally

Argentina finishers re-entered under Rally 2 regulations. This rule (in its various guises) is and always has been a nonsense. If you retire, sorry, but you retire.

I know all the justifications, but what about the privateers or semi-privateers who have spent their hard-earned cash and sponsorship money to get there? If I were them I'd feel hacked off to say the least having completed the whole event only to be 'beaten' by someone who hasn't.

Andy Maclean
Churchill, Oxon

THE LATEST GEAR

Desirable new releases for motor racing fans: books, DVDs, models, art and gifts



MERCEDES F1 MERCHANDISE

From £27.99 (autosport.com/shop)

The factory Mercedes F1 team scored its first win since the mid-1950s when Nico Rosberg triumphed in China, so there's a lot of interest in the Brackley-based former Brawn/Honda/BAR squad. And with Michael Schumacher – now in year three of his comeback tour – alongside Nico, the official merchandise is sure to be popular. Here's some of the kit: team/driver caps (£27.99), Schumacher T-shirts (£44.99), team polos (£64.99), team shirts (£84.99) and team jackets (£149.99).

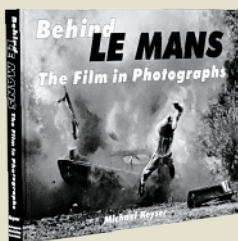

McRAE 1:43 FORD SIERRA

£32.99
(autosport.com/shop)

An unusual diecast that caught our eye: IXO's 1:43-scale Ford Sierra RS Cosworth used by a certain young Colin McRae, and co-driver Derek Ringer, to finish fourth on the 1990 Ypres Rally, Belgium's classic asphalt European Rally Championship round. This one's probably for serious McRae fans only.

LE MANS FILM PHOTOBOOK

£39.99
(autosport.com/shop)

A unique, behind-the-scenes look at the Steve McQueen classic of 1971. Compiled by former racer and sportscar doyen Michael Keyser, this 196-page hardback features numerous images from celebrated snapper Nigel Snowden and will doubtless dispel a few myths from the cult movie.

VETTEL 1:18 MODEL

£149.99 (car only £96.99)
(autosport.com/shop)

Minichamps' 1:18-scale model of the Red Bull RB7 in which Sebastian Vettel won 11 races and his second successive title comes on a celebration stainless steel plinth with all the relevant stats printed on it. The Renault-powered replica is also available on its own.

HOT ON THE WEB THIS WEEK

YOUTUBE: VILLENEUVE SHOWS WHAT MADE HIM SPECIAL



SEARCH FOR: Villeneuve's wild day in Argentina 1980 (4:26)
Gilles Villeneuve puts the awful Ferrari 312T5 up where it doesn't belong to mix it with Nelson Piquet's Brabham and Alan Jones in the opening GP of 1980. In the end, it cries enough and pitches the French-Canadian off. Classic Gilles!

WHAT'S ON...

Your guide to the best events taking place in the UK and around the world this week – plus TV and online

SNETTERTON (360MRC/HRDC)

May 5-6

Admission: £13 each day

Tel: 01953 887303

The 360 Motor Racing Club provides the headline six-hour endurance race for Classic Saloon and GT cars, while the Historic Racing Drivers Club provides the support races in the form of the Touring Greats, Grand Touring Greats, TC63 and the MGB50.

BRANDS HATCH (MGCC/CSCC)

May 5-7

Admission: £13 each day

Tel: 01474 872331

The MG Car Club joins forces with Porsche Club for a two-day meeting. Then the Classic Sports Car Club takes over in Kent for some Bank Holiday Monday fun.

CASTLE COMBE (CCRC)

May 7

Admission: £15

Tel: 01249 782417

Mini Challenge, 750MC Toyota MR2s, Mini Se7ens and Miglias join Combe's resident FF1600, Saloon, Sports & GT, Classics and Formula Free categories for a Bank Holiday Motors TV live raceday.

SILVERSTONE (BARC)

May 5-6

Admission: £9 each day

Tel: 0844 3728200

Classic Thunder, Legends, Blue Oval Saloon Series, Post Historic/Classic Group 1 Touring Cars, Classic Saloon and Historic Touring Cars, Pre-'93 Touring Cars, Alfa Romeo Challenge, 2CVs and 250cc Superkarts.

KNOCKHILL (SMRC)

May 6

Admission: £12

Tel: 01383 723337

DONINGTON PARK (HSCC)

May 5-6

Admission: £18 each day

Tel: 01332 810048

The second Donington Historic Festival will aim to build on the success of the inaugural event last year. Over 300 cars took to the track in 2011 and bumper grids and competitive racing are expected this year too. Frank Sytner, who suffered a cardiac

arrest at last year's Festival, will return to the fray in his Lola T70. The Festival also includes the pre-war sports cars, Historic F2, RAC Woodcote Trophy for pre-1956 sports cars, Jaguar E-type Challenge, 1966-85 Touring Cars, '1000km' for pre-'72 sports-racing cars, Stirling Moss Trophy for pre-'61 sports cars, Pre-'63 GT, Group C and U2TC Pre-'66 under two-litre tin-tops.

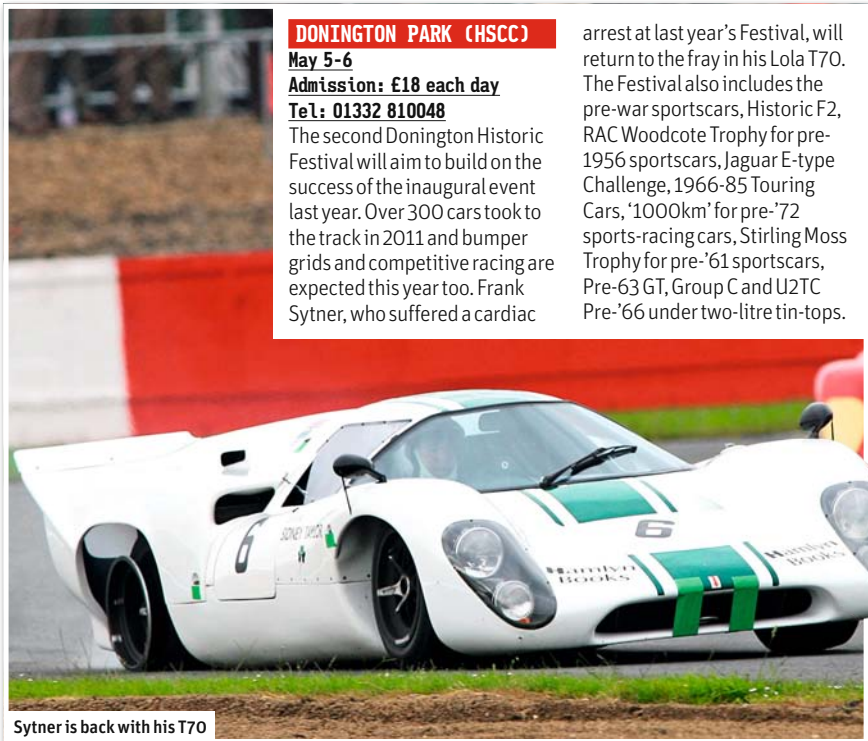

Sytner is back with his T70

FORMULA RENAULT 3.5 SERIES

Rd 1/9

Motorland Aragon, Spain

May 5-6

worldseriesbyrenault.fr

Motorland Aragon plays host to the opening round of the 2012 Formula Renault 3.5 Series. Fortec's Robin Frijns was the pick of a stellar cast during the pre-season testing, topping both days at the Spanish circuit.



Top racing for F1 feeder in prospect

FIA WORLD ENDURANCE CHAMPIONSHIP

Rd 2/8

Spa-Francorchamps, Belgium

May 5

fiawec.com

DTM

Rd 2/10

Lausitz, Germany

May 6

dtm.de

NASCAR SPRINT CUP

Rd 10/36

Talladega, Alabama, USA

May 6

nascar.com

SUPER GT

Rd 2/8

Fuji, Japan

May 4

supergt.net

V8 SUPERCARS

Rd 4/15

Wanneroo, Western Australia

May 5-6

v8supercars.com.au

AUTO GP

Rd 4/7

Hungaroring, Hungary

May 5-6

autogp.org

FIA WORLD TOURING CARS

Rd 5/12

Hungaroring, Hungary

May 6

fiawtcc.com

WTCC stays in Eastern Europe



Television

THURSDAY MAY 3

0030-0130, 0900-1000 **ESPN**
DTM: Hockenheim Highlights
0230-0345 **ITV1**
BTCC: Thruxton Highlights
1135-1340 **Motors TV**
Formula 2: Algarve Highlights
1300-1330 **Eurosport 2**
WTCC: Inside World Touring Cars
1700-1800 **Sky Sports 4**
Racemax

FRIDAY MAY 4

0245-0435 **Motors TV**
Grand-Am: Homestead Highlights
1300-1400 **Sky Sports 3**
Racemax
2235-2340 **Motors TV**
WRC: Argentina Highlights

SATURDAY MAY 5

0900-1000 **Eurosport LIVE**
Auto GP: Hungary Race 1
1030-1100 **ITV4**
DTM: Hockenheim Highlights
1200-1300 **Motors TV**
WRC: Argentina Highlights
1300-2000 **Motors TV LIVE**
FIA WEC: Spa 6 Hours
1330-1430 **Eurosport LIVE**
Formula Renault 3.5: Aragon Race 1
1800-1930 **Eurosport 2 LIVE**
FIA WEC: Spa 6 Hours
1930-2000 **Eurosport 2**
WTCC: Hungary Qualifying
2000-2305 **Motors TV LIVE**
NASCAR Nationwide: Talladega

2000-2130 **ITV4**

BTCC: Thruxton Highlights

SUNDAY MAY 6

0730-0745, 0930-1000 **Eurosport**
WTCC: Hungary Qualifying
0745-0815 **Eurosport LIVE**
WTCC: Hungary Warm-up
1000-1100 **Eurosport LIVE**
WTCC: Hungary Race 1
1130-1230 **Eurosport LIVE**
Auto GP: Hungary Race 2
1230-1400 **BBC2 LIVE**
MotoGP: Portuguese GP
1315-1415 **Eurosport LIVE**
WTCC: Hungary Race 2
1800-2000 **Premier Sports LIVE**
NASCAR Sprint Cup: Talladega
1830-1900 **Eurosport**
Formula Renault 3.5: Aragon Race 2
2100-2305 **Motors TV**
FIA WEC: Spa 6 Hours Highlights
2230-0015 **ESPN**
DTM: Lausitz Highlights
2300-0000 **Eurosport 2**
WTCC: Hungary Highlights

MONDAY MAY 7

0745-0845 **Eurosport**
WTCC: Hungary Highlights
2200-2300 **Sky Sports 2**
NASCAR Sprint Cup: Talladega

Online

AUTOSPORT.COM PLUS

Coming up in our premium web content this week

GILLES VILLENEUVE COMMEMORATION

Tuesday, May 8 is the 30th anniversary of Gilles Villeneuve's death at Zolder, and to commemorate the enigmatic Canadian we're going Gilles crazy on AUTOSPORT Plus. We relive some of Villeneuve's greatest races with some classic race reports and an amazing gallery, while Nigel Roebuck and Simon Strang both reveal why he was a hero to them.



Get AUTOSPORT magazine on your iPad every week

AUTOSPORT MAGAZINE NOW ON iPad

You can now experience AUTOSPORT in digital form on your iPad. It's available all over the world on Thursday morning (UK time) via the Apple Newsstand, and costs just £2.99 for each issue, with further discount available for a subscription. For more info, visit apple.com/uk/newsstand

REVVED UP OVER WHAT'S ON THE BOX

We cast a critical eye over the best and worst of this week's TV coverage



Who's going to rescue the rescue truck?

9AM. GET UP. CUP OF TEA in hand to watch my recording of the NASCAR night race from Richmond. Fast-forward through the cautions at x12. Not a bad race, but bogus caution for a plastic bottle creates an artificial end. That's post-modern sporting entertainment for you.

11.20am. Bacon sandwich. Ready for first Thruxton BTCC race. It's very wet. Race stopped as tow truck gets stuck moving a shunted car. It's a double whammy of incompetence.

12.30pm. MotoGP on BBC2. Build-up to Jerez concentrates on what's up with Valentino Rossi. No one's prepared to

admit the unfortunate truth: that time and injuries have taken their toll and he's now a spent force. The race is really boring. Stoner wins.

1.30pm. Watch recorded highlights of WTCC race one from Slovakia. Chevy doesn't win! Track looks interesting, cars less so.

2.20pm. Back to ITV4 for second BTCC race via a quick look at the footie. Chelsea are spanking QPR. It's still very wet at Thruxton. Safety car start; boring but sensible. Great drive from Gordon Shedden – a class apart.

2.50pm. Watch recording of WTCC race two. This time the Chevys

win, but only just.

3.15pm. Time to get lunch (and fresh air).

4pm. IndyCar on Sky F1 HD. Will it rain? Will the KV drivers crash into each other? No. Will Power takes an easy win.

7.30pm. Have cooked dinner while watching Grand-Am on Motors TV. Deluge means safety car; time to watch the final BTCC race.

7.40pm Tony Gilham leads!?!?

7.58pm. Back to Grand-Am just in time

for the final lap. WRC highlights follow.

9pm. It's part four of the 2002 F1 season review on Sky F1. It's only slightly less tedious than I remember.

10pm. International GT Open rerun on Motors, but it's just filling the gap until the DTM's on ESPN. My eyes are starting to ache. I'm knackered. Then Andrew Marriott's angry shouting wakes me from the beautiful dream in which my TV is broken.

Revved Up

"Watch recorded highlights of WTCC race one from Slovakia. Chevy doesn't win! Track looks interesting, cars less so"

THE WEEK IN PICTURES

Our lensmen pounding the beat, from a bum deal in Argentina to a Slovak tank

LATE TO THE GRID? YOU CAN BORROW MY F-5...

The Sao Paulista fans were entertained by this jet before last weekend's IndyCar race. Bet it had more power than the Lotus...



MOON OUT IN ARGENTINA

Swedes Ramona Karlsson and Miriam Walfridsson got a nasty surprise from this local on the WRC event



MOTOR-SPORT-MUSEUM HOCKENHEIMRING



A NEW ERA AT HOCKENHEIM

BMW is back in the DTM, but we're not sure that aficionados of Merc or Audi would have been too keen on the blocked view

TARQUINI LIKES THE ROUGH STUFF

SEAT's WTCC hero finds a new weapon - this communism relic - in Slovakia to biff those pesky Chevys off-track



NEXT WEEK

SERGIO PEREZ THEY ALL THINK HE'S OFF TO FERRARI; IS HE GOOD ENOUGH? **DON'T MISS IT!**

FROM THE ARCHIVE

Gilles Villeneuve and the Trois Rivieres street race



“On the streets of Quebec Villeneuve’s success was expected to stop, with James Hunt in the race’s line-up”

Villeneuve leads Tom Klausler, Bobby Rahal and Brambilla

“GOING INTO THE SECOND CORNER, THERE WAS absolutely no rear brakes. I tried to throw the car through the corner, and I almost made it...”

So said Gilles Villeneuve, shortly after crashing out of the Trois Rivieres Formula Atlantic event in 1975. It was a race that in many ways epitomised the man: on a scraped-together budget and in below-par machinery he was still able to qualify on the second row and then battle with visiting stars Jean-Pierre Jarier and Patrick Depailler, running within the top three for much of the race.

His engine, and his challenge, faded as the race neared its end, and then on lap 47 he was out, his brakes suddenly fading – although in typical Villeneuve fashion his immediate reaction was to try and throw the car through the corner. “I almost made it,” he explained, “but the left-front corner nicked the wall.”

The premature exit meant the headlines went to Jarier and Vittorio Brambilla, but Villeneuve’s exploits at Trois Rivieres – both in 1975 and the following season – were instrumental in propelling him forward in the consciousness of the wider motorsport world.

Several offers from top Atlantic teams came in for the ’76 season, and he opted for Ecurie Canada, where he had secured a seat two years earlier by selling the family home.

The match yielded instant success, and by Trois Rivieres – the traditional end to the Atlantic season – Villeneuve had won four times and claimed pole for five straight races. On the streets of Quebec that success was expected to stop, as event organisers assembled the best line-up in the race’s history, including soon-to-be-world-champion James Hunt.

But there was no question about it: in an Atlantic car, and through the Canadian streets, Villeneuve was faster than anyone. His March claimed pole by more than three tenths of a second, he protected his lead at the start and then simply edged away from the field.

By one-third distance his advantage over Brambilla stood at eight seconds, and it remained around that mark until the closing stages when his engine began to splutter and a charging Alan Jones, who had started seventh, closed in. In typical fashion Villeneuve attacked again, scything through traffic on his way to a winning margin of over 10s.

It was a dazzling performance, and led to Hunt pointing McLaren in Villeneuve’s direction. One year later he made his F1 debut for the British squad at Silverstone, before a call came from Ferrari. On home soil, almost exactly 13 months after the Three Rivers, he started his first F1 race as a Ferrari man. ❧

THIS WEEK IN...



MAY 5 1977

BOB WOLLEK AND HANS STUCK conquered the Nurburgring in the Group 5 DRM this week in 1977.

While Group 5 was struggling at world level at the time, entries in the German national series remained strong and the race was divided into two categories, the more-powerful over-two-litre contenders starting five minutes before the smaller machines.

Wollek was a dominant force in the higher category, qualifying his Porsche 935/2 almost two seconds clear of the field before romping to a 34s victory after seven laps. Stuck could not match that margin in Division 2, but did manage to lead home a frantic pack battle from which Marc Surer and Eddie Cheever eventually emerged to seal a BMW 1-2-3.



PICTURE: MURENBELD/LAT



The Ultimate Fantasy Grand Prix Game
PLAY NOW – it’s FREE WINGREATPRIZES

predictor.castroledgerankings.com

Castrol
EDGE
GRAND PRIX
PREDICTOR



VINCENZO SOSPIRI

■ Grand Prix de Pau ■ Reynard 93D-Judd ■ May 31, 1993 ■ Charge to P6 from a pitlane start, with no rear brakes!



Sospiri hauled the Mythos Reynard to P6

CHOOSING A RACE OF MY LIFE is difficult, as I did so many races. Even if I didn't win, sometimes I felt I did a fantastic job. I had a special time in Formula Ford with John Village in 1988. I was living in England for the first time and the team treated me really well. I remember my first win at Oulton Park. It was only my second ever Formula Ford race, and I won by 14 seconds in a 10 or 12 lap race. The car was just fantastic. The Formula Ford Festival win at the end of the year was also very special, as there were so many strong drivers from all over the world.

In any race I always felt I gave my maximum, but the Pau F3000 race in 1993 was something incredible. I had gone back to Italy in '92 to do F3 as I had run out of budget. At the start of '93 season, I still didn't have enough money for F3000, but I managed to put together a deal to race for the Mythos team a week before the first race of the season.

The team was formed by many people from the Il Barone Rampante team, which had run Alex Zanardi a couple of years

"After three laps I had no rear brakes. To slow the car down I only had use of the front brakes and the gearbox. But I was still able to pass quite a lot of people"

before, and had moved over when backer Giuseppe Cipriani pulled out. The mechanics at Mythos went to England in the week before the first race to finish building my Reynard and then went straight to Donington for round one.

By Pau, we were fast. But after the first lap there was a big crash

on the straight. There was a red flag and everybody stopped. I think Gil de Ferran caused the red flag. David Coulthard, myself and another car were pushed onto the kerbs. It was a really strong year, as there were also people like Pedro Lamy, who won the race, and Olivier Panis, who won the title.

IN PROFILE



FORMER KARTING ACE VINCENZO

Sospiri won the 1988 Formula Ford Festival and graduated to F3 with uncompetitive equipment. He salvaged his career with the 1990 Vauxhall Lotus title and a long stint in F3000 was rewarded with the crown in 1995. A spell as an F1 test driver with Benetton preceded a failed attempt to qualify for the '97 Australian GP for Lola. He took International sportscar titles in 1998 and 1999 then set-up Euronova Racing for Auto GP, Italian F3 and FAbarth.

Anyway, the accident happened and I had to make the restart from the pits. They repaired my car very quickly in the pitlane. There was one brake duct broken, and it was really needed to cool down the rear brake. As the team couldn't fix it, someone decided that they would break the one on the other side to make it even!

After three laps I had no rear brakes. To slow the car down I only had use of the front brakes and the gearbox. But I was still able to pass quite a lot of people, and around a street circuit like Pau that's not usually easy.

Then the rear brakes got so hot that certain parts got disconnected from the metal. At the end of the race the parts of metal were in two pieces. It was incredible, but I finished sixth. The mechanics took one look at the back of the car after the race and said, 'How on earth can you drive like this?' I said, 'I don't know, I just drove it!'

I eventually got my first F3000 win with Super Nova in Barcelona in 1995 – and that was good, too. *Vincenzo Sospiri was talking to Peter Mills*



SPECIALISTS IN THIS EVENT OFFICIAL AGENT WITH ACCESS TO THE BEST CAMPSITES AND GRANDSTAND SEATS

Le Mans 24Hours 16th - 17th June 2012

Circuit Campsites

Bleu Nord, Bleu Sud, Beausejour, Expo & Interior Musee
all available to book NOW

Off Circuit Camp Sites

Circuit car parks all still available
General Admission

Grandstand Seats

Pits, Dunlop, Barnato, Benoist, Chinetti & La Sarthe still available

Le Mans Classic 6th - 8th July 2012

On or off circuit campsites

General admission
Grandstand Seats
Paddock passes

For immediate booking

Call: +44 (0)1304 228866 or Fax: +44 (0)1304 242550

Visit our website on www.justtickets.co.uk

sales@justtickets.co.uk | info@justtickets.co.uk



BY APPOINTMENT TO
HER MAJESTY THE QUEEN
SUPPLIER OF CAR CARE PRODUCTS
AUTOGLYM, LETCHWORTH, ENGLAND



BY APPOINTMENT TO
HRH THE PRINCE OF WALES
SUPPLIER OF CAR CARE PRODUCTS
AUTOGLYM, LETCHWORTH, ENGLAND

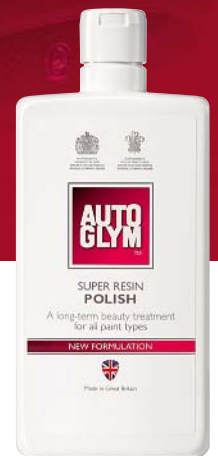

A Master Redefined.

Autoglym Super Resin Polish has been the UK's leading car polish for over 25 years. In 1986 it heralded a revolution in car care and now the all-new formulation is once again raising the standard. The new advanced Autoglym Super Resin Polish boasts unparalleled performance: an even deeper shine, superior beading and unprecedented durability. The pinnacle in car care.

The new formulation surpasses its multi-award winning predecessor and all known rivals. It delivers more than twice the durability of its closest competitor. A testament to Autoglym's unbeatable quality is exclusive recommendation by an ever increasing number of the world's leading car manufacturers, including Jaguar, Aston Martin Lagonda and Bentley.

To experience the ultimate results, ask your retailer for the limited edition Autoglym Super Resin Polish packs that include a complimentary premium Autoglym Hi-Tech Finishing Cloth.

For more information visit www.autoglym.com



Made in Great Britain



Reflecting
the best of British