



Linea gioco - Playground

Chi Siamo

FPGroup offre servizi di ottima qualità nell'ambito dell'impiantistica sportiva e ricreativa per comunità. Grazie alla notevole affidabilità dei suoi prodotti, l'azienda dispone delle più appropriate, moderne ed economiche soluzioni per la realizzazione e la progettazione di pavimentazioni sportive e di sicurezza antishock, impianti sportivi, parchi gioco infantili, aree d'incontro per l'attività motoria e ricreazionale, siano esse di pertinenza di strutture sociali o di grandi complessi residenziali.

L'azienda progetta campi gioco per spazi pubblici, asili, scuole, ospedali, studiati a livello interdisciplinare con l'apporto delle più recenti conoscenze di psicologia infantile.

Le tecnologie adottate, unite all'esperienza di personale qualificato, permettono di avere un prodotto di qualità, certificato e duraturo nel tempo.

Sicurezza, qualità, attenzione alle esigenze sempre più diversificate dei clienti, sono i punti forti di un'azienda dinamica, competitiva e conforme alle normative ISO 9001:2000 e ISO 14001.

About us:

FPGroup offers high quality services in sports and recreation equipment for both indoor and outdoor environments. Its products are produced with a high standard in quality of materials and durability for the expected vigorous usage by children of all ages.

Their playgrounds and equipment are designed to be modern, robust and produced with economical solutions which offer anti-trauma flooring safety as a primary consideration in any environment – whether that is sports facilities; children's playgrounds; hospitality establishments with play areas; and recreational residential areas.

The Company does not only design playgrounds and equipment for parks; public areas, but also for kindergartens; schools and hospitals. Having researched and studied at intermediate disciplinary level with a focus on child psychology in order to gain the knowledge required to ensure that its playgrounds and equipment are well suited to the needs and educational social advancement of children through the fun of playing together.

Integrating technology with their design team's experience creates the possibility to offer a quality long-lasting certified product.

The needs of customers with diversified requirements dictates that the importance of attention to the details for safety and quality reflects the strong points of FunPlay as a dynamic competitive company in the market, which complies with regulations ISO 9001:2000 and ISO 14001.





Perchè scegliere Funplay?

1. Montarlo è un gioco da ragazzi

Ogni gioco è disegnato per essere assemblato con semplicità: grazie al suo particolare giunto strutturale è possibile comporre ogni combinazione in un attimo.

2. Disegnato per un trasporto facile

Gli elementi sono facilmente stoccabili e comodi da trasportare.

3. Tutto a norma

Tutte le combinazioni sono state sviluppate secondo le normative di sicurezza EN1176, EN1177 e le certificazioni di qualità ISO 9001 e ISO 14001.

4. Per tutti i tipi di pavimentazione

Funplay offre una larga scelta di pavimentazioni antitrauma, appositamente sviluppate per essere installate con il gioco.

5. Pochissima manutenzione

Ogni componente FPGroup è stato studiato e realizzato per garantire durata nel tempo e facilità di manutenzione.

6. Opere murarie da dimenticare

Ogni problematica di preparazione del sottofondo viene ridotta al minimo grazie alle nostre soluzioni.

Why Choose FPGroup?

1. Quite simply to put it all together.

All of the play activities are designed to fit together easily. Thanks to the particular structural joints that make the assembly quick for every combination of FPGroup.

2. Designed for easy Transportation.

The elements are easily stored and simple to transport

3. Everything is regulated by the Law.

All the combinations of FPGroup are developed following the Strict Safety Instructions EN1176; EN1177 and the Quality Certifications ISO 9001 and ISO 14001.

4. For all kind of flooring

FunPlay offers a great choice of anti-trauma flooring specially studied to be put together with the play.

5. Minimum Maintenance

All FunPlay components have been sourced and developed to ensure a long lasting endurance over time with minimum maintenance.

6. Building works to be forgotten

All problems of the sub-floors are minimized thanks to our solutions





Pannelli HDPE
HDPE Panels



Elementi rotostampati
Elementi rotostampati

I nostri materiali Creati per durare

Il nostro sistema di verniciatura e trattamenti è la risposta più esauriente per soddisfare le diverse esigenze di utilizzo e le relative durabilità che si desiderano ottenere da un trattamento per manufatti in acciaio. Ideale se si intende contrastare difficili condizioni ambientali, come ad esempio quelle marine, e ottimo se l'intenzione è di ottenere una migliore finitura cromatica senza rinunciare alla massima protezione.

Protezione

La protezione dei manufatti in ferro è un aspetto che non va sottovalutato: un manufatto correttamente progettato e costruito, presenta una vita più lunga.

La zincatura a caldo realizza uno strato di lega acciaio-zinco che protegge radicalmente il manufatto, difficile da scalfire, sia sulle superfici esterne sia su quelle interne, tipiche dei profili in tubo impossibili da proteggere con altri trattamenti.

L'abbinamento ad un ciclo di verniciatura dedicato consente di creare sistemi protettivi adatti a tutte le condizioni ambientali in grado di raggiungere durabilità elevate, minimizzando gli interventi manutentivi.

Our Material Created to last

The paint and steel treatment system, which the Company uses, is the most advanced and effective solution for satisfying the sustainability and durability needs for the equipment. This system protects the equipment in any kind of environment or local climatic conditions such as high humidity and strong sunlight that can fade the colours of paint: or a near proximity to coastal sea waters, where normally the salt in the air would corrode the equipment.

Protection

The protection of the steel equipment is an important aspect not to be underestimated. They are designed and built with Nanotechnology which creates the evolution of the system with innovation in pre-treatment and frequently redoing of melting baths of our painting system. Our mission is to grant a long life product through a good quality painting in its specific context.



Funplay with color



Pavimento FunShock

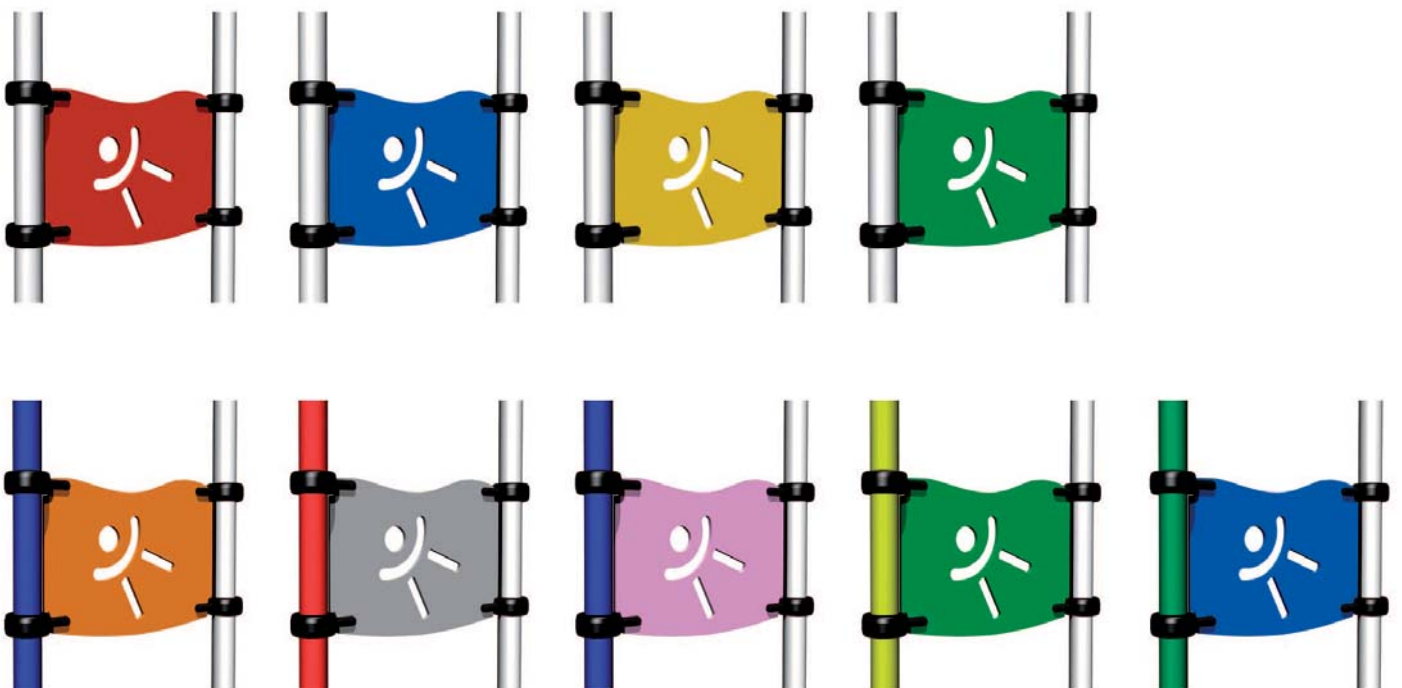

Componenti in metallo

Prestazione

La nanotecnologia, l'evoluzione degli impianti, l'innovazione nei pre-trattamenti e l'affinamento continuo dei bagni di fusione del nostro sistema di verniciatura e trattamenti garantiscono un'imbattibile performance di durabilità.

Performance

Nanotechnology, evolution of the system, innovation in pre-treatment and frequently re-nig of melting baths of our painting system ensure a long life to all our products

Perfezione

Verniciare un manufatto significa consentire il suo migliore inserimento nel contesto dell'opera e fare in modo che questo si conservi negli anni.

Perfection

The Company's mission is to produce good quality products that offer our clients the advantage of a system, which prevents such damage and guarantees a longer-lasting protection.

Nanotecnologia all'opera

Le tre fasi che compongono il nostro sistema sono state perfezionate grazie alle nanotecnologie: un bagno di zinco appositamente studiato per essere verniciato, un pretrattamento in perfetta compatibilità con la lega di zinco e vernici speciali riformulate per il supporto zincato. Un ciclo completo e interconnesso in ogni sua fase a garanzia dell'aderenza del film di vernice al metallo. Un processo essenziale per una finitura d'eccellenza.

Nanotechnology at work

Our system comprises of 3 Phases improved by Nanotechnology which is a coating of zinc purposefully applied as a pre-processing step in perfect compatibility with the alloy of zinc and special paints adapted to the zinc sheets reformulated for the galvanized zinc support. A complete cycle interconnected in its every phase to ensure the coating attaches perfectly to the metal - a necessary process for an excellent finish.





FPGROUP è specializzata nella:

- Realizzazione di pavimentazioni sportive e di sicurezza antishock per: parchi giochi infantili, campi da basket, piste di atletica leggera, campi da golf, campi pratica golf e driving range, pavimentazioni per l'equitazione, campi da tennis, campi da calcetto
- Progettazione e realizzazione di zone ricreative
- Allestimento di parchi giochi, completi di: altalene, scivoli, strutture di arrampicata, animali a molla, giochi multi proposta con torrette e torri scivolo conformi alle norme EN 1176 e EN 1177
- Allestimento di parchi e giardini e di zone di sosta
- Vendita di piastre polivalenti per pavimentazioni specifiche per parchi gioco
- Progettazione e vendita di due linee di gioco: FunArena costituita da arene multi sportive e poli funzionali ideale per qualsiasi attività sportiva Funplay, giochi ad uso esterno ed interno per bambini di ogni fascia di età
- Arredo urbano: panche, fontane, fioriere, cestini per rifiuti, posacenere, giochi d'acqua

FPGROUP specializes in:

- Construction of sports flooring and safety antishock: childhood playgrounds, basketball courts, athletics tracks, golf courses, practice golf course and driving range, flooring for horse riding, tennis courts, soccer fields
- Design and construction of recreational areas
- playgrounds interior, complete with: swings, slides, climbing structures, spring animals, multi proposal games with turrets and towers slide comply with EN 1176 and EN 1177
- Preparation of parks and gardens and parking areas
- Sale of multipurpose plates for flooring specifications for playgrounds
- Design and sale of two lines of play: Funarena consists of sports arenas and multi functional poly ideal for any Funplay sports activities, outdoor and indoor games for children of all ages
- Street furniture: benches, fountains, flowerpots, trash cans, ashtrays, water games





Missione

FPGroup grazie alla specifica esperienza nell'ambito dell'impiantistica sportiva e ricreativa per comunità, si dedica con estremo impegno e professionalità alla progettazione e alla sistemazione di aree di incontro fornendo tutte le attrezzature necessarie per l'attività ludica, motoria e ricreazionale, destinate alle aree di gioco en plein air, ai luoghi di incontro e ai grandi complessi residenziali.

Si avvale di un importante staff di collaboratori con differenti incarichi che garantiscono la qualità dei prodotti e delle tecniche di lavorazione.

In particolare offre costantemente:

- controllo e monitoraggio delle strutture
- controllo e monitoraggio stoccaggi delle materie prime
- controllo della rapidità dei trasporti
- prevenzione e lotta agli incendi
- sicurezza delle macchine
- illuminazione e microclima
- protezione dei manufatti e delle macchine
- posizione ad altri agenti
- controllo sanitario
- verifica documentazioni e statistiche
- tutela dell'ambiente (rifiuti, scarichi, emissioni, rumore, formalità)

Qualità e Ambiente

L'azienda ha ottenuto le certificazioni di qualità ISO 9001 e di gestione ambientale ISO 14001.

Mission

Thanks to their special knowledge, techniques and experience in working with sports facilities and recreational communities, FPGroup put a great deal of effort and passion into planning and arranging communal areas by supplying all of the equipment for motor playing and recreational areas designed for playing and open air areas for communal use in large housing estates.

The Company employs an important team of collaborators with different tasks who ensure the quality of the products and processing techniques.

In particular it constantly offers:

- a monitoring and control of equipments
- a monitoring and control of the raw material storage
- a control of the speed transport
- the fighting and prevention against of fire
- the safety of machines
- the lighting and microclimate
- the security of machines and equipments
- the security against different atmospheric agents
- a sanitary check
- the verification of documents and statistics
- the protection of environment: (waste discharges, noise emission, chemical actions)

Quality and environment:

The Company has received ISO 9001 and ISO 14001 for quality and environmental management system





Funplay Nuvola

Utilizzabile come base per le strutture gioco o come seduta confortevole e colorata.

Un nuovo sistema di ancoraggio.

Progettata per ottimizzare il sistema di posa evitando le tradizionali fondazioni in calcestruzzo.

Can be used as a base for gaming facilities or a stool comfortable and colorful.

A new anchoring system.

Designed to optimize laying system avoiding the traditional concrete foundations.

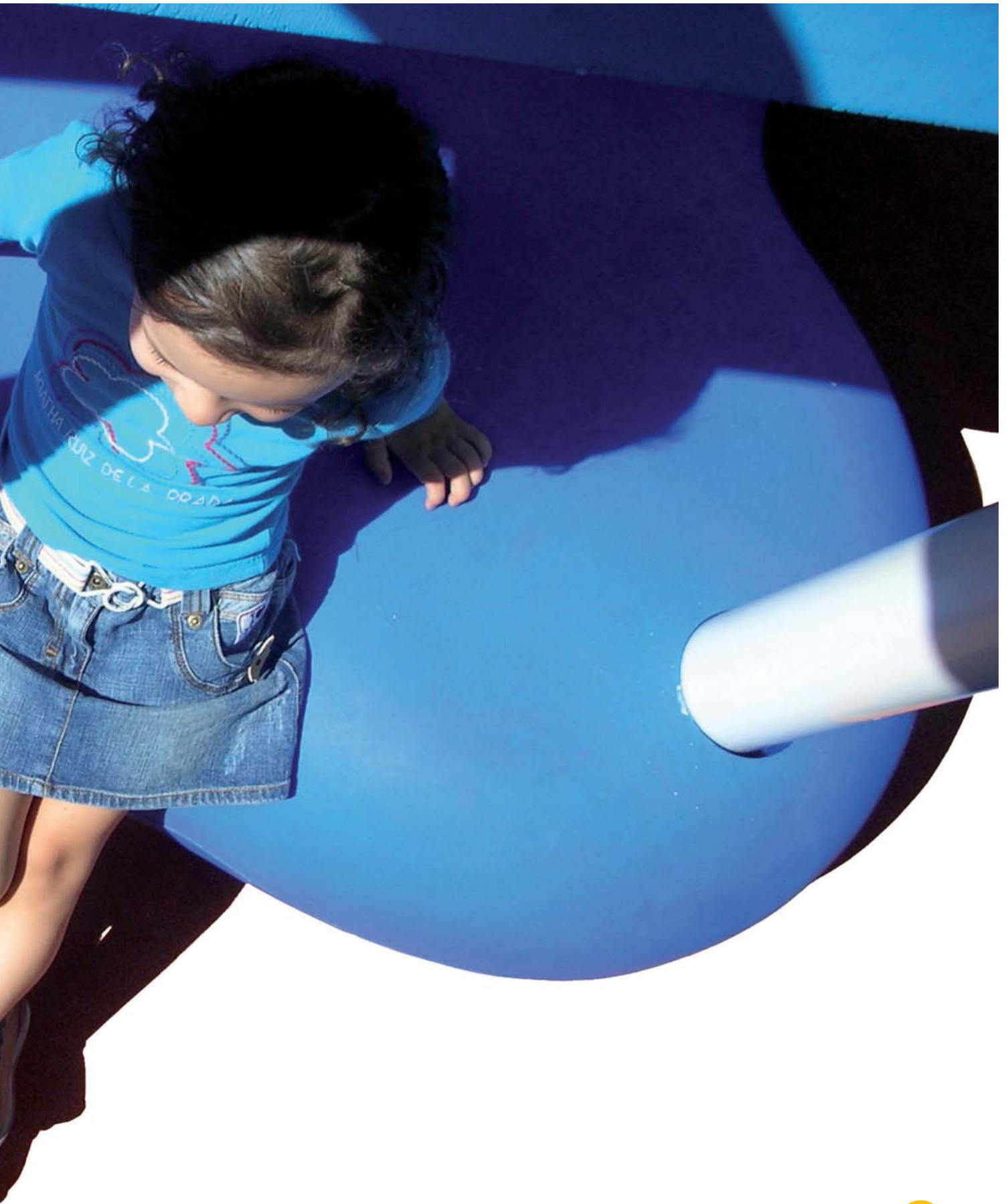



Funplay Nuvola

Risulta essere una seduta comoda ed ergonomica grazie alle sue forme sinuose

A comfortable and ergonomic sitting due to its winding shapes

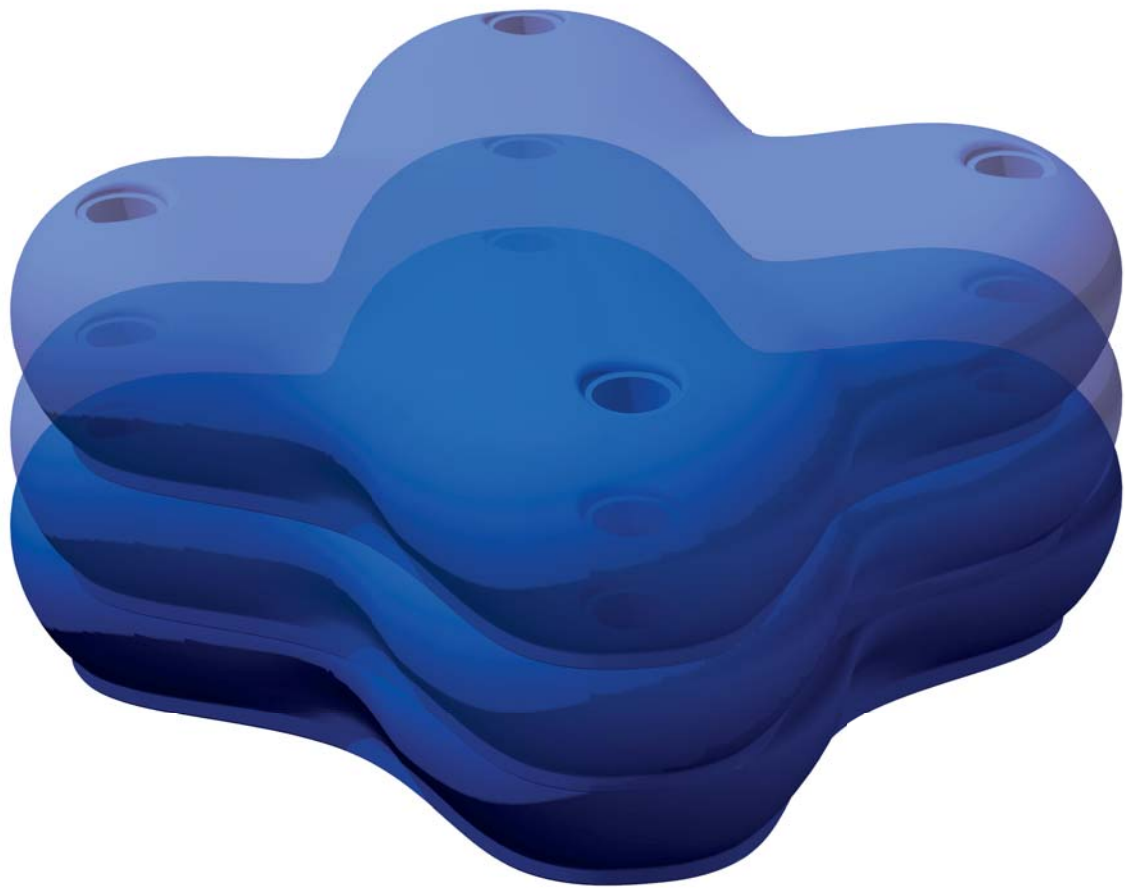

Il nuovo sistema di fissaggio ha al suo interno una "vasca",
dove viene depositato il materiale inerte per creare la
zavorra

This new anchorage system is made up an
inner element filled by inert material with
ballast function

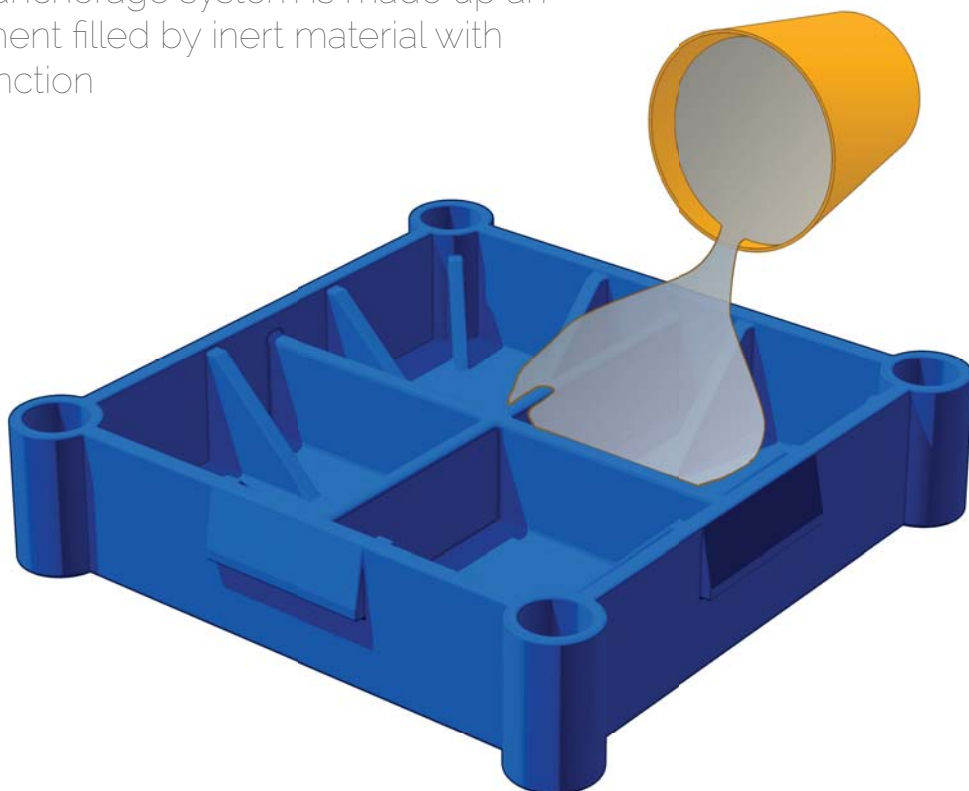

QATAR_Al Khor - Progetto Parco Interattivo



Interactive playground area Project



Serravalle Outlet - Parco giochi

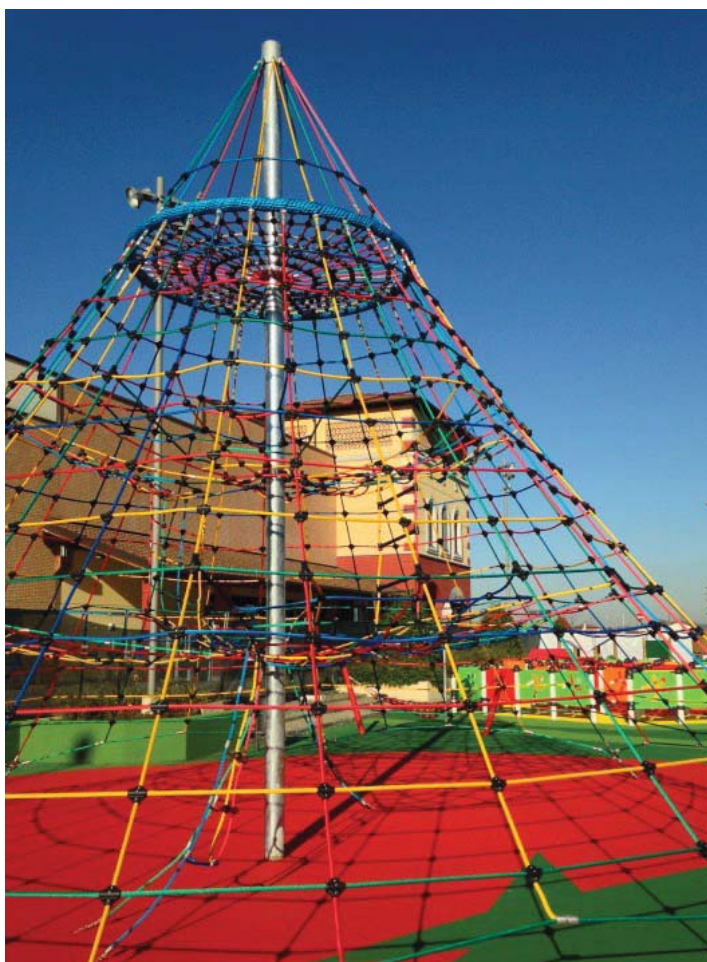

Playground Area for Serravalle Outlet



UAE_Sharjah - Pavimentazione anti-trauma

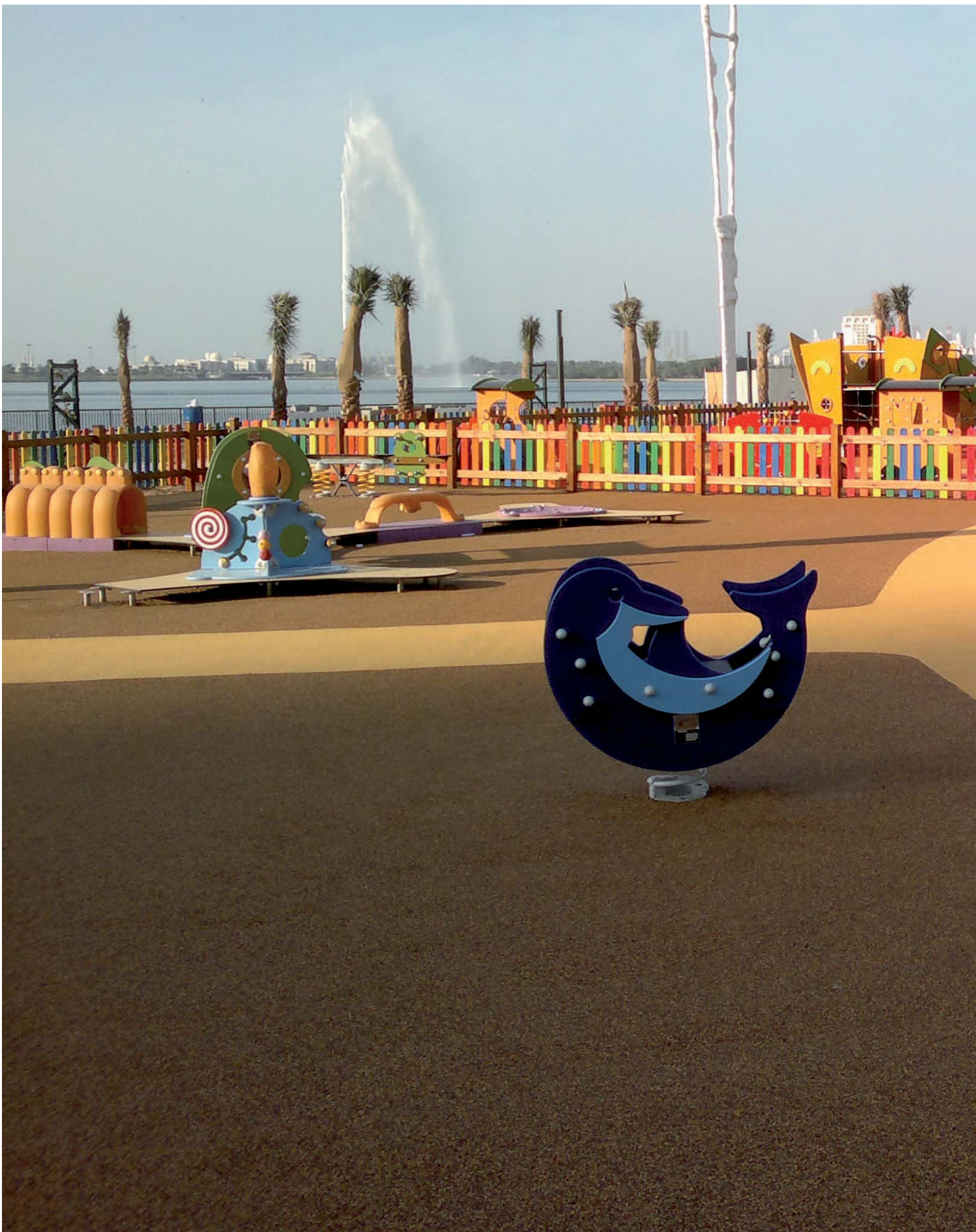

Realization of Anti-Shock surface



Germania_Bad Kissingen - Parco giochi al coperto



Indoor Playground Area in Germany



Milano - Giardini Expo 2015 - ingresso principale area espositiva



Main entrance garden Expo 2015



Milano - Expo 2015 - Children Park





MILANO 2015





Milano - Triennale di Milano_Museo del Design



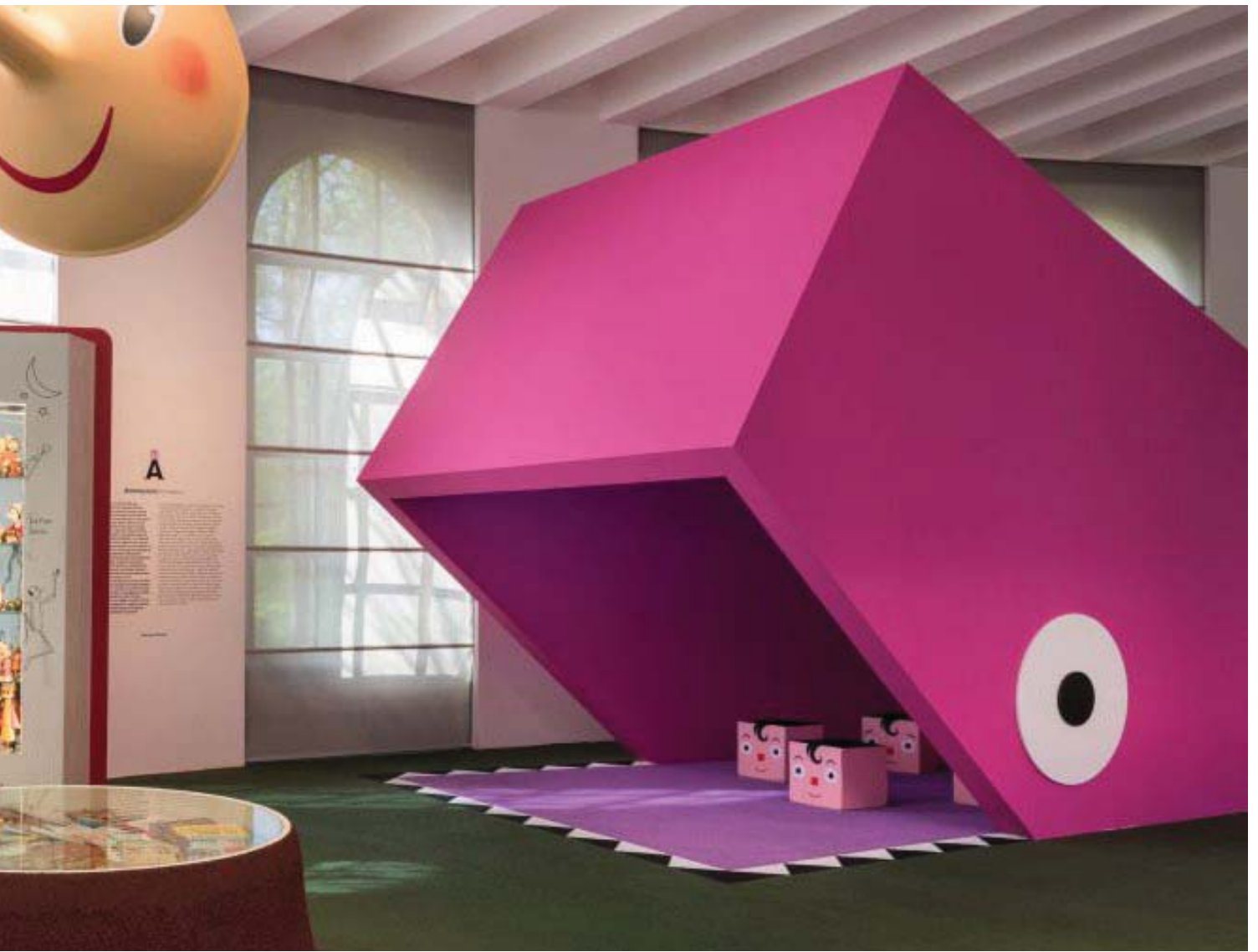

Comune di Lodi - Parco Giochi Piazza Albarola



Playground Area Albarola Square



Comune di Lomazzo - Arena Multisport



Multisport Arena



Dubai - Swiss School of Dubai - Giardino interno della Nursery



Indoor Nursery Garden



Utilizza FunSHOCK per pavimentare il tuo Training Camp



Use FunSHOCK for your Training Camp surface





I nostri prodotti

Fun Play Trepù

pag. 44 - 101

La linea allegra e colorata che attraverso il gioco, stimola le capacità psico-motorie e le relazioni dei bambini a partire dai 3 anni in su.

The nice and colored line which through the use of games stimulates psycho motor and relationship functions starting from 3 years

Fun Play Stella

pag. 102 - 147

La linea leggera e dinamica, composta da arrampicate e reti che rendono il gioco estremamente attivo, libero e stimolante.

The dynamic and lightweight line with climbing and networks, that make the game extremely free active and exciting

Fun Play Bimbo

pag. 148 - 163

La linea pensata per i più piccoli! Dalle forme morbide e sicure nascono percorsi guidati e interattivi che creano stupore e divertimento in un mondo di colori.

The line designed for kids! From soft and comfortable and safe lines arise educational and interactive tours which shows fun and surprise all over the world.

Fun Play Arena

pag. 164 - 179

Arene sportive flessibili pensate per dare la possibilità di praticare diversi sport garantendo la miglior combinazione di sicurezza e divertimento e interattivi che creano stupore e divertimento in un mondo di colori.

Flexible sport arenas designed to give the opportunity to practice different sports assuring the appropriate mix of safety and fun

Fun Play Tema

pag. 180 - 217

Grazie ai pannelli tematizzati, i giochi si trasformano in montagne, castelli e macchine immaginarie stimolando la fantasia di ogni bambino di sicurezza e divertimento e interattivi che creano stupore e divertimento in un mondo di colori.

Thanks to themed panels the games turn into mountains, castles and imaginary machines stimulating imagination of all kids

Fun Play 4D

pag. 218 - 235

Una nuova linea composta da morbide forme su cui arrampicarsi e sviluppare il senso di equilibrio divertendosi.

A new line with new soft shapes to climb, in order to develop the sense of balance

Fun Play Shock Pavimentazione

pag. 236 - 257

Pavimentazioni in gomma antitrauma per garantire sicurezza, eleganza e colore nei parchi gioco e nelle aree delle nostre città.

Anti-shock rubber floorings to ensure safety, elegance and color in the playgrounds of our towns

Fun Play arredo

pag. 258 - 273

Elementi di arredo urbano per aumentare, con eleganza, il comfort in città.

Some elements of urban living to increase with elegance the living comfort







fun
PLAY
trepiù 3+

COMBINAZIONI CLASSICHE

La Linea 3+ è pensata per guidare i bambini tra percorsi colorati, divertenti e dinamici. Ponti, arrampicate, risalite, discese e scivoli per il divertimento di ogni bambino!

CLASSIC COMBINATIONS

Funplay line 3+ is designed to lead children toward colored fun and dynamic tours . Bridges, climbing, rising, descents and slides for fun of every child!







Public Gardens





Pannello
Negozio



Pannello
Labirinto



Pannello
Specchio



Pannelli Didattici

Linea di pannelli didattici indispensabili per un progetto ad alto valore ludico ed accessibile



Pannello
Lavagna



Pannello
Musicale



Pannello
Didattico



Educational Panels

This educational panels line is essential for an highest value and accessible project



**Pannello Musicale
Xilofono**



Gioco Stella



Gioco Tris

Struttura inclusiva con pannelli interattivi



Pannelli realizzati in Polietilene ad Alta Densità (HDPE) con sistema gofrato difficilmente attaccabile da vernice e graffi

Inclusive structure with interactive panels



**Pannello Musicale
Campane**



Gioco Automobile



Gioco Musicale

Panels made of High Density Polyethylene (HDPE). Goffered system result hardly vulnerable by paints and graffiti





Elicottero su molle
Helicopter on springs



Aula all'aperto con sedute a fungo in EPDM
Outdoor area with Mushroom sittings made of EPDM

Dubai_UAE

Swiss International Scientific School

Strutture in polietilene resistente ai raggi UV e con goffratura antigraffio.

Structures polyethylene UV resistant and scratch-resistant embossing.





Comune di Ghedi - Prodotti certificati EN 1177 e EN 1176

Combinazione di attrezzature da gioco e di superficie antishock per i parchi pubblici del Comune di Venezia

Combination of playground equipment and antishock surface for the public parks of the Municipality of Venice





Comune di Lodi - Altalena Inclusive Play

Progetti pensati per il gioco inclusivo con facili accessi e strutture dedicate.

Projects designed for inclusive play with easier accesses and dedicated structures.



Comune di Parabiago (MI) - Pedana per torre inclusiva

Combinazione con pannelli interattivi e grande pavimento con pedana d'accesso



Parabiago - Inclusive tower with accessible Platform

Interactive panels posed on a large platform accessible by a stand

Percorsi colorati, divertenti e dinamici per guidare i bambini





Giochi a molla



FPM 0001



FPM 0002



FPM 0003



Spring games

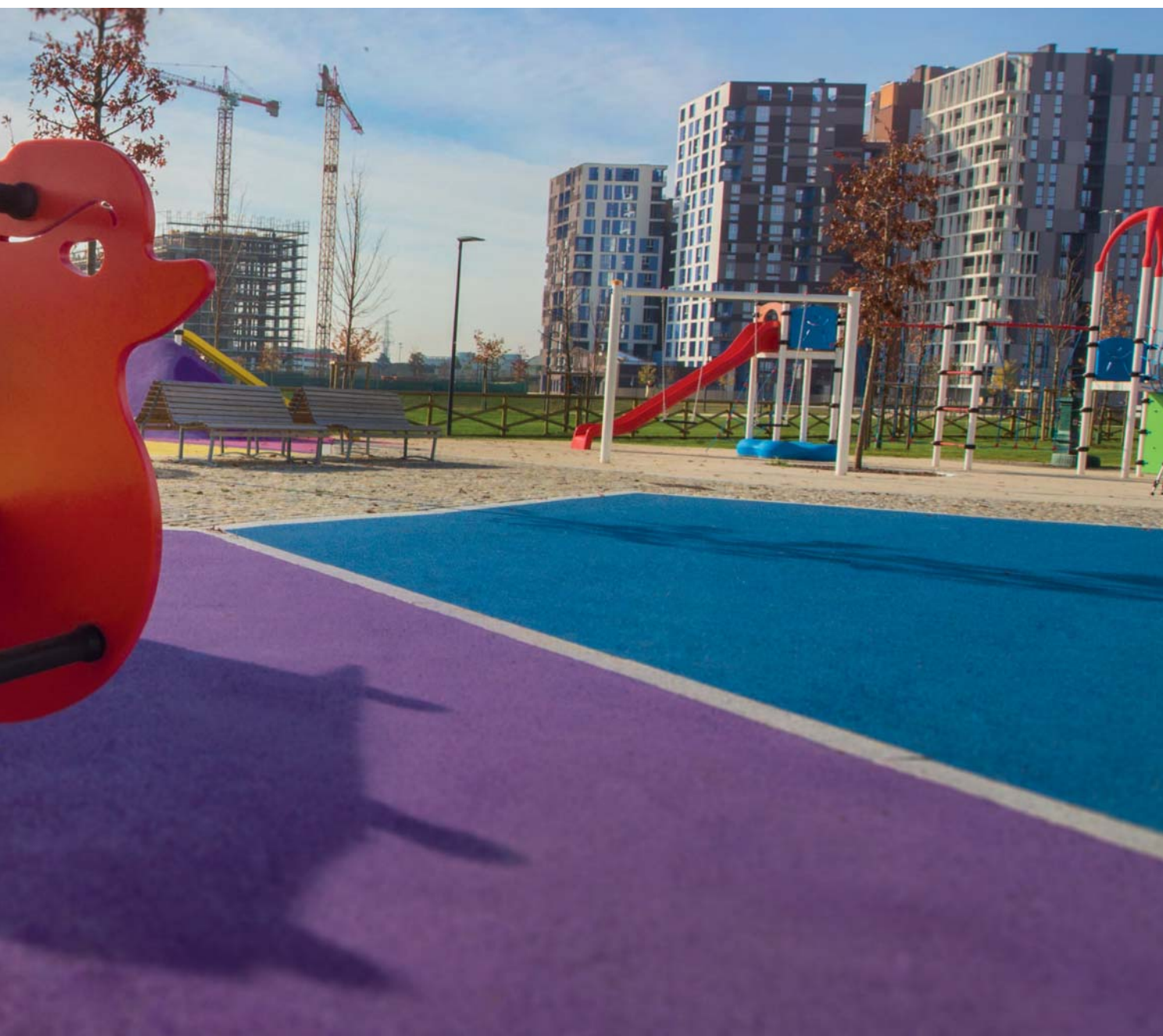

FPM 0004



FPM 0005

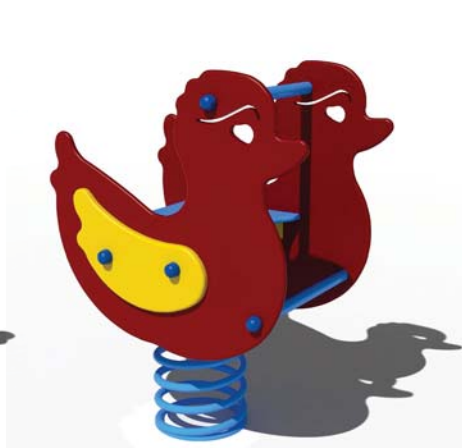

FPM 0006



FPM 0100 - Molla danzante_Face to Face dancer



Il gioco a molla di grandi dimensioni per un grande divertimento tutto in sicurezza.

Progettato per due persone e costituito dalla seduta in LDPE realizzata con le più moderne tecniche di stampaggio rotazionale. Manici e molle in acciaio zincato.

The large spring game for most fun in complete safety.

Designed for two peoples consists of LDPE seat realized by latest rotational moulding technologies. Handles and springs made of galvanized steel



COLORI DISPONIBILI:    

AVAILABLE COLOURS:



FPM 0101 - HULA HOP_HULA HOP Dancer



Aumentano i giocatori, aumenta il divertimento. Tutto in estrema sicurezza.

Progettato per più persone e costituito da una seduta ed un volante realizzati in LDPE. Il montante centrale e le molle sono in acciaio zincato.

Increasing players, fun gets bigger. Always in complete safety.

Designed for few peoples consists seat and wheel LDPE made of. Main pole and springs made of galvanized steel and powder coated



COLORI DISPONIBILI:
AVAILABLE COLOURS:



Comune di Arconate (MI) - Nuovo parco giochi di Via Silvio Pellico



New Playground area for Municipality of Arconate



DIVERSI TIPI DI SEDUTA!



Seggiolino a tavoletta



Seggiolino a cesto



Seggiolino a cesto



Seggiolino a gabbia







COLORI DISPONIBILI

Una gamma di colori vivaci che si adatta ad ogni contesto

COLOURS AVAILABLE

A wide range of lively colours that adapts in every context

SICUREZZA

Le sedute sono specificatamente modellate per offrire comfort e sicurezza per tutti i bambini

SAFETY

The seat is specially modelled and the technology of production provides comfort and safety to all children



50002B-sa - Seduta a cestone_Nest seat

Una seduta inclusiva e adatta ad ogni età per divertirsi in compagnia

An INCLUSIVE seat suitable for all ages for having fun in company



Realizzata in polietilene a bassa densità (LDPE) tramite stampaggio rotazionale. Una seduta per altalene destinata a parchi pubblici e privati, è progettata per essere durabile nel tempo e per più utilizzatori.

LDPE bird nest seat is realized by rotational moulding and is intended for swings on public playgrounds. It's characterised by high durability and is designed for several users

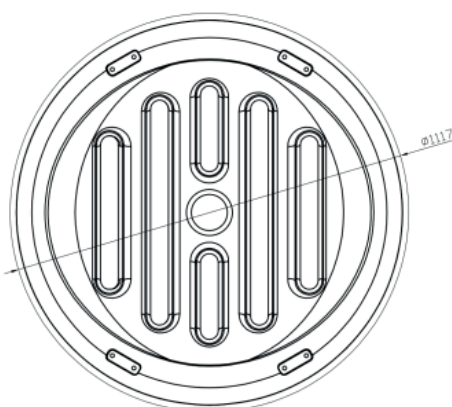
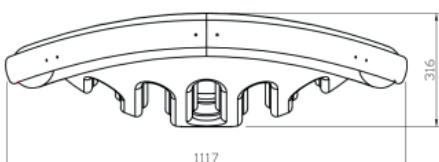

DIMENSIONI

Ø complessivo: 1117 mm
Altezza: 316 mm

Fornita con catene in acciaio zincato

DIMENSIONS

Ø overall: 1117 mm
Highest: 316 mm

Provided galvanized steel chains

50004-sa - Seduta inclusive_Seat for the disabled



Materiali

Plastica LDPE colorato, imbottitura in EPDM a lato

Materials

Dyed LDPE plastic, impact-cushioning EPDM rubber on the sides.

Misure

Lunghezza 610 mm

Larghezza 592 mm

Altezza 937 mm

Standard di sicurezza EN-1176-2

Technical

Length 610 mm

Width 592 mm

Height 937 mm

Safety standard EN-1176-2

Caratteristiche

La seduta è realizzata con la tecnologia rotostampata del LDPE. È adatta per le necessità dei disabili. La moderna e resistente struttura garantisce comfort e sicurezza. Una cintura impedisce la caduta.

Characteristic seat

The seat made in rotomolding technology of LDPE. It is adapted to the needs of the disable. A durable and modern structure ensures comfort and safety. A buckle provided prevents a fall.

Sedute sicure ed INCLUSIVE
Safety and INCLUSIVE seats

Realizzata in LDPE e disponibile in molte varietà di colori
Made of LDPE and suitable with many colour varieties available



50005-sa - Seduta Tandem_Tandem Seat



Materiali

Plastica LDPE colorato, imbottitura in EPDM a lato

Materials

Dyed LDPE plastic, impact-cushioning EPDM rubber on the sides.

Misure

Lunghezza 1260 mm

Larghezza 540 mm

Altezza 480 mm

Standard di sicurezza EN-1176-2

Technical

Length 1260 mm

Width 540 mm

Height 480 mm

Safety standard EN-1176-2

Caratteristiche

La seduta è realizzata con la tecnologia rotostampata del LDPE. È adatta per il genitore e il bambino. La moderna e resistente struttura garantiscono confort e sicurezza.

Characteristic seat

The seat made in rotomolding technology of LDPE. It is adapted for a parent with a child. A durable and modern structure ensures comfort and safety.

Realizzata in LDPE e disponibile in molte varietà di colori
Made of LDPE and suitable with many colour varieties available

**Sedute sicure
ed INCLUSIVE**

Safety and
INCLUSIVE
seats



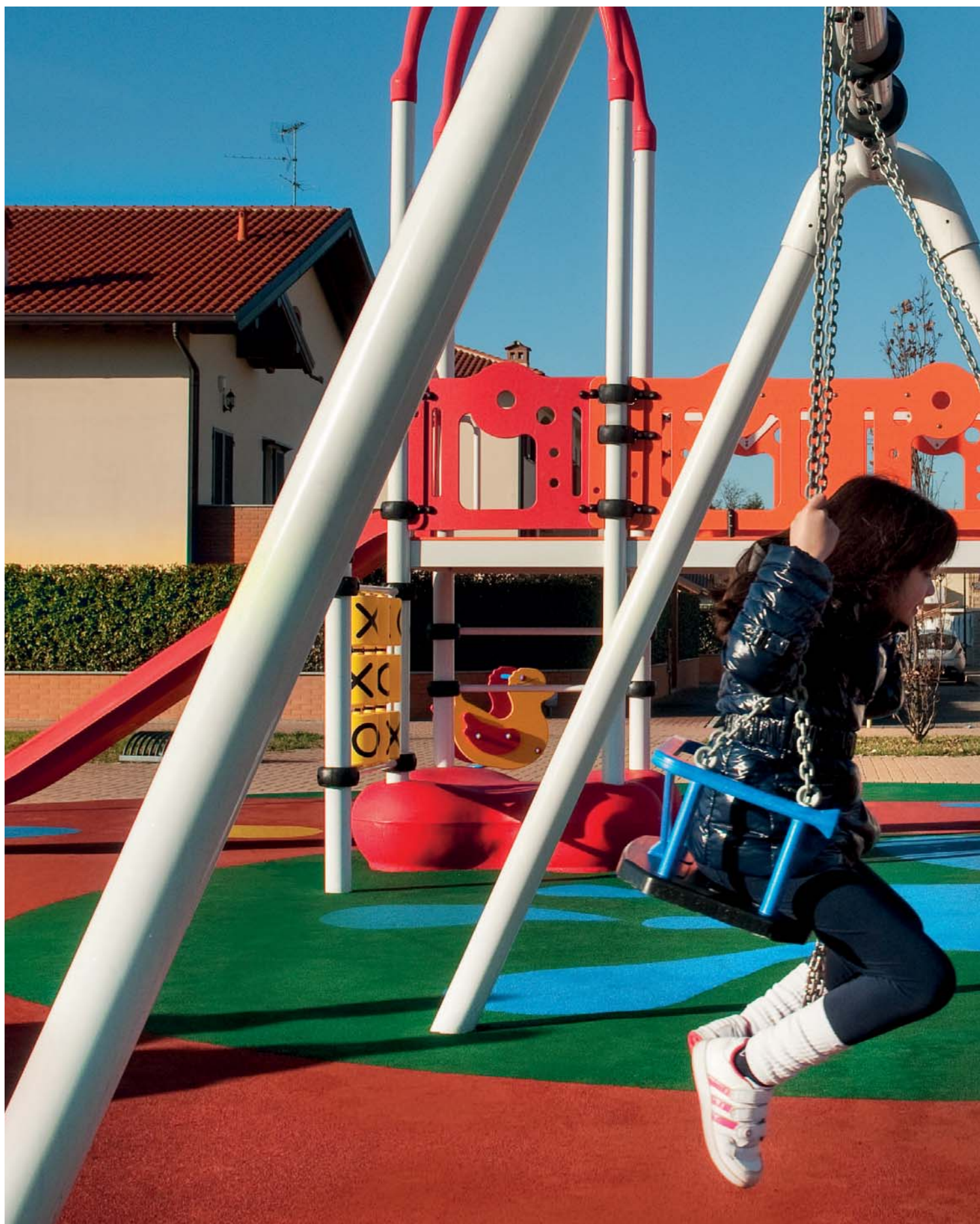

Attrezzature per parchi giochi:
combinazione di superficie antishock
per i parchi pubblici del Comune di
Firenze

Italy playground equipment and
antishock surface combination for
the public parks of the municipality of
Florence



**Struttura metallica
a grande sezione,
diametro mm 102**

Metal structure
with a large section
diameter 102 mm

 [web link](#)







FPA 0001

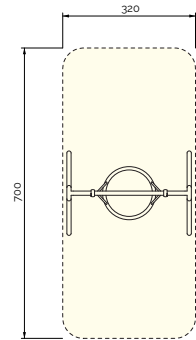
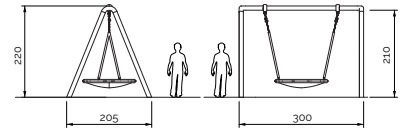

FPA 0002

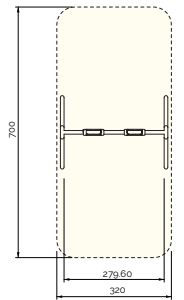
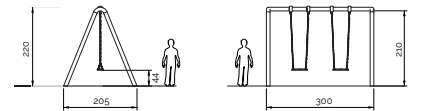

FPA 0003

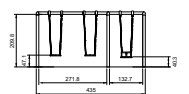
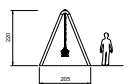
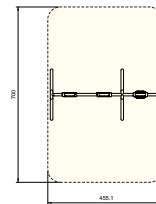

FPA 0004

3+
anni

124
cm

220
cm

414
m²

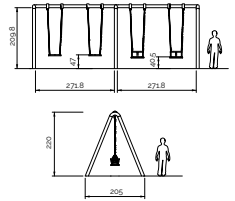
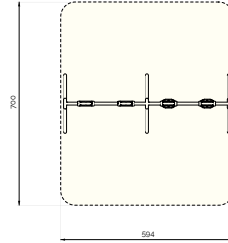

3+
anni

121
cm

220
cm

31,6
m²

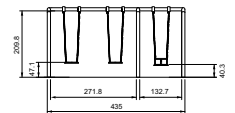
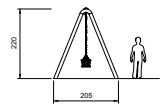
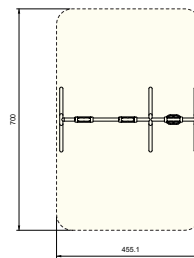

FPA 0005

3+
anni

124
cm

220
cm

22,2
m²

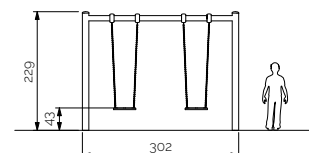
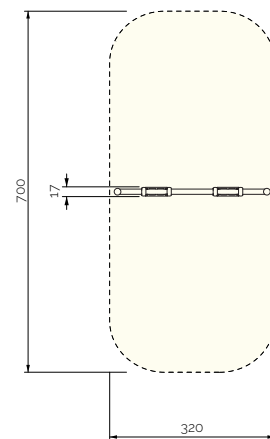

FPA EXPO 0019



8530

2070

3380

3050

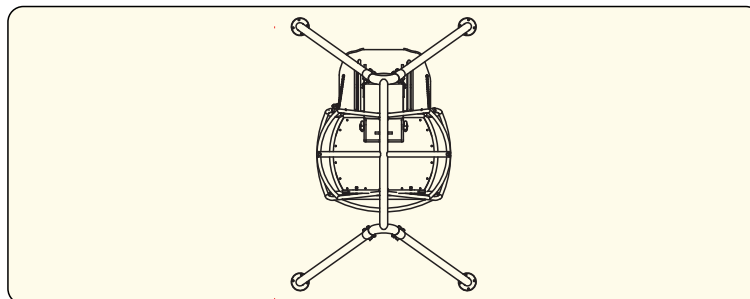

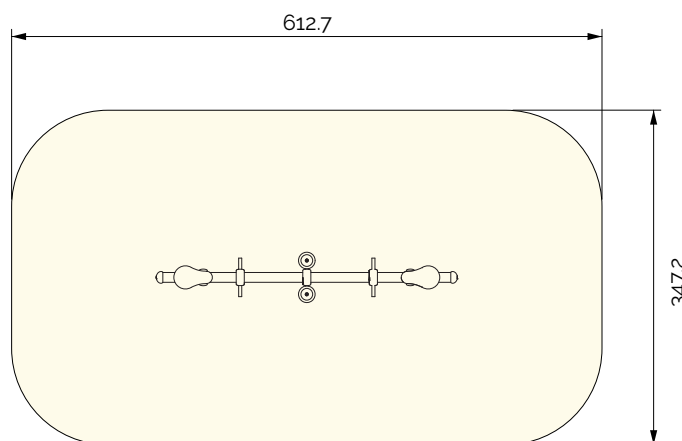
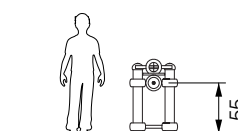
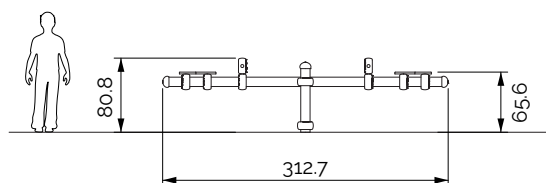

LINEA SMART

Modellata con forme e colori moderni che la rendono adatta al contesto urbano. L'ampia gamma di colori disponibili, le permette di essere inserita in ogni ambientazione

SMART LINE

Designed with modern colours and shapes that make it suitable for urban context. The wide range of colours allows it to be included in every location





3+
anni

150
cm

355
cm

34
m²



FPT 1007

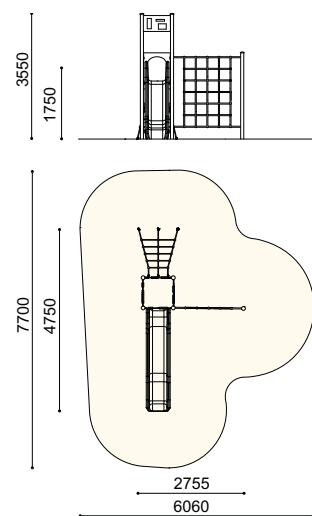

3+
anni

150
cm

355
cm

47.5
m²



FPT 1008

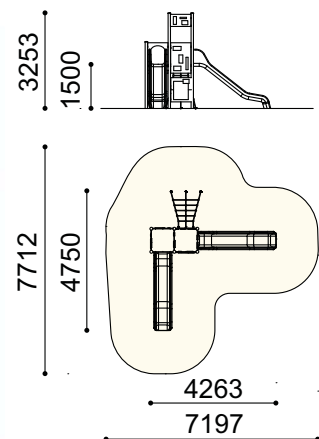

3+
anni

150
cm

355
cm

35
m²



FPT 1009

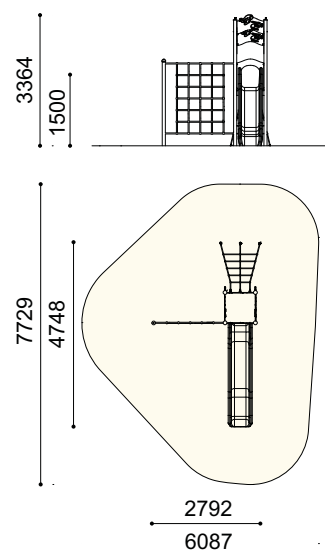

FPT 2011

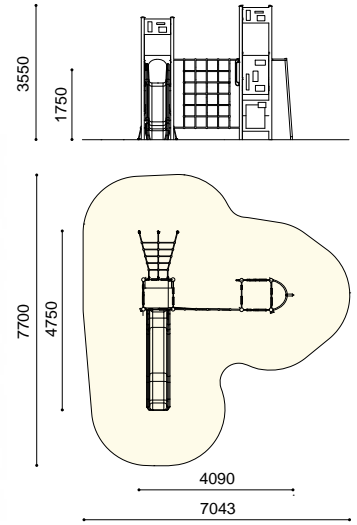

FPT 2012

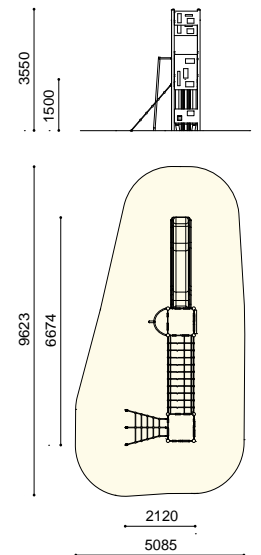

FPT 2013

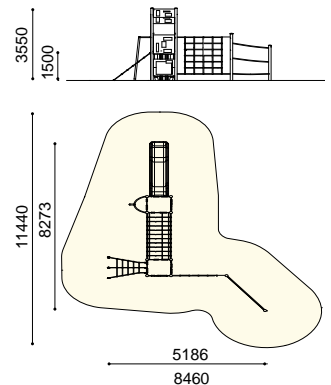



FPT 2014

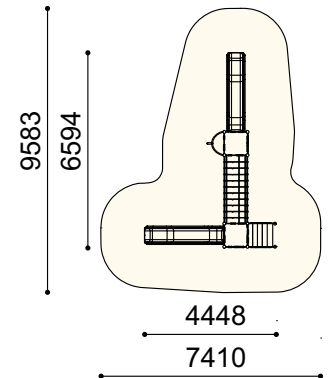
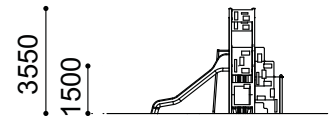

FPT 2015

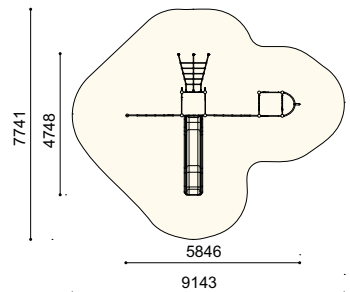
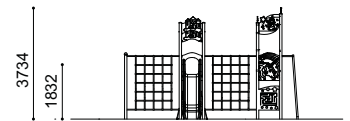

FPT 2016

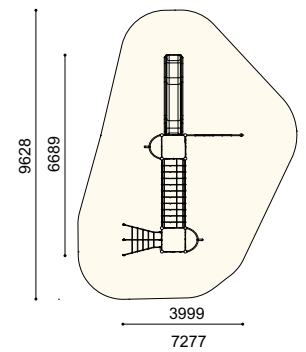
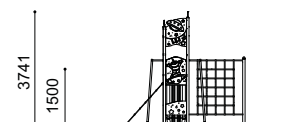

FPT 3010

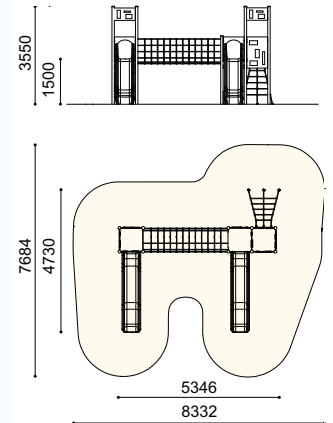
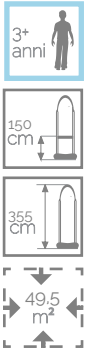

FPT 3011

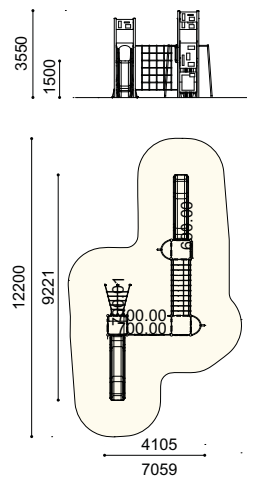
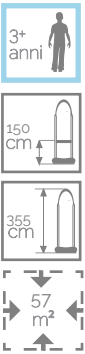

FPT 3012

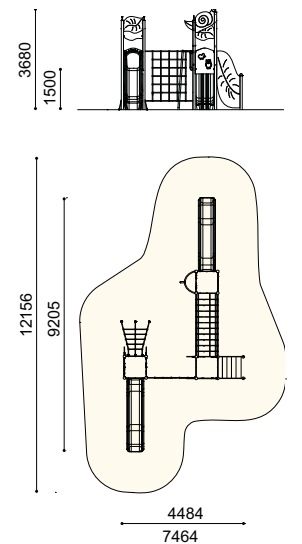

Strutture dal design moderno studiate per adattarsi alle esigenze dei contesti urbani con strutture semplici e funzionali. Un robusto telaio da 102 mm rivestito con sistema di verniciatura Triplex garantiscono un'eccezionale durabilità.

Structures with modern design studied to adapt to the needs of urban contexts with simple and functional structures. A strong tubular frame 102 mm thickness and film-coated Triplex System guarantee an excellent durability



[web link](#)







FPT 1001

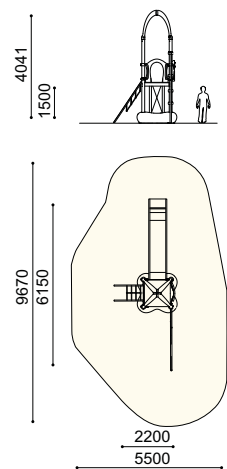

FPT 1002

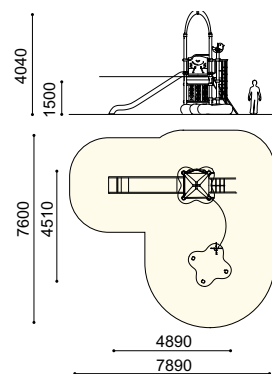

FPT 1003

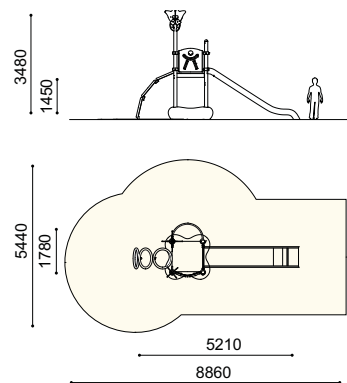

FPT 1004

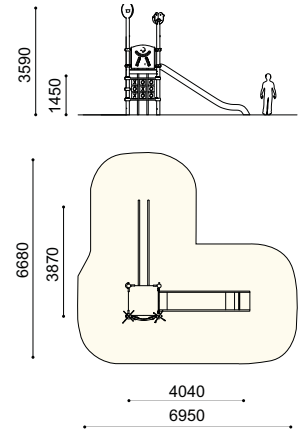
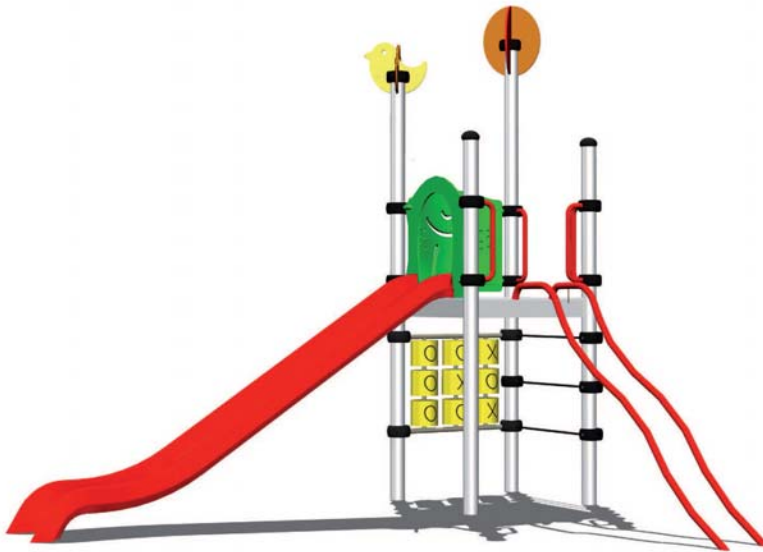
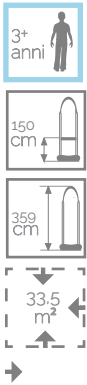

FPT 2001

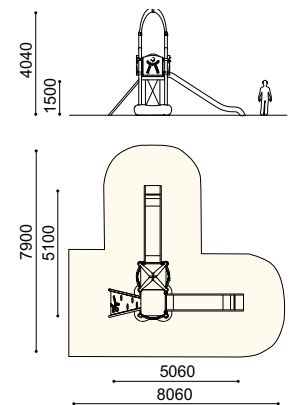
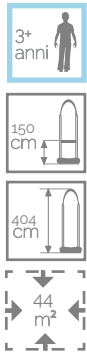

FPT 2002

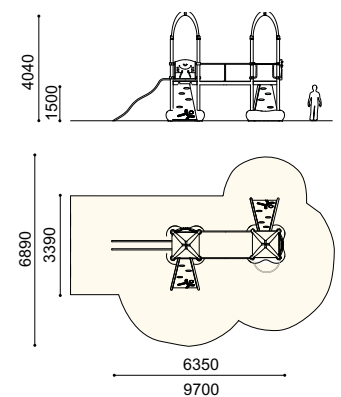
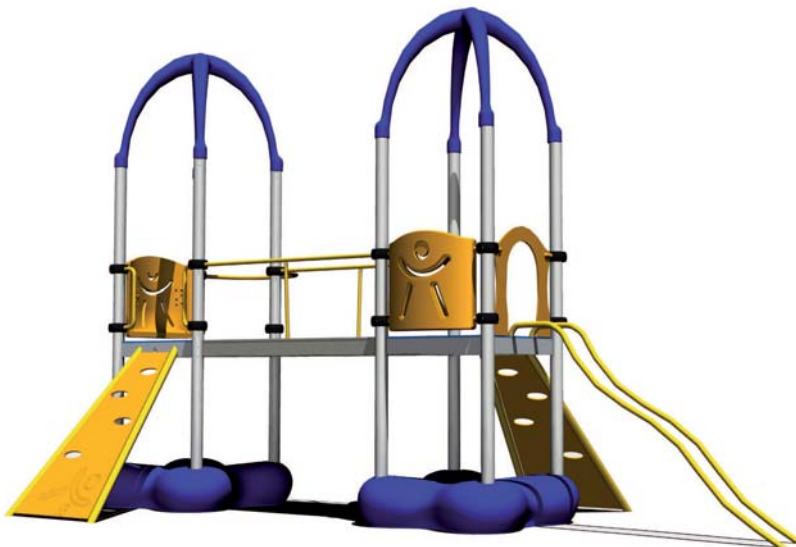
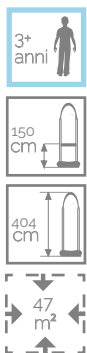

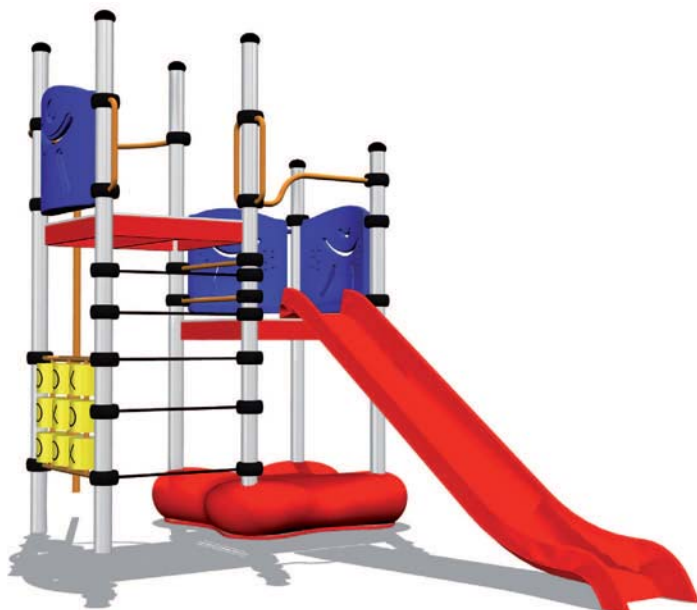

FPT 2003

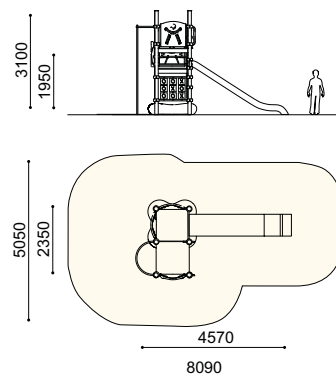

FPT 2004

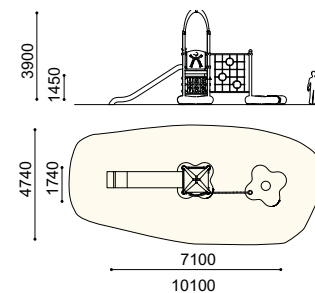

FPT 2005

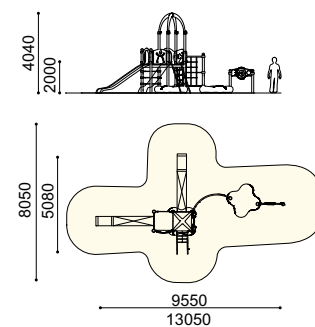

FPT 2006

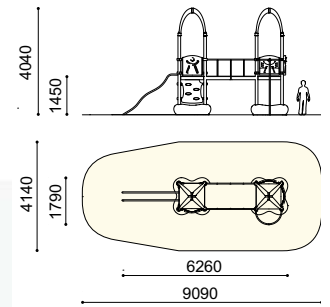
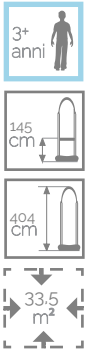

FPT 3002

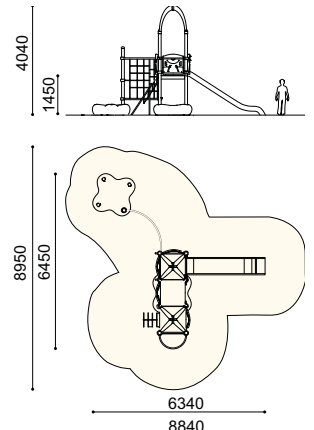
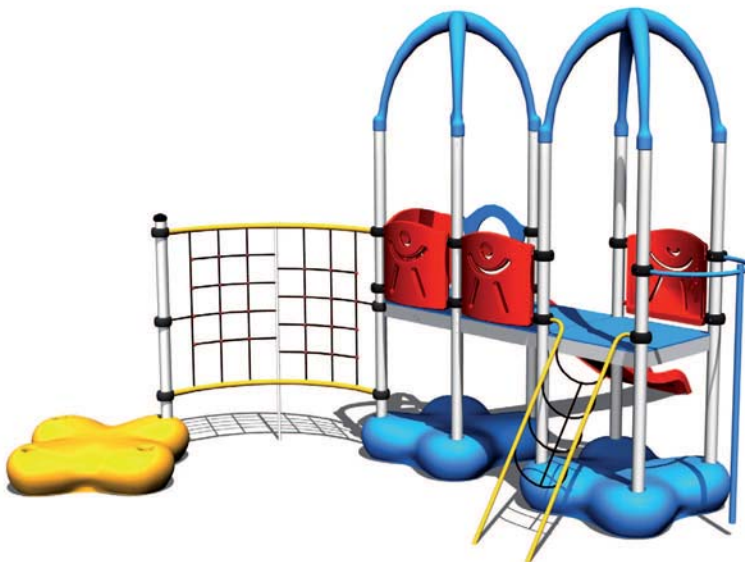
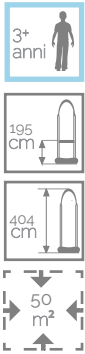

FPT 3003

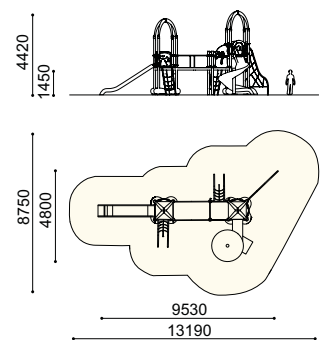
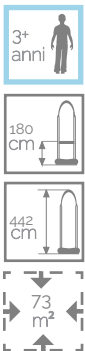

3+
anni

145
cm

390
cm

43
m²

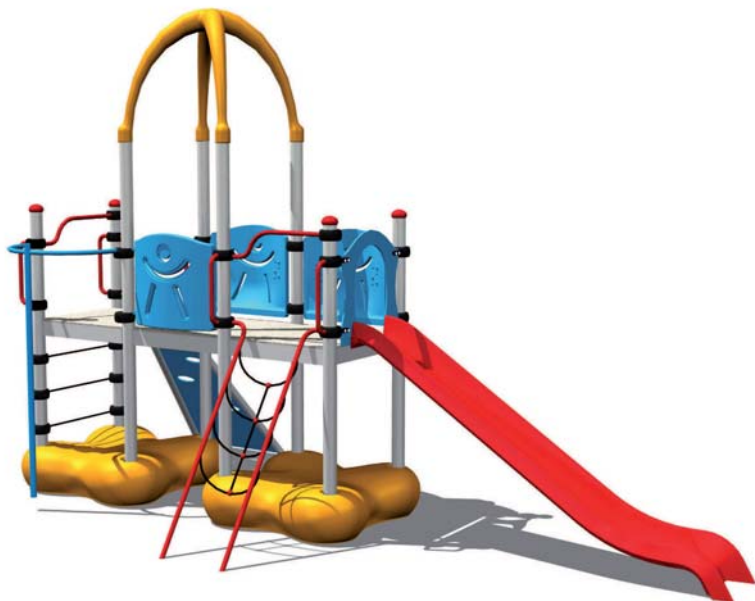

FPT 3001

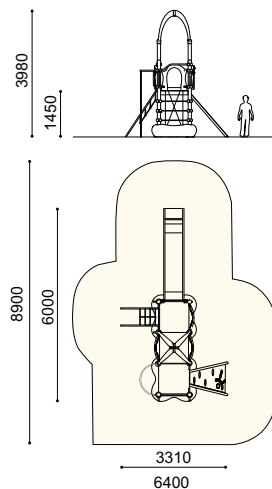

3+
anni

145
cm

404
cm

70
m²

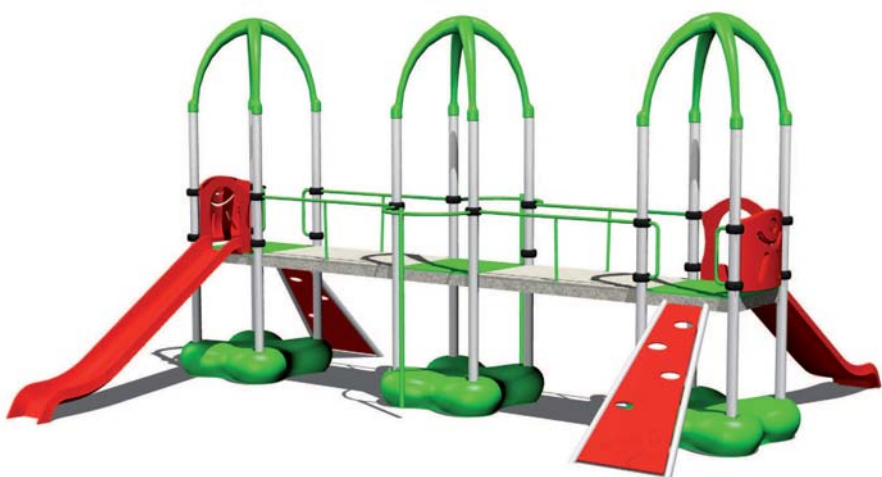

FPT 3004

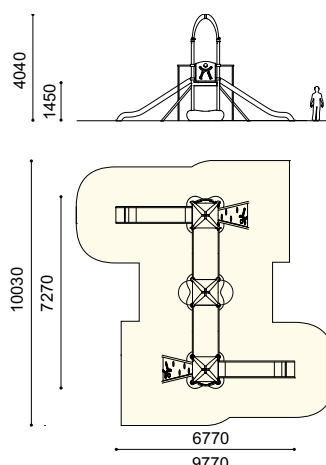

3+
anni

145
cm

404
cm

57
m²



FPT 3005

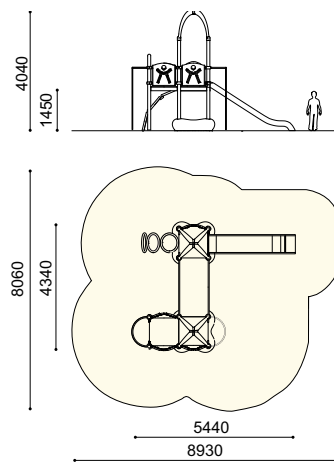

FPT 3006

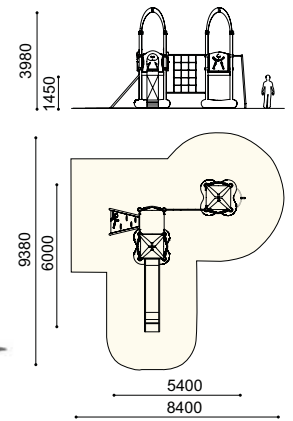
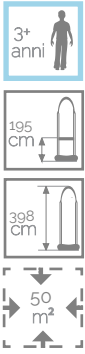

FPT 3007

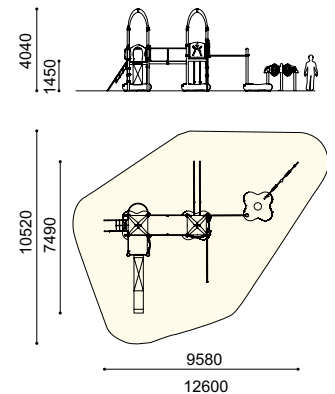
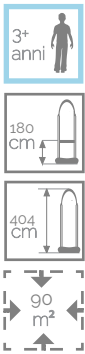

FPT 4001

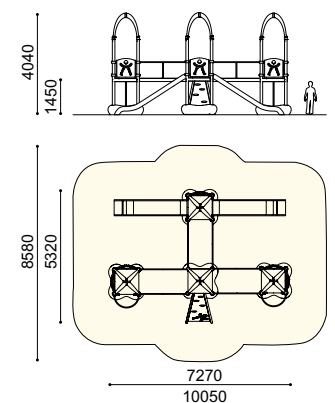
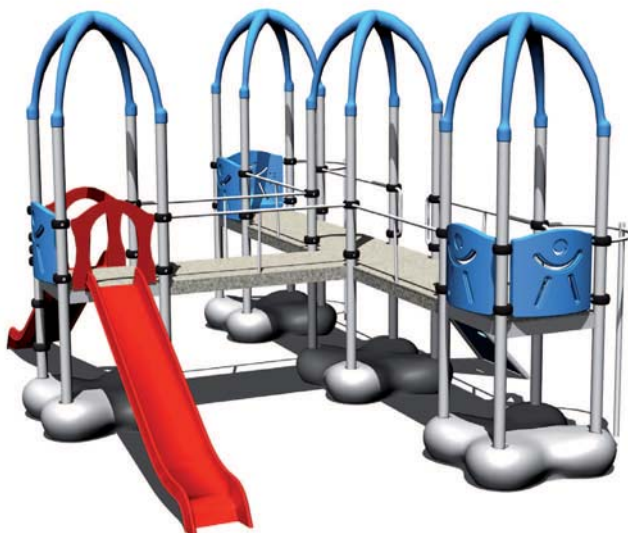
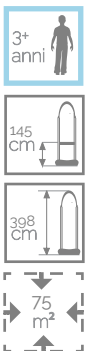

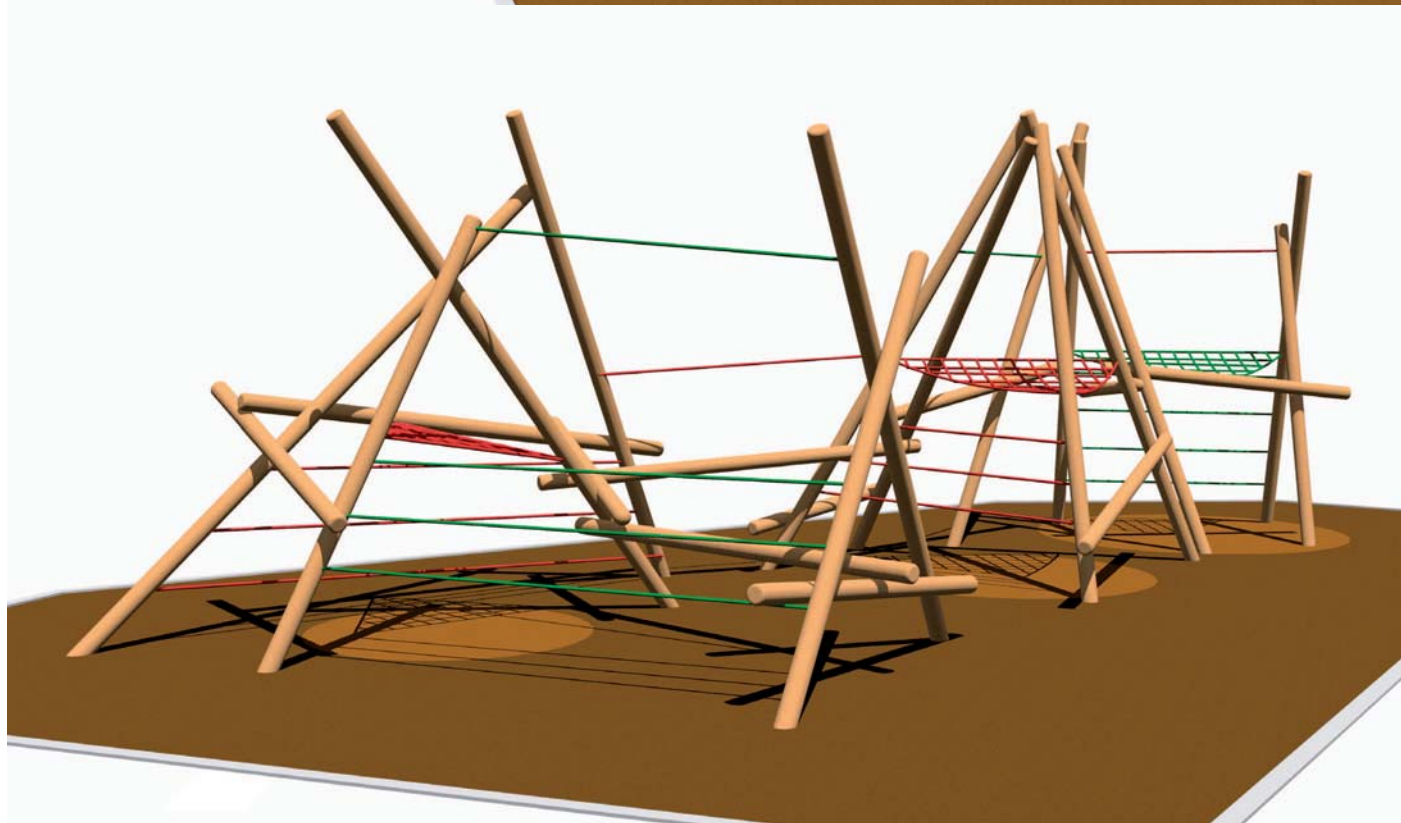
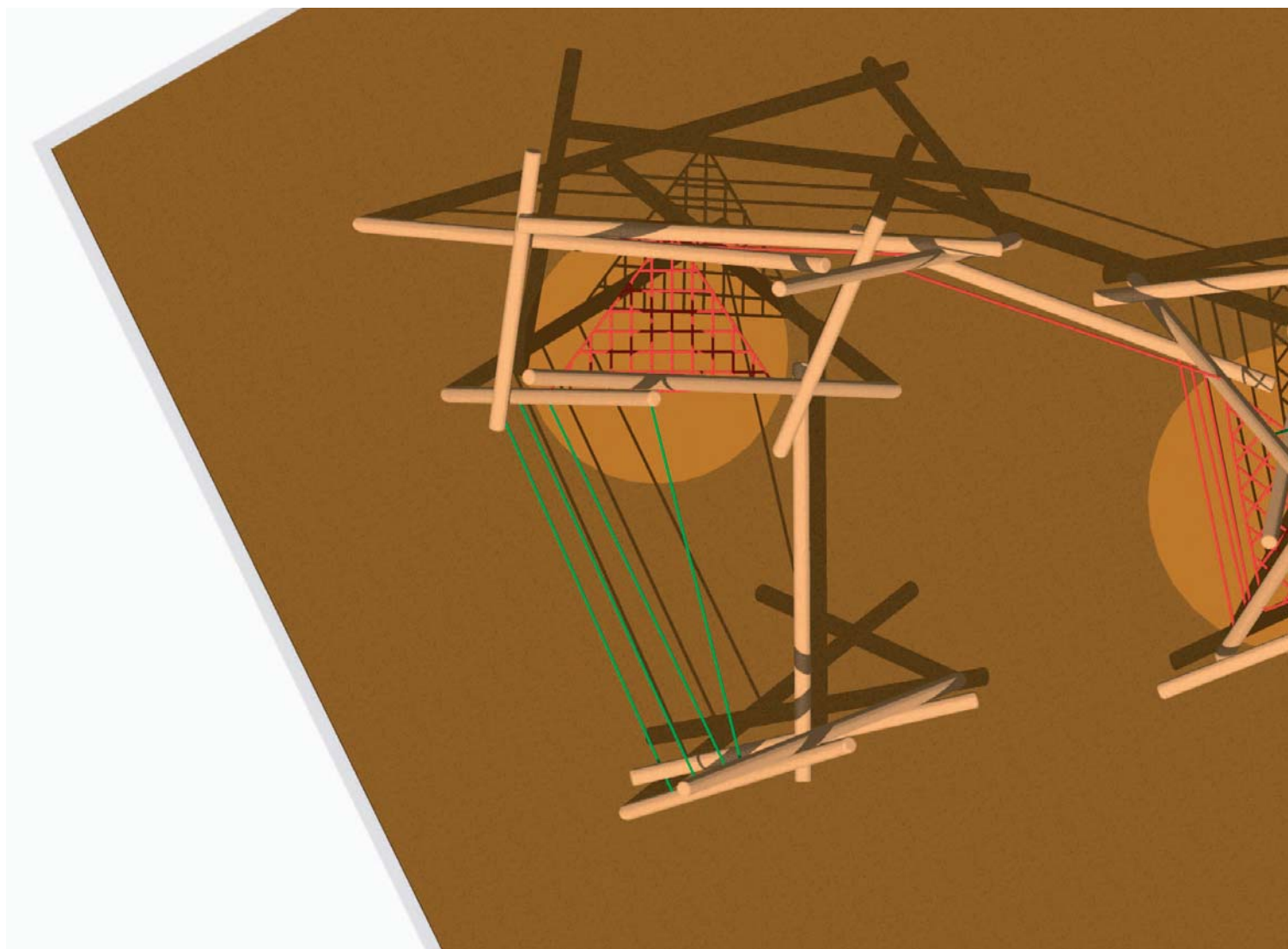

Strutture gioco che utilizzano robusti pali in robinia per la realizzazione di un parco naturale.

Play structures using sturdy poles in robinia for the realization a natural park.

[web link](#)

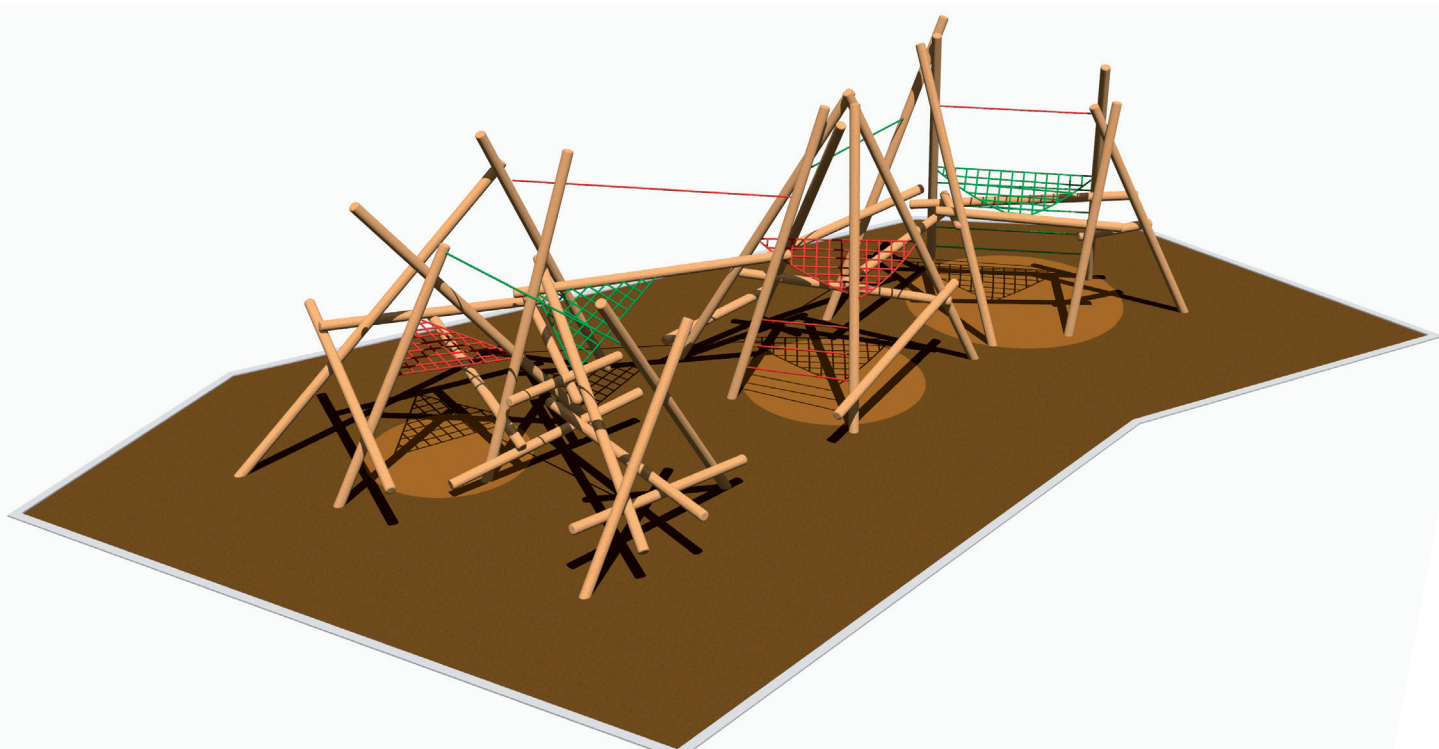
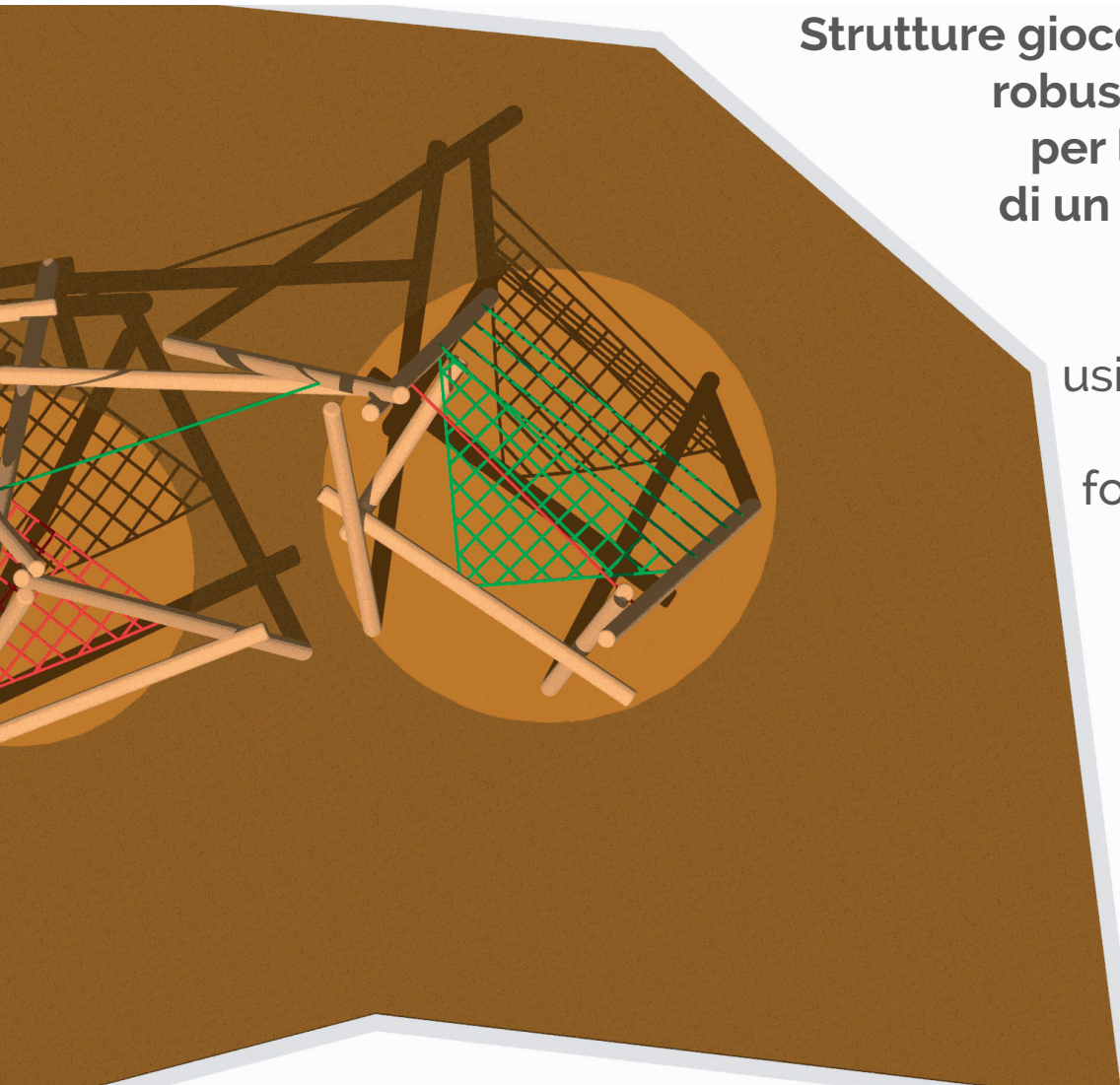

Linea Forest, vicini alla natura



FPT 2009

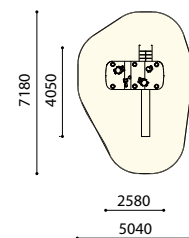

FPT 2017

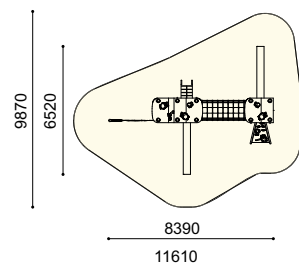

FPT 2018

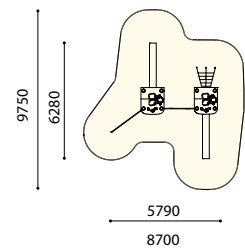
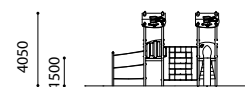

FPT 2010

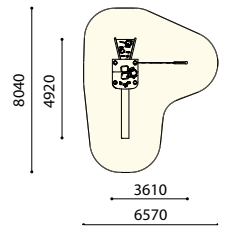
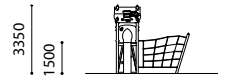

FPT 3009

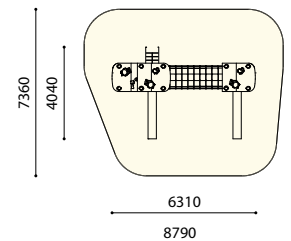
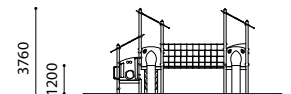
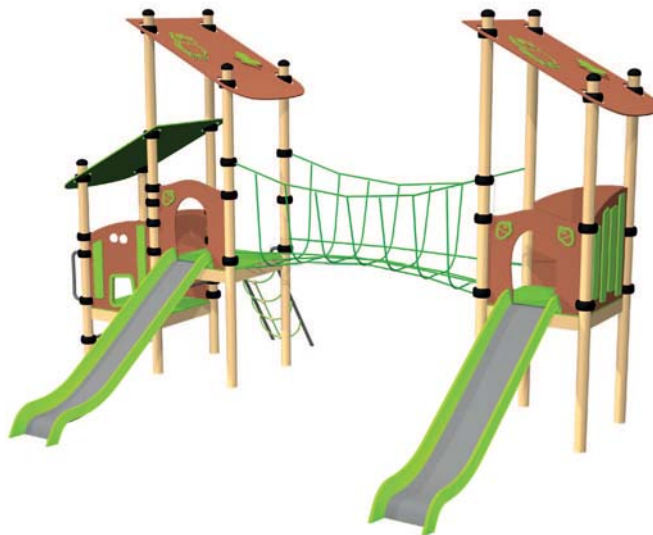

FPT 3013

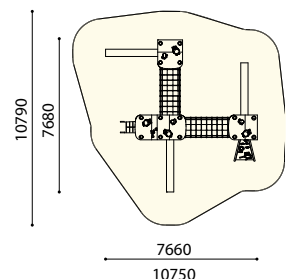





fun
PLAY
stella 

stella 

STRUTTURE PER IL MOVIMENTO

FunPlay Stella è leggera e dinamica,
per un gioco estremamente attivo,
libero e stimolante.

Linee accattivanti che fanno di ogni
attrezzatura una scultura!

STRUCTURES FOR MOVING

Funplay Stella is light and dynamic line
for an active, free and stimulating game.
Engaging lines that changes structure in
sculpture!









Dubai_UAE
Swiss International
Scientific School

Percorso e serie Training Camp

Path and series Training Camp



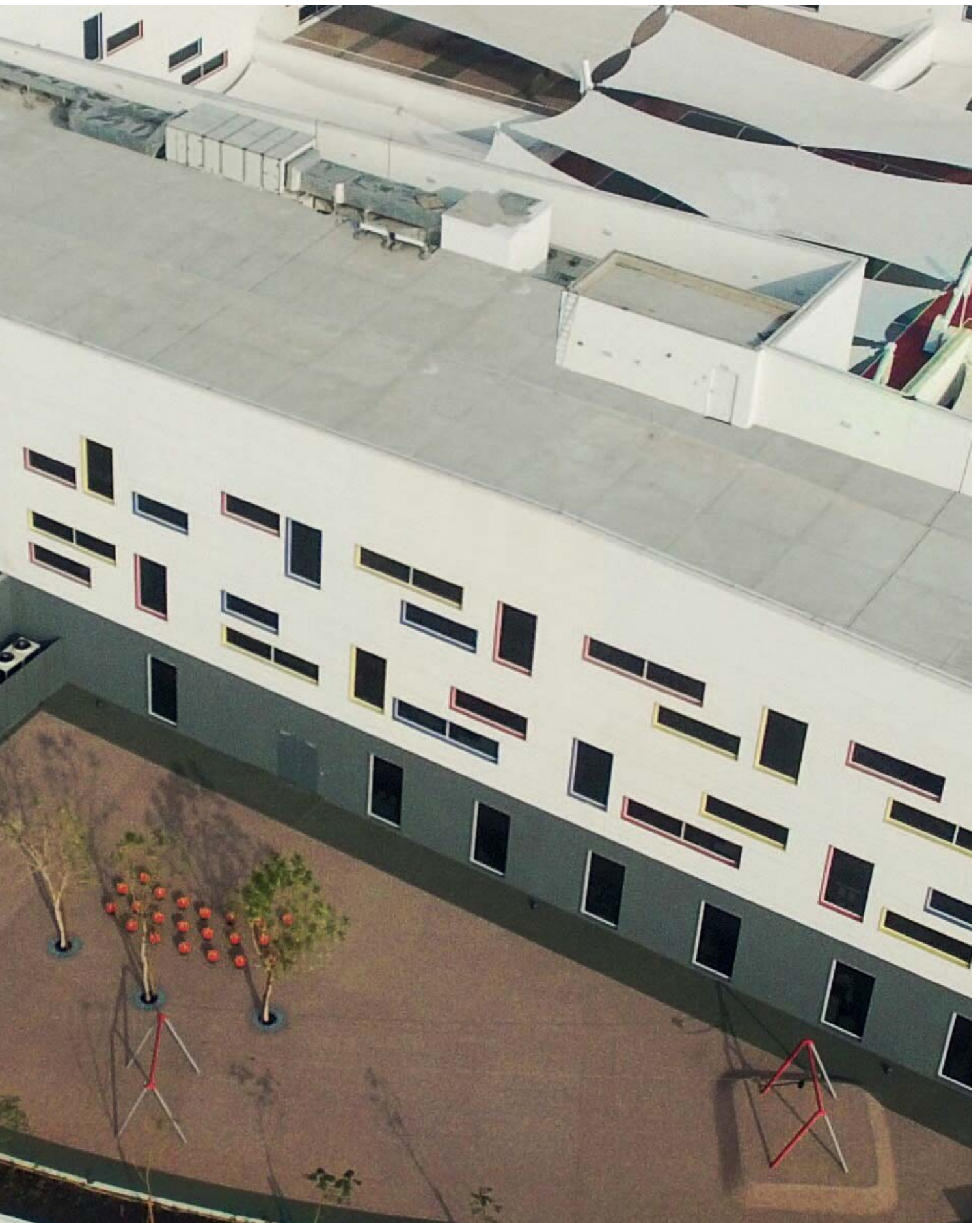













Comune di Brugherio (MI) - Parco giochi comunale

Strutture in polietilene resistente ai raggi UV e con goffratura antigraffio.

Structures polyethylene UV resistant and scratch-resistant embossing.













Strutture composte da percorsi e
Training Camp, sistemi di teleferiche e
funivie, arrampicate e reti

Structures composed by paths and
Training Camps, cableways and teleferic
systems, climbing and networks

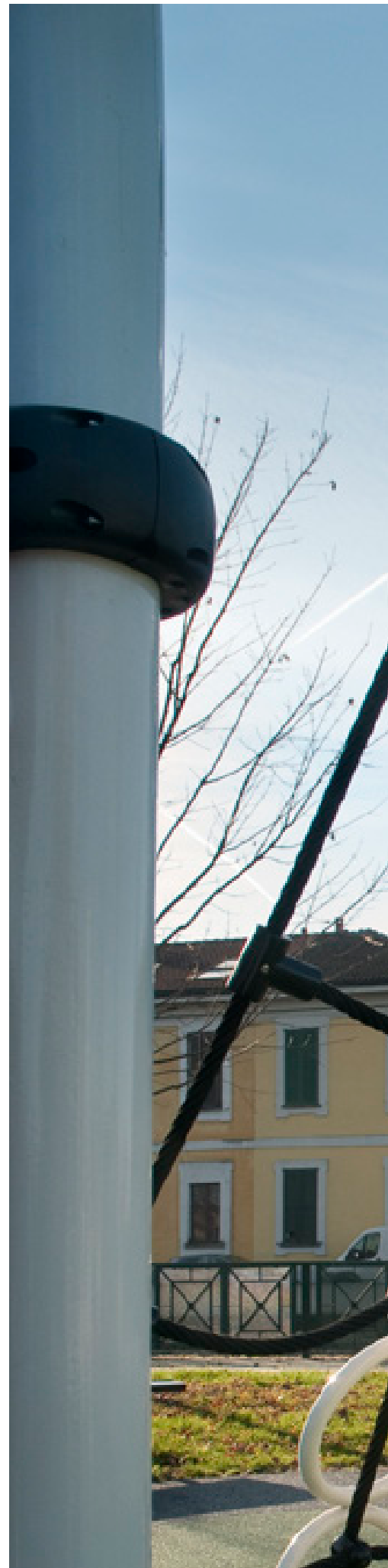



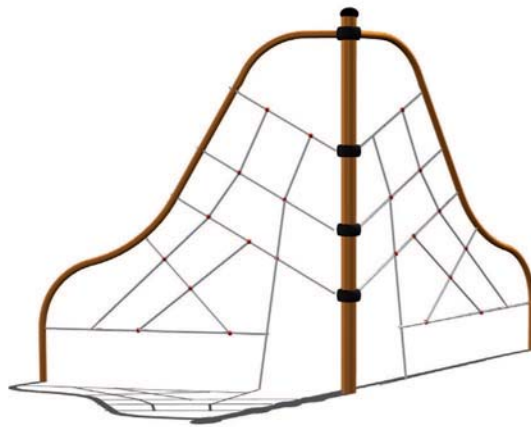
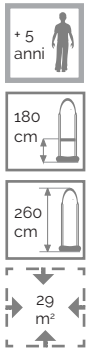

FPS 0001

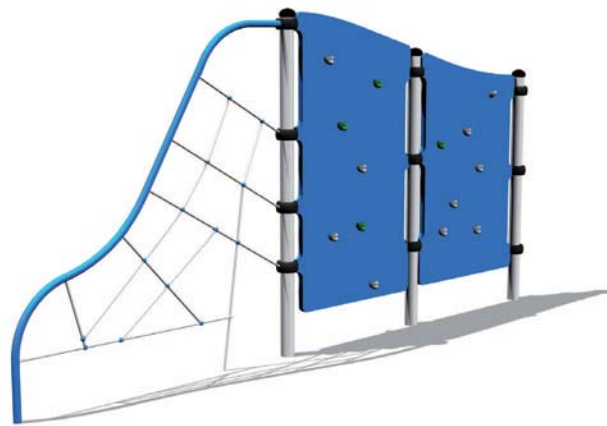
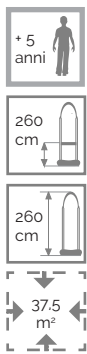
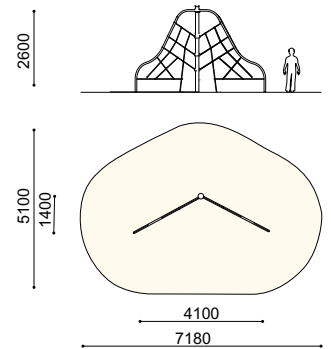

FPS 0002

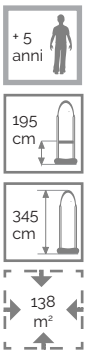
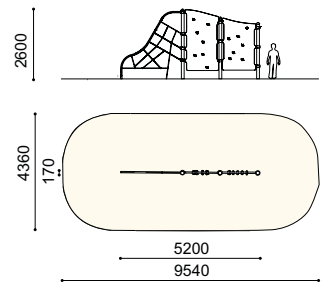

FPS 0003

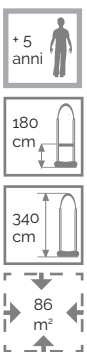
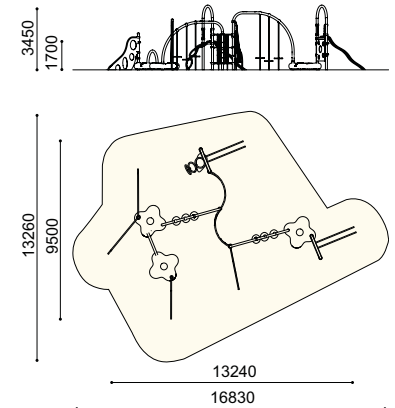

FPS 0004

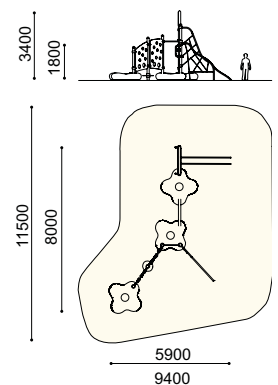

FPS 0005

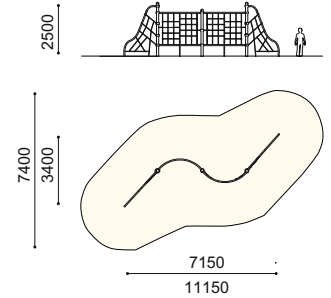
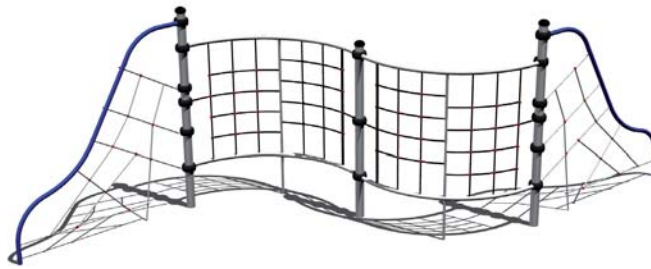
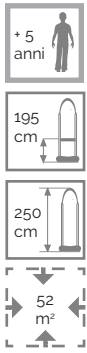

FPS 0006

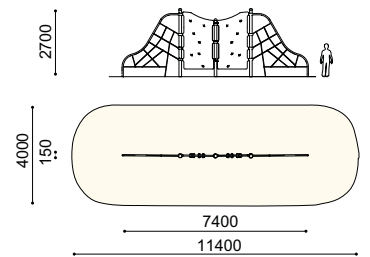
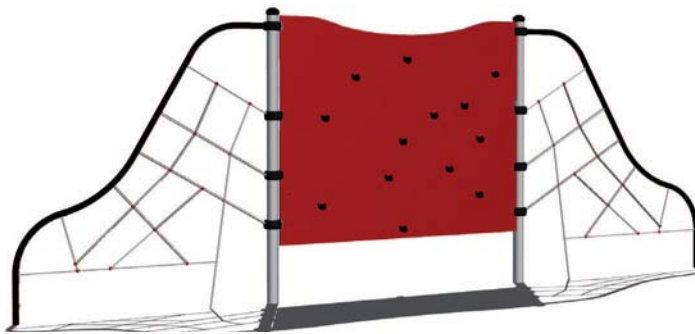
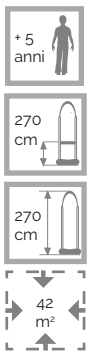

FPS 0007

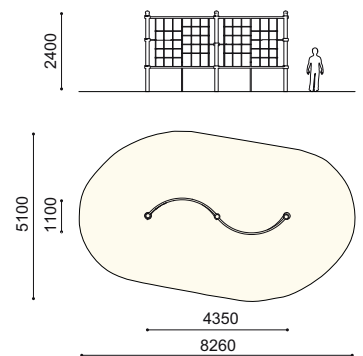
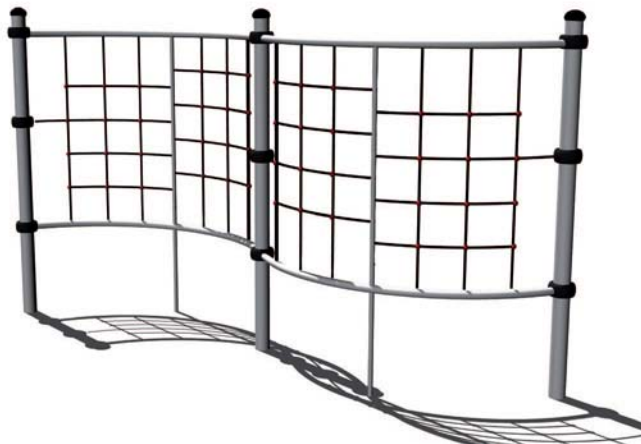
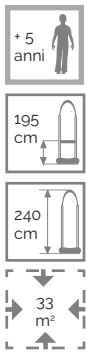

FPS 0008

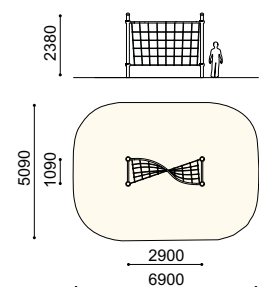
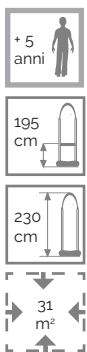

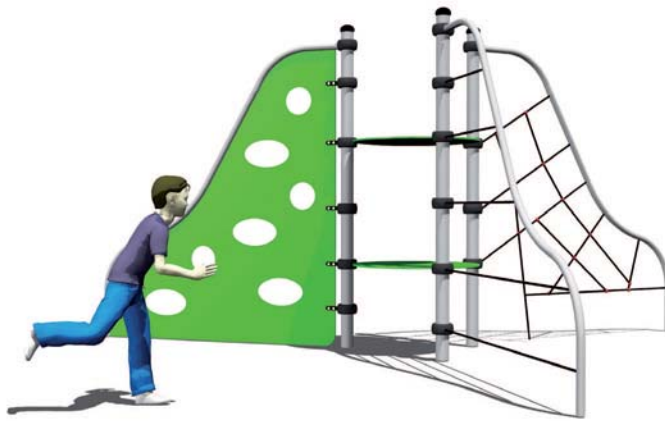
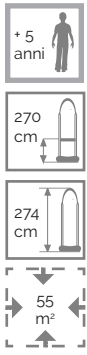

FPS 0009

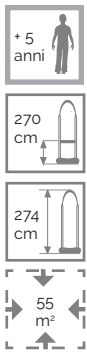
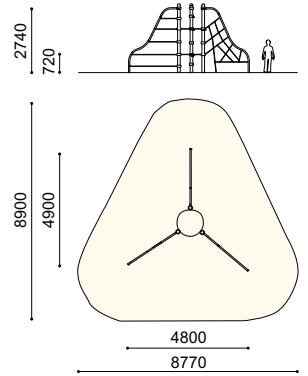

FPS 0010

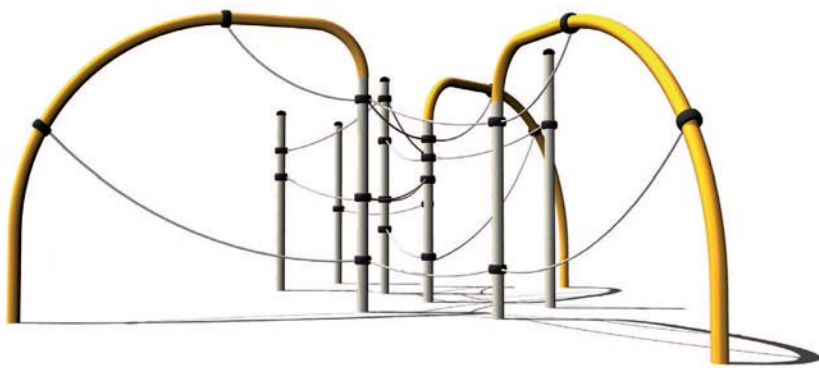
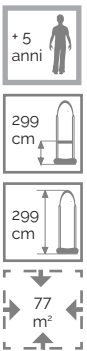
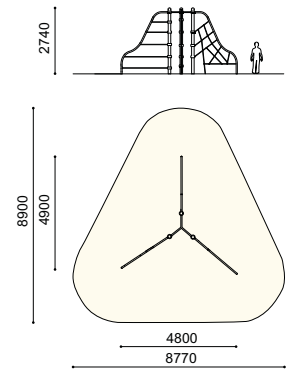

FPS 0011

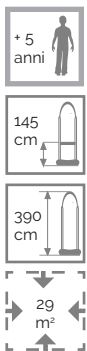
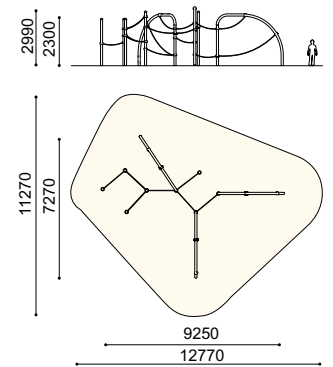

FPS 1001

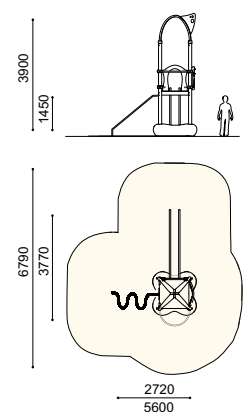

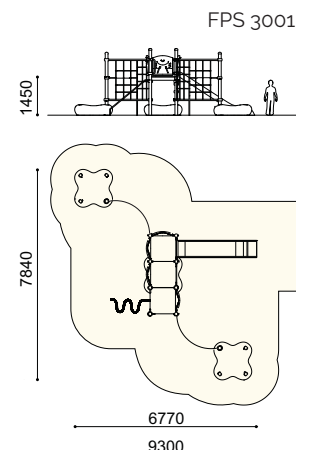
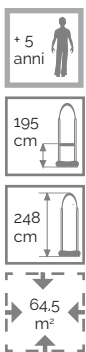
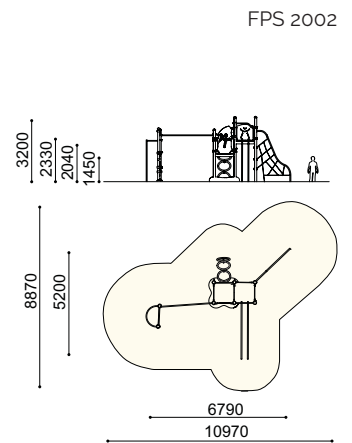
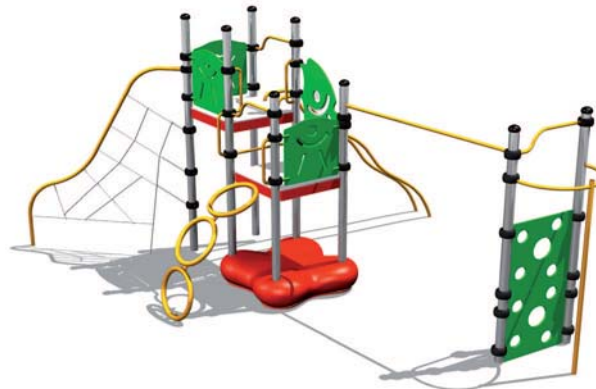
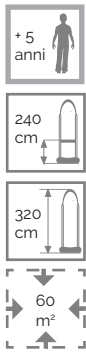
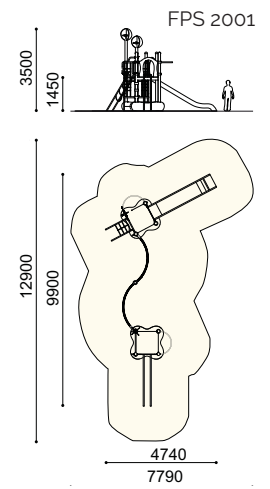
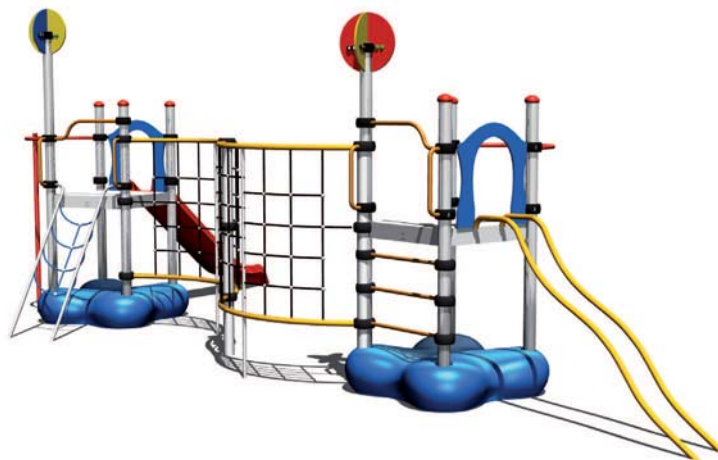
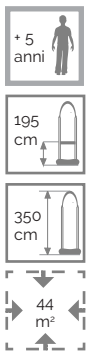
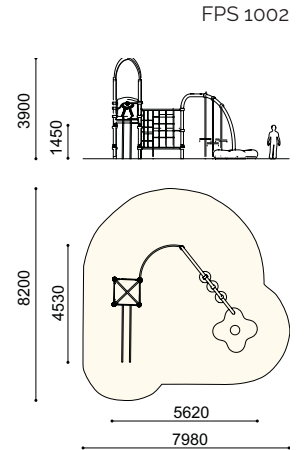
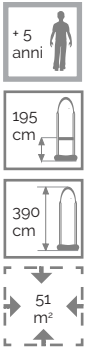

+ 5
anni

195
cm

390
cm

57
m²

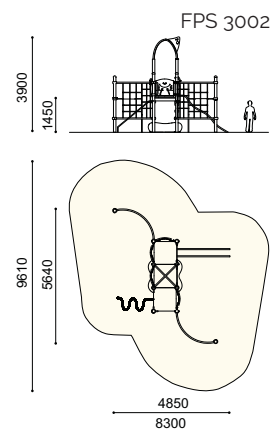

+ 5
anni

195
cm

390
cm

56.5
m²

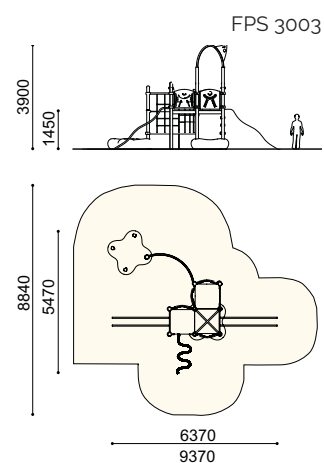
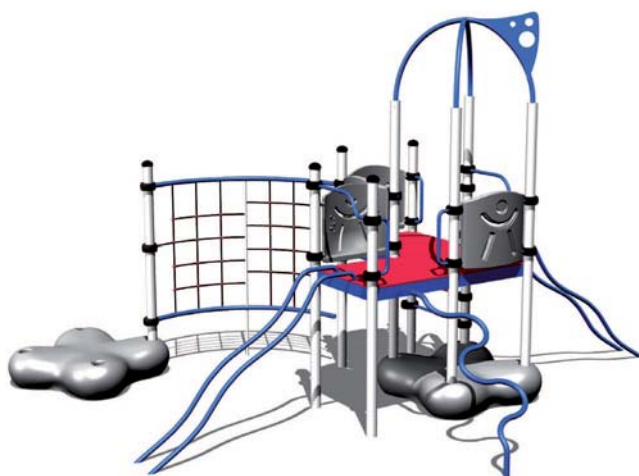

+ 5
anni

180
cm

390
cm

72
m²

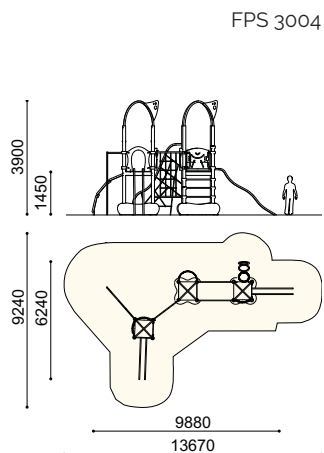

+ 5
anni

195
cm

320
cm

75
m²

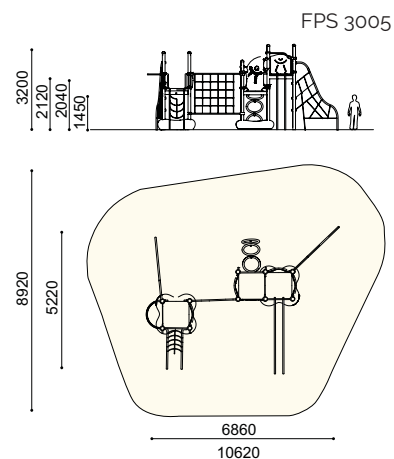
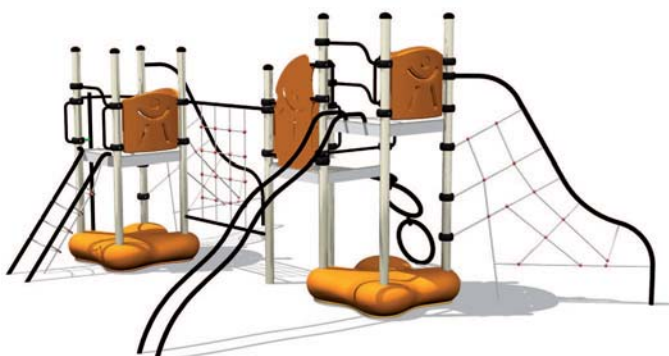

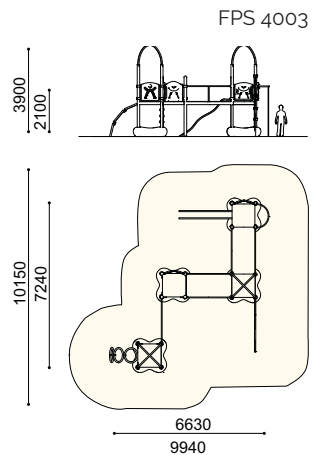
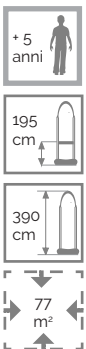
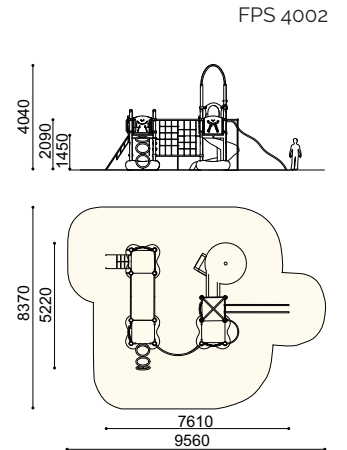
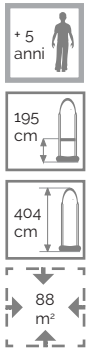
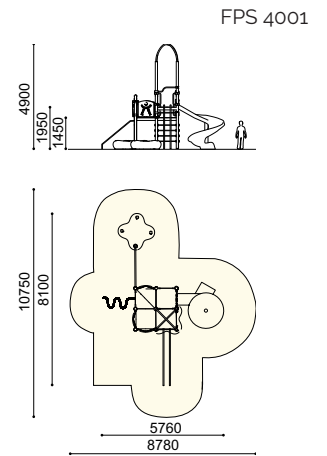
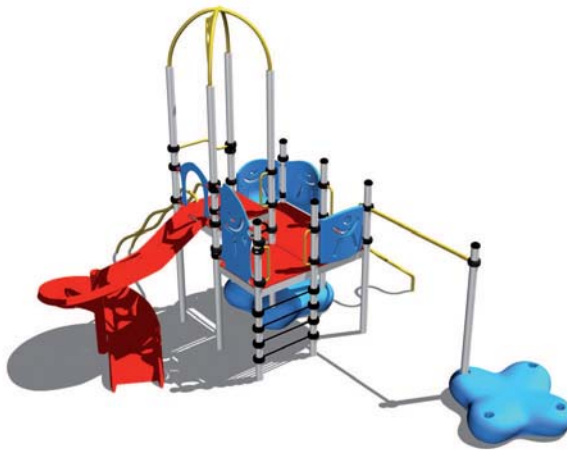
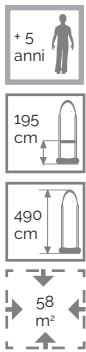
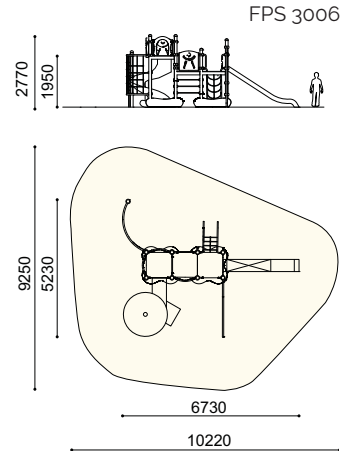
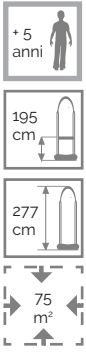

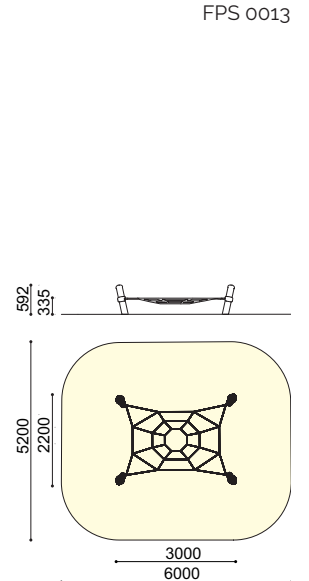
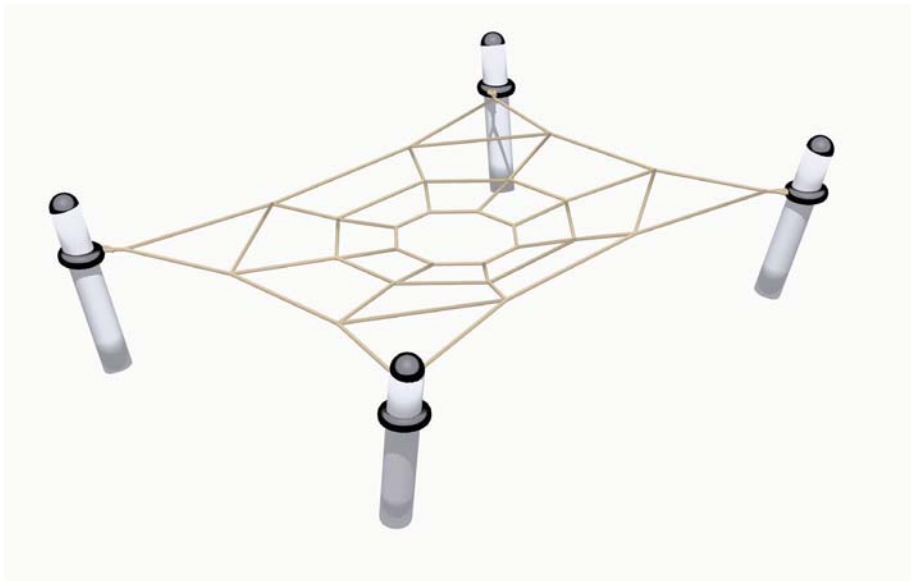
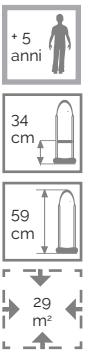
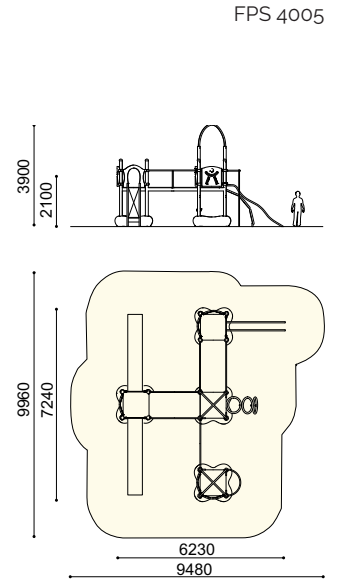
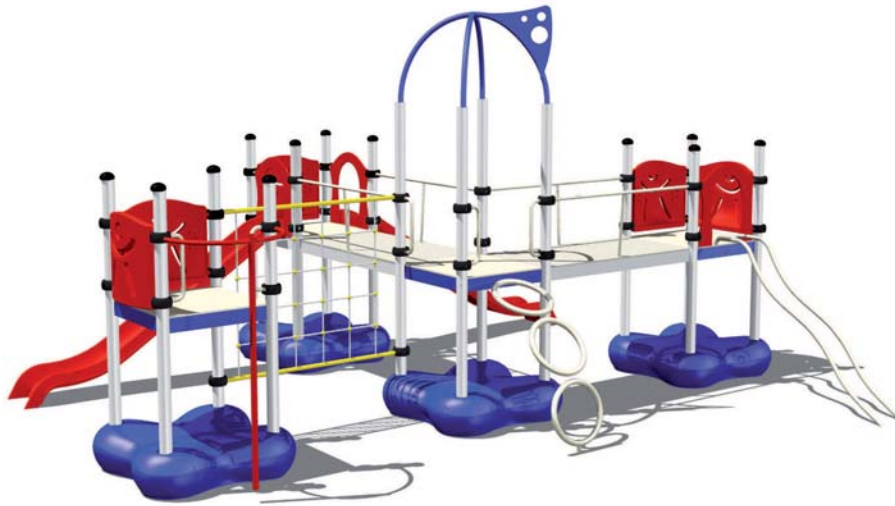
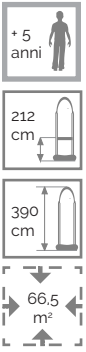
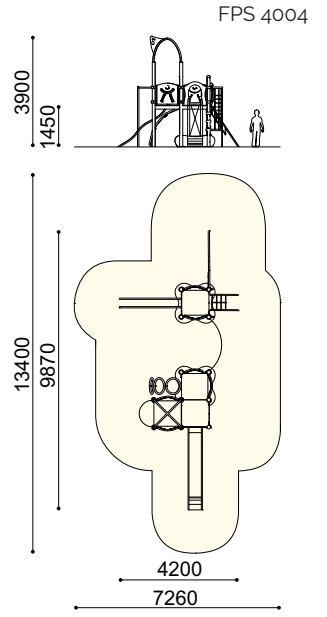
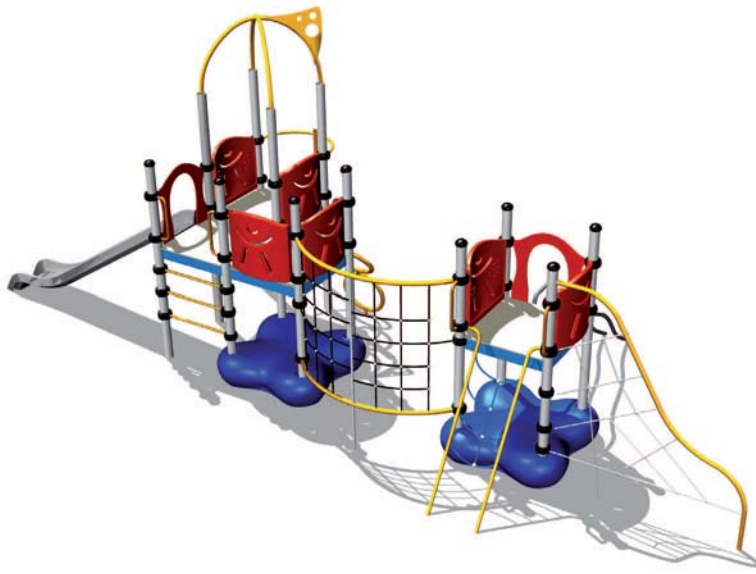
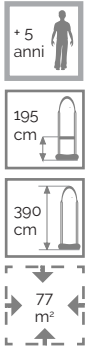

FPS 0014

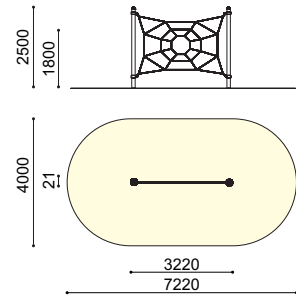
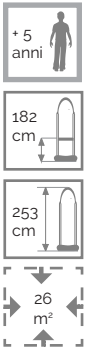

FPS 2003

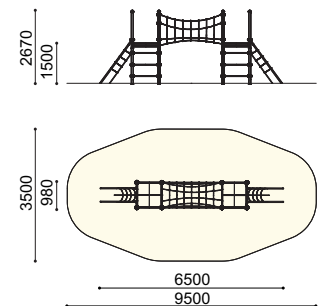
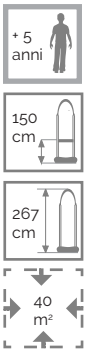

FPS 0015

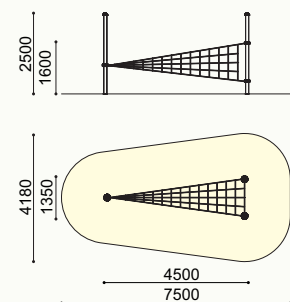
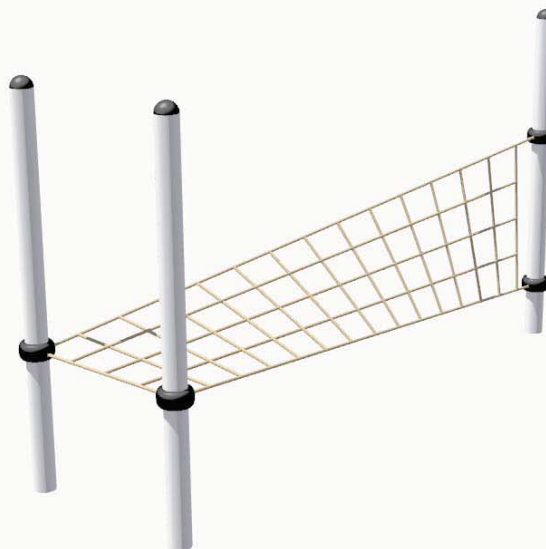
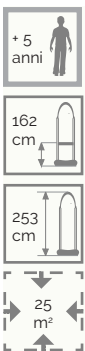

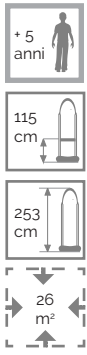

FPS 0016

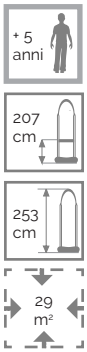
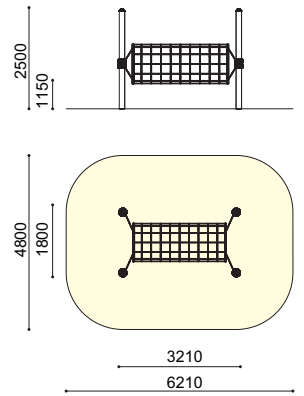

FPS 0017

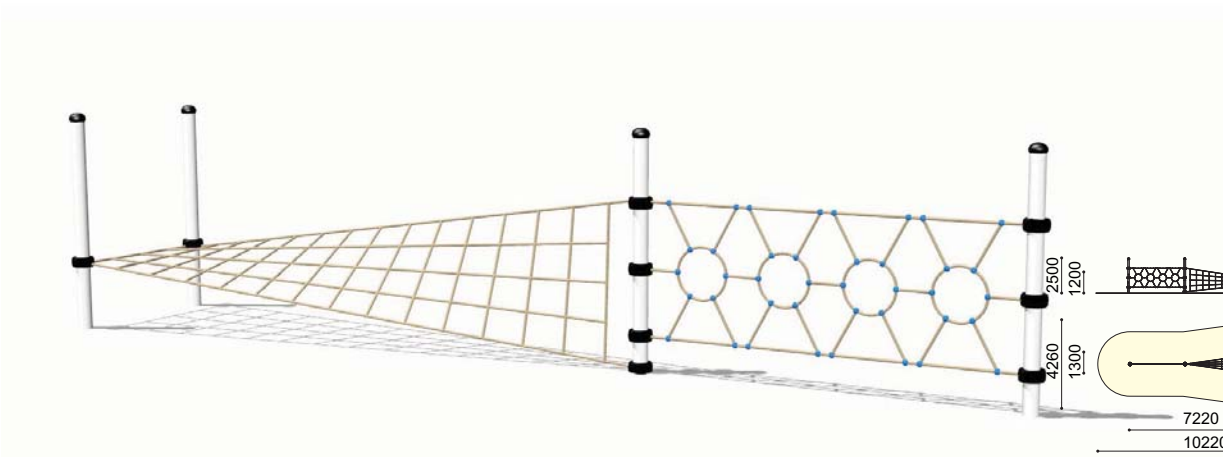
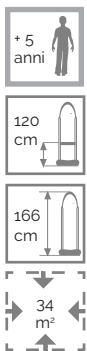
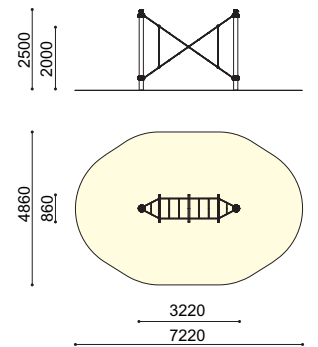

FPS 0018

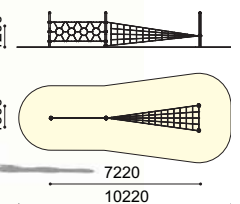

FPS 0020

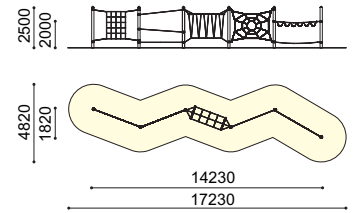
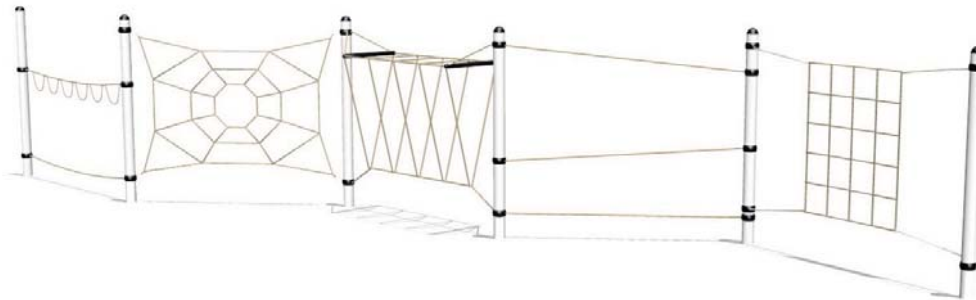
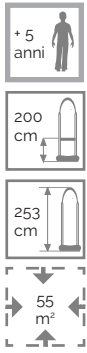

FPS 0019

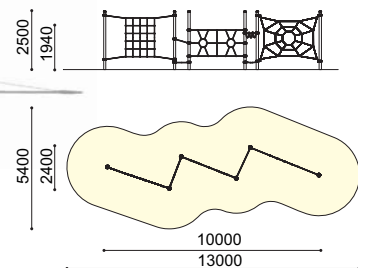
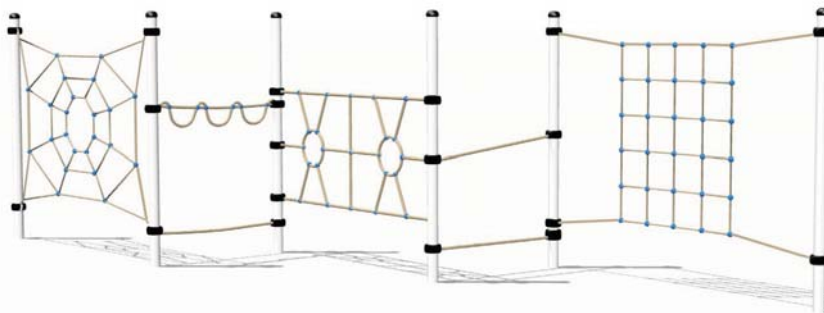
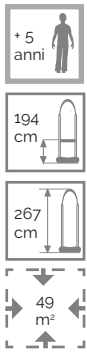

FPS 0021

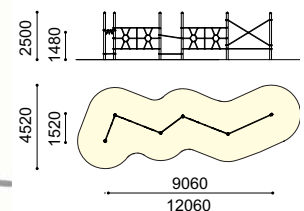
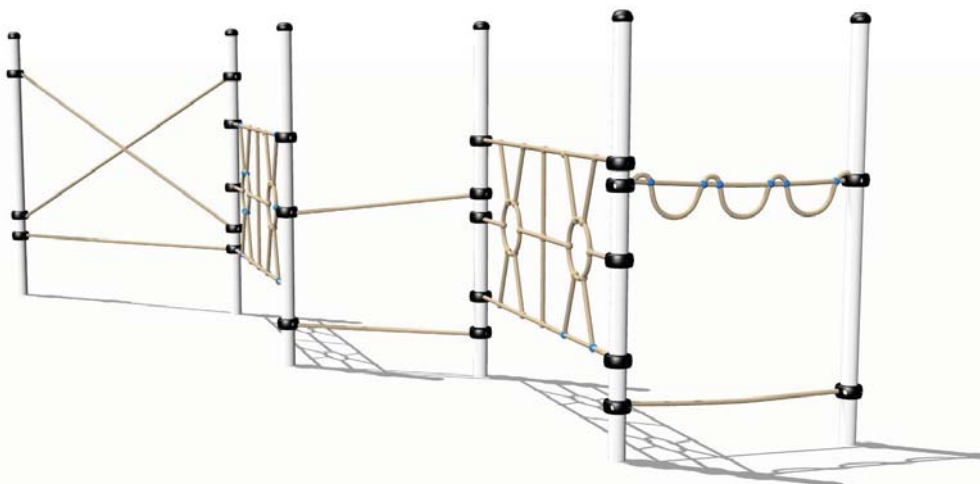
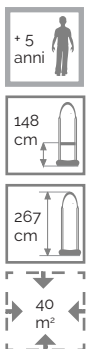



CALORIE CONSUMATE

150 Cal - 45 Minuti

BURN CALORIES

150 Cal - 45 Minutes



Percorsi a rete
adatti ad un gioco di
movimento, divertente
ed utile allo sviluppo
psicomotorio

Climbing net trails suitable for funny
movement games and useful for psycho-motor
development of all kids

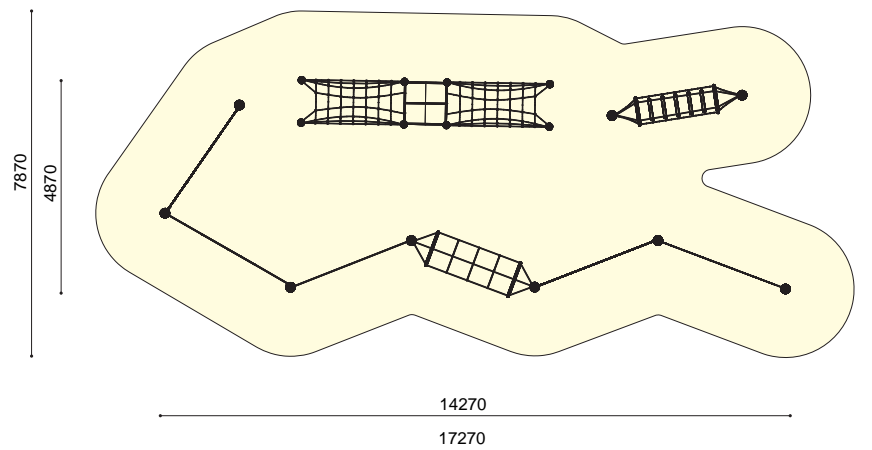
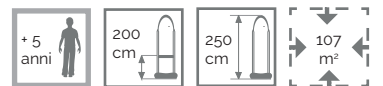
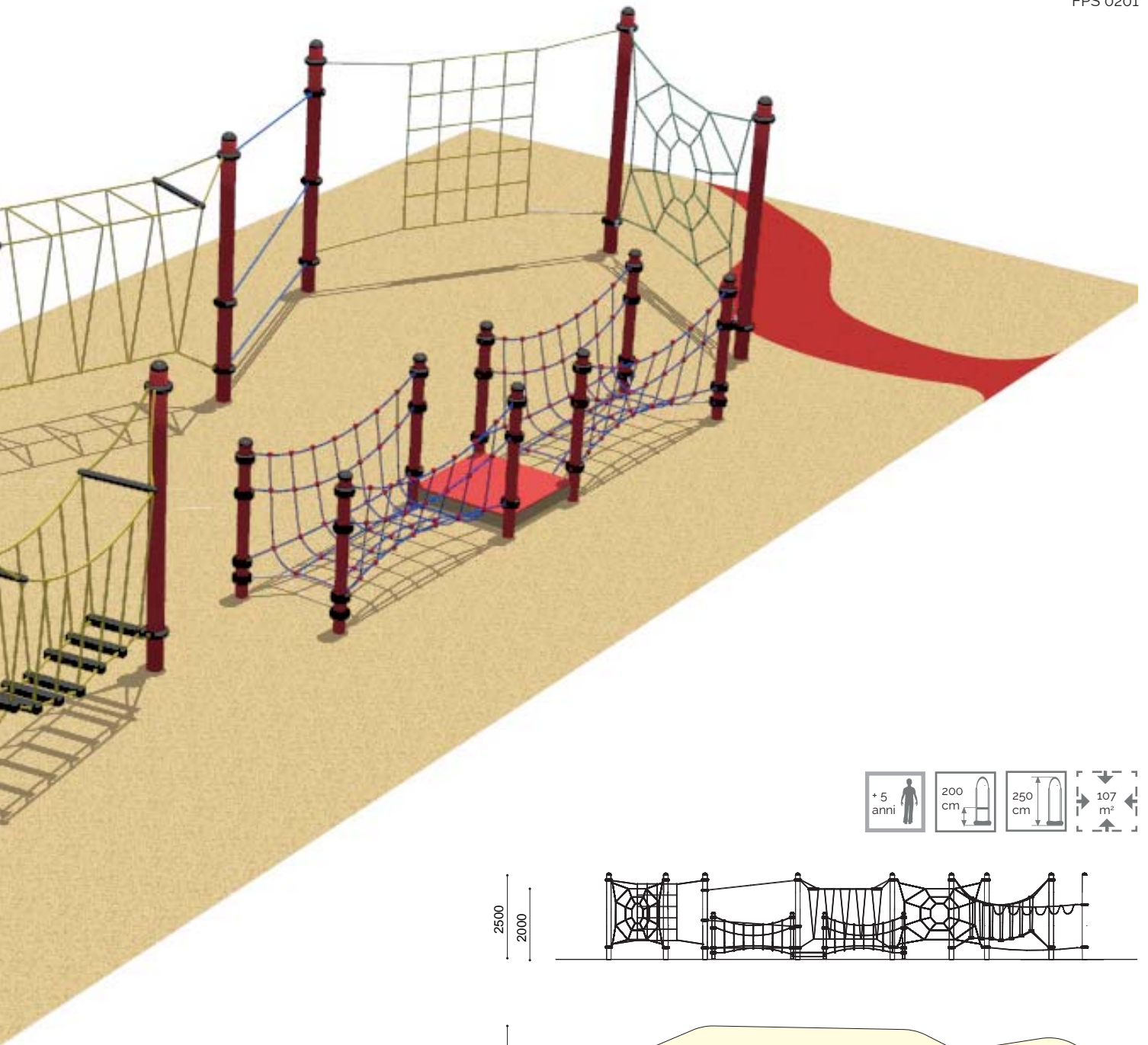

E-GAMES

LA LINE DI GIOCHI INTERATTIVI



INTERACTIVE GAMES LINE



SPORT



PLAY



LEARNING

E-GAMES

GIOCHI INTERATTIVI

Apprendimento, reattività, giochi a squadre e tanto altro. I satelliti installati sulle superfici e sulle strutture, rendono interattivo il parco giochi. Collegati alla plancia ed inizia a giocare!

INTERACTIVE GAMES

Learning, reactivity, team player and more. Satellites installed on the surfaces and structures make interactive playground areas. Linked to dashboard and play!







Un campo di gioco che mette faccia a faccia gli avversari sfidandosi fino all'ultimo sensore. Un alto valore ludico unito all'attività fisica e adatto a tutte le età. Chi vincerà la sfida?

A playing field makes face to face you and your opponents taking until last sensor. An highest play value together with physical activity and suitable for all ages. Who wil meet the challenge?



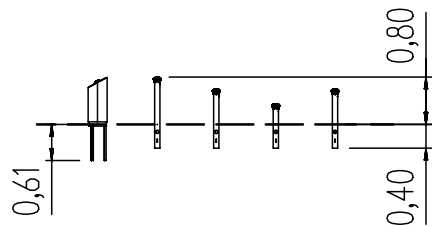

4 Modalità di gioco_ 4 Game mode

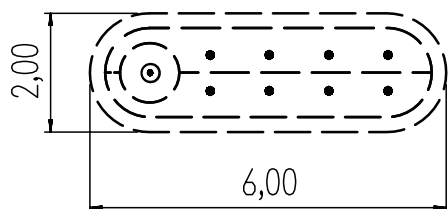

Attività

- Velocità
- Reattività
- Memoria
- Giochi a squadre

Activities

- Speed
- Reactivity
- Memory
- Team player



La line E-GAMES è anche INCLUSIVA





Un grand campo da gioco versatile e con diverse attività. Modella il terreno a tuo piacimento per migliorare l'esperienza di gioco. Un alto valore ludico unito all'attività fisica e adatto a tutte le età.

A large and versatile playing field with different activities. Model the ground like you want to involve the gaming experience. An highest play value together with physical activity and suitable for all ages.



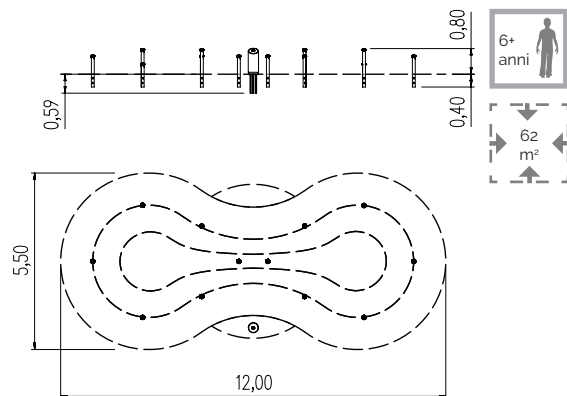
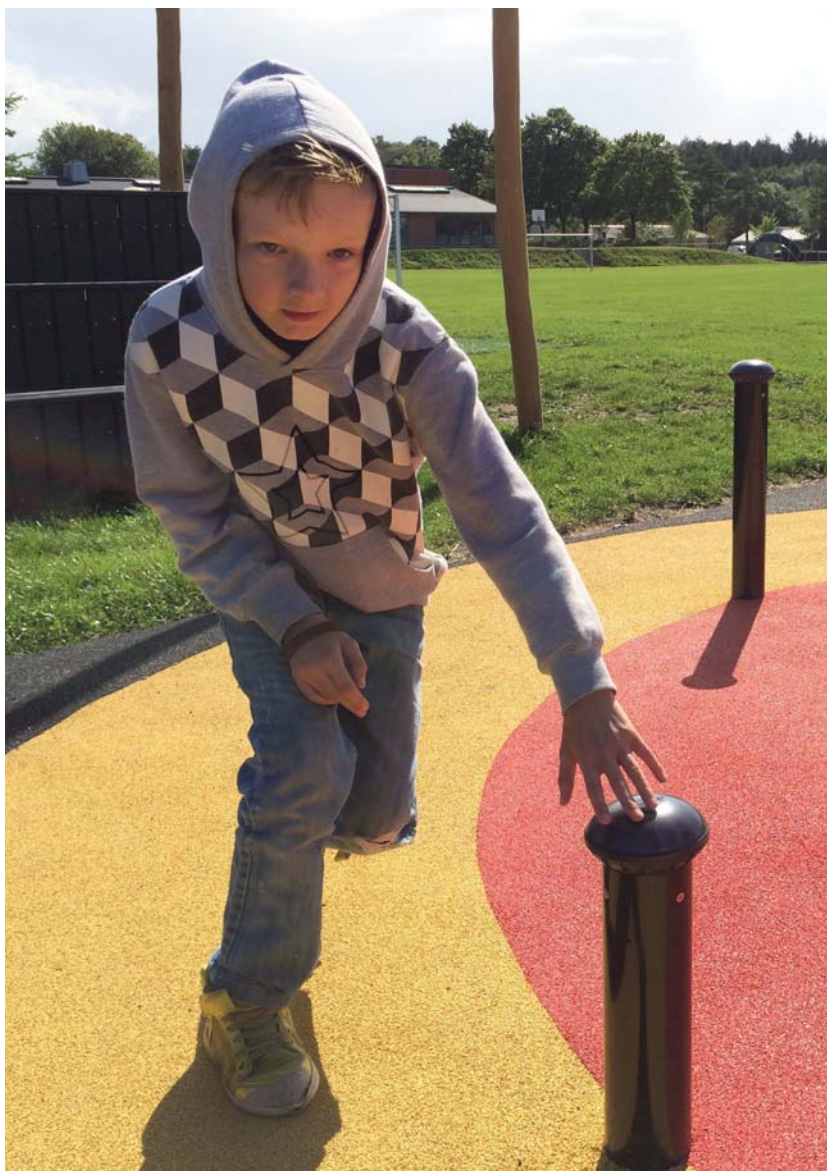

4 Modalità di gioco_4 Game mode



Attività

- Velocità
- Reattività
- Memoria
- Giochi a squadre

Activities

- Speed
- Reactivity
- Memory
- Team player

DAI LA FORMA CHE PREFERISCI
AL TUO CAMPO DI GIOCO



SPIDER - FPI 0300





La nuova generazione di strutture interattive. Le sue dimensioni ed il suo design innovativo rendono lo Spider una scultura all'interno del parco giochi. Costruito interamente in acciaio inossidabile e disponibile con 12 o 16 satelliti

The new generation of interactive structures. Its dimensions and innovative design make it a sculptural construction inside the playground area. Completely stainless steel made of with 12 or 16 satellites available

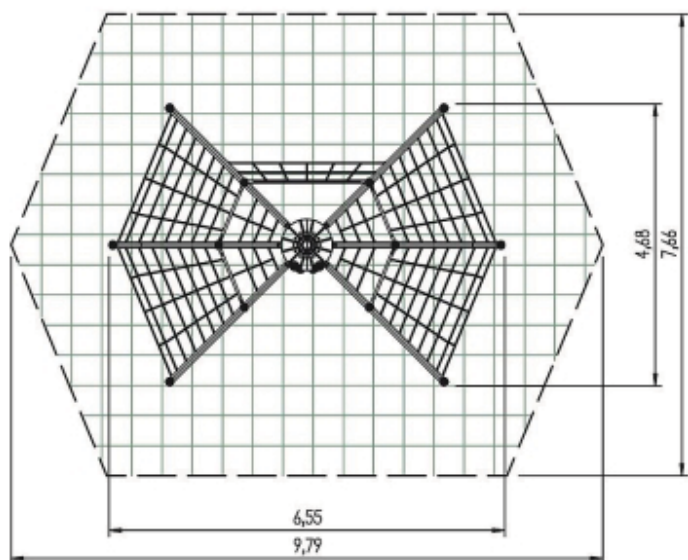
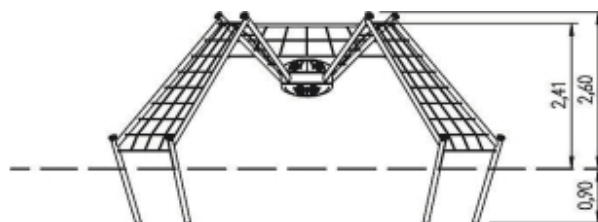

Attività

- Velocità
- Reattività
- Logica
- Giochi a squadre

Activities

- Speed
- Reactivity
- Logic
- Team player

3 Modalità di gioco

3 Game mode



e-Wall - FPI 0100

Il "muro interattivo" che unisce, movimento, gioco e apprendimento

An interactive play and learning wall, providing plenty of physical movement



Connettiti all' e-Wall con il tuo Smartphone o tablet e scegli o crea i tuoi giochi

Connect to e-Wall with your smartphone or tablet and play or create your new games



Step 1. Seleziona "Crea un nuovo esercizio"
Select "Create a new exercise"

Step 2. Scegli un titolo e clicca "Create"
Choose a title, and click create



Step 3. Crea nuovi problemi da risolvere
Create your question

Step 4. Crea possibili risposte
Create possible answers

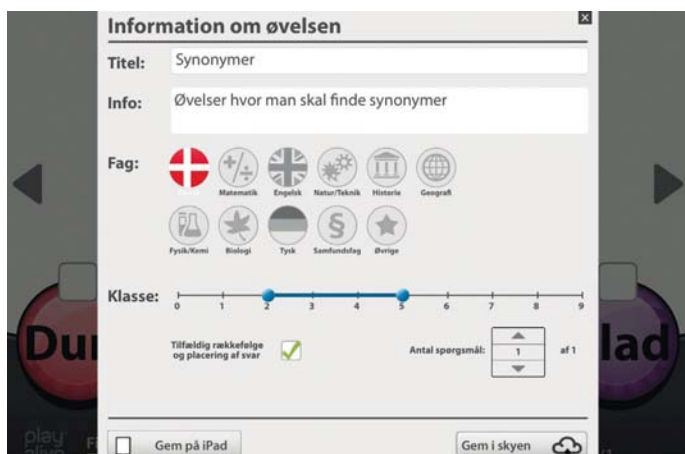

Step 5. Scegli fra diverse opzioni e salva l'esercizio
Choose between different options and save your exercise

Step 6. L'esercizio è pronto per essere utilizzato
The exercise is ready for use.





**fun
PLAY**
bimbo 

La Linea FunPlay Bimbo è pensata per i più piccoli con un'età compresa tra 2 e 6 anni.

Dalle forme morbide e sicure nascono percorsi guidati e interattivi che creano stupore e divertimento in un mondo di colori.

FunPlay Bimbo is designed for younger children aged 2 to 6.

Comfortable and safe shapes, creates adventurous and interactive tracks creating amazement and fun in a colourful world.

 [web link](#)







Talk-Talk play

Fiori parlanti

Talking flowers

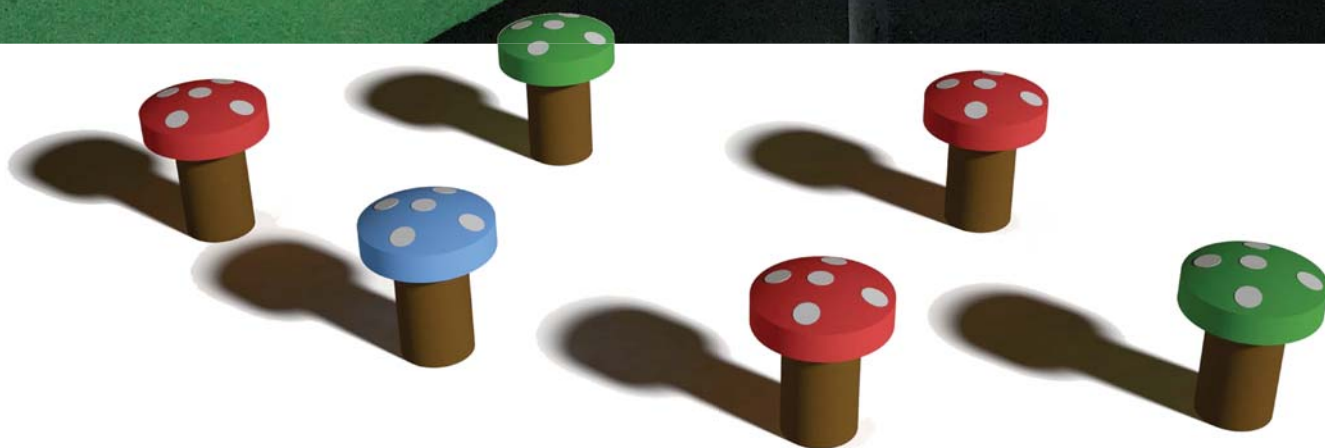

Sedute 4D in EPDM con scocca in Polistirene ad alta densità

4D Sitting Mushrooms covered by EPDM and high density polystyrene made of for basements



Pannelli tematici e didattici adatti a bambini di età prescolare

Didactical and with different themes panels suitable for pre-school-age children



Pannelli da 15 mm con finiture goffrate

Panels 15 mm thickness with embossed finishes







Inventa e disegna il tuo pannello!

Strutture morbide pensate per scuole
dell'infanzia e parchi giochi per i più
piccoli

Soft structures designed for
kindergartens and school playgrounds
for the little ones

 [web link](#)





+ 1
anni

34
cm

273
cm

13
m²

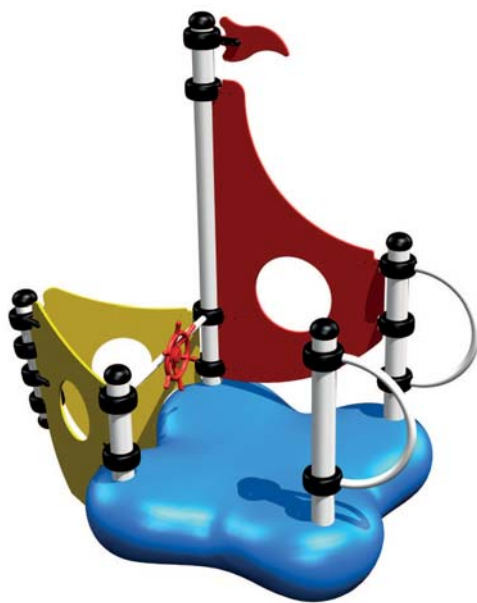

FPB 0001

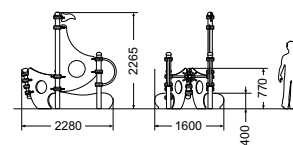
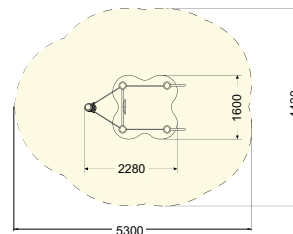

+ 1
anni

45
cm

440
cm

25
m²

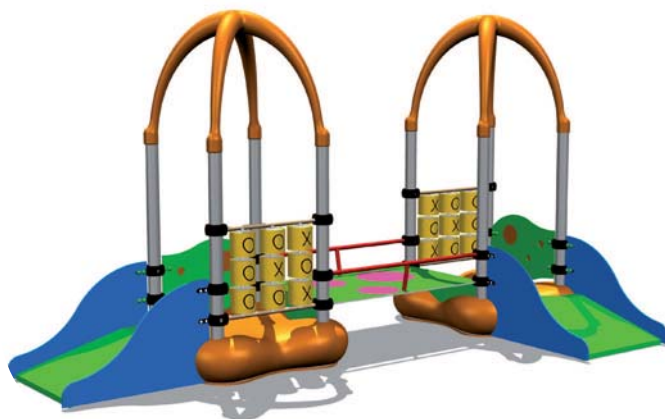

FPB 0002

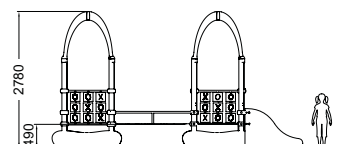
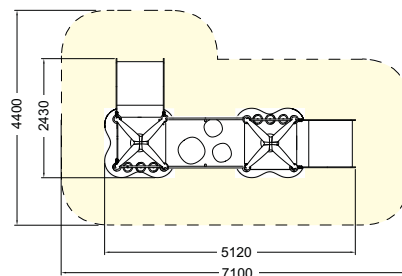

+ 1
anni

49
cm

278
cm

35
m²

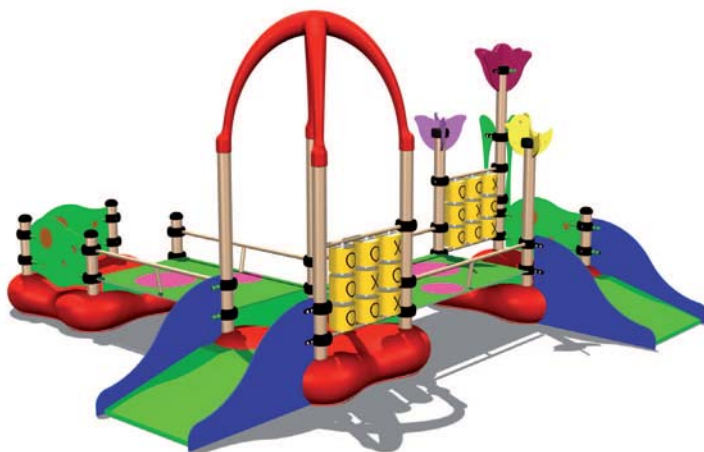

FPB 0003

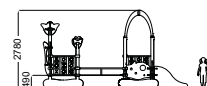
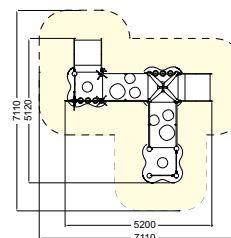

FPB 0004

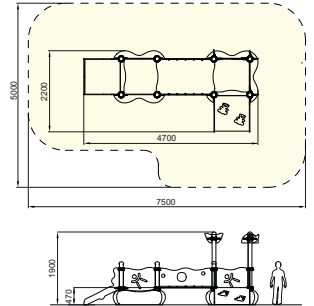
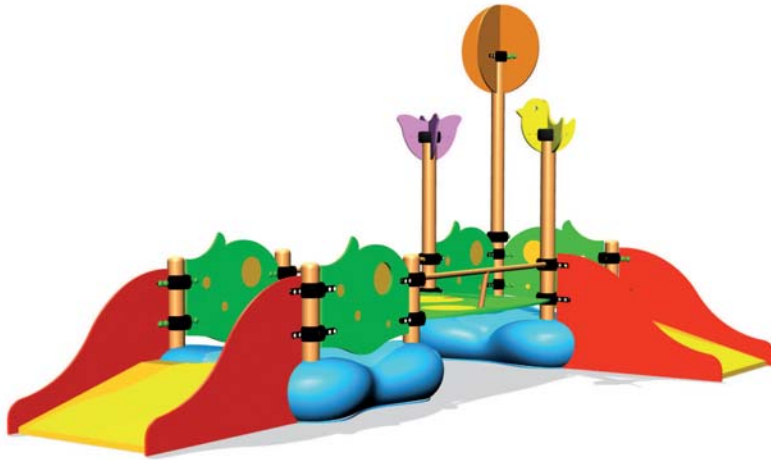
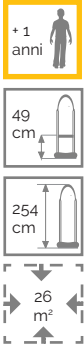

FPB 0005

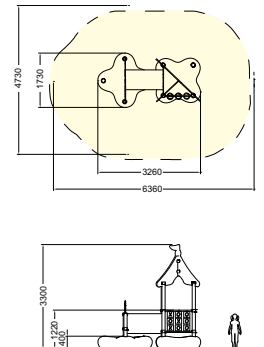
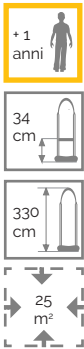

FPB 0006

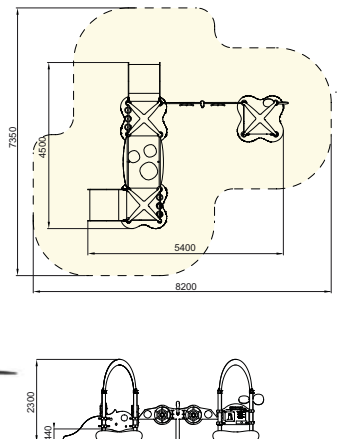
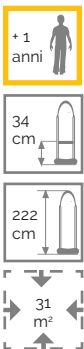

FPB 0007

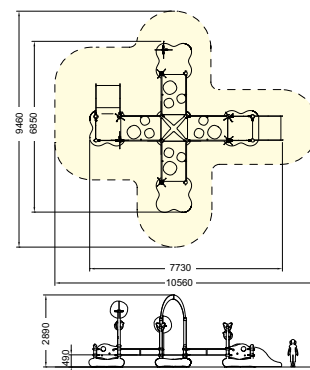
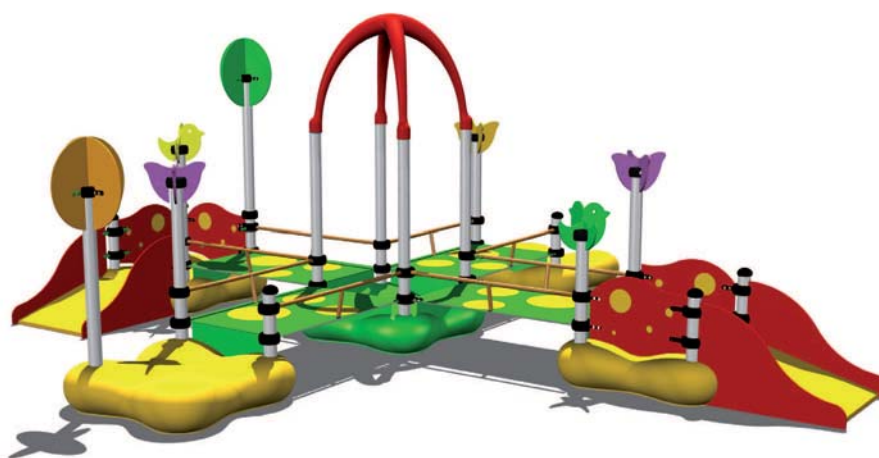

FPB 0008

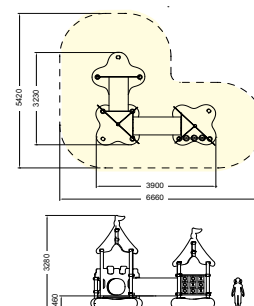
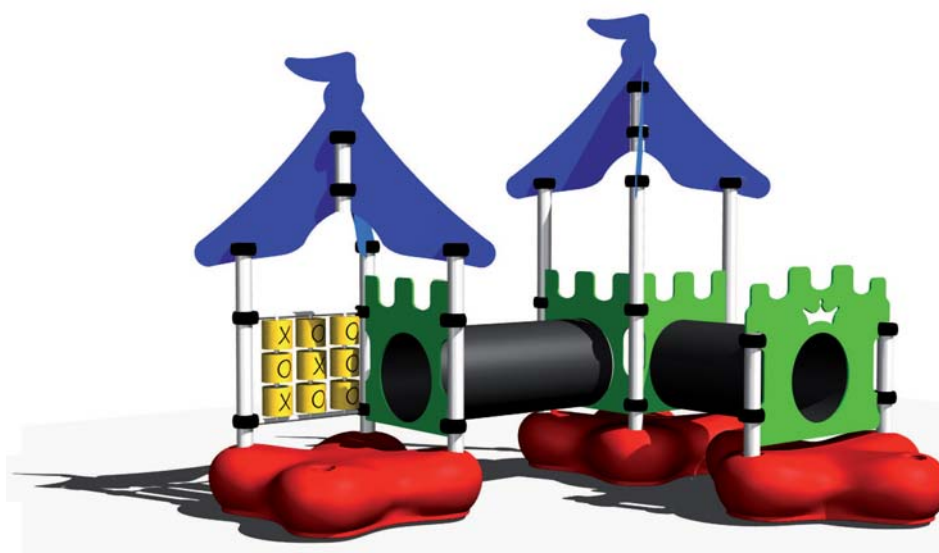

FPB 0009

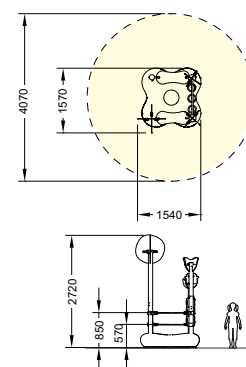
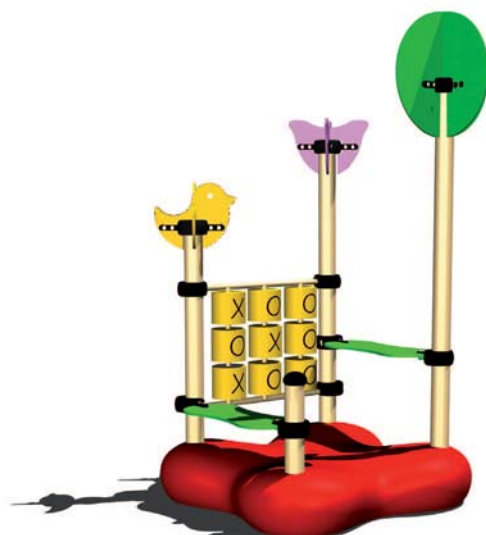

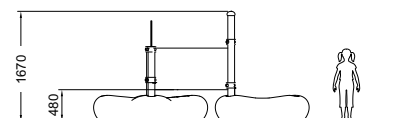
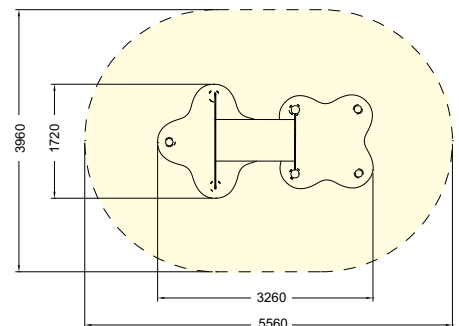
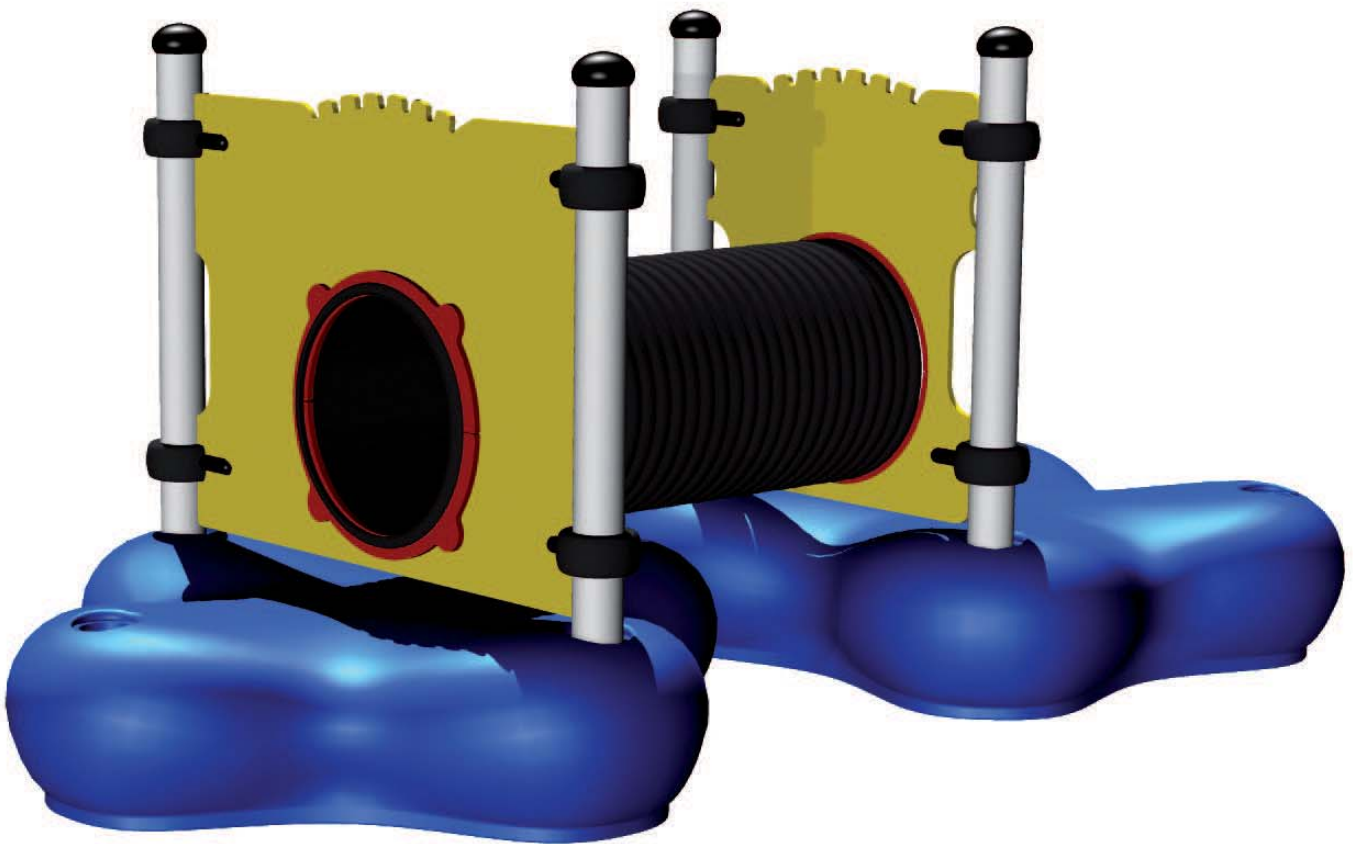
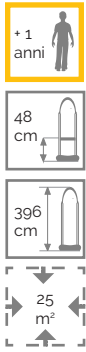

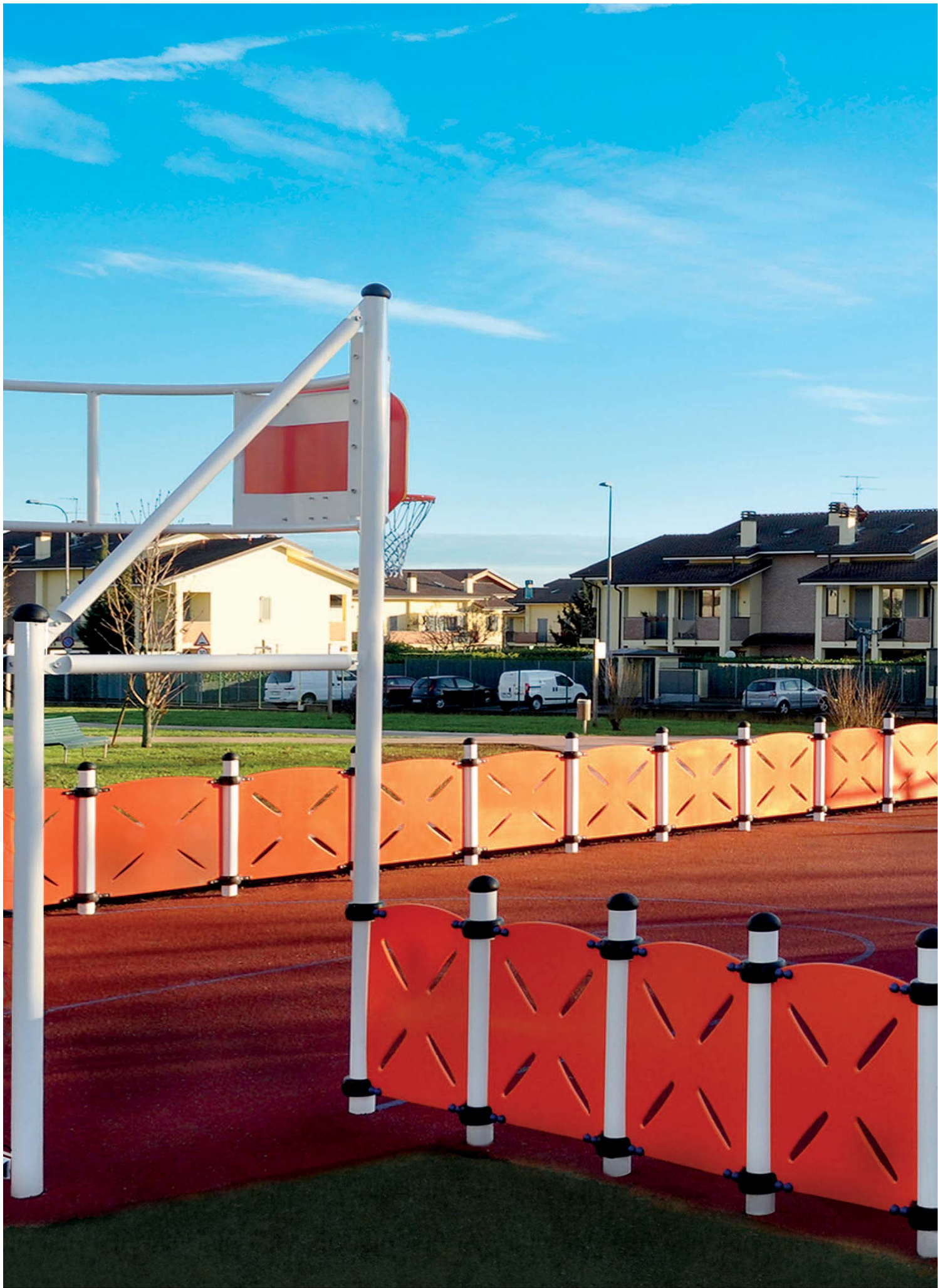



fun PLAY ARENA

ARENA

La linea dalle forme morbide e dai colori vivaci.

I pannelli in polietilene rotostampato, fonoassorbenti e antiurto, garantiscono sicurezza e massima qualità del gioco.

A soft and bright-colours shape line.

Sound-absorbent and anti-impact panles created by rotational moulding, ensuring the highest safety and quality of the play





ARENA

Comune di Como



Arena con pannelli rotostampati



ARENA

Comune di Legnano





ARENA

Strutture per campi da gioco sportivi adatte a tutte le età. I pannelli con struttura a "camera d'aria" riducono la possibilità di traumi durante il gioco.

Facilities for sports playgrounds suitable for all ages. The "inner space" system of the panels reduce impact damages during the game.



web link







FA SF002

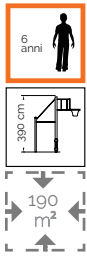
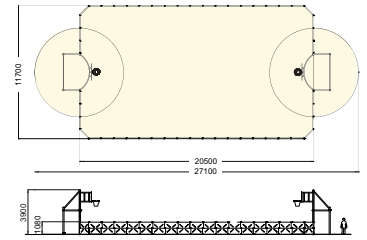

FA SxFO04

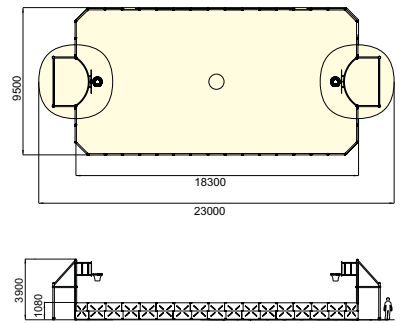

FA SF007

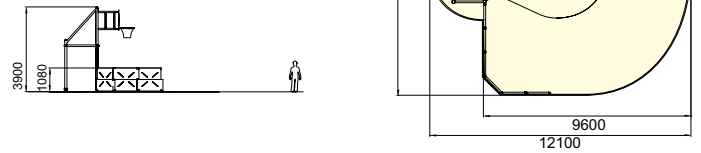

FA SF008

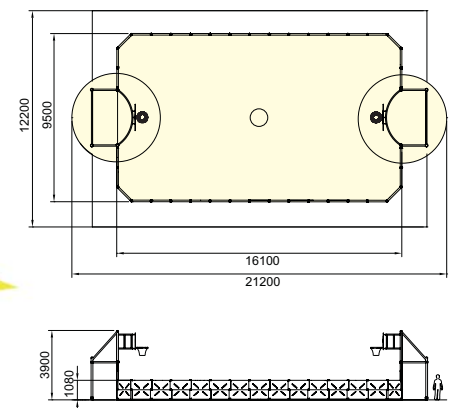

ARENA

FA SF003

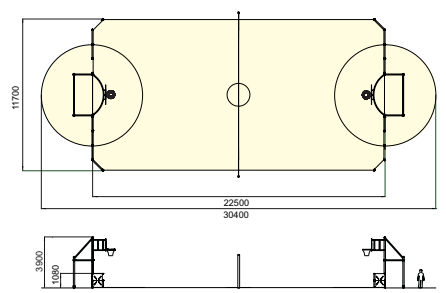
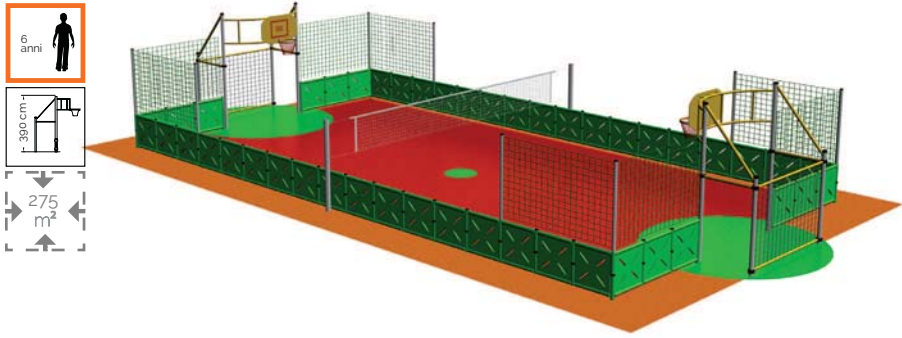

FA SF005

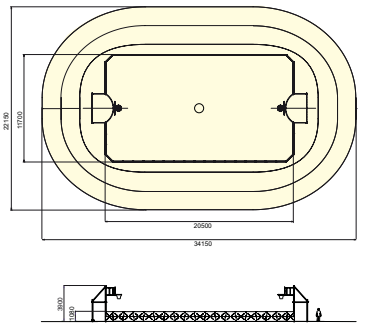
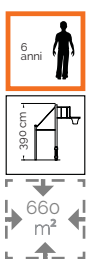
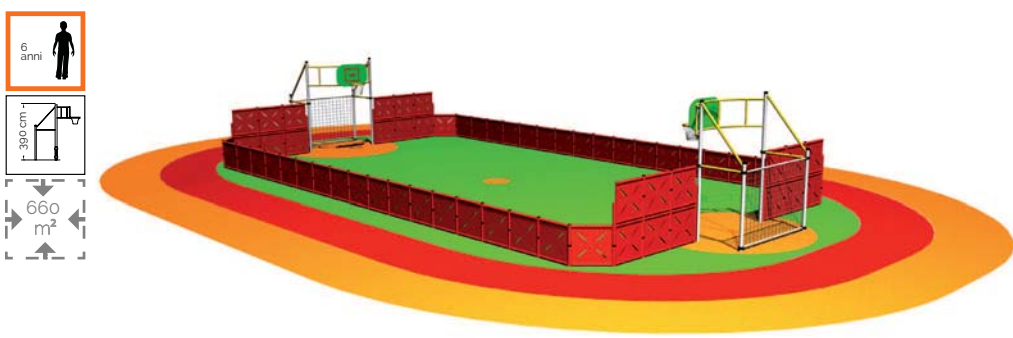

FA SF006

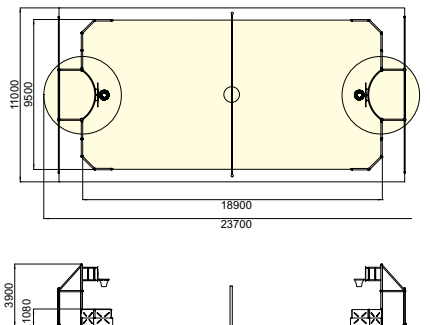

FA SF001

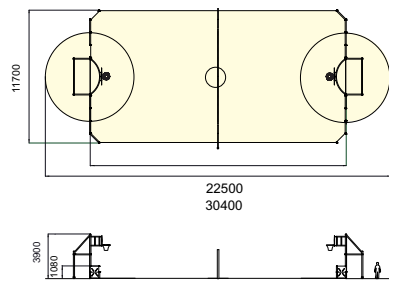
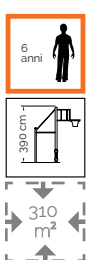
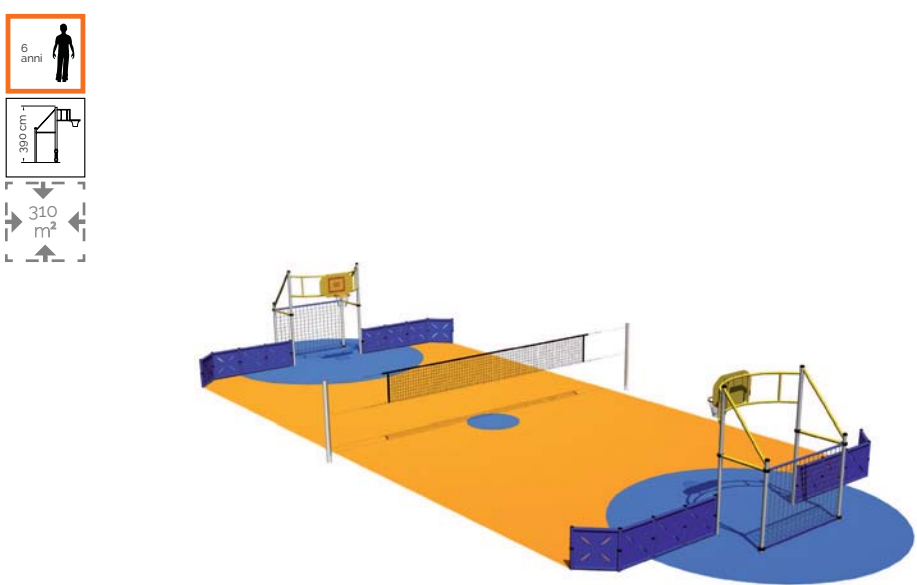

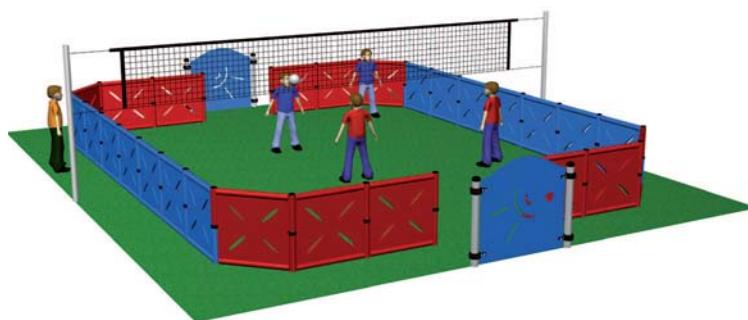
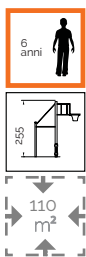

FA SF009

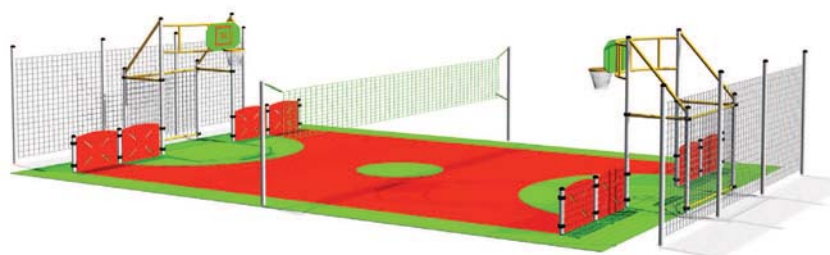
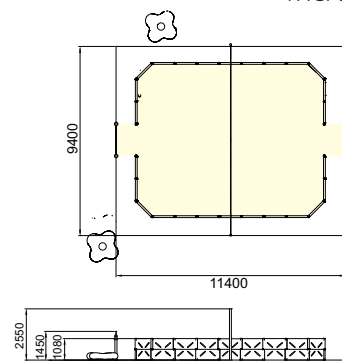

FA ST002

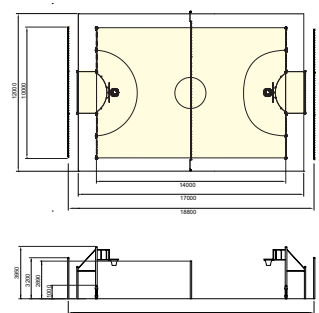

FA ST001

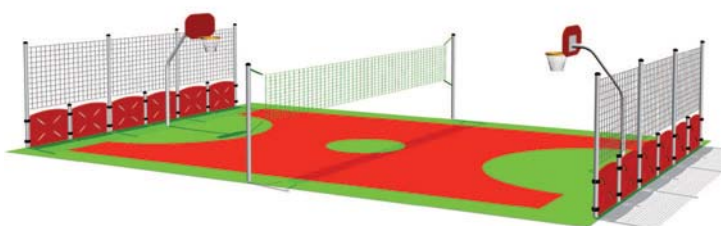
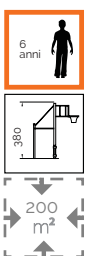
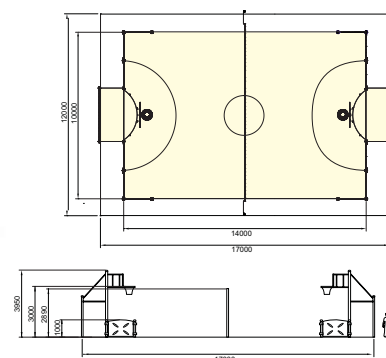

FA ST003

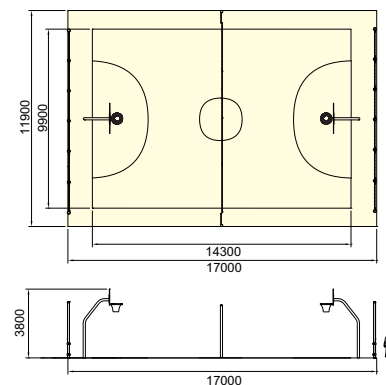

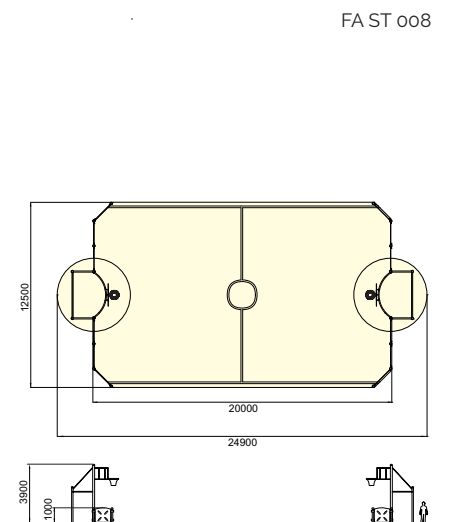
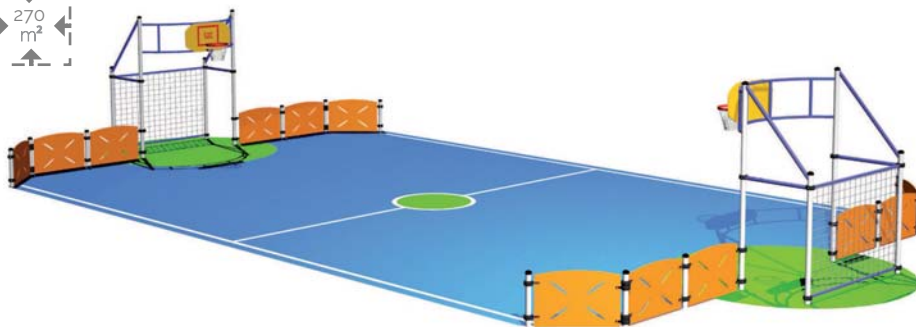
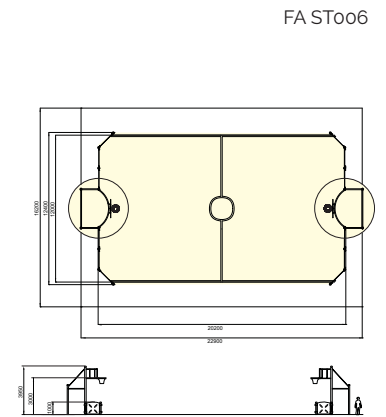
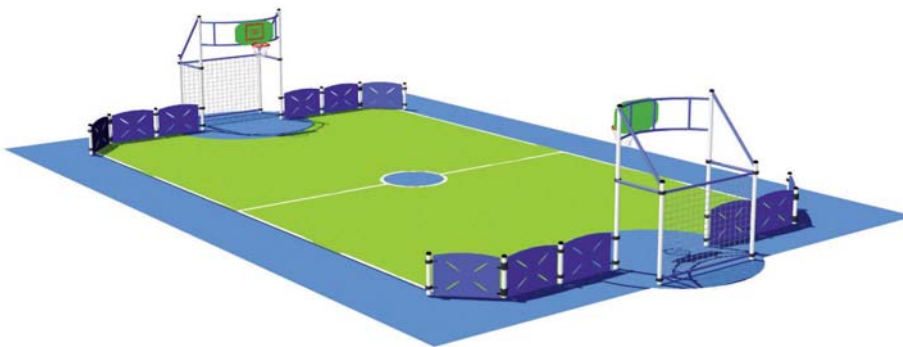
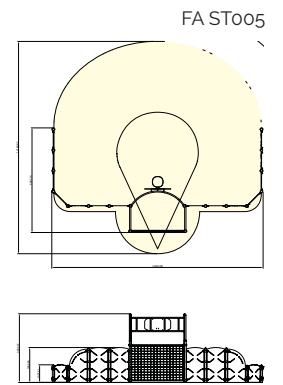
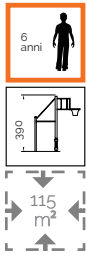
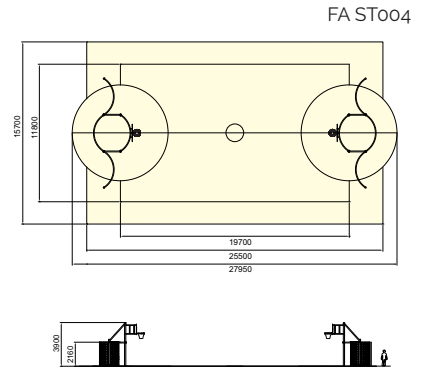
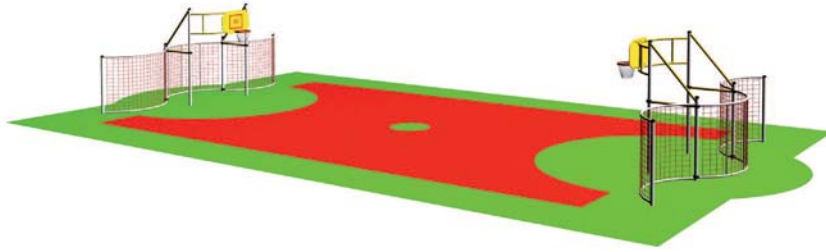
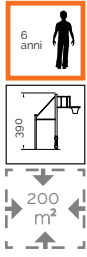

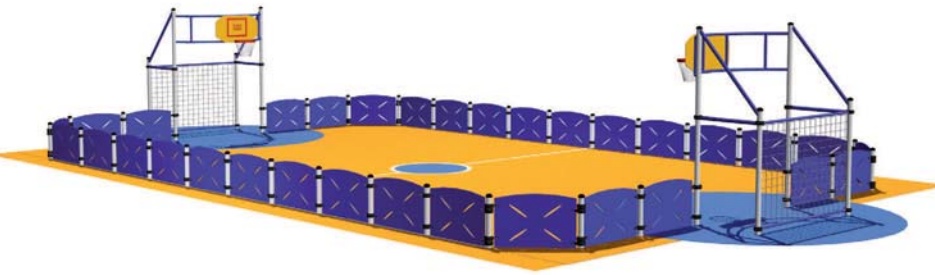

FA ST007

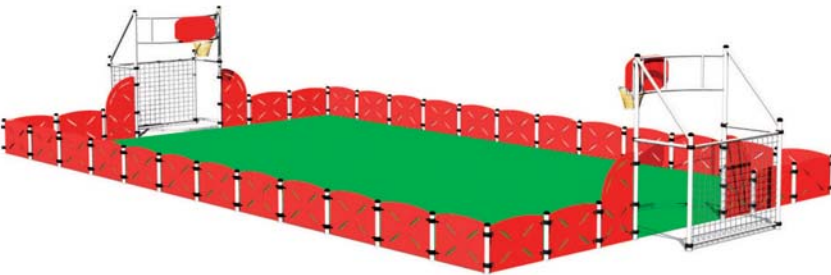
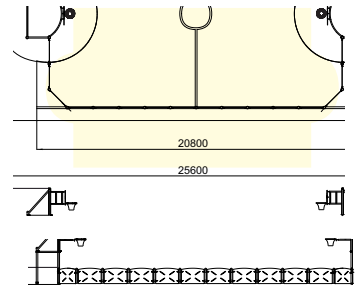

FA ST 009

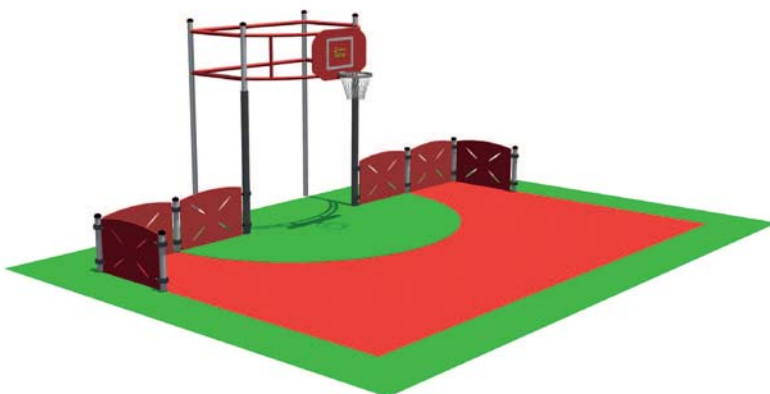
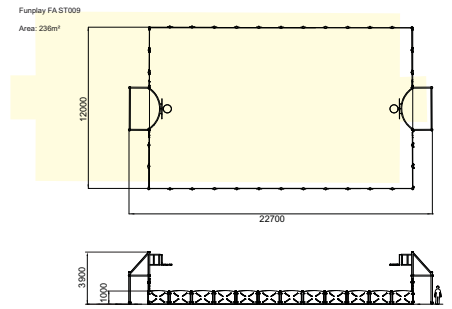

FA ST 010

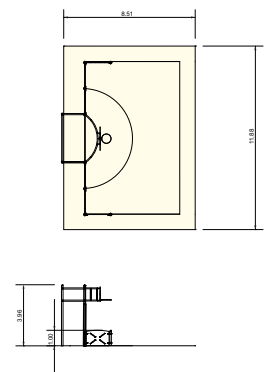

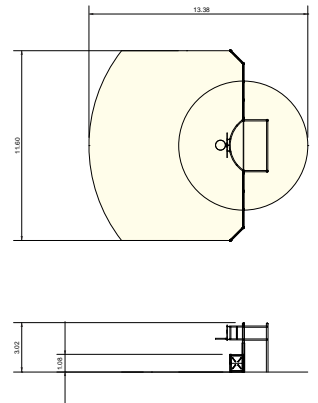
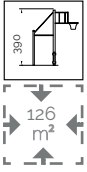
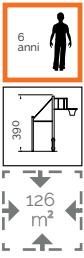

CALORIE CONSUMATE

150 Cal - 30 Minuti

BURN CALORIES

150 Cal - 30 Minutes







fun
PLAY
TEMA

TEMA

Con i suoi pannelli tematizzati, i giochi si trasformano in giungle, castelli e navi creando luoghi e avventure immaginarie in grado di stimolare la fantasia di ogni bambino.

His themed panels transform games in jungles, castles and ships creating adventure and imaginary places able to stimulate fantasy of every child.





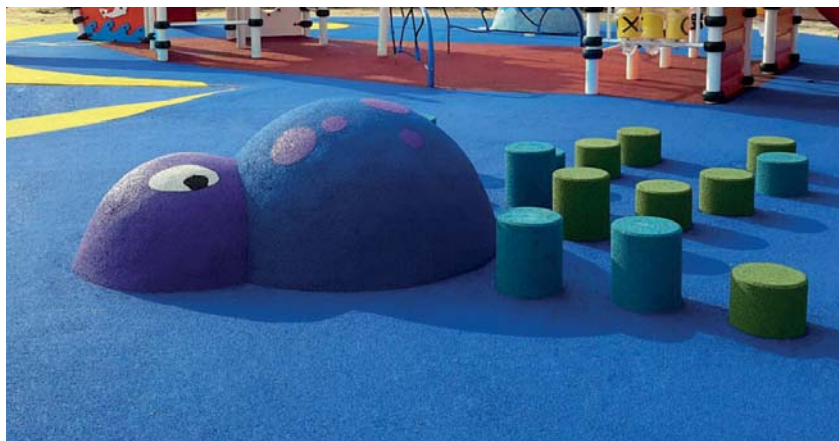



Latina - Parco giochi comunale

Area giochi ispirata al mare con elementi 4D e struttura ludica a galeone

Structures polyethylene UV resistant and scratch-resistant embossing.





Utilizza i FunPlay 4D per personalizzare il tuo parco

Use FunPlay 4D to customize your playground area



Interactive playground Area





Capodichino Airport



**Grazie ai pannelli
tematizzati,
i giochi si trasformano
in montagne, castelli e
macchine immaginarie
stimolando la fantasia
di ogni bambino.**







Napoli - Areoporto Capodichino
Naples - Capodichino Airport

Area Giochi presso l'aeroporto Capodichino con struttura a doppia torre tematizzata ad aereo con arrampicata obliqua

Structures polyethylene UV resistant and scratch-resistant embossing.

Dubai - Swiss International Scientific School



Area giochi con pannelli in polietilene ad alta resistenza agli urti e ai raggi UV. Pannelli lavorati tramite macchina CNC con innumerevoli possibilità di tematizzazione.

Structures polyethylene UV resistant and scratch-resistant embossing.





The Castle







OMAN_Muscat - Nuova area giochi
New playground area

Realizzazione di una struttura a montagna e posa della
pavimentazione antitrauma FunShock

Mountain structure and FunShock flooring (anti-shock flooring)
realization

TEMA

Il castello e l'orto magico...

Le sorprese nei parchi gioco TEMA non son mai finite

Use FunPlay 4D to customize your playground area







Playground Area Albarola Square















TEMA

Crea nuove avventure con le strutture tematizzate della linea TEMA

Create new adventures with themed structures of TEMA line



web link







FT 001

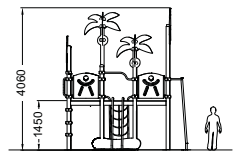
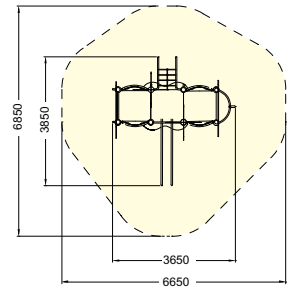

FT 002

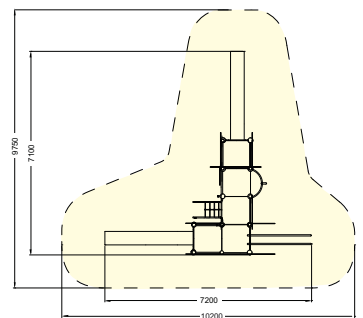

FT 003

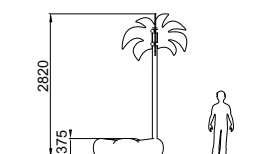
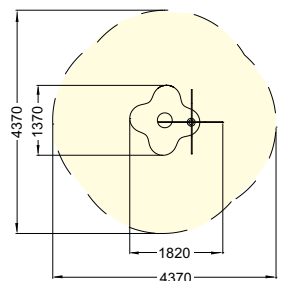

FT 004

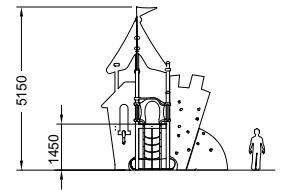
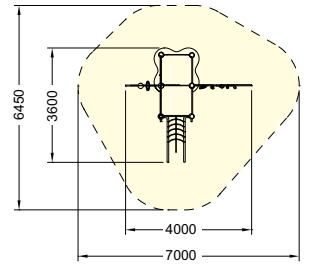

FT 005

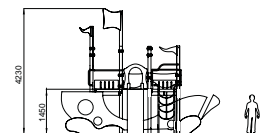
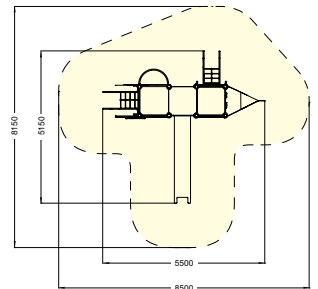

FT 006

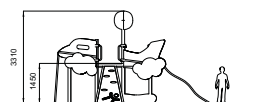
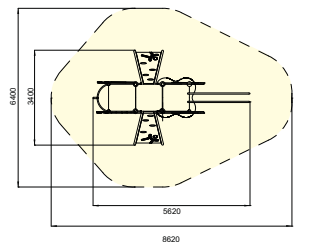
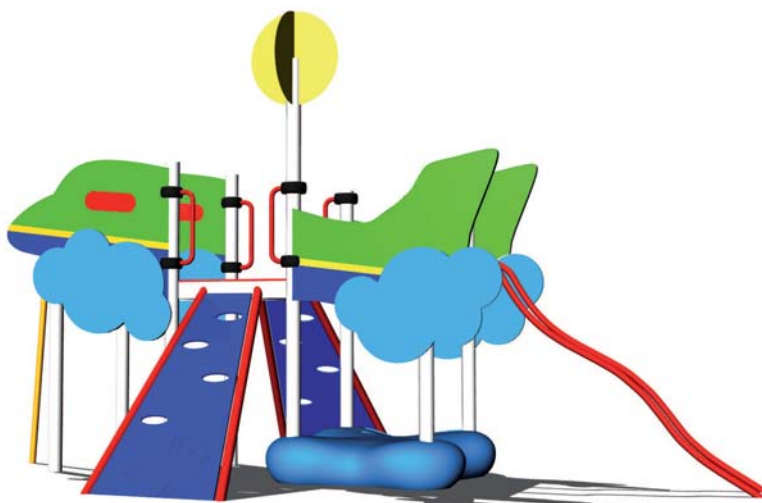

3+
anni

145
cm

557
cm

32
m²



FT 007

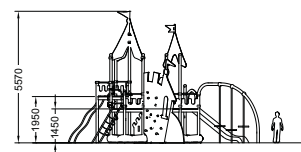
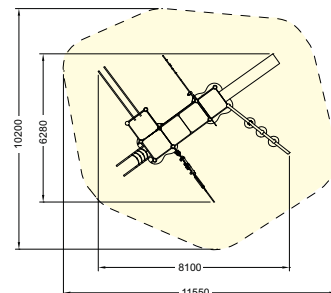

3+
anni

195
cm

390
cm

75
m²



FT 008

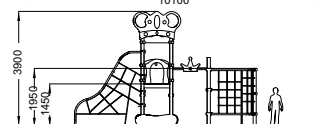
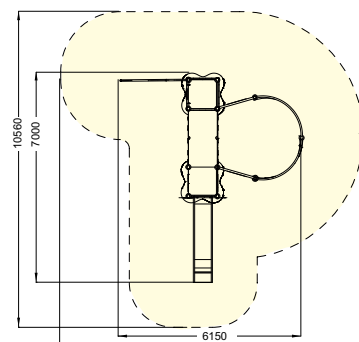

3+
anni

250
cm

534
cm

195
m²



FT 009

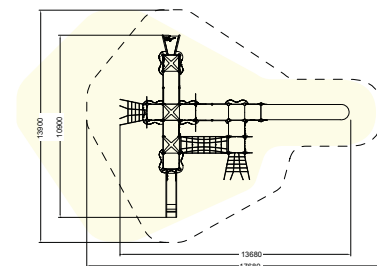

FT 010

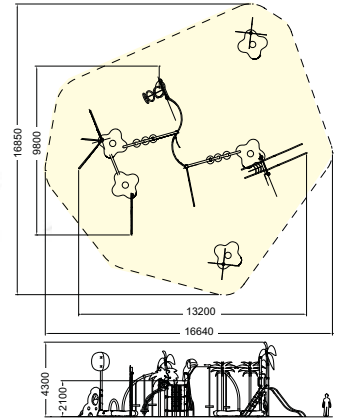

FT 011

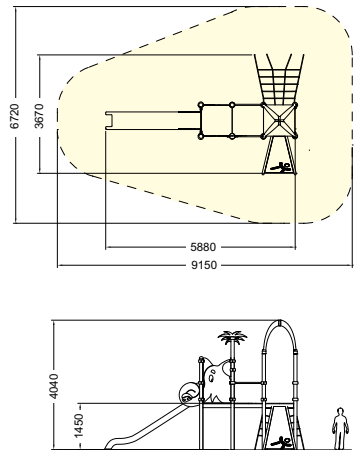

FT 017

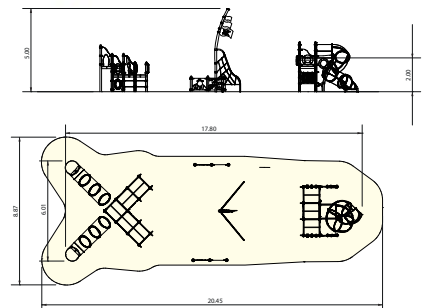



FT 014

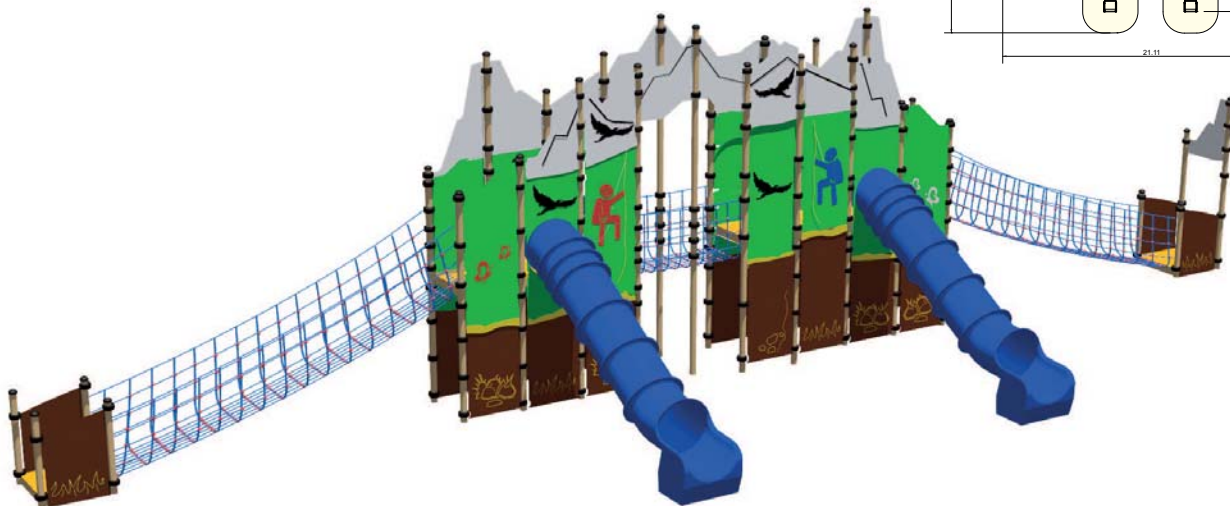
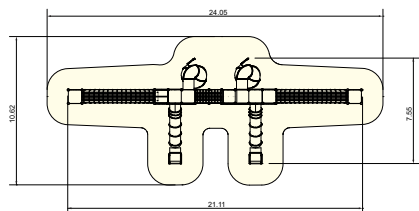
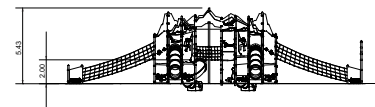

FT 012

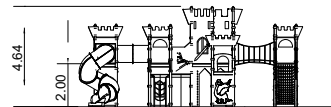
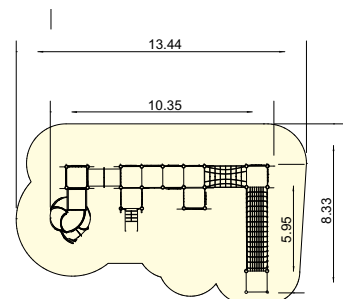

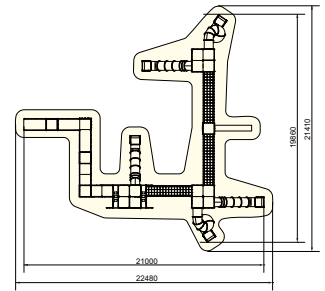
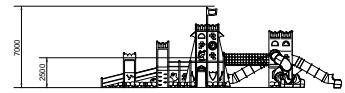
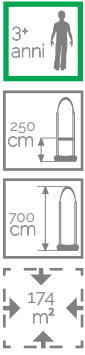





**fun
PLAY**

4D



FunPlay 4D
una nuova linea gioco composta
da morbide forme disegnate per
arrampicarsi e saltare sviluppando il
senso di equilibrio in modo divertente.

Funplay 4D
a line with soft shapes designed to
jump and climbing developing the
balance sense with fun

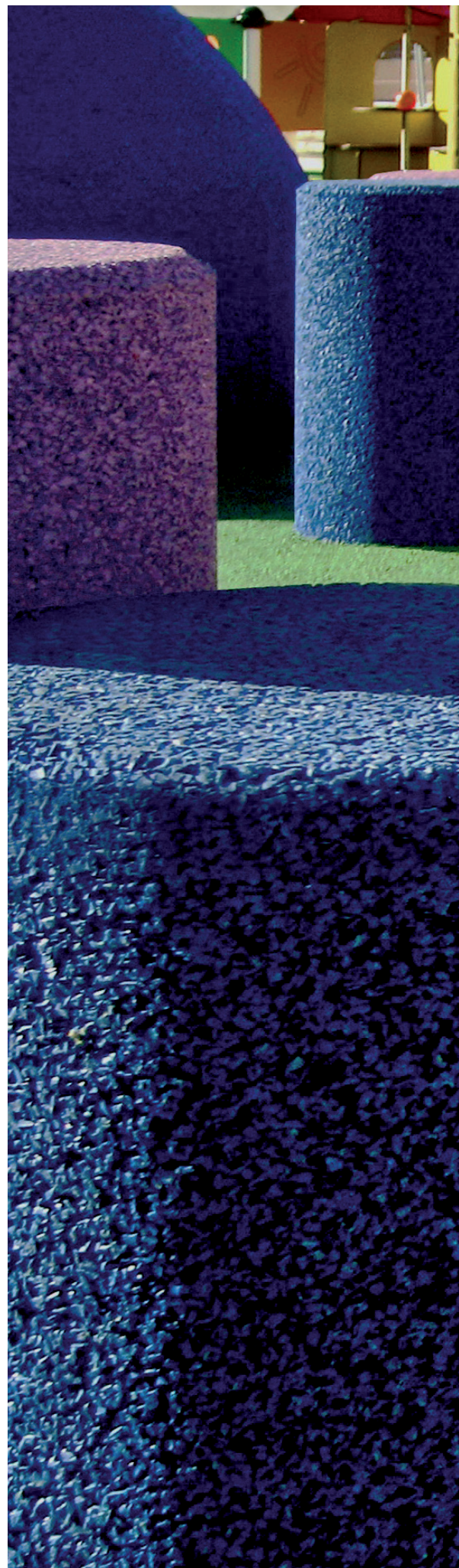





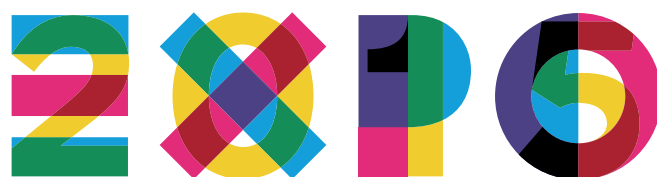

MILANO 2015



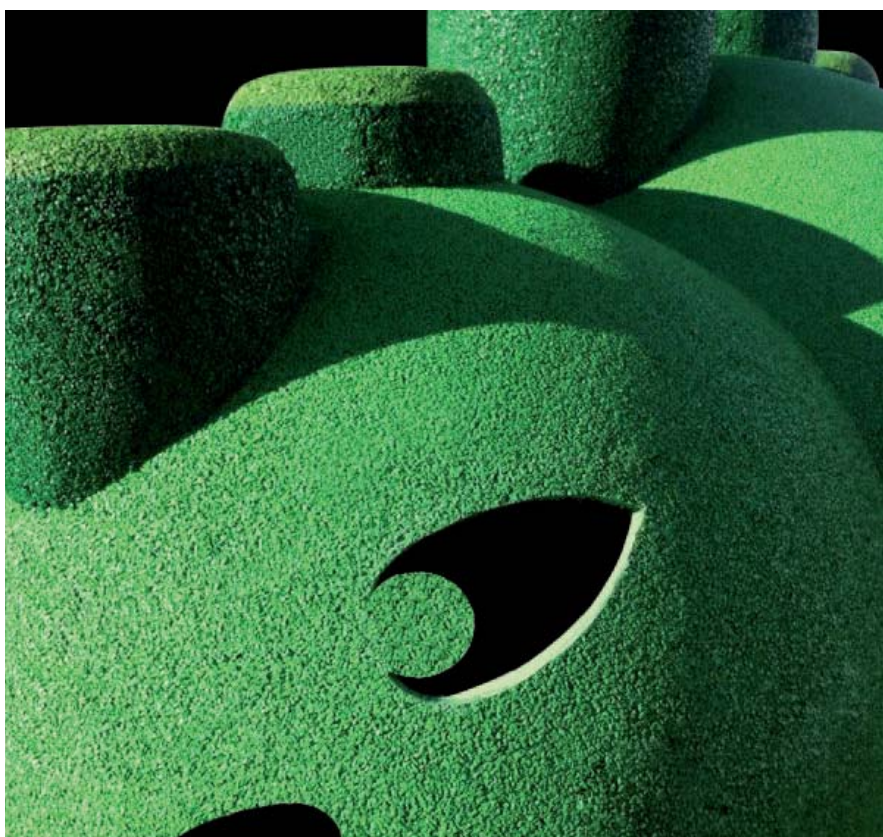

Sedute e punti di aggregazione



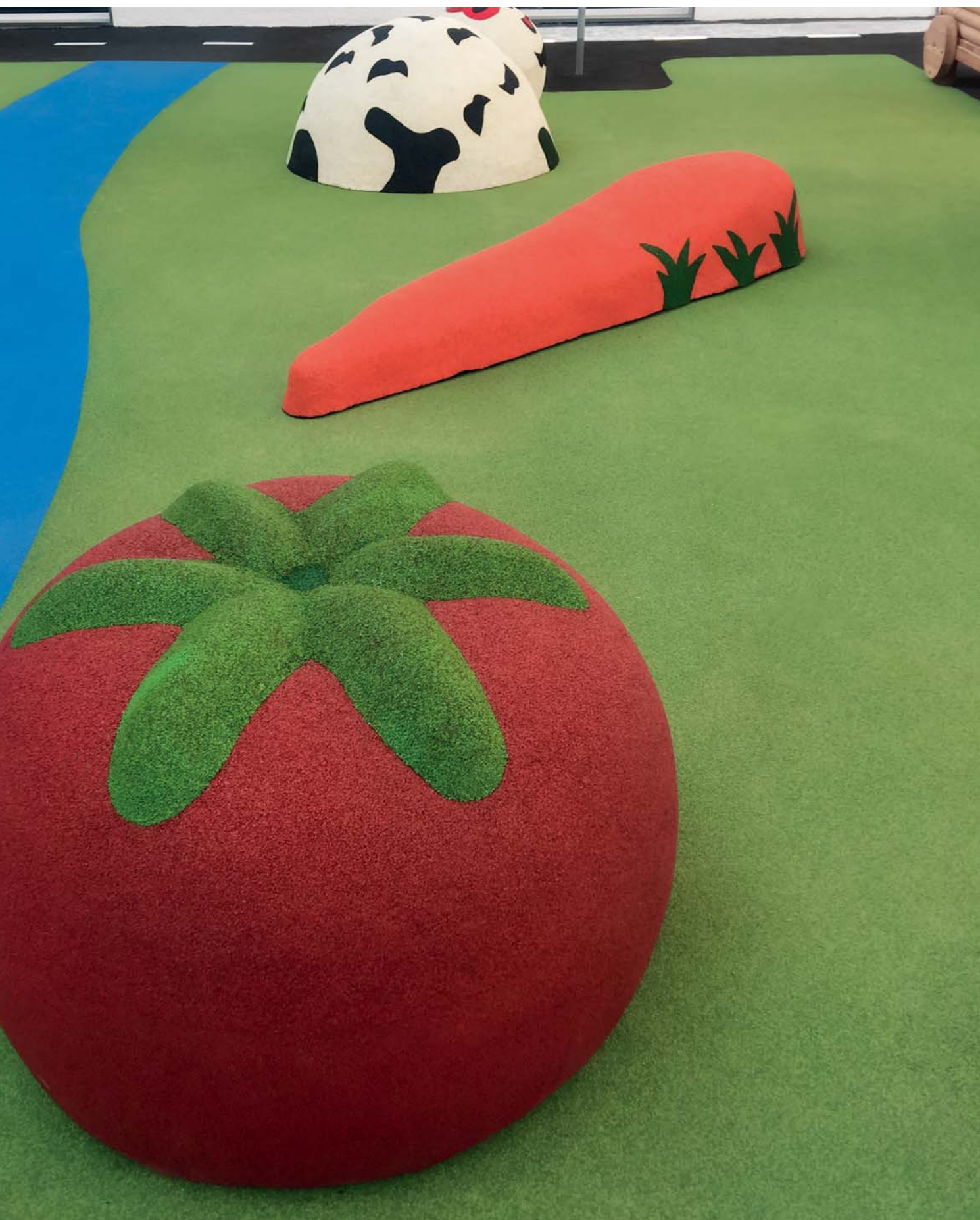

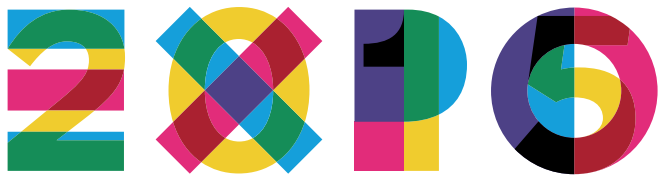

MILANO 2015

IL POMODORO



IL PIRATA



L'AEREO





Forme morbide in 4D
per far volare l'immaginazione dei
bambini. Elementi realizzati grazie
all'uso di moderne tecnologie

Soft shapes in 4D
to fly children's imagination.
Elements realized using the most
modern technologies.

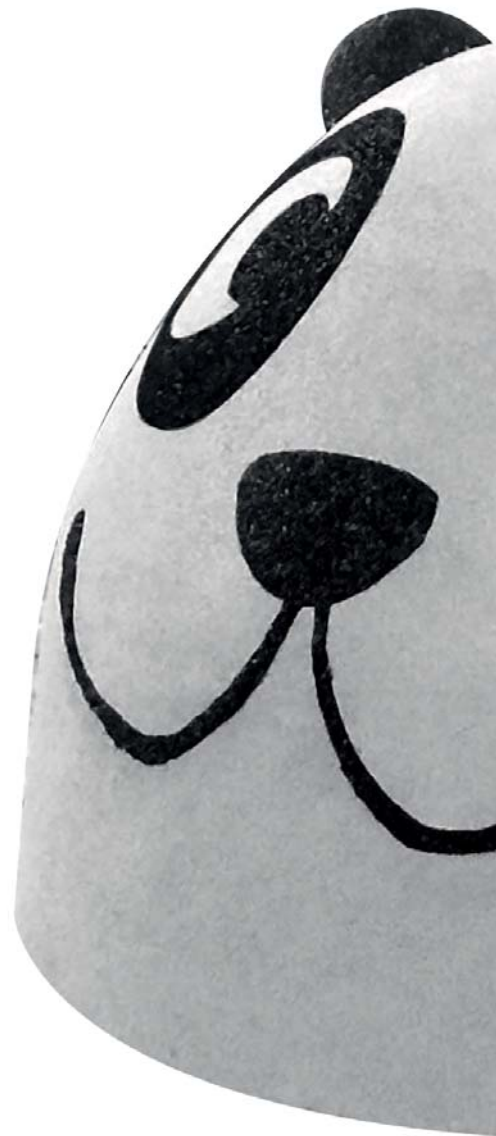

PROGETTA IL TUO 4D!
DESIGN YOUR 4D!



Rivestimento in EPDM con finitura speciale Anti UV
Covered by EPDM rubber with Anti-UV finishing

FP4D 0002

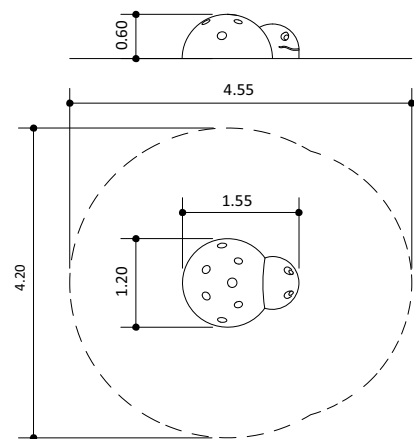

FP4D 0004

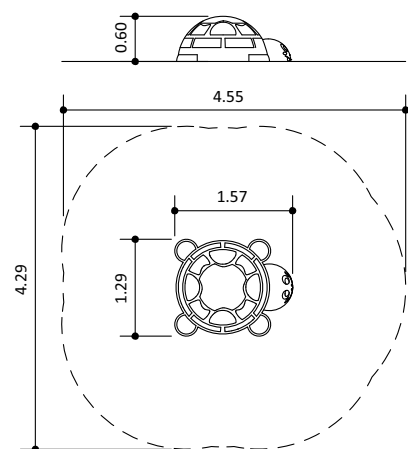
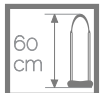

FP4D 0007

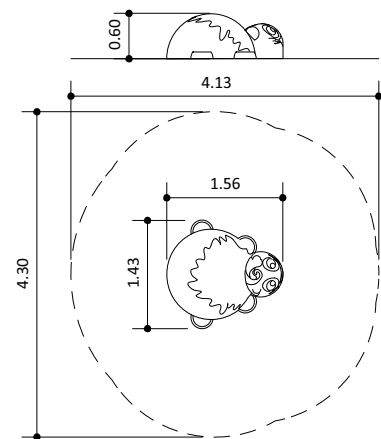
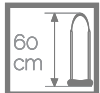

FP4D 0011

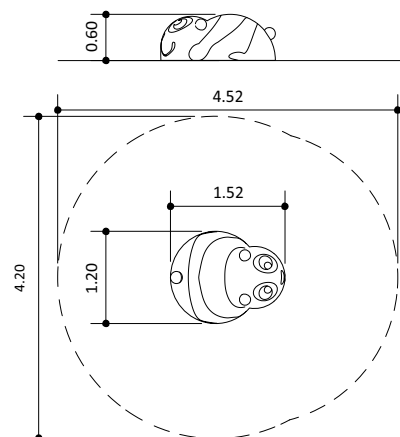
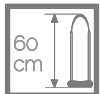

FP4D 0012

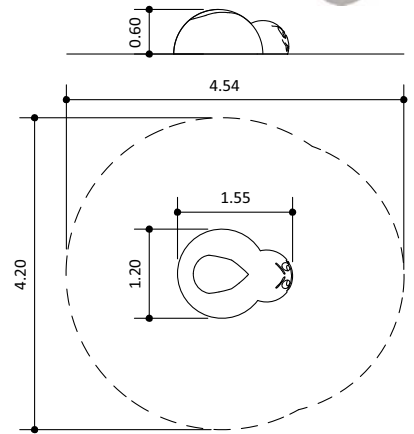
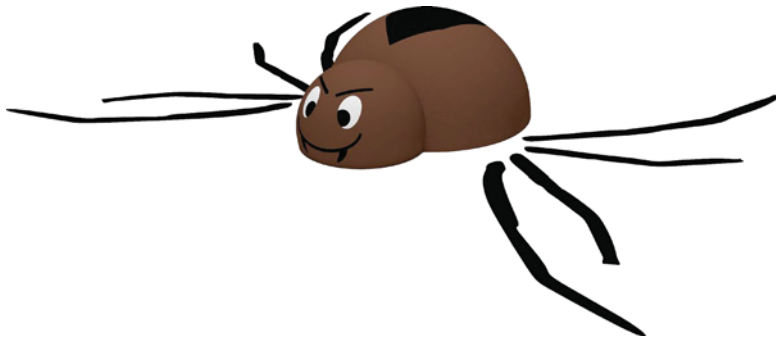

FP4D 0026

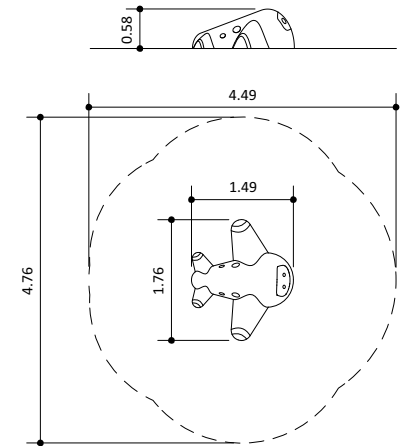
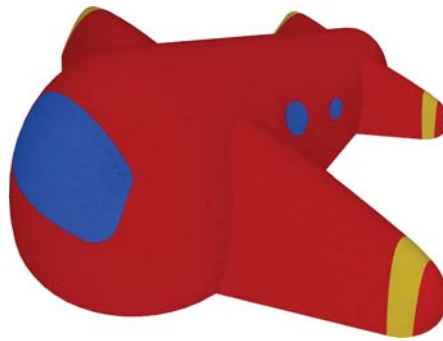

FP4D 0027

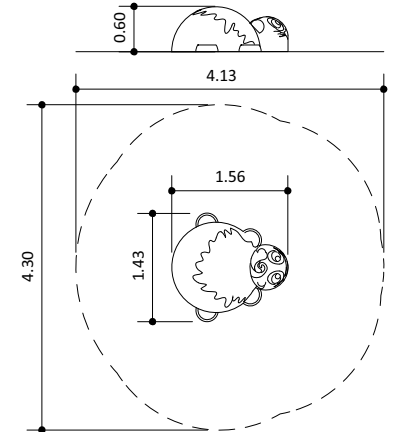

FP4D 0031

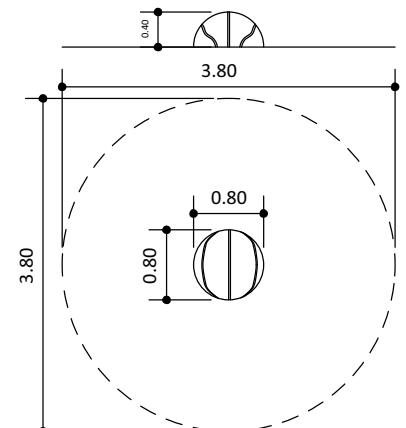

FP4D 0032

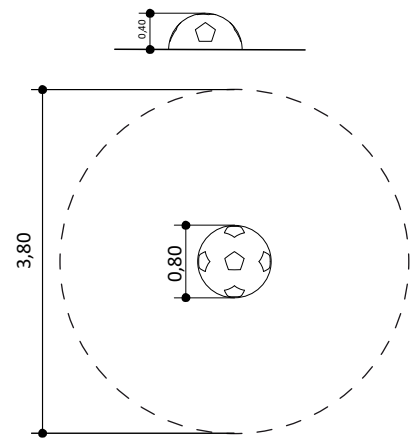
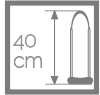

FP4D 0034

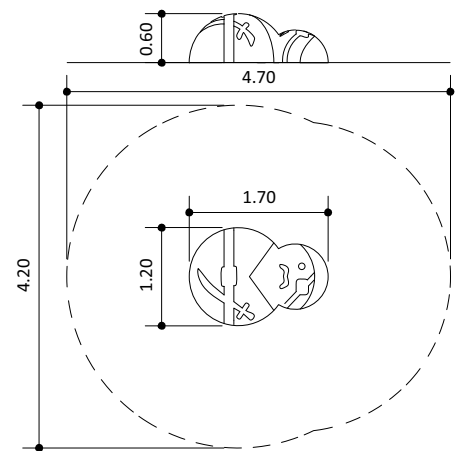

FP4D 0035

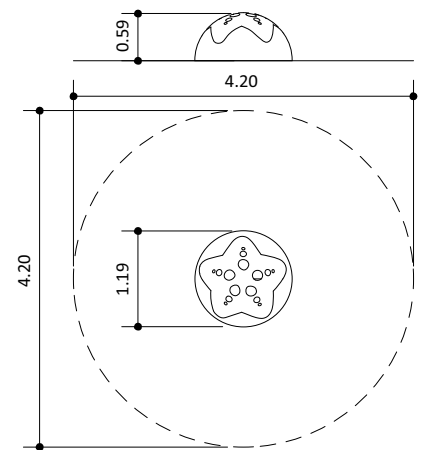

FP4D 0038

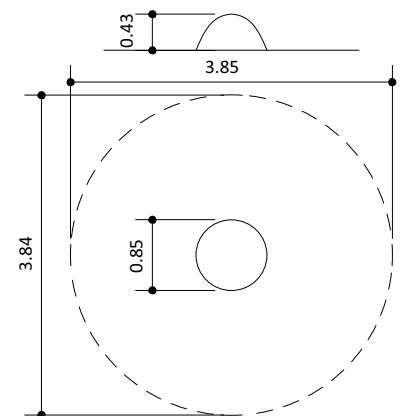
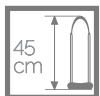

FP4D 0042

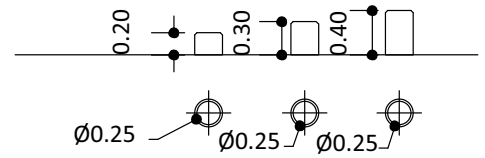
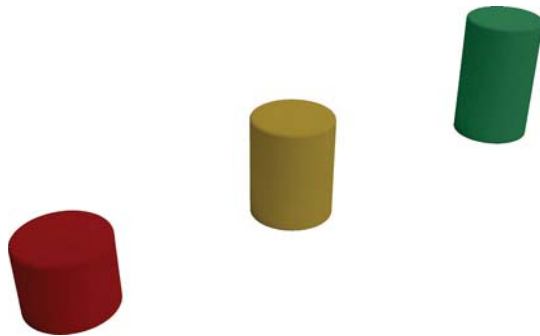

FP4D 0043

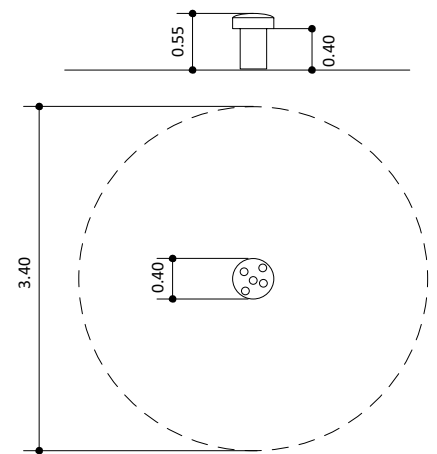

FP4D 0044

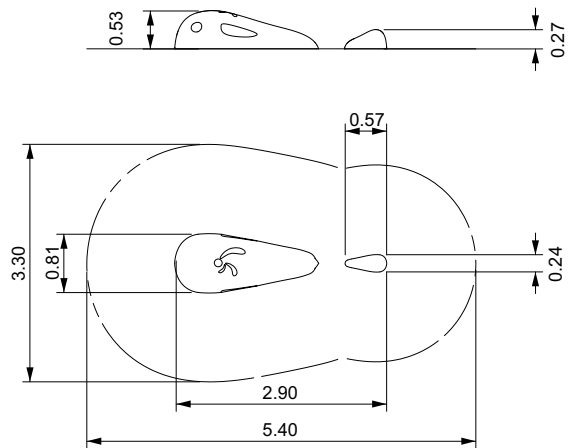

FP4D 0045

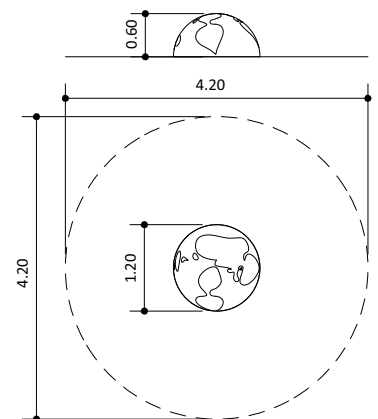





fun
SHOCK
Pavimentazione

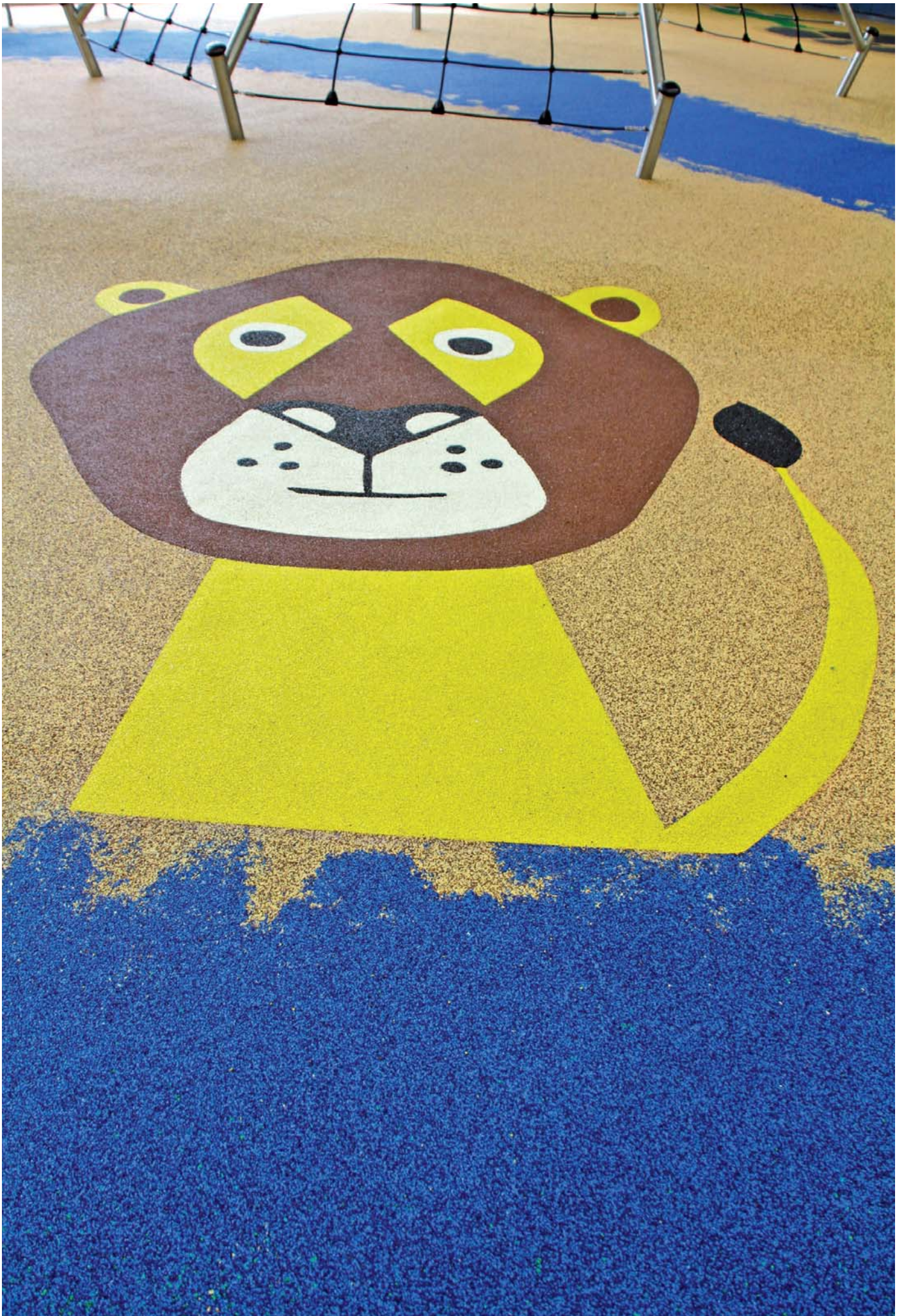

- È una pavimentazione dalle caratteristiche innovative, studiata e sviluppata per rispondere a tutte le esigenze derivate sia dall'applicazione della normativa di sicurezza EN 1177 e alle che ambientale EN71-3 e ISO 14001
- La certificazione ISO 9001 e 14001 garantisce eccellenti standard qualitativi nel rispetto dell'ambiente
- Si adatta perfettamente a tutte le strutture gioco presenti sul mercato
- È resistente ai raggi UV
- It is a flooring with innovative features, designed and developed to meet all the needs of both derived from the application of the safety standard EN 1177 and that the environmental ISO 14001 and EN 71-3
- The certificazione ISO 9001 and 14001 ensures excellent quality standards in respect of the environment
- It fits perfectly to all the gaming facilities on the market
- It is resistant to UV rays



fun
SHOCK
Pavimentazione



FunSHOCK tuttoCOLORE è la pavimentazione antitrauma realizzata con granulo colorato rosso, blu o verde, realizzato in unica soluzione mediante l'utilizzo di granuli di gomma naturale riciclata a granulometria controllata

FunSHOCK allCOLOUR is the anti-shock flooring made of coloured rubber granules in red, blue and green realized in a same solution with controlled particle size of recycled rubber granules



FunSHOCK ARCOBALENO è la pavimentazione antitrauma realizzata con granuli di gomma in EPDM. È la nuova generazione di pavimentazioni di sicurezza per aree e campi gioco.

FunSHOCK RAINBOW is the anti-shock flooring made of EPDM rubber granules. It is the new generation of safety flooring for areas and playgrounds.



FunSHOCK MANO LIBERA è la gamma di disegni colorati e divertenti che consente di personalizzare le pavimentazioni antitrauma e che permette FunSHOCK. Permette di ottenere un prodotto allegroe divertente.

FunSHOCK FREEHAND is the range of colorful and fun designs that allow you to customize the anti-shock flooring and allows FunSHOCK. It allows ottenere a fun allegroe product.



FunBORDER, il cordolo in polietilene colorato, che limitando sia i costi che i tempi di montaggio, si adatta perfettamente a tutte le tipologie di pavimentazioni.

FunBORDER, the curb colored polyethylene, which limit both costs and installation time, is perfectly suited to all types of flooring.



FunSHOCK SOFFICE è la morbida pavimentazione antishock in erba sintetica, che grazie ad una specifica miscela di intasamento, garantisce un'altezza di caduta fino a 210 cm. E' disponibile in vari colori.

FunSHOCK SOFT is the soft shock-absorbing flooring synthetic grass, which utilizes a specific blend of clogging, ensures a drop height of up to 210 cm. It 'available in various colors.



È la pavimentazione di sicurezza interamente realizzata in piastrelle prefabbricate. Ideali per piccole e grandi aree, le piastrelle presentano un nuovo sistema di fissaggio veloce e conveniente.

It is the safety flooring made entirely of prefabricated tiles. Ideal for small and large areas, the tiles are a new fast and conveniente fixing system.



La pavimentazione funSHOCK Sport, si integra al tuo spazio sportivo, rendendolo più bello e colorato.

The flooring funSHOCK Sport, integrates to your sports space, making it more beautiful and colorful.



È la pavimentazione interamente realizzata in granuli di marmo colorato. Ideale per camminamenti e vialetti.

the flooring is made entirely of colored marble granules. Ideal for walkways and drive-ways.

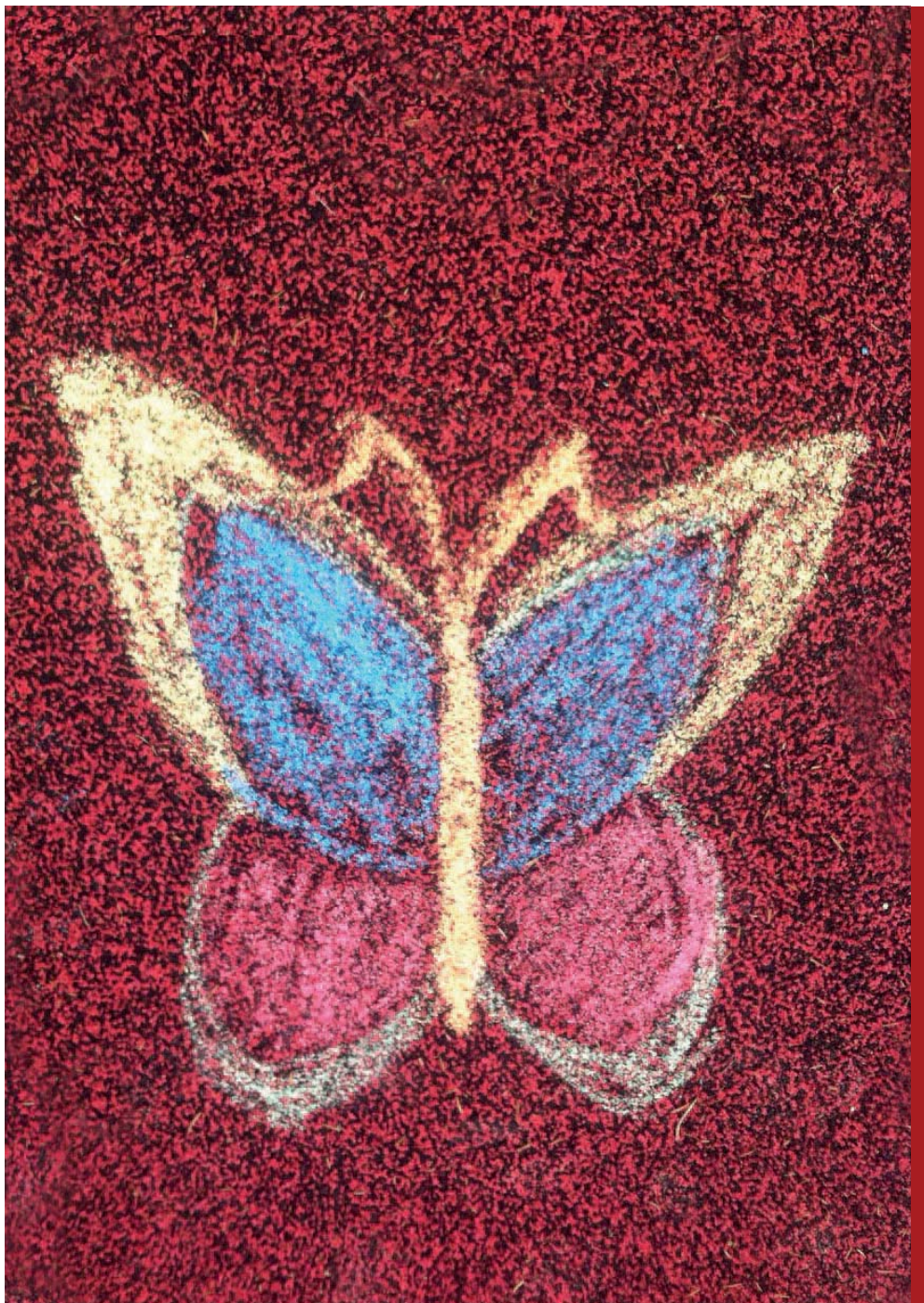

fun
SHOCK
Pavimentazione

Utilizza FunSHOCK per pavimentare il tuo training camp





Dubai - Swiss International Scientific School







Nursery Playground area



Pordenone - Piazza









fun
SHOCK
TILES





fun
SPORT
pavimentazioni





fun
BORDER

FunBorder si installa molto più velocemente dei cordoli tradizionali

Le opere murarie sono ridottissime grazie alla speciale preparazione FunShock Facile

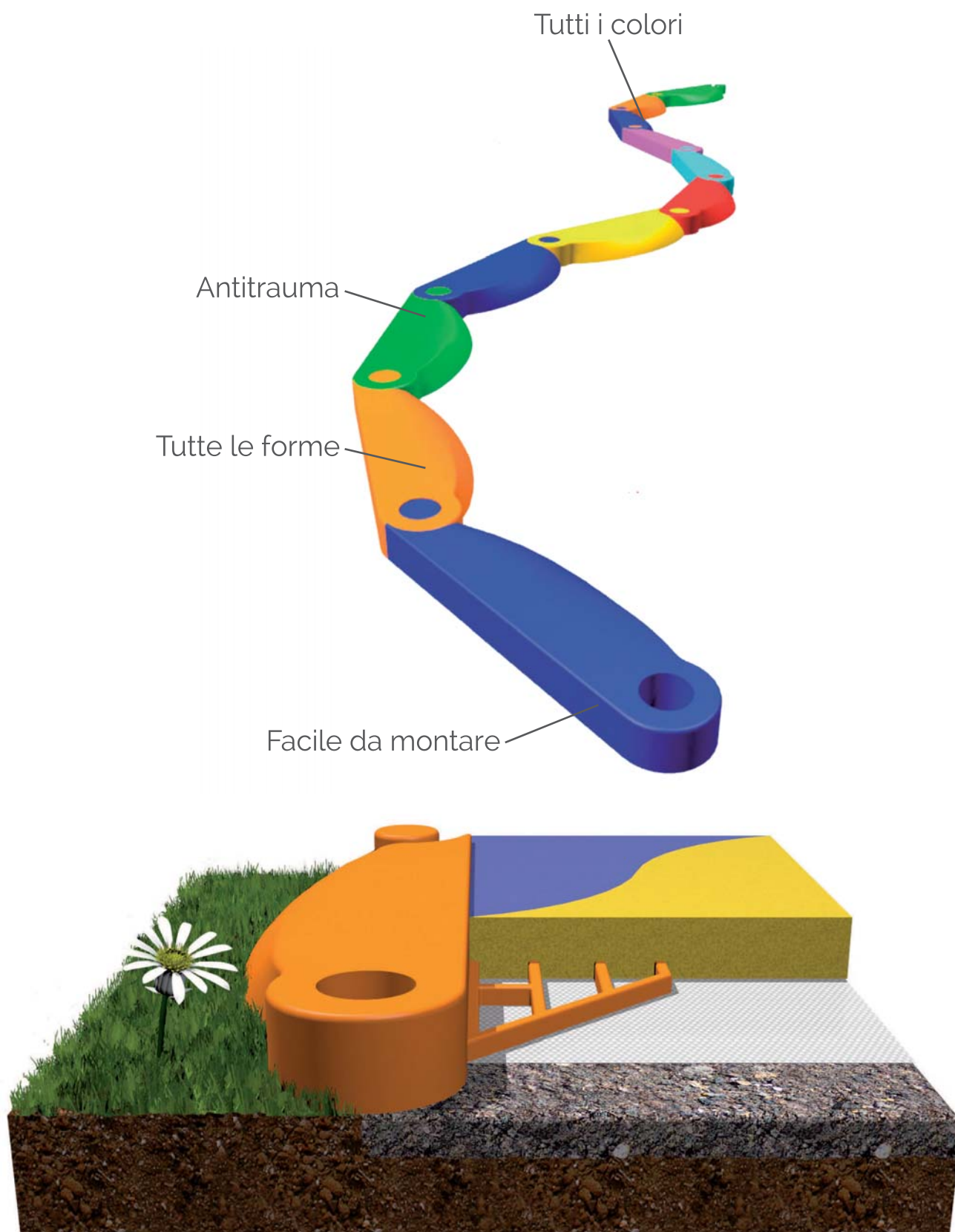







**fun
PLAY
ARREDO**

ARREDO

La Linea FunPlay Arredo,
eleganti e funzionali sono disegnati
per arricchire l'ambiente circostante
creando nuove armonie.

FunPlay furnishings are designed to
create and enrich the surrounding
environment bringing together new
harmonies.







FPR 1001

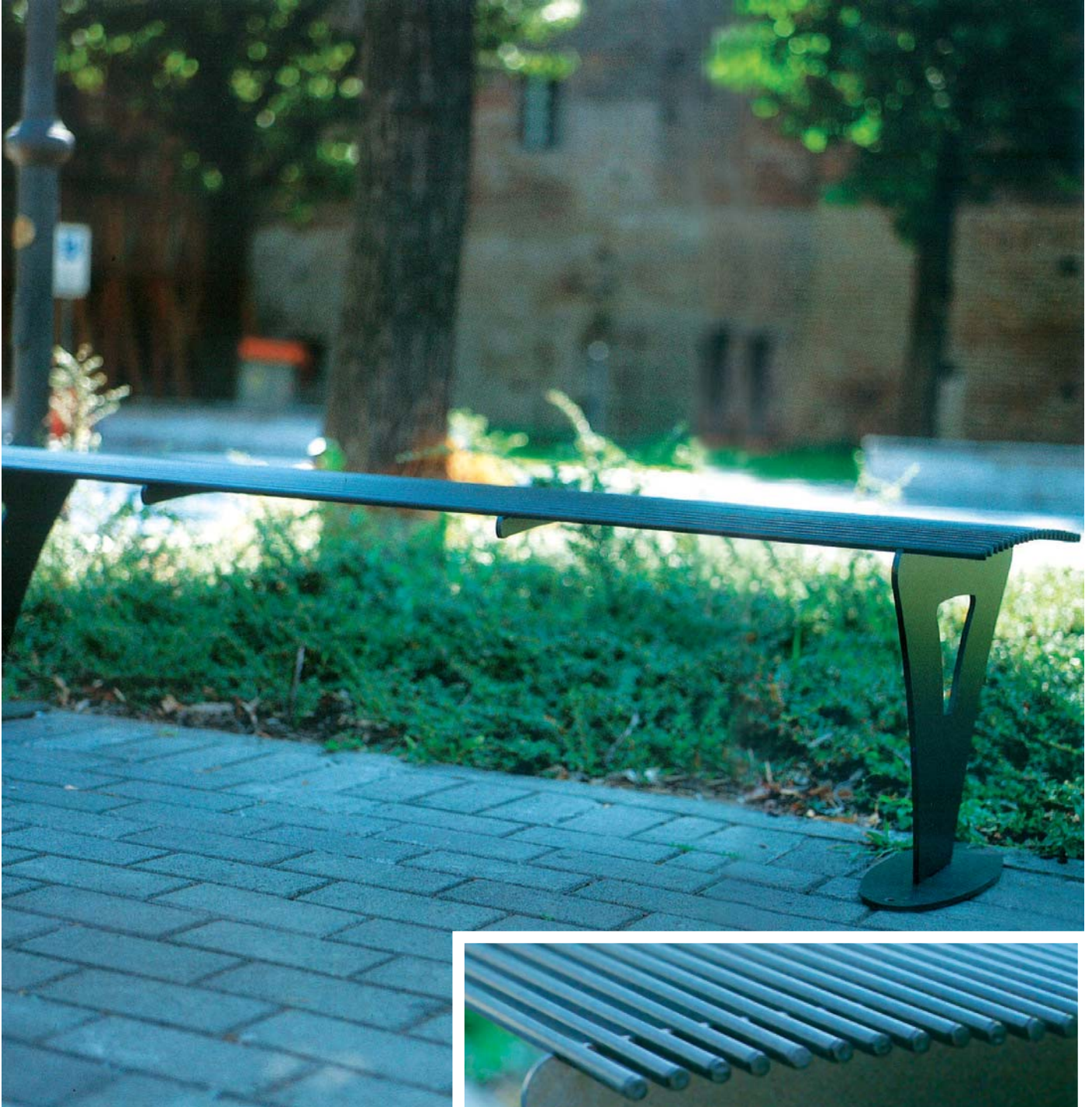

FPR 1002

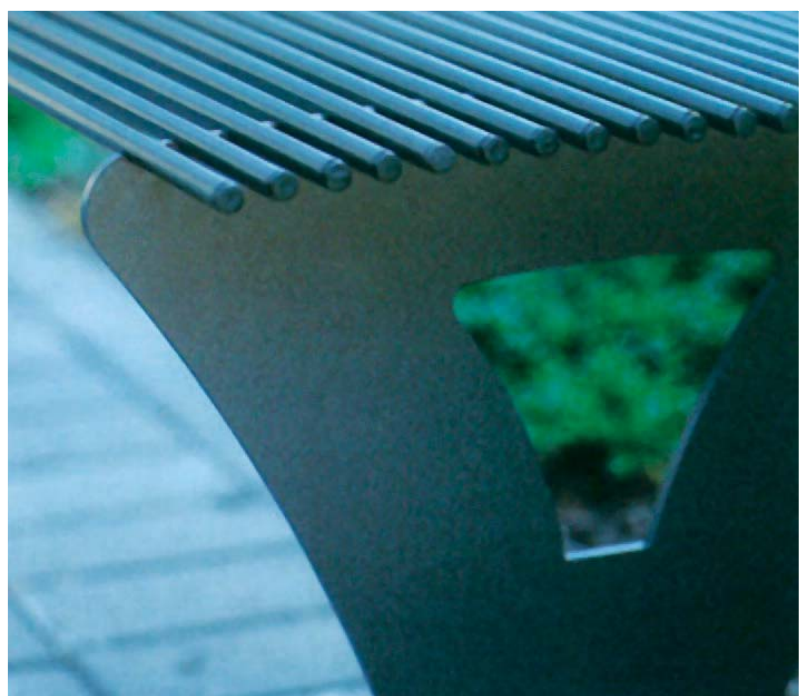

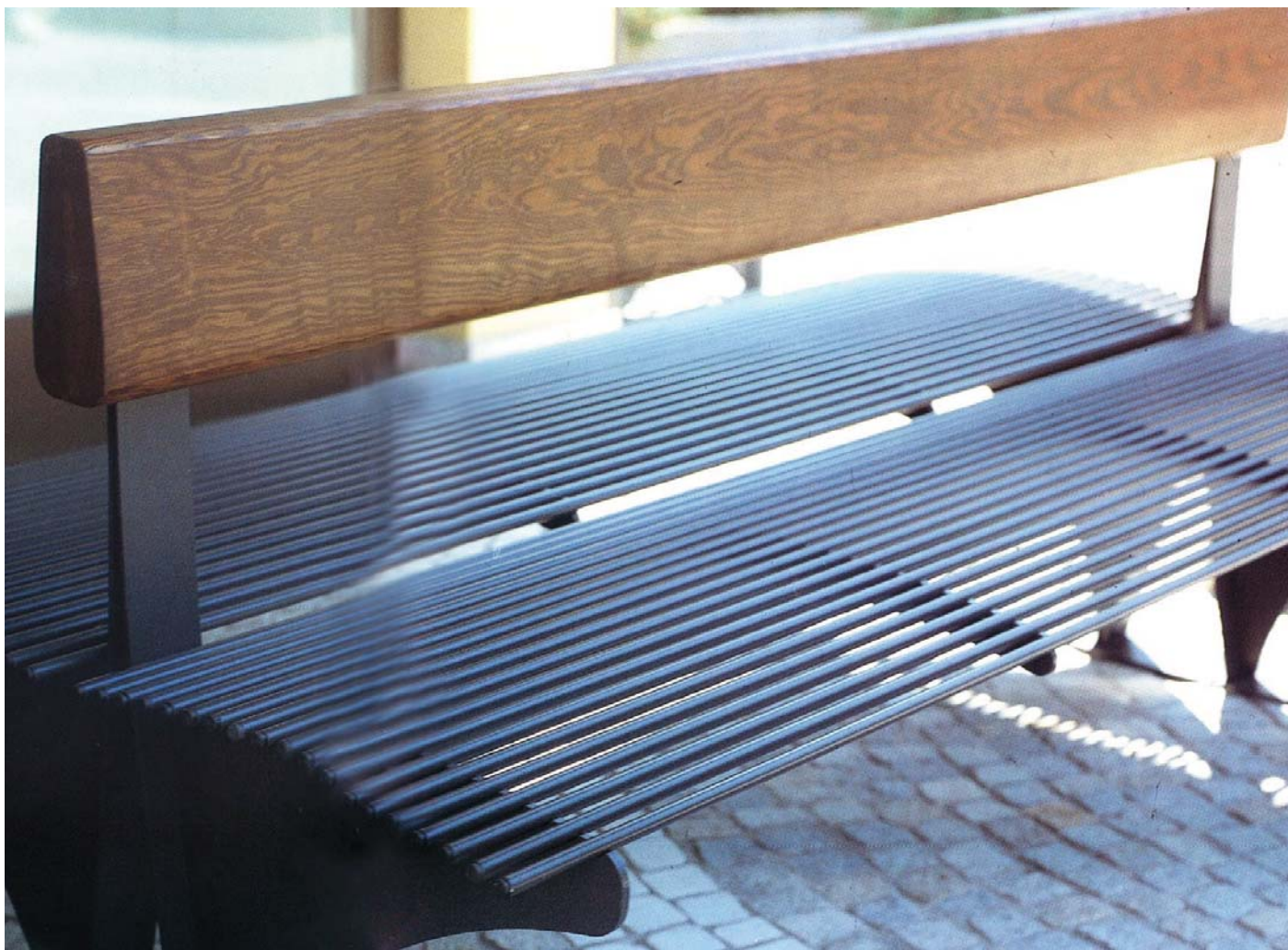

FPR 1003

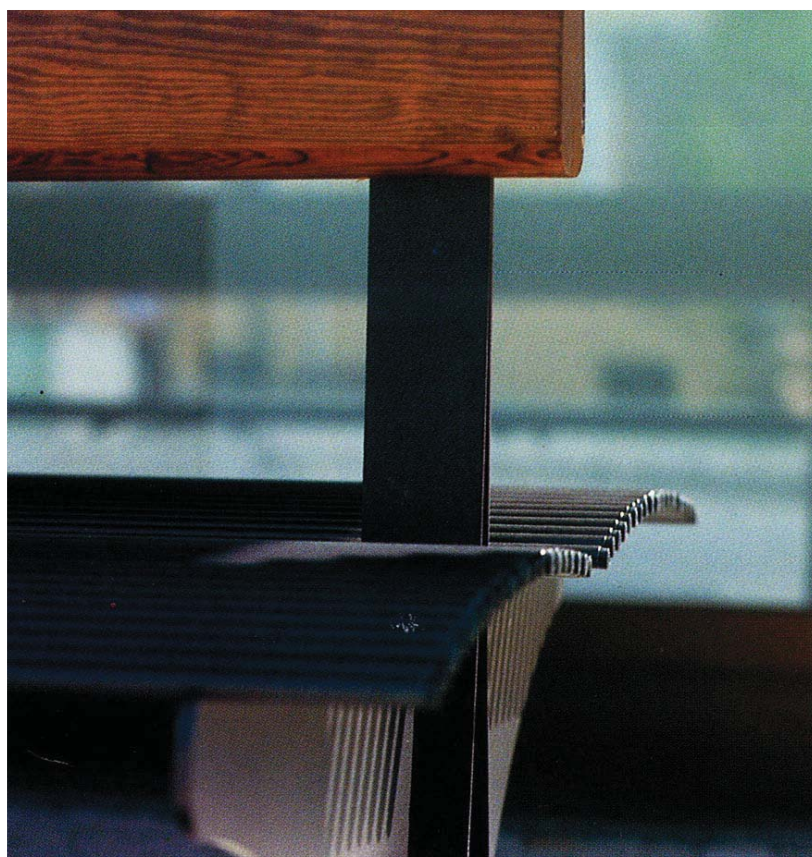



FPR 1004



FPR 1005

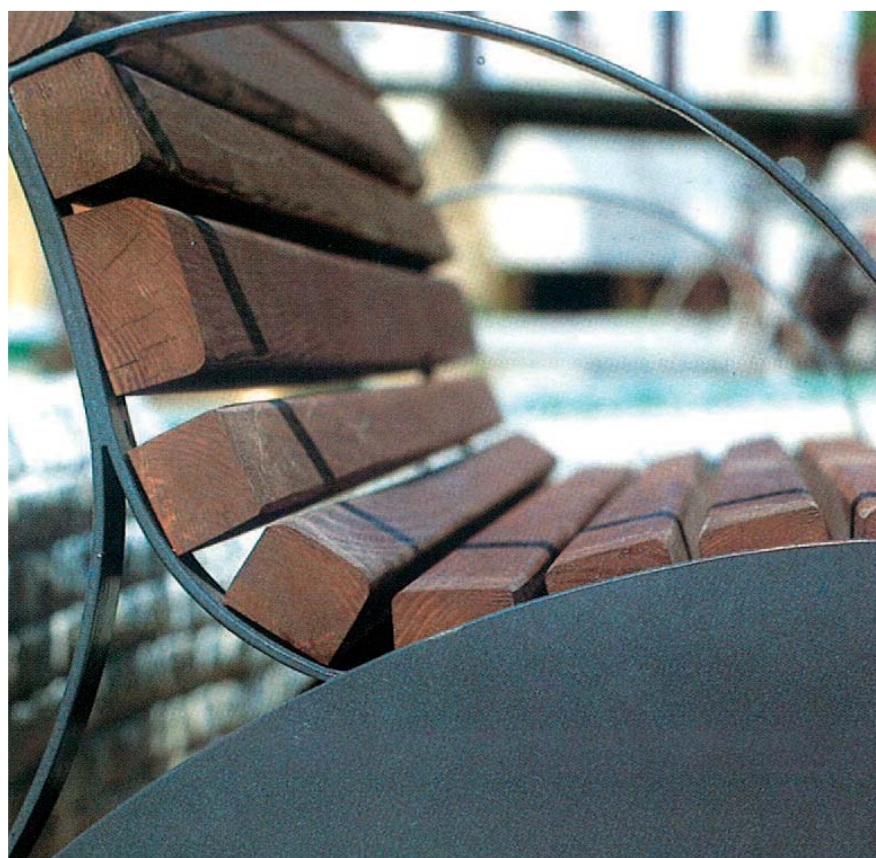



FPR 1006





FPR 1007





FPR 1008



FPR 1009

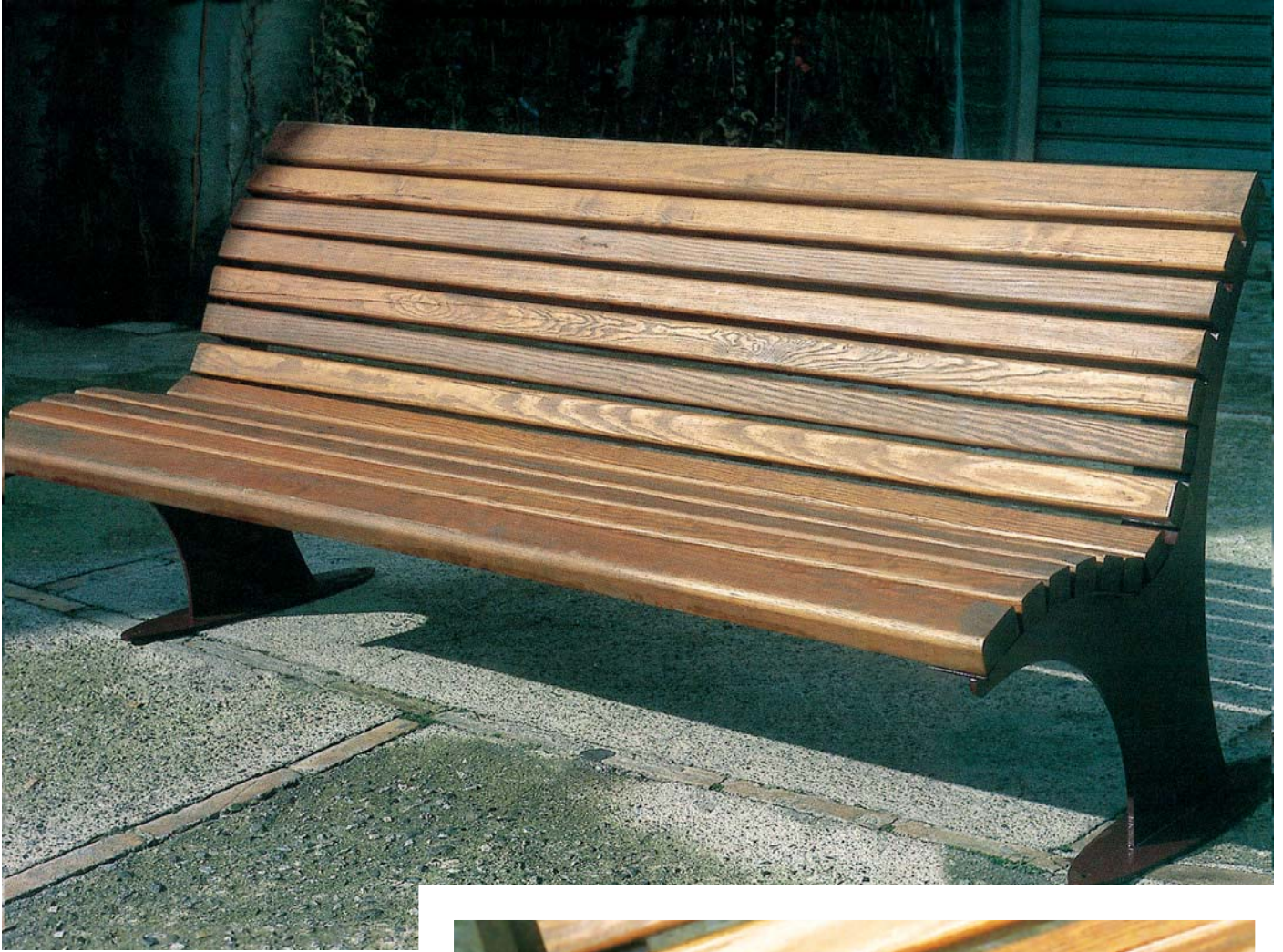

FPR 1010



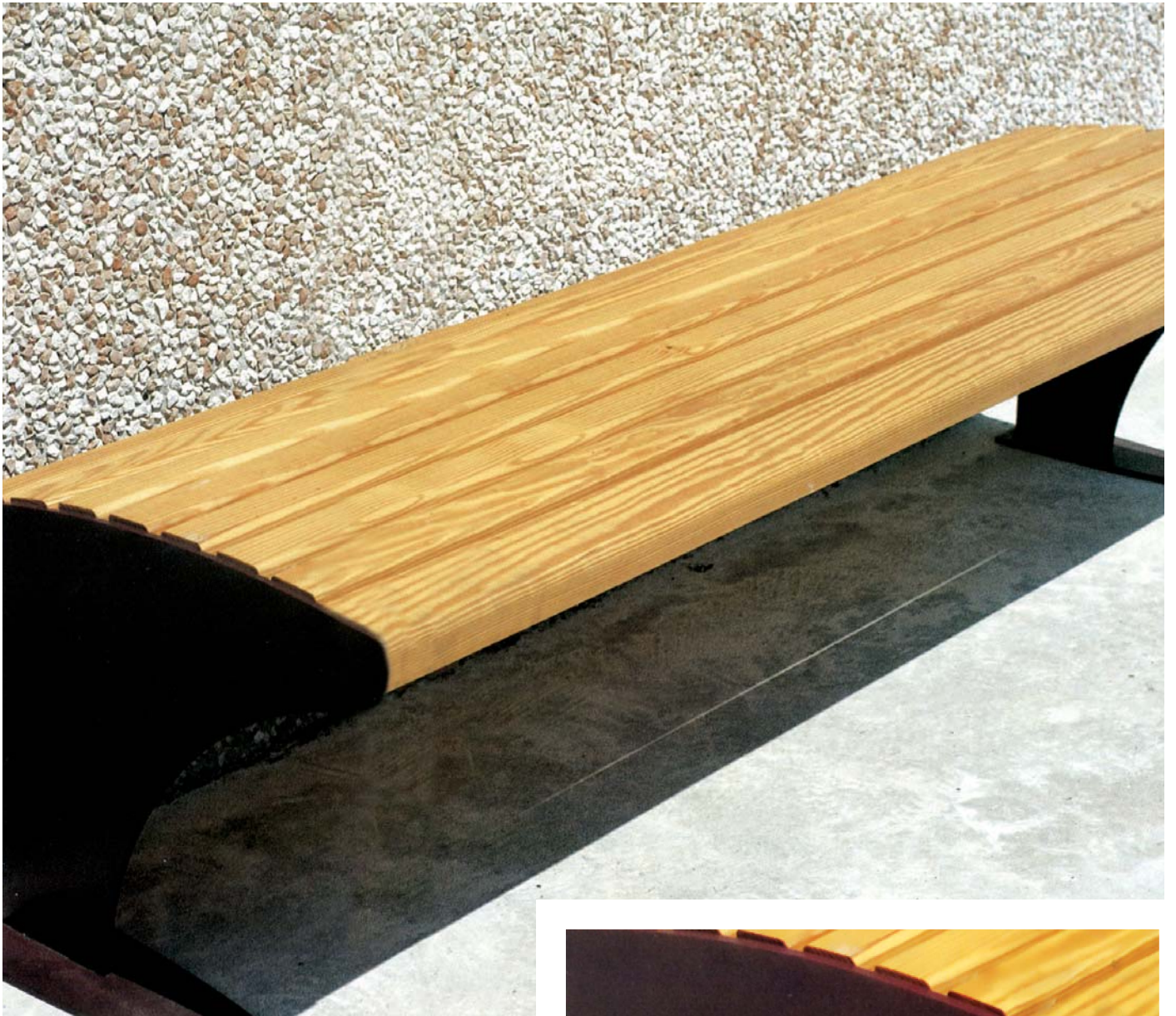

FPR 1011

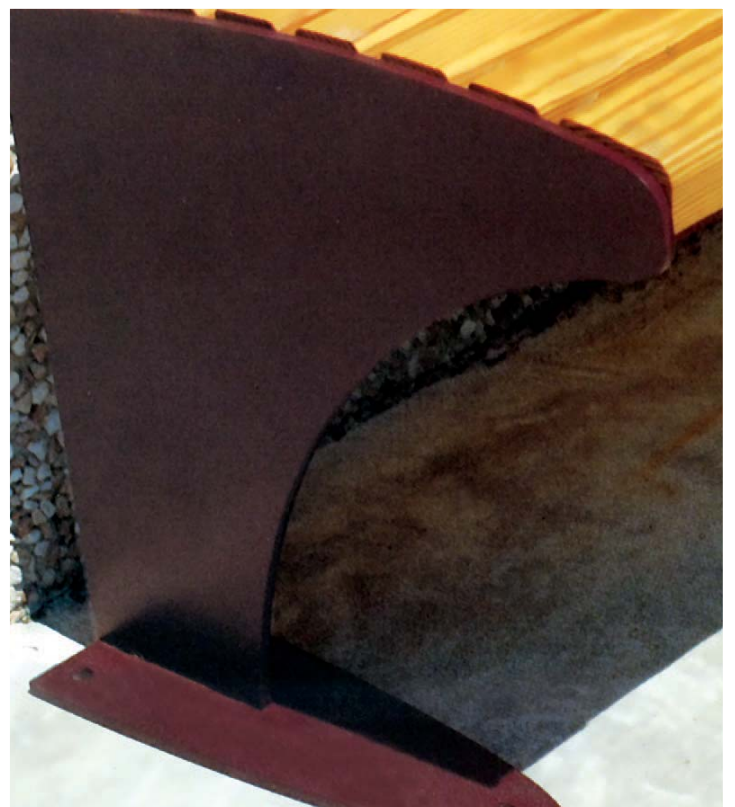



FPR 1012







Cosa prevede la normativa

- Interventi di manutenzione annuali previsti dalla normativa EN 1176/7:2008
- Controllo e serraggio di tutti gli elementi di metallo
- Controllo e serraggio di tutti i collegamenti a vite
- Ingrassaggio delle parti mobili
- Ispezione e controllo di tutti i tipi di funi
- Controllo della conformità di tutti gli elementi di plastica e di gomma
- Controllo delle fondazioni e delle parti strutturali
- Controllo della pavimentazione antitrauma

Cosa offriamo

- Ispezione e intervento delle aree gioco sul territorio
- Creazione di un database consultabile online
- Relazione fotografica e report dello stato attuale delle aree gioco
- Intervento di manutenzione ordinario
- Relazione per attività di manutenzione straordinaria
- Preventivo della manutenzione straordinaria
- Pulizia e igienizzazione delle superfici antitrauma esistenti

What does the legislation

- Annual maintenance interventions envisaged by the EN 1176/7: 2008
- Control and tightening of all elements metallic
- Control and tightening of all the screw connections
- Greasing the moving parts
- Inspection and control of all types of ropes
- Checking the conformity of all plastic and rubber parts
- Control of the foundations and structural parts of pavement
- Control of the antitrauma pavement

What we offer

- Inspection and intervention of the play areas on the territory
- Creating a searchable database online
- Photographic report and status report current play areas
- Ordinary maintenance
- Report for maintenance activities extraordinary the extraordinary maintenance quote
- Cleaning and sanitizing of surfaces existing antitrauma

Funplay Care
*Programma di
manutenzione
delle aree gioco*



*Program maintenance
play areas*



FPGROUP S.r.l.

Via Pietro Micca 78,
20025 Legnano (Mi) – Italia

www.fpgroup-italia.com
commerciale@fpgroup-italia.com

