

LAVINA®



LAVINA® 20N-X-E/20N-X-OE User Manual



SUPERABRASIVE

www.superabrasive.com / factory@superabrasive.com

CE

1. GENERAL INFORMATION.....	5	CHECK EVERY 400 WORKING HOURS.....	15
Machine characteristics.....	5	VACUUM.....	15
Main design.....	5	WATER LEAKS.....	15
Vacuum Connection.....	6	MECHANICAL PARTS.....	15
TECHNICAL DATA.....	6	Electrical System.....	15
CE-Certification.....	6	Lavina® 20N-X-E Electrical.....	16
Vibrations.....	6	schemes with Yaskawa Inverter 380-400 Volt.....	16
NOISE EMISSIONS.....	6	Lavina® 20N-X-OE Electrical.....	17
CUSTOMER SERVICE.....	6	schemes with Yaskawa Inverter 200-240 Volt.....	17
2. SAFETY INSTRUCTIONS.....	6	8.TROUBLESHOOTING.....	18
Recommended Use.....	6	In dex of Problems and Solutions.....	18
Prohibited Use.....	7	8.1 Replacing Power Cord and Plugs.....	18
Preparation for work.....	7	8.2 DISMOUNTING TOOL HOLDER TO CHANGING V-RINGS AND FELT-RINGS.....	18
Protection Devices.....	7	8.3 DISASSEMBLING AND MOUNTING TOOL HOLDER TO CHANGE BUFFERS AND ELASTIC ELEMENT.....	18
Arrest Functions.....	7	8.4 ACCESSING THE PLANETARY BELT.....	20
Safe Use.....	7	8.5 Mounting and tensioning a new planetary belt.....	20
Residual Risks.....	7	8.6 Tensioning used planetary Belt.....	21
Before You Begin.....	7	8.7 Replacing Pulley Units.....	21
OPERATING MACHINE.....	7	8.8 Mounting the belt.....	23
AFTER WORK IS COMPLETED.....	7	8.9 Checking the tension of the belt.....	24
THE WORK AREA.....	7	8.10 Motor Connection.....	24
PERSONAL PROTECTIVE.....	7	When changing the motor, please check the cable connection to your motor.....	24
EQUIPMENT (PPE).....	7	9. WARRANTY AND RETURNS.....	27
OPERATOR.....	8	Warranty Policy for the Lavina® X-E machine.....	27
3. HANDLING AND TRANSPORTATION.....	8	Return Policy for Lavina® X-E machines.....	27
SEPERATING THE CARRIAGE FROM THE MAIN HEAD.....	8	10. DISPOSAL.....	28
Adjusting the handle.....	8	11. MANUFACTURER’S CONTACTS.....	28
STORAGE.....	8	12. SPARE PARTS.....	29
4. OPERATION.....	9	1. LAVINA®20N-X-E General Parts.....	29
Preliminary Controls.....	9	2. LAVINA®20N-X-E Top cover parts 1.....	29
Water Flow Control Unit.....	9	3. LAVINA®20N-X-E Guard parts.....	30
ADJUSTING AND MOUNTING TOOLS.....	9	3.1 LAVINA®20N-X-E GUARD PARTS.....	30
The Control Board.....	9	4. LAVINA®20N-X-E Top cover Parts 3.....	30
Starting the Machine.....	12	5. LAVINA®20N-X-E Bottom cover Parts 1.....	31
Operating the Machine.....	12	6. LAVINA®20N-X-E PLANETARY DRIVE PARTS.....	32
Stopping the Machine.....	12	7. LAVINA®20N-X-E Bottom cover Parts 2.....	32
ALARM.....	12	8.LAVINA®20N-X-E PULLEY UNIT PARTS 2Error! Bookmark not defined.	
5. TOOLS AND ACCESSORIES.....	13	9. LAVINA®20N-X-E Tool Holder Parts /see also fig.8.3.13/ (pos.1 include pos.1.1;1.2;1.3/pos.1.3 include pos.1.3.1 and etc.)	33
Weights.....	13	10. LAVINA®20N-X-E Water TANK Parts.....	33
Tool holder key.....	13	11. LAVINA®20N-X-E/ LAVINA®20N-X-OE CARRIAGE PARTS ..	34
Foam Plate.....	13	12. LAVINA® 20N-X-E CONTROL BOX PARTS 380-400 VOLT...35	
Security plate for Quickchange pads.....	13	LAVINA® 20N-X-OE CONTROL BOX PARTS 200-240 VOLT.....	36
6. POPULAR TOOLS.....	14		
7. MAINTENANCE AND INSPECTION.....	15		
CLEANING.....	15		
CHECK DAILY.....	15		
CHECK AFTER THE FIRST 15 WORKING HOURS.....	15		
CHECK EVERY 200 WORKING HOURS.....	15		

1. GENERAL INFORMATION

This owner's manual is intended for the operator of the LAVINA® X-E machine, the servicing technician as well as anyone else involved with operating or servicing the machine. We recommend that you read the instructions carefully and follow them strictly.

The manual includes information about assembling, using, handling, adjusting and maintaining your LAVINA® X floor grinding and polishing machine.

MANUFACTURER

Superabrasive was founded in 1987, as a manufacturer of high quality diamond tools for the stone and concrete industry. Today, Superabrasive is one of the world's leading companies in the production of diamond tools and floor grinding machinery. At Superabrasive, we strive to deliver the very best solutions to our customers, and enable them to work more efficiently.

GENERAL DESCRIPTION

The LAVINA® X-E machine is intended for grinding, polishing and buffing concrete, marble, granite, limestone and terrazzo surfaces with diamond tools. Additionally, the machine could be used for grinding wood floor surfaces.

The LAVINA® X-E machine is a three-disc machine, which can be used dry as well as wet. For best results, use only tools manufactured or recommended by Superabrasive and its distributors.

⚠ WARNING The LAVINA® X-E machine is manufactured and fitted for the above-mentioned applications only! Every other use may cause risks to the persons involved.

MACHINE CHARACTERISTICS

The LAVINA® X-E machine is made of two main component sections:

MAIN DESIGN

The two main component sections are the carriage and main head.

The **handle** (Fig.1.2) on the frame is adjustable in height and allows the operator to work in a correct and safe working posture.

The **halogen spotlight** (Fig.1.2) enables the operator to work in darker areas.

⚠ WARNING Existing lighting system does not replace adequate overhead lighting.

The **controls** are positioned on top of the electrical box (fig.1.3)

The **electrical box** (fig.1.3) contains the electric switches and the inverter.

The **main feeding cable** is connected with a plug and socket on top.

The **motor feeding cable** is plugged into the socket located on the bottom of the box.

The **tank** is on the opposite side of the frame, so that the weight of the water has no influence on the operation of the machine. The frame weight, on the other hand, is fully absorbed by the driving wheels. An electric pump sprays the water through a front sprayer or internal.

The **motor** is mounted on the base plate and drives the three heads with a belt system.

The **planetary head** is driven by a second belt.

ENVIRONMENTAL CONDITIONS

The temperature range for operating the LAVINA® X-E machine outdoors is between 41°F and 86°F or 5°C and 30°C. Never use the LAVINA® X-E machine during rain or snow when working outdoors. When working indoors, always operate the machine in well-ventilated areas.

ELECTRICAL CONNECTION

The voltage (Volt) and current (Ampere) are displayed on a label on the electrical control box to avoid any incorrect connection. Refer to these before connecting the power. To avoid electrical shocks, make sure the ground power supply is functioning properly.



Figure 1.1



Figure 1.2



Figure 1.3

VACUUM CONNECTION

A connection for a vacuum dust extractor is located on the carriage. The LAVINA® X-E machine does not include a vacuum dust extractor. The customer must purchase the vacuum dust extractor separately. The hose of the vacuum extractor must be Ø 50.8 mm and can be glided over the pipe. The vacuum dust extractor must be adapted for floor grinders and have a minimum air displacement of 320m³/h with a negative vacuum of 21 kPa.

TECHNICAL DATA

	Lavina® 20N-X-E		Lavina® 20N-X-OE	
Voltage/Hz	3 ph x 380-400V 50-60Hz		1 ph x 200-240V 50-60Hz	
Amperage	Max 15 Amps		Max 15 Amps	
Power	5,5 kW	7,5 HP	5,5 kW	7,5 HP
Tool holder rpm	300-1100 rpm		300-1100 rpm	
Working width	510 mm	20"	510 mm	20"
Tool diameter (QC Plate)	3x 225 mm	3x 9"	3x 225 mm	3x 9"
Weight	172 kg	380 lbs	172 kg	380 lbs
Grinding pressure	91 kg	200 lbs	91 kg	200 lbs
Additional weight	max 2x 22 kg	max 2x 48 lbs	max 2x 22 kg	max 2x 48 lbs
Application	wet and dry		wet and dry	
Vacuum hose port	Yes		Yes	
Water tank capacity	20 l	5.2 gal	20 l	5.2 gal
Water feed	with pump (peripheral and front)		with pump (peripheral and front)	
Cable length	17.4 m	57 ft	17.4 m	57 ft
Machine LxWxH	1350x540x1100 mm	53.1"x21.3"x43.3"	1350x540x1100 mm	53.1"x21.3"x43.3"
Packing LxWxH	1150x730x1155 mm	45.2"x28.7"x45.5"	1150x730x1155 mm	45.2"x28.7"x45.5"

CE-CERTIFICATION

The Lavina® X-E machine is designed to operate correctly in an electromagnetic atmosphere of industrial type and is equipped with all the mechanical and electrical safety protections in conformity with the following European CEE rules and regulations: The Lavina® X-E machine complies with the Safety Directive for machines 2006/42/EC, the EMC Directive 2004/108/EC and the Low Voltage Directive 2006/95/EC.

Also complies with the norms in use BDS EN ISO 12100, BDS EN 13862, BDS EN ISO 13857, BDS EN 349, BDS EN ISO 13850, BDS EN 13732-1, BDS EN 953, BDS EN ISO 13849-1, BDS EN 1037, BDS EN ISO 5349-1, BDS EN ISO 11201, BDS EN ISO 3744, BDS EN 1033:2002, BDS EN 60204-1, BDS EN 1837, BDS EN 61000-6-4, BDS EN 61000-6-2, BDS EN 61000-4-2, BDS EN 61000-4-4, BDS EN 61000-4-5, BDS EN 61000-4-11, BDS EN 55016-2-1

Test results are a part of the machine's technical information and can be sent upon a special request. The machine is delivered with the CE mark exposed and provided with a EC declaration of conformity.

VIBRATIONS

The measured vibration value on the surface of gripping in case of guiding the machine is $a_{hw}=2,95m/s^2$. The measurement is made in accordance with the BDS EN ISO 1033 and BDS EN ISO 5349-1.

NOISE EMISSIONS

The maximum noise level at distance of the machine of 1m in case of working at idle does not exceed 70 db(a). The measurement is made in accordance with the BDS EN ISO 11201 and BDS EN ISO 3744.

LABEL DATA

The data on the label provides the correct Voltage and kW (needed for operational purposes); Weight (needed for transportation purposes); production year and serial number (needed for maintenance purposes).

CUSTOMER SERVICE

For customer assistance and technical support contact your local distributor or contact the producer Superabrasive Ltd. or visit us at www.superabrasive.com, where you can download a copy of this manual.

2. SAFETY INSTRUCTIONS**RECOMMENDED USE**

The LAVINA® X-E machine is designed and manufactured to



grind and polish concrete, terrazzo, and natural stone floors. It can be used for renovations as well as for polishing. The machine is

Superabrasive User Manual Original Language
designed for dry or wet use. When using it dry, use a vacuum of appropriate size. For more information, please refer to the chapter on handling the vacuum connection.

Lavina® 20N-X-E/ Lavina® 20N-X-OE

8/2018

NOTE: In order to reduce any consequences of the above-mentioned risks, we advise that machine operators follow the instructions in the manual at all times.

WARNING

PROHIBITED USE

The machine MUST NOT be used:

For applications different from the ones stated in the General Description chapter.

For not-suitable materials.

In environments which:

- Possess risks of explosion
- Possess high concentration of powders or oil substances in the air
- Possess risks of fire
- Feature inclement conditions.
- Possess electromagnetic radiation.

PREPARATION FOR WORK

Make sure that

You have closed the work area, so that no person unfamiliar with operating the machine can enter the area.

The tool plate and tools are adjusted to the machine properly.

There are no missing parts of the machine.

The machine is in upright working position.

The protection devices are working properly.

The electrical cable is free to follow the machine easily. In order to keep the electrical cable from being damaged, no vehicle should cross the zone where electrical cables are situated.

WARNING

PROTECTION DEVICES

The machine is equipped with several protection devices including the following:

An emergency stop button

A protection skirt and hood for protecting the tool plates.

These devices protect the operator and/or other persons from potential injuries. Do not remove them. On country, before using the machine, please ensure that all protection devices are mounted and function properly. The Security plate prevents the QuickChange pads from loosening during use.

WARNING

ARREST FUNCTIONS

Methods of arresting the machine are the following:

Button to stop the motor (category 1)

Emergency stop button (category 1)

WARNING

SAFE USE

The LAVINA® X is designed to minimize all risks correlated with its use. However, it is not possible to fully eliminate the risks of an accident with the machine. An unskilled or uninstructed operator may cause correlated residual risks. Such risks are:

Position Risks due to operator's incorrect working position

Entanglement Risks due to wearing inappropriate working clothes

Training Risks due to lack of operational training

WARNING

RESIDUAL RISKS

During the normal operating and maintenance cycles, the operator is exposed to few residual risks, which cannot be eliminated due to the nature of the operations.

WARNING

BEFORE YOU BEGIN

Working area must be clear from any debris or objects.

A first-time operator must always read the manual and pay attention to all safety instructions.

All electric connections and cables must be inspected for potential damages.

Ground wire system of the power supply must be also inspected.

Perform general daily inspections of the machine and inspect the machine before each use.

Always inspect the safety devices: Mount the Security plate for the Quickchange pads.

The emergency break must be clear and working

The tool protector must be working

The machine must be clean

Never operate the machine in the rain!

Confirm that there are no missing parts especially after transportation, repair, or maintenance.

Before filling the water tank with water make sure the machine is not working and the main switch is turned off.

Before turning on the machine make sure that the base is placed on the floor, the machine MUST NOT be in an upright position when turned on!

WARNING

WARNING

OPERATING MACHINE

When operating the LAVINA® X, make certain that there is no one, but you around the machine.

Never leave the machine unattended while working.

The electrical cable must move freely and must be damage-free.

The water hose must move freely and must be damage-free.

Check the floor you will work on to make sure it is not too uneven. If this is the case, it may damage the machine.

AFTER WORK IS COMPLETED

Clean the machine and its surroundings properly

Empty and clean the water tank

Unplug the machine and wind up the electrical cable

Store the machine in a safe place

WARNING

THE WORK AREA

Make certain that people or vehicles do not enter the work area.

Clear paths of hoses or cables.

Always check the floor for debris

WARNING

PERSONAL PROTECTIVE EQUIPMENT (PPE)

Always wear safety shoes when working with the machine.

Always wear ear protectors when working with the machine.

All personnel in the immediate work area must wear safety glasses with side shields.

WARNING

Always wear safety gloves when changing the tools.
Always wear clothes suitable for the work environment.

OPERATOR

The operator must know the machine’s work environment. Only one operator at a time can work with the machine. The operator must be properly trained and well instructed prior operating the machine.

The operator must understand all the instructions in this manual.

The operator must understand and be able to interpret all the drawings and designs in manual.

The operator must know all sanitation and safety regulations pertaining to the operation of the machine.

The operator must have floor grinding experience.

The operator must know what to do in case of emergency.

The operator must have an adequate technical knowledge and preparation.



3. HANDLING AND TRANSPORTATION

SEPERATING THE CARRIAGE FROM THE MAIN HEAD



Figure 3.1



Figure 3.2



Figure 3.3

Unplug the motor cable plug from the control box (Fig. 3.1) and disconnect the water hose from the main head by pulling it out (Fig. 3.2). Wind the electrical cable on the carriage. Release the pin sets (Fig. 3.3) which attach the head to the carriage.

Pull out the vacuum hoses, and dismount the head from the carriage (Fig. 3.4).

The head of the LAVINA® X-E machine has one bar and a support which can be used as handles for easy moving and transportation (Fig. 3.4). The LAVINA® X-E machine is engineered with easy transportation in mind. The ability to dismantle the machine in two parts allows for convenient transportation and storage (Fig.3.4, Fig.3.5).



Figure 3.4



Figure 3.5

ADJUSTING THE HANDLE

The Handle on the frame is adjustable in height and allows the operator to work in a correct and safe posture.

TO ADJUST, SIMPLY PULL THE LOCKING PIN (FIG.3.6) AND MOVE THE FRAME. A LOADED SPRING WILL RETURN THE PIN AND LOCK THE FRAME IN ANY OF SEVERAL POSITIONS (FIG.3.7). CHOOSE THE VERTICAL POSITION TO EASILY MOVE THE MACHINE.

STORAGE

Always store and transport the LAVINA® X-E machine in a dry place. Never transport the LAVINA® X-E machine unprotected; it may be damaged if transported unprotected during rain or snow.



Figure 3.6

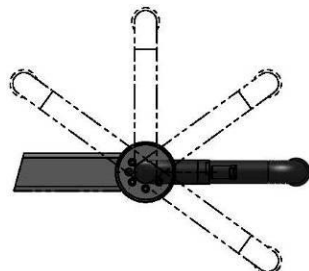

Figure 3.7



When, during storage of the machine, the temperature may fall to 32° F (or 0° C) or less, water should be emptied from the system using the following steps:

- Pull out the hose from the tank (Fig.3.8)

- Using compressed air, blow out excess water from the system at each position of the valve (Fig. 3.9, Fig. 3.10)



Figure 3.8



Figure 3.9



Figure 3.10

4. OPERATION

PRELIMINARY CONTROLS

Inspect the working area as explained in the safety instructions. For wet use, fill the water tank with the electrical cable disconnected. Connect the vacuum extractor and ensure that the vacuum hose is clear and will easily follow the machine. Plug in the machine and make sure that the power cord is free to follow the working direction of the Lavina® X-E machine.

WATER FLOW CONTROL UNIT

The operator can direct water to be sprayed in the front (Fig.4.1) by positioning the lever in the horizontal position; the water will spray under the cover of the machine when the lever is in the vertical position (Fig.4.2). The flow regulating valve located on the tank (Fig.4.3) controls the water flow to the working area – in front of the machine or under the main head cover of the machine.



Figure 4.1



Figure 4.2



Figure 4.3

ADJUSTING AND MOUNTING TOOLS

The Holder A41 in LAVINA® X can work with either 3 or 6 buffers, which will alter its range of motion. You can make the change after dismantling the holder as per the instructions in TROUBLESHOOTING.

In the Lavina 20-X, the holder is initially mounted with 3 buffers.

Mount the tools only after ensuring that there is enough diamond bond material left. Be sure that the plates are always clean before mounting.

WARNING: Always secure the “Quickchange” pads with the security plate

(Fig.4.4), and lock with the tool holder key (Fig.4.5). Diamond tools with Velcro are attached on three 9inch foam plates. The foam

plates are mounted on the key lock (butterfly). Always use the tool holder key (Fig.5.3).

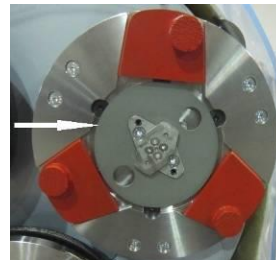

Figure 4.4



Figure 4.5



Figure 4.6

THE CONTROL BOARD

1. Power cable plug

2. Digital Tachometer Indicates the revolution per minute of the grinding plates (not the revolution per minute of the entire unit).

3. Lamp cable gland

4. Reset button resets the alarm of the inverter. **Button** lights blue when the inverter goes into alarm mode.

5. Water pump switch Lights orange when the water pump is working.

6. Power led lights green when the power is on

7.Forward/Reverse switch Select forward for clockwise rotation of the grinding plates or reverse for counterclockwise rotation of the grinding plates (Recommended configuration). The preferred

operating direction should be when the switch is in the forward position. The proper direction of rotation of the motor (counterclockwise) is indicated by an arrow on its cover.

8.Potentiometer controls the RPM of the grinding plates on a range of 300-1100 rpm

9. READY OFF / ON switch. Switching to ON puts the machine in standby mode. The switch lights to indicate this.

Switching to OFF takes the machine out of standby. The light extinguishes to indicate this.

The switch returns to its starting position after being released.

10.STOP button stops the motor

11. RUN button starts the motor

12.Emergency button stops the motor in case of emergency

STARTING THE MACHINE

First, follow the directions in the chapter on Safety Devices and Safety Instructions. Next, release the emergency stop (12), turn the **Ready** switch (Fig. 4.6 9) to the ON position to put the machine in standby mode. Check the potentiometer (8), and ensure that it is set to the working speed. If working wet, add water to the floor surface. If working dry instead switch on the vacuum unit. Finally, hold the machine firmly and push the RUN button (11).

OPERATING THE MACHINE

GUIDE THE MACHINE IN STRAIGHT LINES ACROSS THE FLOOR, SLIGHTLY OVERLAPPING THE PREVIOUSLY COMPLETED SURFACE WITH EACH NEW LINE. WORK AT A CONSTANT SPEED, ALLOWING THE TOOLS TIME TO WORK AT A SPEED APPROPRIATE FOR THE TOOLS' GRIT SIZE. AVOID VIBRATIONS. DO NOT STOP THE MACHINE WHILE TOOLS ARE STILL RUNNING AS THEY WILL MARK THE SURFACE OF THE FLOOR. WHEN WORKING WET, SELECT THE DESTINATION OF THE WATER FEED WITH THE WATER TAP (FIG. 4.2-1) AND PERIODICALLY RUN THE PUMP (FIG. 4.10-11) TO RELEASE WATER ONTO THE FLOOR SURFACE. STARTING THE PUMP IS POSSIBLE ONLY IF THE MACHINE MOTOR IS ON. WHEN WORKING DRY, CHECK THE FLOOR SURFACE PERIODICALLY FOR DUST ACCUMULATION. CHECK REGULARLY TO SEE IF YOUR VACUUM WORKS PROPERLY

STOPPING THE MACHINE

The stopping of the machine must be done gradually until the motor stops. Do not stop moving the machine before the motor comes to rest, as the tools could damage the surface.

To stop the machine:

1.Push the STOP button (10) .

2.Turn the **ON/OFF** (9) switch in position OFF, this will cut the voltage to the inverter and the green light will turn off.

While working do not turn off directly from the READY switch or from the Emergency Stop, but follow the steps above.

WARNING

Use the Emergency button (12) only in emergency.

Remember not to hold the machine in one spot before turning off the motor.

ALARM

The Reset button (4) will light when the inverter goes into alarm mode. The most common failure is motor overload. To exit alarm mode, push the reset button (4). A code on the inverter's display indicates the type of the alarm. **When the same alarm is repeated several times, it is imperative to find and eliminate the cause of it, otherwise the inverter can become damaged.**

5. TOOLS AND ACCESSORIES

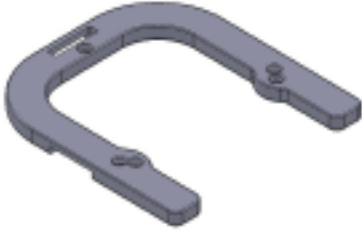

Figure 5.1

WEIGHTS

Superabrasive offers additional weights used to increase the productivity of the machine (Fig.5.1). Each additional weight weighs about 64 lbs or 29kg. Each individual application, type and condition of surface, power capacity of the outlet, etc. will determine the number of weights you can use without tripping a breaker. The weights stack onto three posts fixed around the outer bowl (Fig.5.2). Additional weights will largely depend on the tools; it is not always possible to add weights. Some tools work too aggressively and will cause the machine to stop. The weight can be ordered with item number A08.00.00.00



Figure 5.2

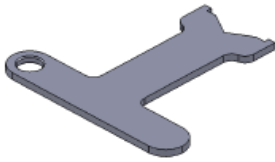

Figure 5.3

TOOL HOLDER KEY

The tool holder key (Fig.5.3) is used for adjusting, mounting and dismounting of the foam plates. Always use the key to properly secure foam plates. Item number is A03.00.00.00

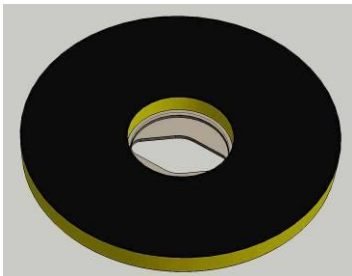

Figure 5.4

FOAM PLATE

Diamond tools with Velcro are mounted on the foam plate 9"(Fig.5.4). The foam plate is mounted on the "QuickChange" System. Item number is LV-9-FP-S

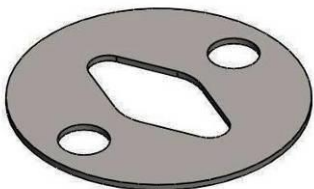

Figure 5.5

SECURITY PLATE FOR QUICKCHANGE PADS

Plate (Fig.5.5) used to secure the "QuickChange" pads. Item number is A38.00.01

6. POPULAR TOOLS

RECOMMENDED TOOLS



QuickChange System and Tooling feature extremely fast and convenient tool changes, and a long tool life, providing for great long-term cost savings. The QuickChange pads are produced in four different bonds for super hard, hard, medium and soft concrete, in a variety of grit sizes. They are offered with 1 or 2 buttons or rectangular segments, which allows you to customize the aggressiveness of the cut.



Calibra grinding discs: our popular ceramic bond discs are designed for the removal of difficult scratches and they save you valuable time by eliminating the need for multiple passes with metal tools. They can be used wet or dry, and are best for hard concrete applications. They are 3-inch, with included Velcro back attachment.



NATO® polishing discs feature a special resin formula designed for both wet and dry applications and a unique design with wide channels allowing for work on a cleaner surface and ensuring a quality polish. Available in 3 and 4 in sizes. They are with Velcro attachment.



V-HARR® Premium Polishing Pads are designed for mechanically polishing and restoring concrete; also ideal for terrazzo and hard stone floors. V-HARR® pads are offered in a wide variety of diameters and grit sizes to accommodate many applications. Dry use is strongly recommended.



Shine Pro® are high quality diamond-integrated pads for floor maintenance. Available in a variety of sizes, they are great for daily use. When used wet, they require only water (no wax or chemicals needed), making them a very environmentally-friendly solution for maintaining floors.

Use Only Superabrasive's Recommended Tools. For More Tooling Options, Visit www.superabrasi

7. MAINTENANCE AND INSPECTION

CLEANING

Keep your machine clean. Cleaning the machine on a regular basis will help detect and solve potential problems before they cause damage to the machine. Most importantly, check and clean the tool plate connections, power cord and plugs, vacuum hoses and water tank.

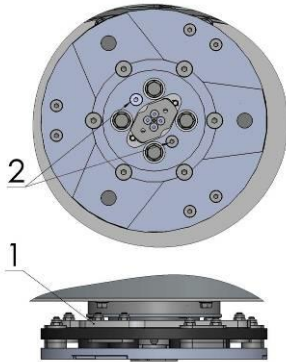

Figure 7.1

clean.

CHECK AFTER THE FIRST 15 WORKING HOURS

Check the belt tension after 15 hours of working with the machine. The bottom cover has a control cover (Fig. 7.2) that allows fast and easy control and correction of the belt. It is recommended to check the tension of the belt after the first 15 hours and to tighten if necessary. For the correct tension, see TROUBLESHOOTING "mounting the belt". Every time you open the control cover, be sure to replace ALL screws.

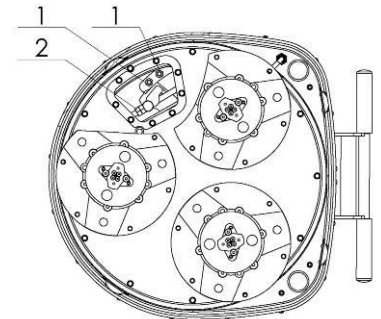

Figure 7.2

CHECK EVERY 200 WORKING HOURS

Every 200 working hours, the operator should inspect all parts of the machine carefully. Most importantly, inspect and clean the tool plate connections, power cord and plugs, vacuum hoses, and water tank, and filter. Also, check the water flow of the pump. Check the guard assembly. Make certain the wheels are clean and rotate properly. Inspect the control buttons. If there are defective control parts, they should be replaced immediately. Replace worn vacuum- and water hoses. Check the tension of the belt and tighten if necessary. For the correct tension, see TROUBLESHOOTING.

Dismount the tool holders (See Troubleshooting), replace all parts (elastic element, buffers, sealers) with the slightest damage or consume.

Open the inspection cover on the motor base to check the planetary driving belt, by moving the main head the belt should not slip on the planetary (central) pulley .

CHECK EVERY 400 WORKING HOURS

In addition to checks made every 200 working hours, replace sealer and V-rings as described in chapter "TROUBLESHOOTING REPLACING BELT AND PULLEY UNITS". Check if belts and bearings are in good condition, change if needed.

VACUUM

As stated previously, frequently check hoses and other parts for clogging.

WATER LEAKS

Replace any leaking parts immediately as the water could damage your machine

MECHANICAL PARTS

Parts such as the belts, seal rings/ felt ring and V-rings/, elastic element and buffers and guard assembly are subject to wear and should be replaced as needed.

ELECTRICAL SYSTEM

Dust should not enter the control box, as it will destroy the contacts. Remove (blow out) any dust present.

**LAVINA® 20N-X-E ELECTRICAL
SCHEMES WITH YASKAWA INVERTER 380-400 VOLT**

380-400 Volt

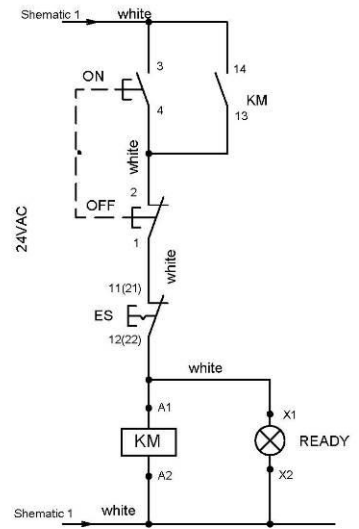
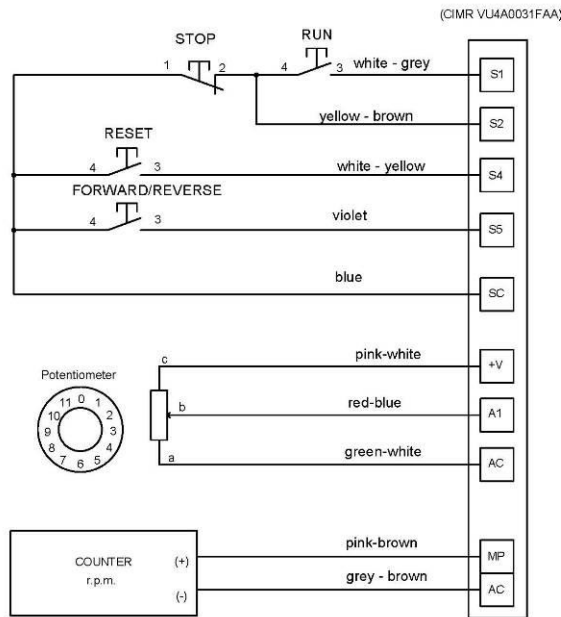
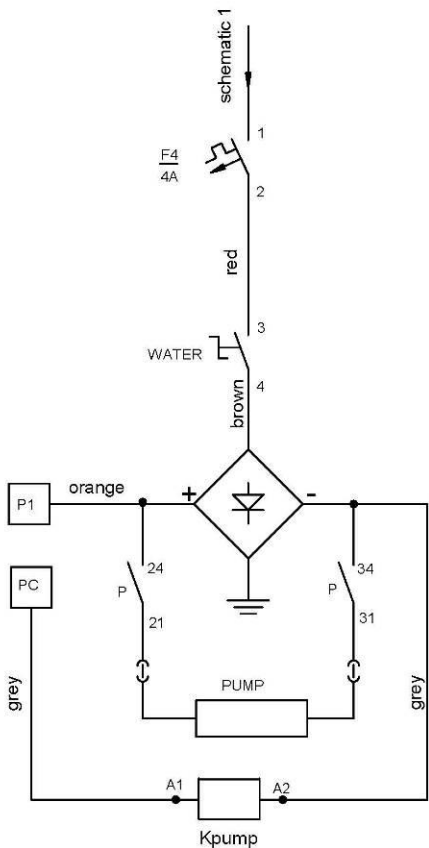
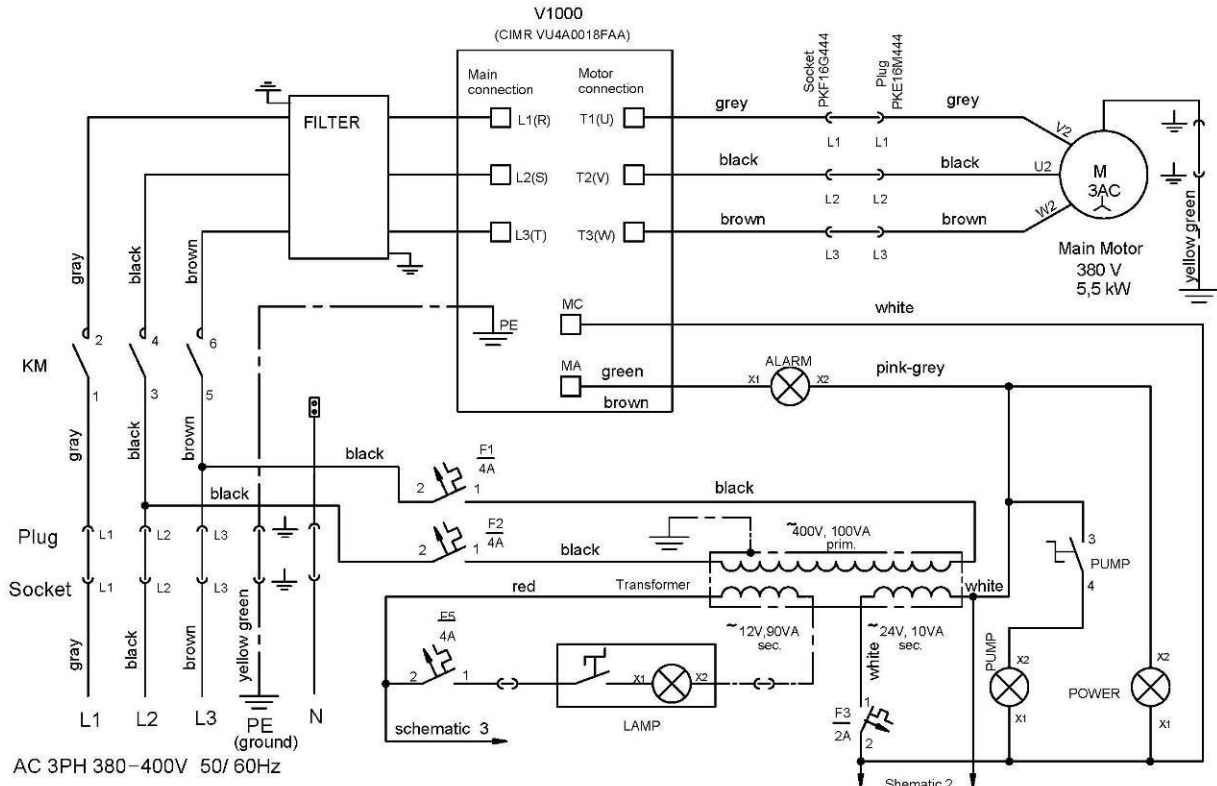

The motor is connected in "Star" 380Volt, reminder for the wire connection of the motor.

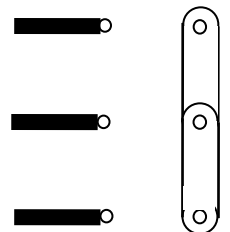

**LAVINA® 20N-X-OE ELECTRICAL
SCHEMES WITH YASKAWA INVERTER 200-240 VOLT**

200-240 Volt

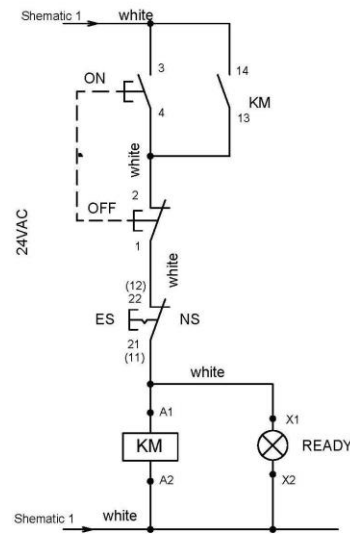
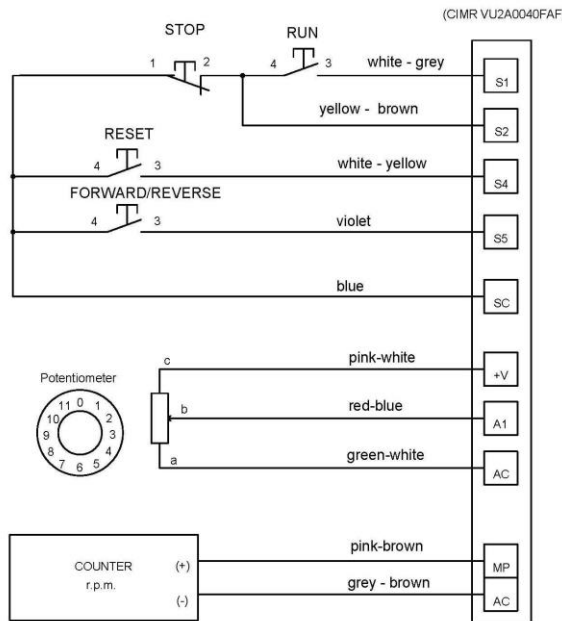
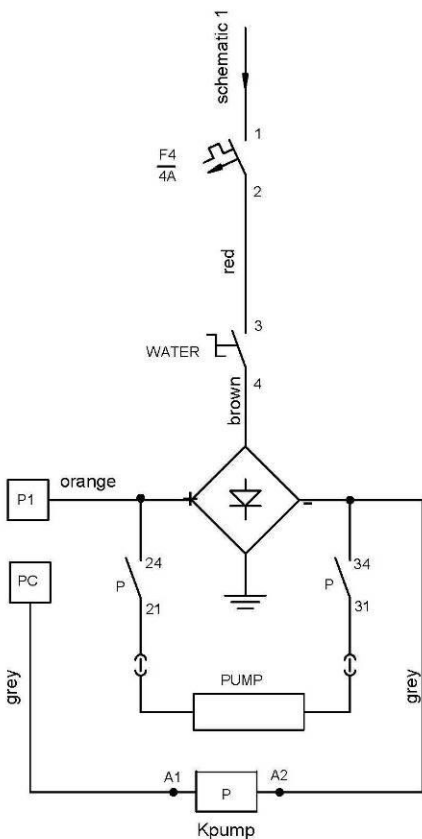
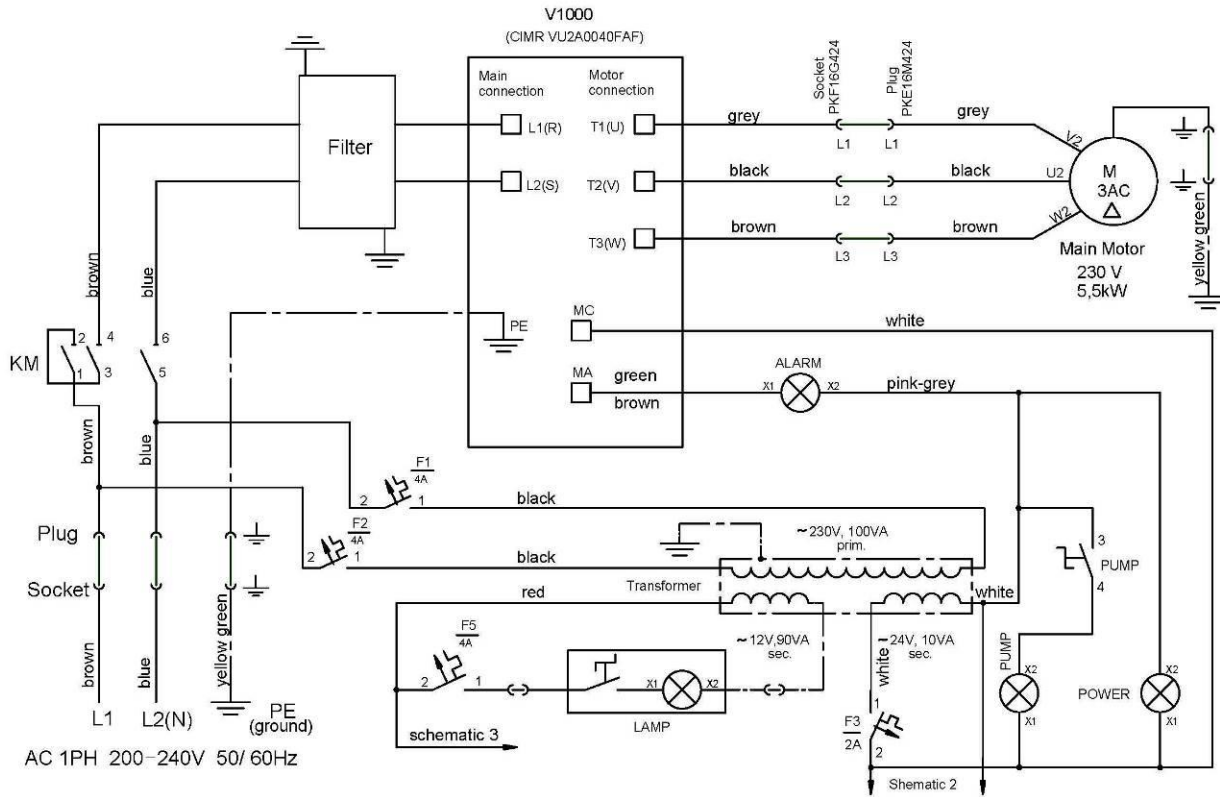

The motor is connected in "Delta" (triangle) 230 Volt, reminder for the wire connection of the motor.

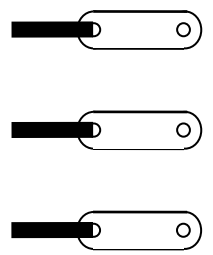

8.TROUBLESHOOTING

INDEX OF PROBLEMS AND SOLUTIONS

8.1 REPLACING POWER CORD AND PLUGS

When replacing the power cord or plugs, always use cords and plugs with specifications as the original ones.

Never use lower quality or different type cord and plugs.

In addition, take into consideration the distance of the appliance from the electrical source. The greater the distance, the greater the resistance and the less current that will be available at the other end; there will be a voltage drop and the inverter will sign alarm mode. This can also happen if several machines are working on the same line or when the generator is underrated. In general our standard power cable can be doubled in length; if longer lengths are needed you have to replace all the cables with bigger gage rated cables for the length and amperage.

8.2 DISMOUNTING TOOL HOLDER TO CHANGING V-RINGS AND FELT-RINGS



Figure 8.2.1

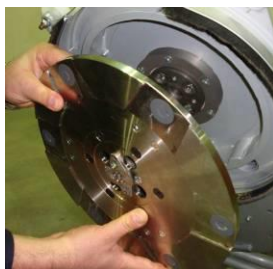

Figure 8.2.2



Figure 8.2.3



Figure 8.2.4



Figure 8.2.5

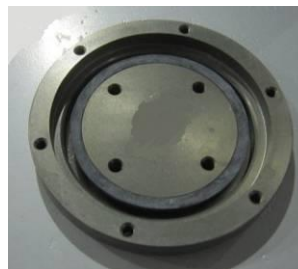

Figure 8.2.6

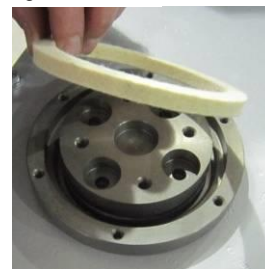

Figure 8.2.7



Figure 8.2.8

To check or replace the buffers and the elastic elements, the tool holders have to be dismantled.

You will need a 13mm deep metric socket with an outside diameter of no more than 3/4in to unscrew the four bolts (Fig.8.2.1) and remove the holder (Fig.8.2.2) When the tool holder is dismantled, you can change the sealers (V-Ring and Felt-Ring).

By loosening four Hex cap flange bolts (Fig.8.2.3) the adaptor comes loose. Unscrew the six screws of the cap (Fig.8.2.4) holding the felt-ring. Take out the Felt-Ring, adaptor and V-Ring.

Mount the V-Ring with the smallest lip of the V to the inside (Fig.8.2.5) - simply push the V-Ring so the top is on the same level as the pulley top (Fig.8.2.6). Then take the adaptor and push the V-Ring down with the adaptor (Fig.8.2.7). The lowest lip of the V-Ring should only barely touch its gliding surface. Mount the adaptor and the Felt-Ring on top (Fig.8.2.7). Close the sealers with the cap (Fig.8.2.8) and screw the bolts. Always use the original bolts. Do not push the V-ring down with fingers.

8.3 DISASSEMBLING AND MOUNTING TOOL HOLDER TO CHANGE BUFFERS AND ELASTIC ELEMENT

When the TOOL HOLDER is disassembled you can change defective parts – elastic element, buffers, etc.

Lift the locking pin (Fig.8.3.1) to dismount the retaining washer (Fig.8.3.2). Take out the screws on the buffers and the nuts of the elastic element (Fig.8.3.3;Fig.8.3.4). Remove the elastic element from the QC plate (Fig.8.3.5). While the holder is dismantled (Fig.8.3.6;Fig.8.3.7) clean the parts and replace the defective with new ones. Assemble the holder with new buffers with new screws and new elastic element. Put the retaining washer (Fig.8.3.8) and push the locking pin (Fig.8.3.9). This will prevent the fall of the washer when mounting the holder on the machine.



Figure 8.3.1



Figure 8.3.2

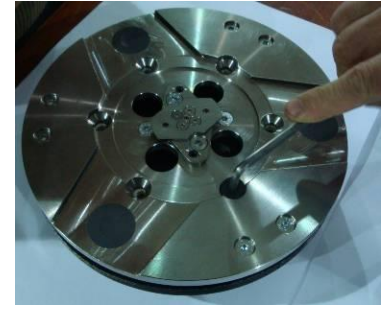

Figure 8.3.3

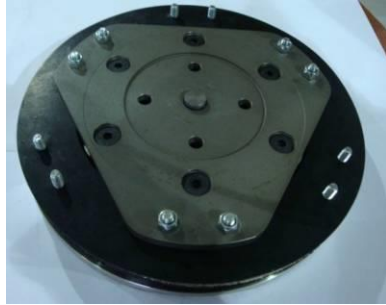

Figure 8.3.4



Figure 8.3.5



Figure 8.3.6



Figure 8.3.7



Figure 8.3.8

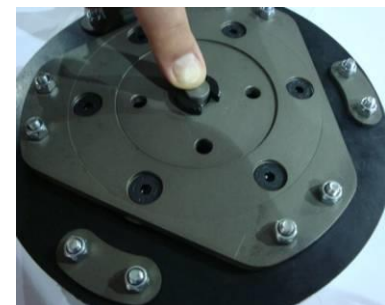

Figure 8.3.9

Make sure the four bolts holding the adaptor (Fig.8.3.12) are reliably tightened. Mount the holder on the machine using the same socket as in 8.2 (Fig.8.3.10;Fig.8.3.11). The retaining washer fits into the central hole C of adaptor and the four bolts into the thread holes T (Fig.8.3.12). The holder is centered on the outside diameter of the adaptor. Ensure the holder is properly connected to the plate of the adaptor and then tight evenly the four bolts. Tightening force on the bolts has to be 22...25N.m(16...18 lbf.ft). Mounting the holder without the retaining washer (Fig.8.3.2) is **INADMISSIBLE** because the security system preventing the separation of part of the holder in case of broken buffers and elastic element will not function! You can change the butterfly of the holder without dismounting the holder from the machine.



Figure 8.3.10

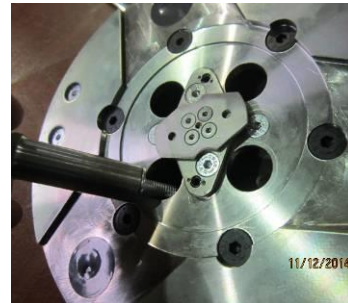

Figure 8.3.11

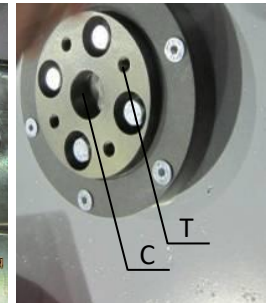

Figure 8.3.12

Fig.8.3.13 is 3-D section view of the holder, showing its parts. The numbering is the same as in Spare parts.

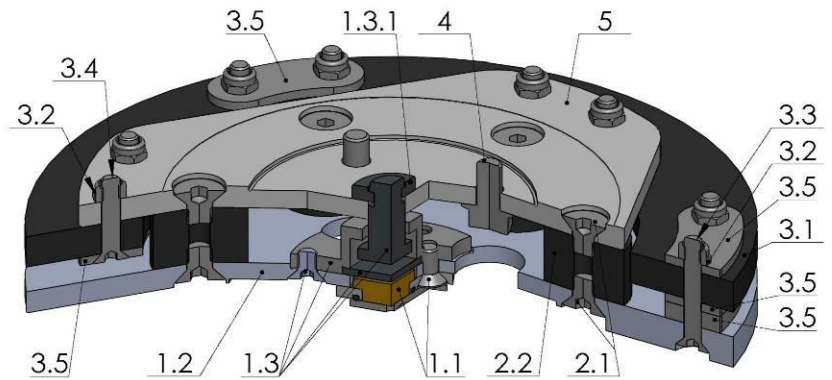

Figure 8.3.13



Figure 8.4.1

Figure 8.4.2

Figure 8.4.3

Figure 8.4.4

Figure 8.4.5

If the planetary belt slips or breaks, separate the carriage from main head, and disconnect the motor plug (Fig. 8.4.1), water-(Fig. 8.4.2) (Fig. 8.4.3) and vacuum tubes. Take off handles, forks and weight mounts to dismount the top cover (Fig. 8.4.4) (Fig. 8.4.5)

8.5 MOUNTING AND TENSIONING A NEW PLANETARY BELT

Make 2 signs on the dismounted belt exactly 10 cm apart (on belt not under tension) (Fig. 9.5.2). When under tension, the marks should be 10.2 cm apart, with a 2% tolerance.



Figure 8.5.1



Figure 8.5.2



Figure 8.5.3



Figure 8.5.4



Figure 8.5.5



Figure 8.5.6

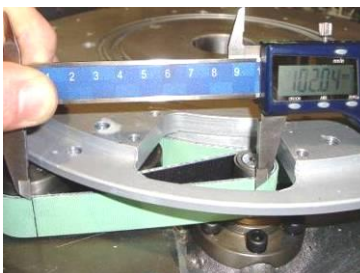

Figure 8.5.7



Figure 8.5.8



Figure 8.5.9

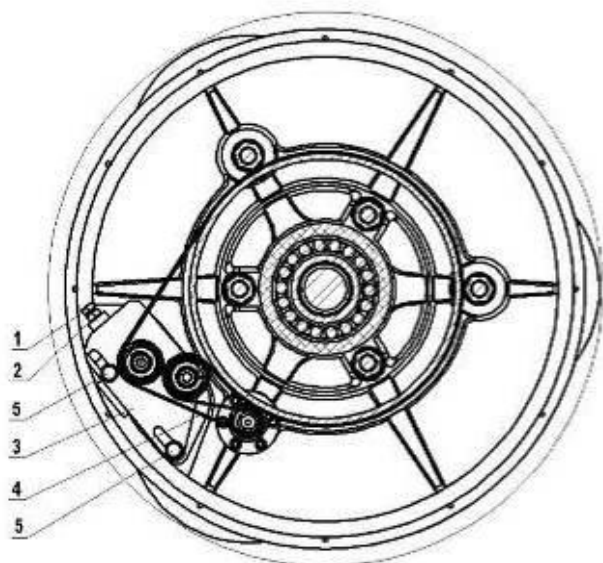

Figure 8.5.10

ATTENTION: NEVER “OVER” TENSION THE BELT, THE BELT WILL BE DAMAGED AND IT WILL NOT RECOVER ITS ORIGINAL TENSION

Reinstall the belt around the planetary pulley; ensuring the belt goes around the driving pulley (Fig. 8.5.3). Put the belt around the left roller of the tensioner (Fig. 8.5.4). Put the tensioner back in place and pull the belt from the roller on the right side (Fig. 8.5.5). Put the belt around the driving pulley (Fig. 8.5.6). Begin to tension until the 10 cm between the marks stretches to 10.2 cm(Fig. 8.5.7) (Fig. 8.5.8). **Rotate the head while tensioning to allow regular tension distribution along the belt.** Tighten the tensioner by turning the bolt. Move the planetary head so the belt has freedom to move. (Fig.8.5.8). Do not forget to retighten the screws on the tensioner (Fig.8.5.9).

8.6 TENSIONING USED PLANETARY BELT

If there is a loss of speed in the planetary motion, it is possible to re-tension a used planetary belt by following the instructions in 8.5 - Mounting and tensioning a new planetary belt.

8.7 REPLACING PULLEY UNITS



Figure 8.7.1



Figure 8.7.2



Figure 8.7.3

See previous chapters to remove the tool holders and top cover. Unscrew the screws lining the edge of the bottom cover (Fig. 8.7.1). Set the bottom cover assembly aside (Fig.8.7.2). Remove the O-rings to avoid losing them (Fig.8.7.3).



Figure 8.7.4



Figure 8.7.5



Figure 8.7.6

Only the two idle (non-driving) pulleys can be removed without removing the motor and base disc. Loosen the nut on top of the pulley (Fig.8.7.4). Carefully eject the unit with crowbars, but do not use excessive force (Fig.8.7.5) (Fig.8.7.6).

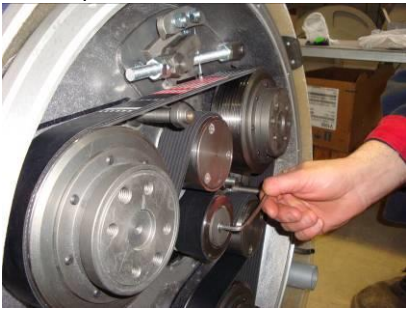

Figure 8.7.7

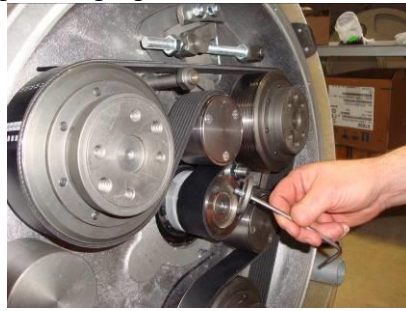

Figure 8.7.8



Figure 8.7.9

If all pulleys have to be replaced, dismantle motor base disc and motor. Before removing the belt, unscrew the central pulley (so it does not turn while dismantling) (Fig.8.7.7) (Fig.8.7.8). Pull off the central pulley (Fig.8.7.9).



Figure 8.7.10



Figure 8.7.11



Figure 8.7.12



Figure 8.7.13



Figure 8.7.14



Figure 8.7.15



Figure 8.7.16



Figure 8.7.17



Figure 8.7.18



Figure 8.7.19



Figure 8.7.20



Figure 8.7.21



Figure 8.7.22



Figure 8.7.23



Figure 8.7.24

Unscrew the bolts around the motor (Fig.8.7.10) and take the motor off (Fig.8.7.11). Detach the retaining shaft/bearing (Fig.8.7.12). Remove the filling ring (Fig.8.7.13). Now the motor base disc is free to be removed; however, the only way to displace it is to press it out on a bearing press (Fig.8.7.14) (Fig.8.7.15).

Dismounting the driving pulley: take the top screw out to release the bushing (Fig.8.7.16), push up the bushing and washer together (Fig.8.7.17), push the washer down to separate them, and then remove the bushing (Fig.8.7.18). Pull out the key (Fig.8.7.19). This will release the washer. Remove it (Fig.8.7.20), dismount sealer cap (Fig.8.7.21). Now, dismount the pulley using two crowbars; do not use excessive force (Fig.8.7.22) (Fig.8.7.23). Push the sealer cap to dismount (Fig.8.7.24). When replacing the sealer cap, be sure to secure with sealant and center the holes to mount the pulley.



Figure 8.7.25



Figure 8.7.26



Figure 8.7.27

Change the two other pulleys as earlier described. While the motor base is dismounted, roller units can also be changed easily. Unscrew the nut on top (Fig.8.7.25). The pulleys can be released with two crowbars; do not use excessive force (Fig.8.7.26) (Fig.8.7.27).

8.8 MOUNTING THE BELT



Figure 8.8.1



Figure 8.8.2



Figure 8.8.3



Figure 8.8.4



Figure 8.8.5



Figure 8.8.6



Figure 8.8.7



Figure 8.8.8



Figure 8.8.9

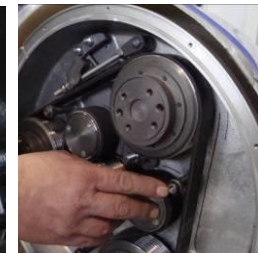

Figure 8.8.10

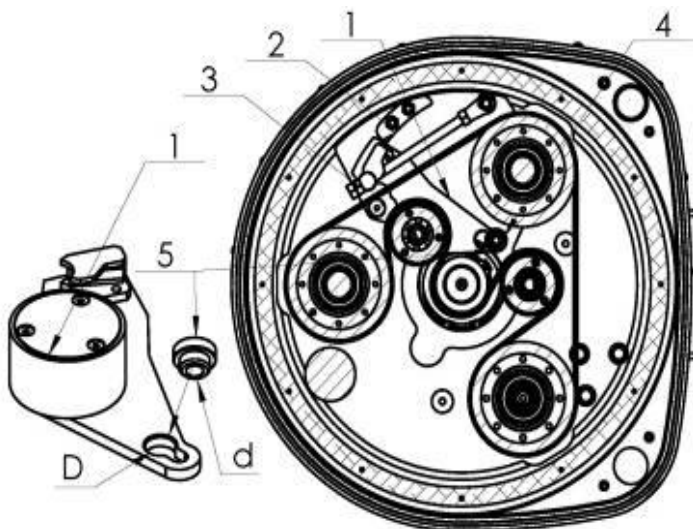

Figure 8.8.11

The proper orientation of the belt is shown in Fig.8.8.11. The belt can be installed when the tensioner is fully loosened. This can be done by loosening nuts (2) and (3). Unscrew the nut (4) and removing bushing (5) from hole D in the tensioner (1). This will allow the tensioner to move freely.

The belt should be installed as shown in Figs.8.8.1-4, starting around the central pulley and weaving outward until all units are connected. Ensure that the belt is in the correct orientation, and that the grooves of the belts/pulleys line up at each location.

Position the tensioner such that the bushing (5) can be reinserted into the hole D. (The bushing can be pressed by screwing screw (4)) (Fig.8.8.4)

Tighten the nuts (2) (Fig. 8.8.5) on the sectors and then loosen by a half revolution. This will allow the tensioner turn with minimal force. Fasten the bolt (Fig. 8.8.7) in order to achieve the right Tension and then tighten the center nut of the tensioner (Fig. 8.8.6).

It is recommended that the tensioning of the belt be measured with Optikrik II Device (Measuring range: 500-1400 N) (Fig. 8.8.8). The tension of the existing belt must be 520 N. The tension of the new belt must be 650N

ATTENTION: NEVER “OVER” TENSION THE BELT, THE BELT WILL BE DAMAGED AND IT WILL NEVER RECOVER ITS ORIGINAL TENSION

Tighten the two nuts on the sectors and counter nut on the tensioner (Fig. 8.8.10). Put the seal ring on the bottom cover and close the machine (Fig. 8.8.11).

Reassemble in the same manner.

Your LAVINA® X-E machine is now ready for use!

8.9 CHECKING THE TENSION OF THE BELT



Figure 8.9.1



Figure 8.9.2



Figure 8.9.3



Figure 8.9.4

Open the checking cover to reach the belt and tensioner (Fig.8.9.1). While tensioning, regularly check the tension to ensure that you never tighten it too much. It is recommended that the tensioning of the belt be measured with an Optikrik II Device (Measuring range: 500 -1400 N) (Fig.8.9.2). Fastening force should be 520 N.

ATTENTION:

NEVER “OVER” TENSION THE BELT, THE BELT WILL BE DESTROYED AND IT WILL NEVER RECOVER ITS ORIGINAL TENSION

Loosen the counter nuts (Fig.8.9.3), loose light the two nuts of the tension device (Fig.8.9.4), and adjust the tension with the nut seen in Fig.8.9.3. When the right tension is reached: close the counter nuts and the two nuts of the support. Reassemble in the same manner.

PLEASE MAKE SURE YOU CHECK THE TENSION OF THE BELT AFTER THE FIRST 15 HOURS OF OPERATION

8.10 MOTOR CONNECTION

When changing the motor, please check the cable connection to your motor.

Lavina®20N X-E

The motor is connected in “Star” 380 Volt, reminder for the wire connection of the motor.

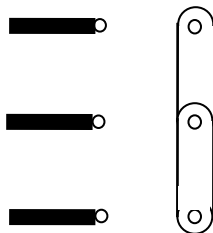

Figure 8.10.1

Lavina®20NX-OE

The motor is connected in “Delta” (Triangle) 230 Volt, reminder for the wire connection of the motor.

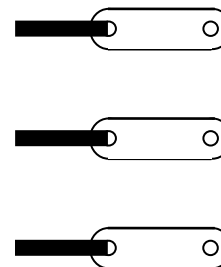

Figure 8.10.2

8.11 Fault diagnosis Inverter YASKAWA V1000

Pages are referring to

Yaskawa Electric SIEP C710606 18A YASKAWA AC Drive – V1000 Technical Manual

◆ Types of Alarms, Faults, and Errors

Check the LED operator for information about possible faults if the drive or motor fails to operate. [Refer to Using the Digital LED Operator on page 70.](#)

If problems occur that are not covered in this manual, contact the nearest Yaskawa representative with the following information:

- Drive model
- Software version
- Date of purchase
- Description of the problem

[Table 6.4](#) contains descriptions of the various types of alarms, faults, and errors that may occur while operating the drive. Contact Yaskawa in the event of drive failure.

Table 6.4 Types of Alarms, Faults, and Errors

Type	Drive Responses to Alarms, Faults, and Errors
Faults	When the drive detects a fault: <ul style="list-style-type: none"> • The digital operator displays text that indicates the specific fault and the ALM indicator LED remains lit until the fault is reset. • The fault interrupts drive output and the motor coasts to a stop. • Depending on the setting, the drive and motor may stop via different methods than listed. • If a digital output is programmed for fault output (H2-□□ = E), it will close if a fault occurs. • When the drive detects a fault, it will remain inoperable until that fault has been reset. Refer to Fault Reset Methods on page 264.
Minor Faults and Alarms	When the drive detects an alarm or a minor fault: <ul style="list-style-type: none"> • The digital operator displays text that indicates the specific alarm or minor fault and the ALM indicator LED flashes. • The motor does not stop. • One of the multi-function contact outputs closes if set to be tripped by a minor fault (H2-□□ = 10), but not by an alarm. • The digital operator displays text indicating a specific alarm and ALM indicator LED flashes. • Remove the cause of an alarm or minor fault to automatically reset.
Operation Errors	When parameter settings conflict with one another or do not match hardware settings (such as with an option card), it results in an operation error. When the drive detects an operation error: <ul style="list-style-type: none"> • The digital operator displays text that indicates the specific error. • Multi-function contact outputs do not operate. • When the drive detects an operation error, it will not operate the motor until the error has been reset. Correct the settings that caused the operation error to reset.
Tuning Errors	Tuning errors occur while performing Auto-Tuning. When the drive detects a tuning error: <ul style="list-style-type: none"> • The digital operator displays text indicating the specific error. • Multi-function contact outputs do not operate. • Motor coasts to stop. • Remove the cause of the error and repeat the Auto-Tuning process.

◆ Alarm and Error Displays

■ Faults

When the drive detects a fault, the ALM indicator LEDs remain lit without flashing. If the LEDs flash, the drive has detected a minor fault or alarm. [Refer to Minor Faults and Alarms on page 240](#) for more information. An overvoltage situation trips both faults and minor faults, therefore it is important to note whether the LEDs remain lit or if the LEDs flash.

LED Operator Display	Name	Page	LED Operator Display	Name	Page
bUS	bUS Option Communication Error	242	CPF08	EEPROM Serial Communications Fault	243
CE	MEMOBUS/Modbus Communication Error	242	CPF11	RAM Fault	243
CF	Control Fault	242	CPF12	FLASH Memory Fault	243
CoF	Current Offset Fault	242	CPF13	Watchdog Circuit Exception	243
CPF02	A/D Conversion Error	242	CPF14	Control Circuit Fault	243
CPF03	PWM Data Fault	243	CPF16	Clock Fault	243
CPF06	Drive specification mismatch during Terminal Board or Control Board replacement	243	CPF17	Timing Fault	243
CPF07	Terminal Board Communication Fault	243	CPF18	Control Circuit Fault	243
			CPF19	Control Circuit Fault	244

LED Operator Display	Name	Page
CPF20 or CPF21	RAM Fault	244
	FLASH Memory Fault	244
	Watchdog Circuit Exception	244
	Clock Fault	244
oH3	oH3 Motor Overheat 1 (PTC input)	247
oH4	oH4 Motor Overheat 2 (PTC input)	248
oL1	oL1 Motor Overload	248
oL2	oL2 Drive Overload	248
oL3	oL3 Overtorque Detection 1	249
oL4	oL4 Overtorque Detection 2	249
oL5	oL5 Mechanical Weakening Detection 1	249
oL7	oL7 High Slip Braking oL	249
oPr	oPr Operator Connection Fault	249
CPF22	CPF22 A/D Conversion Error	244
CPF23	CPF23 PWM Feedback Data Fault	244
CPF24	CPF24 Drive Capacity Signal Fault	244
dEv	dEv Excessive Speed Deviation (for Simple V/f with PG)	244
EF0	EF0 Option Card External Fault	244
EF1 to EF7	EF1 to EF7 External Fault (input terminal S1 to S7)	244
FbH	FbH Excessive PID Feedback	245
FbL	FbL PID Feedback Loss	245

LED Operator Display	Name	Page
GF	GF Ground Fault	245
LF	LF Output Phase Loss	245
LF2	LF2 Output Open Phase	246
oC	oC Overcurrent	246
oFA00	oFA00 Option Card Fault (port A)	246
oH	oH Heatsink Overheat	247
oH1	oH1 Heatsink Overheat	247
PGo	PGo PG Disconnect (for Simple V/f with PG)	250
rH	rH Dynamic Braking Resistor	251
rr	rr Dynamic Braking Transistor	251
SEr	SEr Too Many Speed Search Restarts	251
STO	STO Pull-Out Detection	251
UL3	UL3 Undertorque Detection 1	251
UL4	UL4 Undertorque Detection 2	251
UL5	UL5 Mechanical Weakening Detection 2	251
Uv1	Uv1 Undervoltage	252
Uv2	Uv2 Control Power Supply Undervoltage	252
Uv3	Uv3 Soft Charge Circuit Fault	252
oS	oS Overspeed (for Simple V/f with PG)	249
ov	ov Overvoltage	249
PF	PF Input Phase Loss	250

Note: If faults CPF11 through CPF19 occur, the LED operator will display CPF00 or CPF11.

■ Minor Faults and Alarms

When a minor fault or alarm occurs, the ALM LED flashes and the text display shows an alarm code. A fault has occurred if the text remains lit and does not flash. Refer to Alarm Detection on page 253. An overvoltage situation, for example, can trigger both faults and minor faults. It is therefore important to note whether the LEDs remain lit or if the LEDs flash.

Table 6.5 Minor Fault and Alarm Displays

LED Operator Display	Name	Minor Fault Output (H2-□□ = 10)	Page
bb	bb Drive Baseblock	No output	253
bUS	bUS Option Card Communications Error	YES	253
CALL	CALL Serial Communication Transmission Error	YES	253
CE	CE MEMOBUS/Modbus Communication Error	YES	253
CrSt	CrSt Can Not Reset	YES	253
dEv	dEv Excessive Speed Deviation (for Simple V/f with PG)	YES	254
dnE	dnE Drive Disabled	YES	254
EF	EF Run Command Input Error	YES	254
EF0	EF0 Option Card External Fault	YES	254
EF1 to EF7	EF1 to EF7 External Fault (input terminal S1 to S7)	YES	255
FbH	FbH Excessive PID Feedback	YES	255
FbL	FbL PID Feedback Loss	YES	255
Hbb	Hbb Safe Disable Signal Input	YES	255
HbbF	HbbF Safe Disable Signal Input	YES	255
SE	SE MEMOBUS/Modbus Test Mode Fault	YES	—
oL5	oL5 Mechanical Weakening Detection 1	YES	249
UL5	UL5 Mechanical Weakening Detection 2	YES	251
dWAL	dWAL DriveWorksEZ Alarm	YES	244
HCA	HCA Current Alarm	YES	256
oH	oH Heatsink Overheat	YES	256
oH2	oH2 Drive Overheat	YES	256
oH3	oH3 Motor Overheat	YES	256
oL3	oL3 Overtorque 1	YES	256
oL4	oL4 Overtorque 2	YES	257
oS	oS Overspeed (for Simple V/f with PG)	YES	257

LED Operator Display		Name	Minor Fault Output (H2-□□ = 10)	Page
ou	ov	Overvoltage	YES	257
PASS	PASS	MEMOBUS/Modbus Test Mode Complete	No output	257
PGo	PGo	PG Disconnect (for Simple V/f with PG)	YES	257
rUn	rUn	During Run 2, Motor Switch Command Input	YES	258
rUnC	rUnC	Run Command Reset	YES	258
UL3	UL3	Undertorque 1	YES	258
UL4	UL4	Undertorque 2	YES	258
Uv	Uv	Undervoltage	YES	258

■ Operation Errors

Table 6.6 Operation Error Displays

LED Operator Display		Name	Page	LED Operator Display		Name	Page
oPE01	oPE01	Drive Unit Setting Error	259	oPE08	oPE08	Parameter Selection Error	260
oPE02	oPE02	Parameter Setting Range Error	259	oPE09	oPE09	PID Control Selection Error	260
oPE03	oPE03	Multi-Function Input Setting Error	259	oPE10	oPE10	V/f Data Setting Error	261
oPE04	oPE04	Terminal Board Mismatch Error	260	oPE11	oPE11	Carrier Frequency Setting Error	261
oPE05	oPE05	Run Command Selection Error	260	oPE13	oPE13	Pulse Train Monitor Selection Error	261
oPE07	oPE07	Multi-Function Analog Input Selection Error	260				

9. WARRANTY AND RETURNS

WARRANTY POLICY FOR THE LAVINA® X-E MACHINE

Superabrasive Ltd. guarantees that the original purchaser of the Lavina® X-E machine will be covered against defects in material and workmanship for a period of 2 years from the date of delivery or 600 hours of use whichever comes first.

The following conditions pertain to this warranty:

- Applies only to the original owner and it is not transferable.
- Machine must not be dismantled and tampered with in any way.
- Covered components proven defective will be repaired or replaced at no charge. Covered components include motors, bearings and switches.
- This warranty does not apply to any repair arising from misuse, neglect or abuse, or to repair of proprietary parts.
- This warranty does not apply to products with aftermarket alterations, changes, or modifications.
- This warranty is in lieu of and excludes every condition of warranty not herein expressly set out and all liability for any form of consequential loss or damage is hereby expressly excluded.
- This warranty is limited to repair or replacement of covered components and reasonable labor expenses.
- All warranty returns must be shipped freight prepaid.

The above warranty conditions may be changed only by Superabrasive. Superabrasive reserves the right to inspect and make a final decision on any machine returned under this warranty. This warranty applies to new, used and demo machines.

Superabrasive does not authorize any person or representative to make any other warranty or to assume for us any liability in connection with the sale and operation of our products

RETURN POLICY FOR LAVINA® X-E MACHINES

The Lavina® X-E machines may be returned, subject to the following terms:

In no case, a machine is to be returned to Superabrasive Ltd. for credit or repair without prior authorization. Please contact Superabrasive Ltd. or your local distributor for an authorization and issuance of a return authorization number. This number along with the serial number of the machine must be included on all packages and correspondence. Machines returned without prior authorization will remain property of the sender and Superabrasive Ltd. will not be responsible for these.

10. DISPOSAL

If your machine after time is not usable or needs to be replaced, send the machine back to Superabrasive or a local distributor, where a professional disposal complying with the environment laws and directives is guaranteed.

11. MANUFACTURER'S CONTACTS

If you need to contact Superabrasive Ltd. with technical support questions, below is the contact information.

Address:	Superabrasive Ltd. Rabotnicheska 2A BG-6140 Krun Bulgaria	Email:	factory@superabrasive.com
		Tel.:	+359 431 6 44 77
		Fax:	+359 431 6 44 66
		Website:	www.superabrasive.com

12. SPARE PARTS

ASSEMBLY AND PARTS SPECIFICATIONS

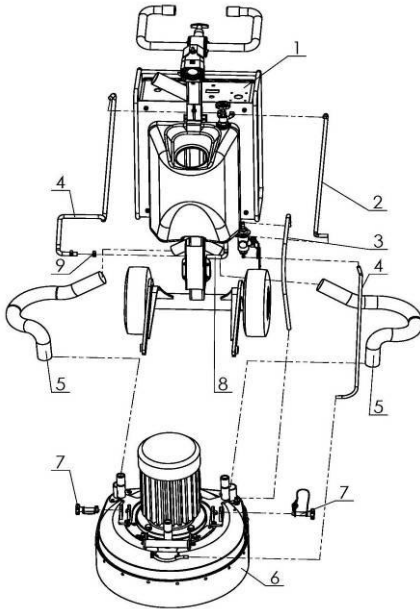

1. LAVINA®20N-X-E GENERAL PARTS			
No.	Item No.	Description	Pcs.
1	L20NXE-20.00.00	Carriage for Lavina20NXE	1
1	L20NXOE-20.00.00	Carriage for Lavina20NXOE	1
2	MAR8.71	Tube	1
3	MAR8.78	Tube	1
4	MAR8.86	Tube	2
5	D40L820	Vacuum Hose	2
6	L20NXS-10.00.00	Main Head	1
7	L25SPS-07.03.00.00	Pin Assembly	2
8	MAR8.25	Tube	1
9	10-16DIN3017	Clamp	5

2. LAVINA®20N-X-E TOP COVER PARTS 1			
No.	Item No.	Description	Pcs.
1	L20X-19.00.00	Top Cover Assembly	1
2	L20SPS-05.00.00.00	Guard Assembly	1
2**	L20X-05.00.00	Guard Assembly	1
3	L20X-18.00.00	Machine Support	1
4	L25SPS-07.00.00.05	Weight Holder	3
5	L25SPS-07.00.00.29	Rubber Buffer	3
6	M8X16DIN6921	Bolt	6
7	M8X16DIN7991	Screw	2
8	M5X12DIN6921	Bolt	2
9	A29.10.00-01	Spray Unit	1
	9.1	H766-21 Knob Bolt	1
10	L20X-10.10.00	Handle	1
11	M6X10ISO7380F	Screw	8
12	L20S-15.00.20	Inspection Cover	1

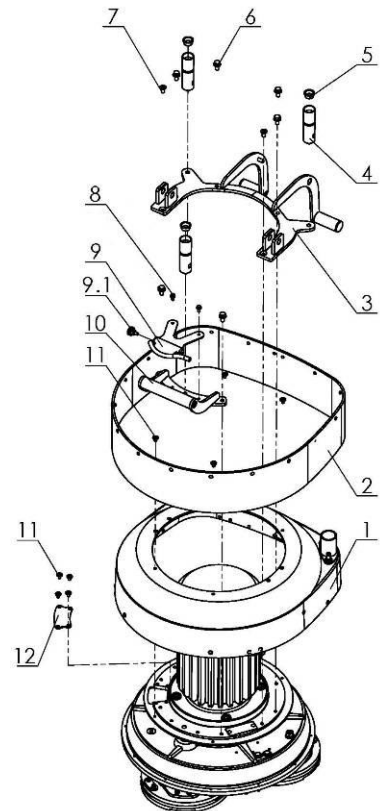

** for machines after Serial No 1710L20NXOE1605

** for machines after Serial No 1710L20NXE1805

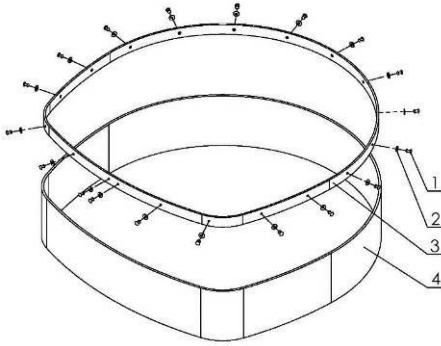

3. LAVINA®20N-X-E GUARD PARTS			
No.	Item No.	Description	Pcs.
1	D4X10DIN7337	Rivet	18
2	M4DIN9021A	Washer	18
3	L20SPS-05.00.00.01	Ring	1
4	L20SPS-05.00.00.02	Guard	1

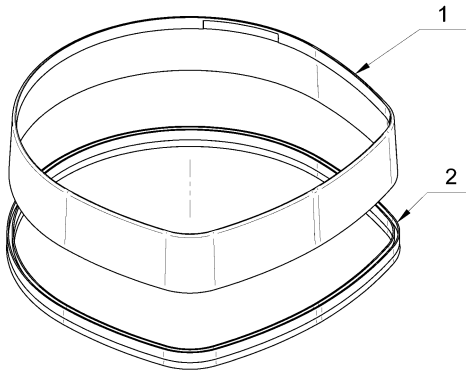

3.1 LAVINA®20N-X-E GUARD PARTS			
** for machines after Serial No 1710L20NXOE1605			
** for machines after Serial No 1710L20NXE1805			
No.	Item No.	Description	Pcs.
1	L20X-05.00.00.01	Guard	1
2	FBL1350-1838	Brush	1

4. LAVINA®20N-X-E TOP COVER PARTS 3			
No.	Item No.	Description	Pcs.
1	M5X16DIN84A	Screw	3
2	L25SPS-04.01.00.00	Vacuum Port	1
4	M5DIN127B	Spring Washer	3
3	M5DIN125A	Washer	3
5	M5DIN934	Nut	3
6	M12DIN985	Nut	1
7	L20X-19.00.01	Top Cover	1
8	L25GS-19.10.00	Vacuum Port	1
9	L21X-15.01.00	Water Fitting	1

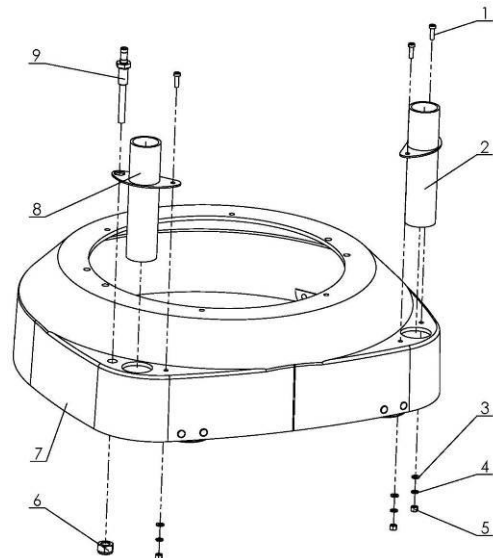

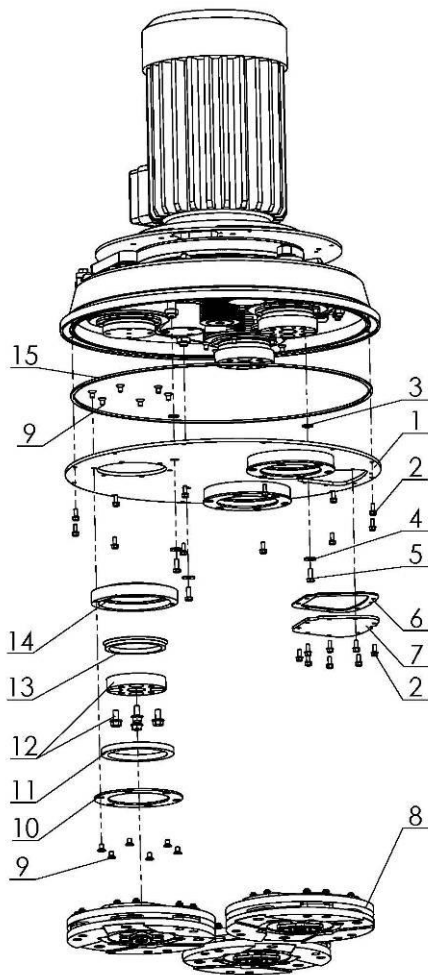

5. LAVINA®20N-X-E BOTTOM COVER PARTS 1			
No.	Item No.	Description	Pcs.
1	L20NS-14.00.00	Bottom Cover Assembly	1
2	M5X12DIN6921	Bolt	20
3	D12X2	O-Ring	3
4	M6DIN9021A	Washer	3
5	M6X16DIN6921	Bolt	3
6	L20NS-14.00.05	Sealer Inspection Cover	1
7	L20NS-14.00.04	Inspection Cover	1
8	A41.00.00	Tool Holder A41	3
9	M6X10DIN7991	Screw	36
10	L25LS-14.00.03	Outer Cover	3
11	110X90X8.5	Felt Ring	3
12	A42.03.00	Adaptor	3
13	TWVA00800	V-Ring Type A	3
14	L25LS-14.00.02	Flange	3
15	D4X2X1450	Seal	1

* for machines to serial number No1606L20NXE2310

6*. LAVINA®20N-X-E Planetary drive Parts			
No.	Item No.	Description	Pcs.
1*	1125-AT5-16	Endless Transmission Belt	1
2*	L20X-17.00.00	Planetary Tensioning Unit	1
2.1*	L20X-17.11.00	Idler T	1
2.2*	L20X-17.13.00	Idler 20X	1

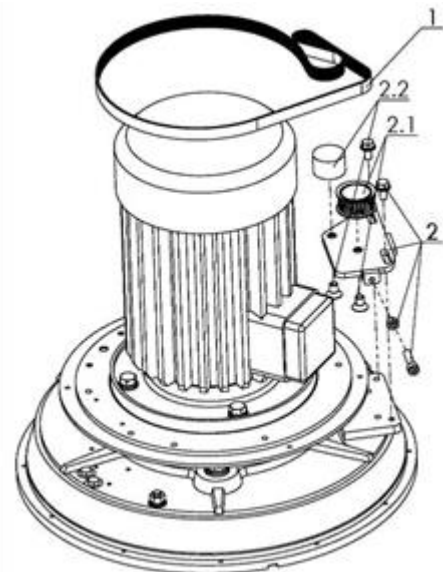

6. LAVINA® 20N-X-E PLANETARY DRIVE PARTS			
No.	Item No.	Description	Pcs.
1	TC-20EF1110X20X2	Endless Transmission Flat Belt	1
2	L20S-17.00.00	Planetary Tensioning Unit	1
2.1	L25S-17.11.00	Idler	2
	KP-L20X-L20S	KIT TO CHANGE L20X PLANETARY TO L20S	1

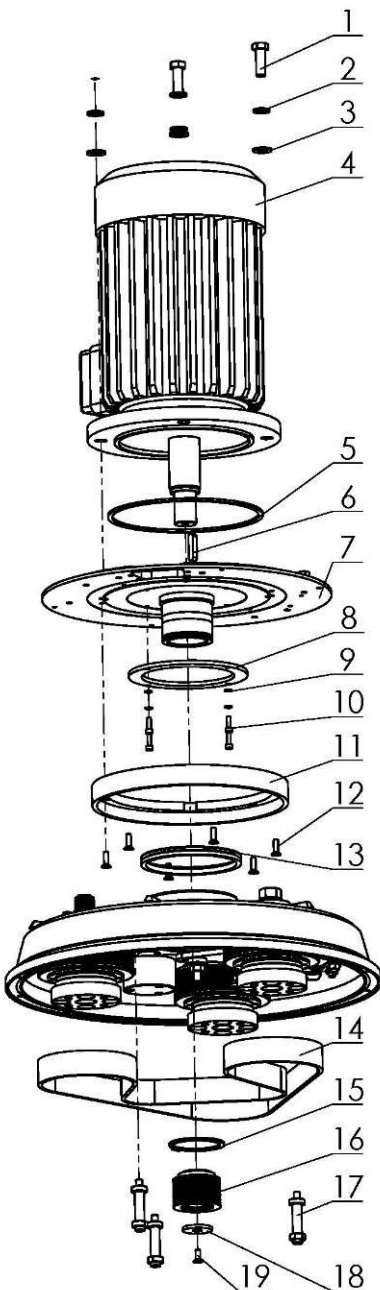
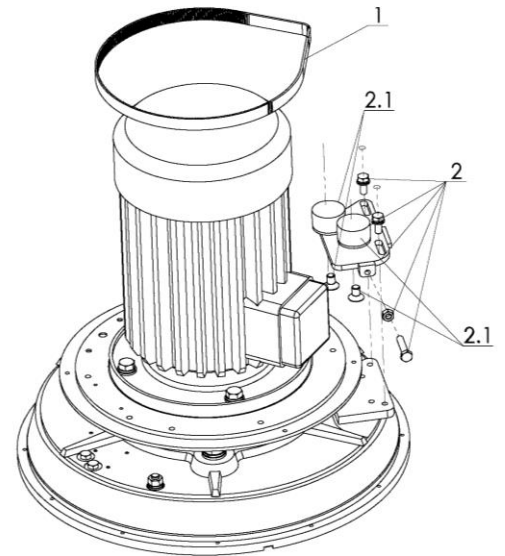

7. LAVINA® 20N-X-E BOTTOM COVER PARTS 2			
No.	Item No.	Description	Pcs.
1	M12X35DIN933	Bolt	4
2	M12DIN127B	Spring Washer	4
3	M12DIN125A	Washer	4
4	S203	Electro Motor	1
5	D4X2X650	Seal	1
6	DIN6885A8X7X36	Key	1
7	L20X-15.01.00	Base Plate	1
8	L25P-01.03.00.09	Flange	1
9	M5DIN7980	Spring Washer	4
10	M5X16DIN912	Screw	4
11	L20S-15.00.21	Planetary Pulley	1
12	M6X20DIN7991	Screw	1
13	TWVA01200	V-Ring Type A	1
14	1725PK9	Endless Transmission V Belt	1
15	B65DIN471	Retaining Ring	1
16	L20NS-00.00.08	Central Pulley	1
17	L20NS-10.00.20	Distance Screw	3
18	L25SPS-00.00.00.15	Front Washer	1
19	M6X16DIN7991	Screw	1

8. LAVINA®20N-X-E PULLEY UNIT PARTS 2

No.	Item No.	Description	Pcs.
1	L20XS-16.00.00	Driving Pulley Unit	1
1.1	M6X12DIN7991	Screw	1
1.2	L25S-16.00.16	Cap	1
1.3	L20S-16.00.15	Driving pulley	1
1.4	DIN6885A5x3x16	Key	1
2	L20NS-10.00.10	Disc	1
3	6013	Roller Assembly	2
4	L25SPS-00.00.00.34	Distance Ring	1
5	A10013943	Retaining Ring	2
6	L20P-01.05.00.00	Roller Unit Assembly	1
7	L20NS-10.00.14	Axle Bushing	1
8	M10DIN127B	Spring Washer	1
9	M10DIN934	Nut	1
10	L20X-11.00.00	Pulley Unit Assembly	2
11	B10DIN471	Retaining Ring	1
12	L32C.14.20.04	Nut	1
13	M10DIN934	Nut	2
14	M8DIN934	Nut	2
15	M8DIN127B	Spring Washer	2
16	L20NS-10.00.11	Sector	1
17	L20NS-12.00.00	Tensioning Support	1
18	L20NS-10.00.12	Sector	1

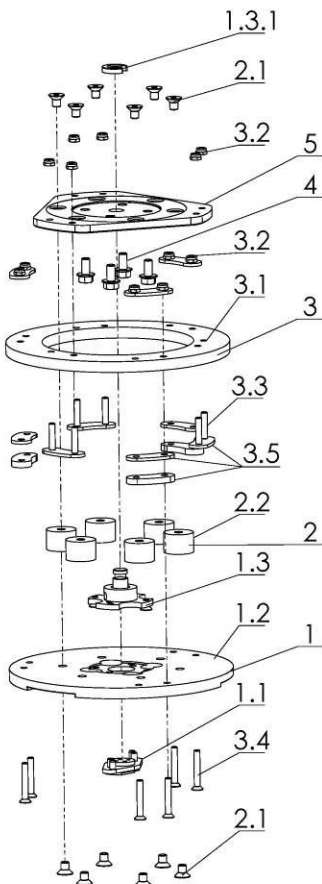
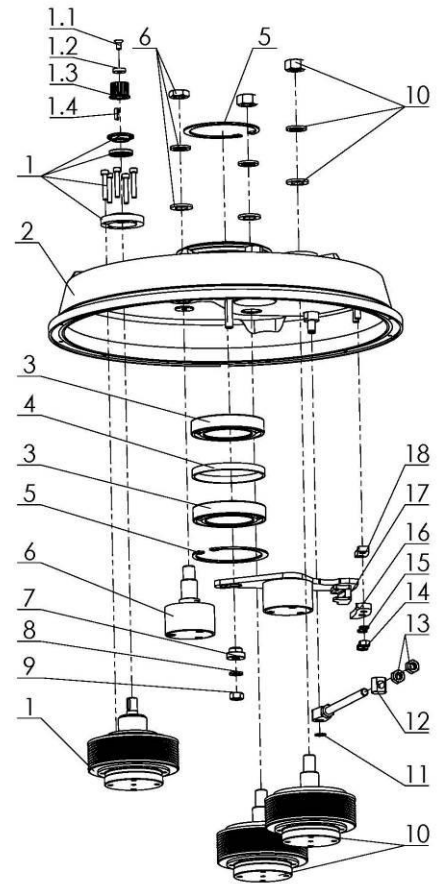

9. LAVINA®20N-X-E TOOL HOLDER PARTS /SEE ALSO FIG.8.3.13/ (POS.1 INCLUDE POS.1.1;1.2;1.3/POS.1.3 INCLUDE POS.1.3.1 and etc.)

No.	Item No.	Description	Pcs.	
1	A41.10.00	Quick Change Assembly	1	
	1.1	A31.12.00	Keylock Set	1
	1.2	A41.11.00	Quick Change plate	1
	1.3	A41.12.00	Security set	1
	1.3.1	A41.00.05	Washer A41	1
2	A25.00.10-K	Buffer with two screw	6	
	2.1	M8X12DIN7991	Screw	12
	2.2	A25.00.10	Buffer	6
3	A41.20.03-K	Driving Set A41	1	
	3.1	A41.20.03	Elastic Element	1
	3.2	M6DIN985	Self Locking Nut	12
	3.3	M6X40DIN7991	Screw	6
	3.4	M6X30DIN7991	Screw	6
	3.5	A41.21.00	Set of plates	1
4	3.1	M8x16DIN6921	Bolt	4
5		A41.20.01	Flange	1

10. LAVINA®20N-X-E WATER TANK PARTS

No.	Item No.	Description	Pcs.
1	A29.50.00	Regulator	1
2	1/2"	Filter	1

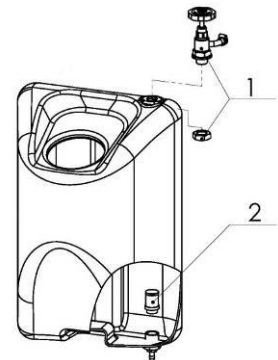

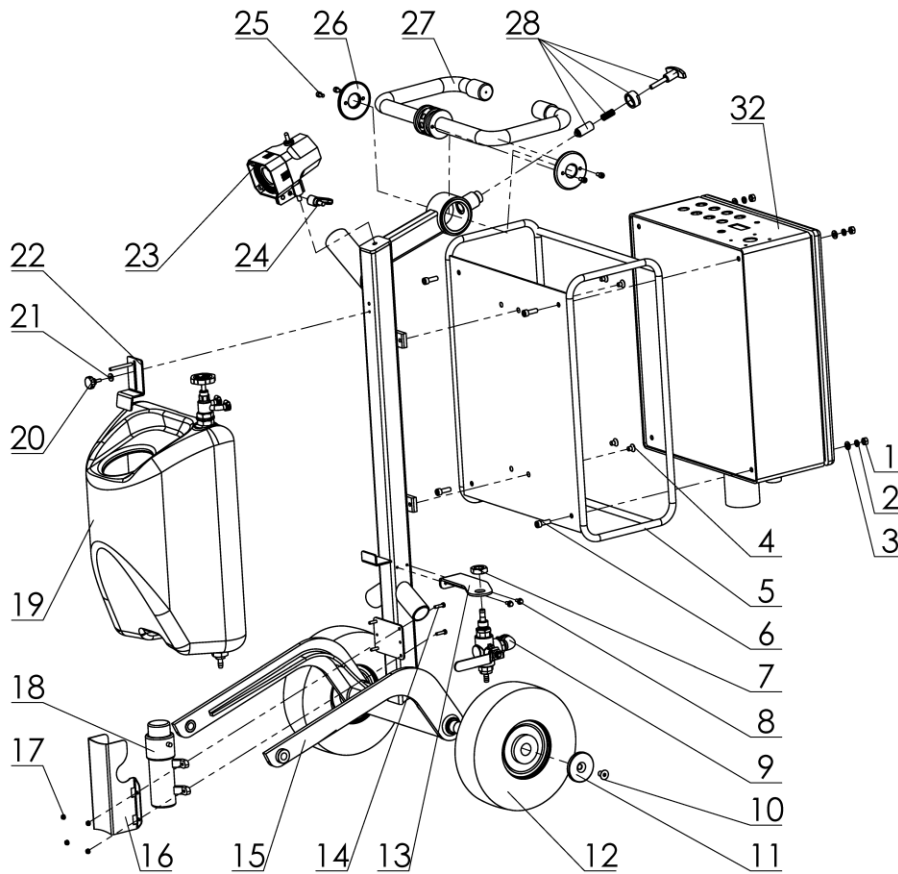

11. LAVINA®20N-X-E/ LAVINA®20N-X-OE CARRIAGE PARTS

No.	Item No.	Description	Pcs.	No.	Item No.	Description	Pcs.
1	M8DIN934	Nut	4	16	L25S-20.00.26	Guard	1
2	M8DIN127B	Spring Washer	4	17	M5DIN985	Nut	4
3	M8DIN125A	Washer	4	18	See table12 pos.14	Water Pump	1
4	M8X12DIN7991	Screw	4	19	A33.10.00	Tank	1
5	L25S-22.00.00	Guard	1	20	T34391	Knob Bolt	1
6	M8X25DIN912	Screw	4	21	M5UN732	Washer	1
7	M20X1.5DIN439B	Nut	1	22	L25P-02.00.00.01	Top Bracket	1
8	M5X12DIN6921	Bolt	2	23	L20NS-30.30.00	Lamp Unit Incl. Cable	1
9	A29.40.00	Water Flow Control Unit	1	24	A58165	Swivel Bolt	1
10	M10X16DIN7991	Screw	2	25	M6X12DIN912	Screw	4
11	L32D-20.00.03	Cap	2	26	L20X-20.00.02	End Cover	2
12	LRS2260K25PR4	Wheel	2	27	L20X-23.10.00	Handle Assembly	1
13	A29.20.01-01	Flow Unit Base	1	28	L20X-23.10.06-K	Locking bit	1
14	M5X20DIN933	Bolt	4	32	L20NXE-30.00.00	Control Box for Lavina20NXE	1
15	L20X-21.00.00	Carriage	1	32	L20NXOE-30.00.00	Control Box for Lavina20NXOE	1

12.LAVINA® 20N-X-E CONTROL BOX PARTS

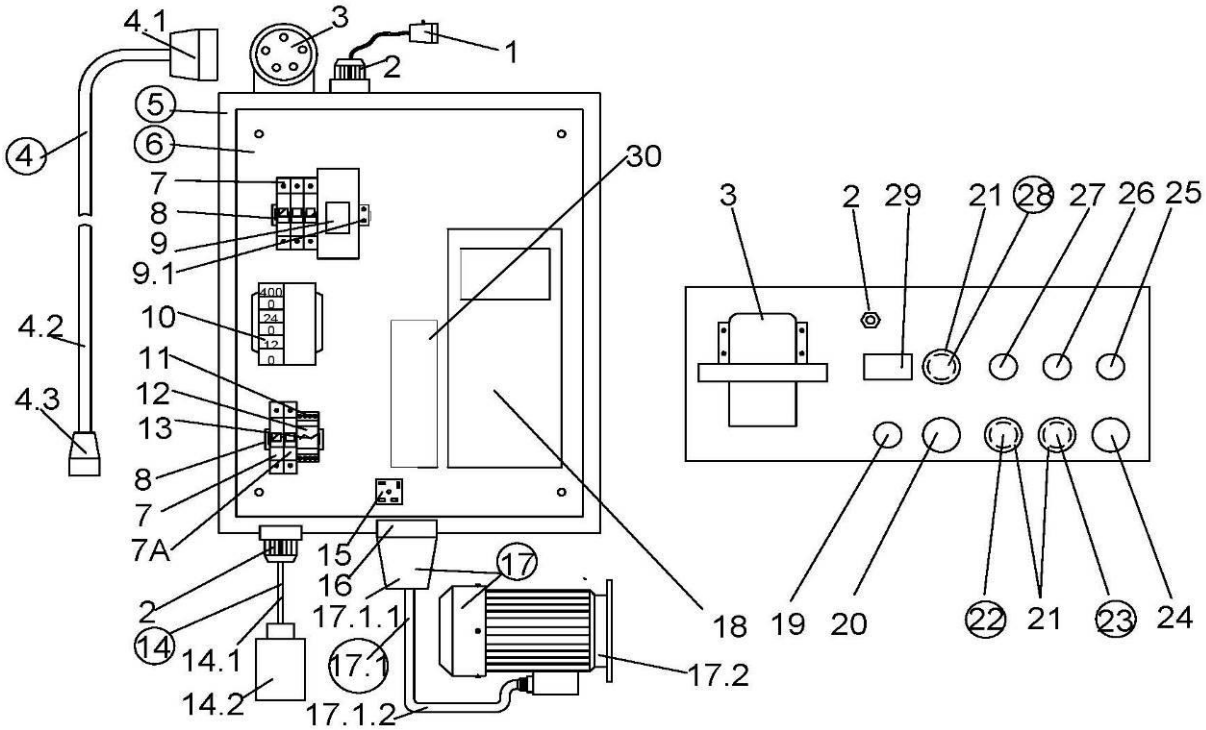

12. LAVINA® 20N-X-E CONTROL BOX PARTS 380-400 VOLT

No.	Item No.	Description	Pcs.	No.	Item No.	Description	Pcs.
1	L20NS-30.30.00	Lamp Unit Incl. Cable	1	16	L20NHVS-30.10.03	Socket	1
2	L20NS-30.10.01	Cable Gland	2	17	L20NHVS-30.20.00	Electro Motor Assembly	1
3	L20NSE-30.10.02	Plug on Control Board	1	17.1	L20NHVS -30.20.10	Plug with Cable	1
4	L25XE-30.02.00	Cable with Connector and Plug	1	17.1.1	L20NHVS -30.02.03	Connector	1
4.1	L20NSE-30.02.01	Connector	1	17.1.2	L20NHVS -30.20.12	Cable for Electro Motor	1
4.2	L20NSE -30.02.02	Cable	1	17.2	S203	Electro Motor	1
4.3	L25XE-30.10.01	Connector- Plug	1	18	L20NHVS -30.11.09	Inverter Yaskawa (V1000)	1
5	L20NXE-30.10.00	Metal Box	1	19	L20NS-30.10.04	Potentiometer	1
6	L20NXE-30.11.00	Metal Box Plate	1	20	L32S-30.10.25	Switch On/Off led green Button	1
7	L20NS-30.11.01	Circuit Breaker	4	21	L20NS-30.10.06	Cap	3
7A	L32RSHV-30.00.11	Circuit Breaker	1	22	L20NS-30.10.07	STOP Button	1
8	L20NS-30.11.02	Rail	2	23	L20NS-30.10.08	RUN Button	1
9	L20NXE-30.11.03	Circuit Closer	1	24	L20NS-30.10.10	Emergency Stop Button	1
9.1	WK4U	Terminal	1	25	L20NS-30.10.11	Switch Button F/R	1
10	L20NSE-30.11.07	Transformer	1	26	L20NS-30.10.12	Green LED Power	1
11	L20NS-30.11.04	Relay Base	1	27	L20NS-30.10.13	Water Pump Button	1
12	L20NS-30.11.05	Relay	1	28	L13S-30.10.12	Button alarm/reset blue	1
13	L20NS-30.11.06	Relay Bracket	1	29	L20NS-30.10.15	Revolution counter	1
14	L20NS-30.40.00	Water Pump with Cable	1	30	L20NSE-30.11.01	Filter	1
15	L20NS-30.11.08	Rectifier	1				

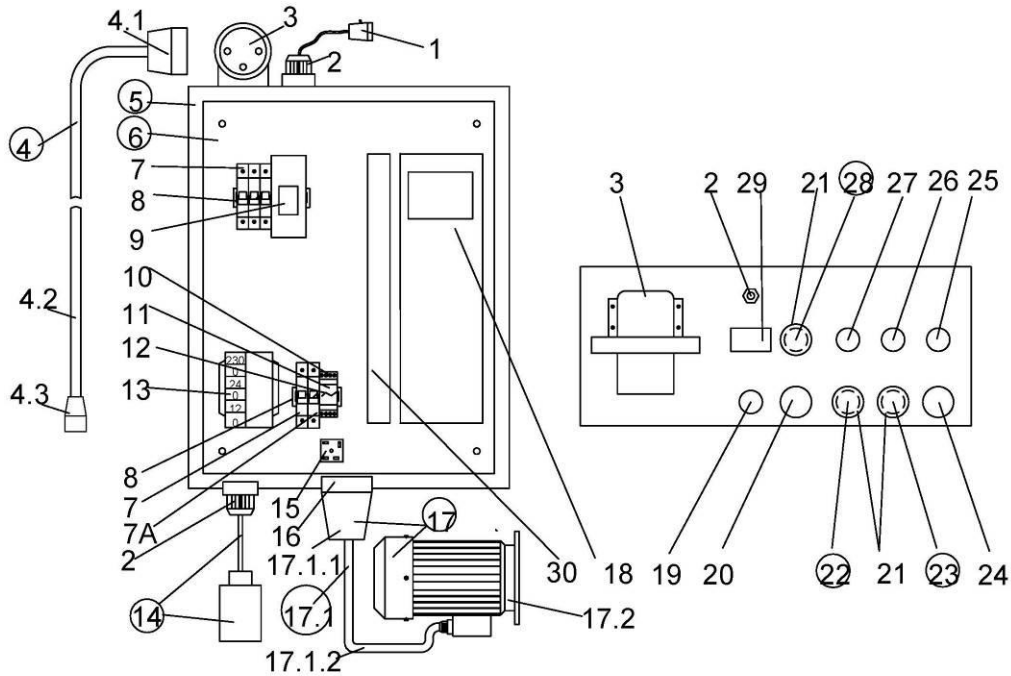

LAVINA® 20N-X-OE CONTROL BOX PARTS 200-240 VOLT							
No.	Item No.	Description	Pcs.	No.	Item No.	Description	Pcs.
1	L20NS-30.30.00	Lamp Unit Incl. Cable	1	16	L20S-30.10.03	Socket	1
2	L20NS-30.10.01	Cable Gland	2	17	L20NSOE-30.20.00	Electro Motor Assembly	1
3	L20S-30.10.02	Plug on Control Board	1	17.1	L20S-30.20.10	Plug with Cable	1
4	L20XE -30.02.00	Cable with Connector and Plug	1	17.1.1	L20S-30.20.01	Connector	1
4.1	L20S-30.02.01	Connector	1	17.1.2	L20S-30.20.12	Cable for Electro Motor	1
4.2	L20S-30.02.02	Cable	1	17.2	S203	Electro Motor	1
4.3	L20XE-30.11.01	Connector- Plug	1	18	L20NS-30.11.09	Inverter Yaskawa (V1000)	1
5	L20NXOE-30.10.00	Metal Box	1	19	L20NS-30.10.04	Potentiometer	1
6	L20NXOE-30.11.00	Metal Box Plate	1	20	L32S-30.10.25	Switch On/Off led green Button	1
7	L20NS-30.11.01	Circuit Breaker	4	21	L20NS-30.10.06	Cap	3
7A	L32RSHV-30.00.11	Circuit Breaker	1	22	L20NS-30.10.07	STOP Button	1
8	L20NS-30.11.02	Rail	2	23	L20NS-30.10.08	RUN Button	1
9	L13X-30.11.01	Contactor	1	24	L20NS-30.10.10	Emergency Stop Button	1
10	L20NS-30.11.04	Relay Base	1	25	L20NS-30.10.11	Switch Button F/R	1
11	L20NS-30.11.05	Relay	1	26	L20NS-30.10.12	Green LED Power	1
12	L20NS-30.11.06	Relay Bracket	1	27	L20NS-30.10.13	Water Pump Button	1
13	L20NS-30.11.07	Transformer	1	28	L13S-30.10.12	Button alarm/reset blue	1
14	L20NS-30.40.00	Water Pump with Cable	1	29	L20NS-30.10.15	Revolution counter	1
15	L20NS-30.11.08	Rectifier	1	30	L20SE-30.11.01	Filter	1