

AUTOSPORT

www.autosport.com • JUNE 11 2015 • £3.70

CANADIAN GP

HAMILTON HITS BACK...



haymarket

9 770269 946265



24 >

C\$8.99

...AS FERRARI BLOWS IT

What happened to upgraded car's pace?

PLUS PLATO'S OULTON PARK BTCC MASTERCLASS



Porsche recommends Mobil 1 and MICHELIN

**Over 30,000 trophies would be in other hands.
If we didn't believe in our ideas.**

Mission: Future Sportscar

The Porsche 919 Hybrid at the FIA World Endurance Championship:

porsche.com/FutureSportscar





PORSCHE



RENAULT
Passion for life

Renault CLIO

Restart your heart



Integrated Touchscreen Navigation

0% APR
representative

From £149 per month

The official fuel consumption figures in mpg (l/100km) for the Renault Clio Dynamique 1.2 16V 75 are: Urban 40.4 (7.0); Extra Urban 60.1 (4.7); Combined 51.4 (5.5). The official CO₂ emissions are 127g/km. EU Directive and Regulation 692/2008 test environment figures. Fuel consumption and CO₂ may vary according to driving styles, road conditions and other factors.

Monthly payment shown based on £2,247 customer deposit with £400 deposit contribution, 36 monthly payments of £149, and an optional final payment of £5,664. Finance provided by RCI Financial Services Limited, PO Box 149, Watford WD17 1FJ. Subject to status, over 18s (excluding the Channel Islands). Terms and conditions apply. Visit renault.co.uk for full details. Offer cannot be used with other offers and is available on featured new vehicles when ordered and registered before 30 September 2015. Offer based on 6,000 miles per annum excess mileage of 8p per mile inc VAT. Participating dealers only. Clio shown has optional Flame Red Renault i.d. metallic paint, available at an additional £595. Excludes Expression models.

POLE POSITION

There's no such thing as an easy F1 victory

WINNING THE CANADIAN GRAND PRIX AT A CIRCUIT HE thrives on while in what unquestionably remains the best car may not sound like much of an achievement for Lewis Hamilton. But given the circumstances, coming off the back of two defeats to Nico Rosberg, this was a race that tested his mental resilience.

What Jackie Stewart, quite rightly, calls 'mind management' is absolutely crucial in elite sports. In the past there have been occasions when Hamilton has shown some signs of frailty, but what he did in Canada was bang on the money. It's never as simple as being the fastest driver in the fastest car, but Hamilton avoided all of the potential pitfalls and errors that can catch out a driver under pressure. And that's much harder than it looks.

This aspect of elite sport is vastly underestimated. Many deride these pressures, usually with an off-hand comment about athletes being paid so much money that they shouldn't have the human frailties that afflict us all. But they're still flesh and blood.

To perform at the top level, under intense scrutiny with the highest of stakes, is never easy. Remember that next time you think that it looks 'easy'.



EDD STRAW EDITOR
 edd.straw@haymarket.com
 @eddstrawF1

COVER STORY

“Nico was quick but I felt like I always had it under control. I had a bit of time in my pocket”

Lewis Hamilton, p16



STALEY/LAT

FIND US ON



Cover images: Moy/XPB; Mason/Getty

PIT & PADDOCK

- 8 THIS WEEK IN F1
- 11 LAWRENCE BARRETTO: IN THE PADDOCK
- 12 THIS WEEK IN MOTORSPORT
- 15 KARUN CHANDHOK: RACER'S EYE

FEATURES AND REPORTS



- 16 CANADIAN GP: REPORTS, NEWS, RESULTS AND TECH
- 32 FORMULA E MOSCOW
- 34 INDYCAR TEXAS
- 36 BTCC OULTON PARK
- 40 TOCA SUPPORTS
- 42 BLANCPAIN SPRINT ZOLDER
- 44 INTERNATIONAL RESULTS ROUND-UP
- 46 WTCC MOSCOW RACEWAY
- 51 EUROPEAN RALLY CHAMPIONSHIP
- 52 NASCAR SPRINT CUP; GT MASTERS
- 54 NICO HULKENBERG AT LE MANS

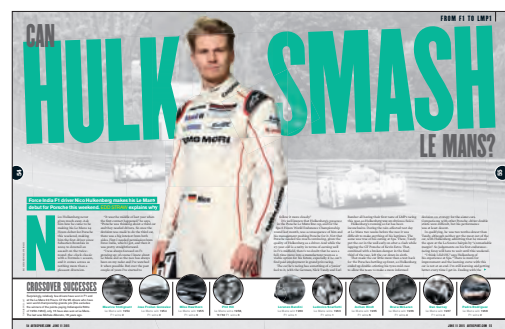

CLUB AUTOSPORT

- 71 WINFIELD SCHOOL REVIVED FOR F4
- 72 KOX TO RACE McLAREN AT SILVERSTONE
- 76 NATIONAL REPORTS
- 84 DRIVING AUTOSPORT 3 HOURS RACERS

THE BACK STRAIGHT

- 90 THIS WEEK
- 92 FROM THE SOFA
- 94 INTRODUCING: MARC MILLER



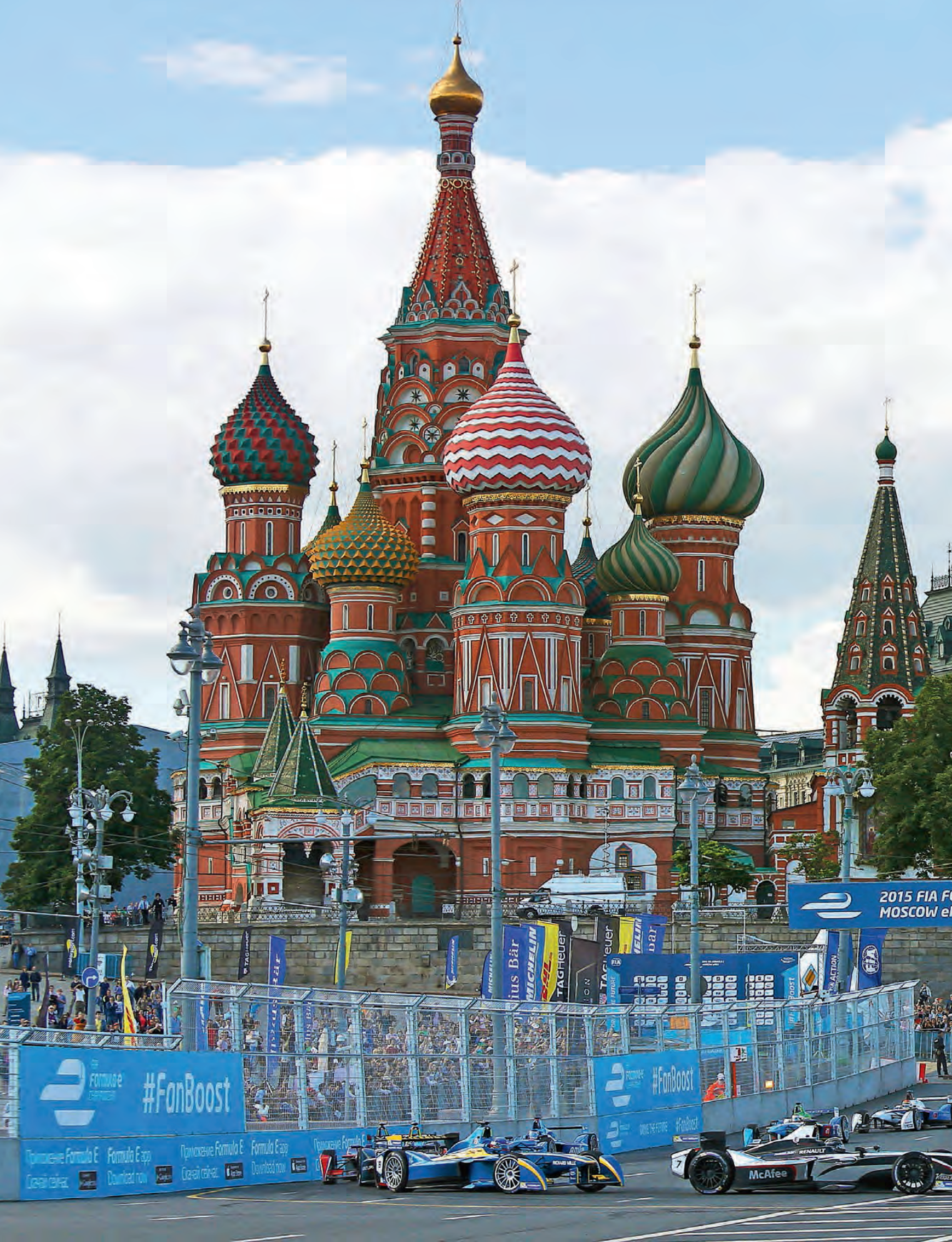

2015 FIA F
MOSCOW e

#FanBoost

#FanBoost

Formula E app Download now

Formula E app Download now

McAfee

THE BIG PICTURE

The FIA Formula E Championship's penultimate round took place in Moscow last weekend. Nelson Piquet's second win extended his points lead ahead of the London finale

Photographer Sam Bloxham/LAT



This week in F1

Cost-cutting saga deepens

BIG F1 TEAMS ACCUSED OF POWER GRAB

Formula 1's independent teams are preparing for a new power battle with the manufacturer squads they believe are trying to take control via customer car rules.

Ferrari, Mercedes, McLaren and Red Bull have been unwilling to make concessions to assist the small teams and are strongly applying weight to the introduction of the customer – or franchise – car concept.

The independents fear the 'gang of four' intends to drive them out and have customer squads wholly reliant on their works partners, and whose revenues from championship positions could go straight into the coffers of the parent team.

Force India deputy team principal Bob Fernley told AUTOSPORT: "The fact there has been absolutely no

movement whatsoever from the four manufacturers to support any form of cost control, the fact they have rejected outright some form of redistribution of income, is telling you they've another agenda.

"That agenda, I believe, is about getting total control from a power and financial point of view.

"I do believe it is a clear power move from those teams."

Sauber team principal Monisha Kaltenborn also voiced concerns over the customer-car scenario.

"It's basically a way, with the commercial interests behind it, for the teams that want to do it, to tap into more income which they otherwise couldn't have," said Kaltenborn. "That is not what the other participants are in here for."



8



Marchionne open to refuelling

Ferrari chairman Sergio Marchionne is open to the return of refuelling to Formula 1 despite resistance from elsewhere.

Team managers met in Canada and determined that refuelling was not conducive to the show.

But Marchionne said: "If the findings are such it provides zero additional spectacle value, in the sense of creating something the fans want, we should stay away.

"Singularly it may not be the answer, but combined with other things it might be, so I am totally open."

It is probably like an aeroplane pilot - they just have to control that everything is working fine



Fernando Alonso likened the process of operating a modern F1 car to that of an aircraft.

Leimer joins Manor as F1 reserve

Manor has signed 2013 GP2 champion Fabio Leimer as its reserve driver.

"It's a huge step for me and I can't wait to get started," he said.

REMEMBER WHEN

NOV 2011



Fabio Leimer already has a day's experience of F1 machinery. In November 2011 he drove for Sauber in the young-driver test.



F1 set to retain 13-inch wheels

Formula 1 appears poised to retain 13-inch wheels despite recent suggestions that it could switch to 18-inch rims.

Mercedes executive technical director Paddy Lowe said: "The broad consensus is that going to bigger wheels is not a good direction. From a grip point of view it's not positive. I think generally we would intend to stick with the 13-inch wheels."

For all the breaking news, visit AUTOSPORT.COM



Merc boss Wolff and Bernie under fire

DUNBAR/LAT



XPB IMAGES

FIA inspects Ferrari tunnel

The Haas F1 team says it is completely comfortable with the legality of its relationship with Ferrari.

The two teams agreed a technical partnership and engine supply deal for 2016, with Haas receiving all non-listed parts from Ferrari as well as using the Scuderia's windtunnel. The FIA recently carried out an inspection of Ferrari's windtunnel, with the governing body satisfied the two teams were operating within the rules rather than Ferrari using Haas-allocated time for its own benefit.

Haas team principal Gunther Steiner (above, with Ferrari's Maurizio Arrivabene) told AUTOSPORT: "There is nothing from our side to hide. And I don't think from Ferrari what they are doing with us is anything to hide."

Revised Force India passes test

Force India's B-spec car is on track to make its debut following this month's Austrian Grand Prix, having passed its crash test.

Deputy team principal Bob Fernley told AUTOSPORT: "We failed the first, but it was pretty marginal. Although it put us back a week or two, it was clear we would get through the second."

"It has now passed all the tests necessary."

BIG NUMBER

44

The number of pole positions Lewis Hamilton has now achieved. That matches his number of wins and puts him one behind Sebastian Vettel, who is third in the all-time list.

9

Pirelli set to get wet-tyre test

Pirelli appears to have secured the wet-weather test it has long called for, with a session likely to take place in February 2016 at Paul Ricard.

It will offer Pirelli the chance to gain valuable data on its wet rubber, in particular the little-used full-wet tyre teams have voiced concerns over.

Pirelli motorsport director Paul Hembery said: "It is something which is being discussed at the moment, but it looks like an early slot next year."

"Everyone will be invited, but the reality is only a small number of teams will actually want to participate."



DUNBAR/LAT



TEEL/LAT

VERSTAPPEN IN FRESH SPAT WITH MASSA

Max Verstappen had a dig at rival Felipe Massa after the Brazilian stood by his criticism of the Toro Rosso driver's Monaco accident.

In the immediate aftermath of Verstappen's collision with Romain Grosjean in Monaco, Massa described the teenage rookie's driving as "pretty dangerous",

adding that "experience counts in F1".

Sitting in the FIA press conference with Massa in Canada, Verstappen responded: "Everybody can have his opinion. The lap on which I crashed [the braking] was exactly the same as the lap before. I got my penalty."

"Maybe you [Massa] should review the [Canadian] race from last year and

see what happened there."

That was reference to Massa's crash with Force India's Sergio Perez in the Canadian GP in 2014.

Massa replied: "It was a little different, no? I was on the side and he [Perez] moved the car under braking." Perez was given a penalty for that incident.



Innovation that excites

AWARD-WINNING FAMILY CAR. HEART-WINNING OFFER.

HAVE IT ALL



NISSAN PULSAR VISIA DIG-T 115
£159 A MONTH

Now with 2 Years' Free Servicing*

0% APR
REPRESENTATIVE

Nissan.co.uk/haveitall

WHATCAR?

Car of the Year 2015

Best family car
Less than £16,000

Pulsar range: URBAN 37.2-68.9mpg (7.6-4.1L/100km), EXTRA URBAN 58.8-85.6mpg (4.8-3.3L/100km), COMBINED 47.9-78.5mpg (5.9-3.6L/100km), CO₂ emissions 138-94g/km.

Offer valid until 30 June 2015 at participating dealers only and subject to vehicle availability. Finance provided by RCI Financial Services Limited, PO Box 149, Watford WD17 1EJ. Subject to status. Guarantees and indemnities may be required. You must be at least 18 and a UK resident (excluding the Isle of Man and Channel Islands). Terms and conditions apply, please visit www.nissan-offers.co.uk/termsandconditions or your local dealer for full details. Model shown is Pulsar Visia at £159 per month with additional metallic paint at £500. Monthly payment based on Pulsar Visia with CUSTOMER DEPOSIT OF £4,272.75 FOLLOWED BY 24 PAYMENTS OF £159 AND OPTIONAL FINAL PAYMENT OF £7,906.25. Offer based on 10,000 miles pa, excess mileage 8p per mile. Offers not available in conjunction with any schemes or other offers. Vehicle price includes first registration fee and 12 months' road fund licence. For terms and conditions relating to Nissan technologies visit www.nissan.co.uk/technologyT&Cs. Always drive carefully and attentively. *Free servicing for 2 years is available when the vehicle is financed through Nissan Finance and servicing must be by a franchised Nissan dealer at specified intervals. Mileage limits from 37,500 apply - please see www.nissan-offers.co.uk/termsandconditions for servicing intervals. MPG figures are obtained from laboratory testing, in accordance with 2004/3/ EC and intended for comparisons between vehicles and may not reflect real driving results. (Optional equipment, maintenance, driving behaviour, road and weather conditions may affect the official results.) Information correct at time of going to print. Model shots shown are for illustration purposes only. Nissan Motor (GB) Ltd, The Rivers Office Park, Denham Way, Rickmansworth, Hertfordshire WD3 9YS.



Lawrence Barretto

From the paddock

What kind of driver is good for F1? Someone who promotes the sport, a self-publicist, a 'character', or simply a great driver?

When Bernie Ecclestone recently said that German Formula 1 stars Nico Rosberg and Sebastian Vettel are “not so good for my business”, because they supposedly don't do enough to promote F1, it raised two interesting questions. Is it in a driver's job description to raise the profile of F1? And if so, what makes up the ideal character to do exactly that?

Vettel argues that it's not his responsibility: “I'm looking after myself and trying to do the best job for myself and the team. That's the highest priority. It's what I'm here to do.” And to a point, he's right. He is paid to be a racing driver and win world titles. It's technically the job of the sport's promoter and the individual race promoters to ‘promote’ F1.

But, conversely, you could say drivers have a responsibility to ensure that the sport that pays their bills thrives, especially if they want to continue making a healthy living out of it.

So who would be the perfect driver to promote F1? Ecclestone thinks it's Lewis Hamilton, a driver who puts himself out there. When he's not in a car, he puts himself in the public eye. You'll likely find him attending a Hollywood party, perched on a TV chat show host's sofa or laying down tracks in the studio.

Hamilton is not only building his brand – and there's no doubt there's a bit of self-interest by doing so –

talent in buckets and popularity is key. Vettel, Rosberg and Daniel Ricciardo have it too, but they don't command the same amount of attention. Ricciardo is everything people should like. He's amusing, always smiling, a nice guy and seriously quick. And yet, he is taking time to build a following.

Raikkonen and his brand of anti-charisma, meanwhile, couldn't be more different, but he's still an icon. When he criticised his Lotus team over the radio in Abu Dhabi 2012, saying “Leave me alone, I know what I'm doing”, people loved it, and the phrase is emblazoned on T-shirts. If Vettel or Hamilton did the same, they would be panned. Unlike the Briton, Raikkonen does not search out attention, but he has the benefit of being different from his rivals and, in a sport where there are fewer ‘characters’, the Finn stands out.

Fallibility is a good thing, as Kamui Kobayashi proved. The Japanese was fast and his bold overtaking moves won him legions of fans. First impressions count too. Juan Pablo Montoya made a name for himself in only his third race with a ballsy move on Michael Schumacher in Brazil. He, too, lacked consistency but was exciting to watch and had the personality to match.

In the early days of Hamilton's F1 career, people struggled to warm to him as he lacked a degree of humility. After crashing into Raikkonen in the pitlane

“When Raikkonen criticised his team over the radio, saying ‘Leave me alone’, people loved it”

but he's also putting F1 on the agenda. Popularity is important to him, too. When he finished runner-up in BBC Sport's Personality of the Year in 2007 and '08, he was hurt. Seeing him clutching the trophy after his third nomination in 2014, his eyes welling up, showed how much having the public's respect means to him. Vettel isn't like that. He prefers to steer clear of talking about his private life and to remain largely anonymous when away from the circuit.

Character is clearly crucial. Take Jamaican sprinter Usain Bolt. He is box office. You could go as far as to say that he is single-handedly keeping interest in track and field alive. Minutes before the start of a 100m race, when rivals are “getting in the zone”, Bolt is messing around, playing up to the cameras and striking that pose. Then he gets down onto his blocks and wins. F1 doesn't quite have the equivalent.

Talent is important but not enough on its own. Hamilton, Fernando Alonso and Kimi Raikkonen have

during the 2008 Canadian Grand Prix, having failed to see the red light, Hamilton refused to admit that he had made a mistake.

Had he just said it was an embarrassing error and laughed it off, he would have come across more favourably. But that was seven years ago, and with time come maturity and experience. Hamilton is very much more his own man now and that is evident in the way he handles himself in public. So perhaps it takes time to be a good promoter.

There is no doubt that F1 needs more drivers who are “good for business” but, while it will be beneficial for themselves in terms of their legacy and financial stability for life after F1, it should be their choice rather than their responsibility.

As for the ideal F1 promoter, clearly, there's no magic formula, but a driver who is talented, honest, experienced and unique can't go far wrong – and then it's down to the public to decide. ❧

This week in motorsport



TOYOTA EYES NEW DIRECTION – AND EVEN TURBO – FOR LMP1 CAR

Toyota is evaluating all aspects of its technical package for 2016 after admitting that it has been leapfrogged by rivals Audi and Porsche in this year's World Endurance Championship.

Toyota Motorsport GmbH technical director Pascal

Vasselon has revealed that the energy-retrieval systems and storage unit, as well as the normally-aspirated engine that powers the latest TSO40 HYBRID, were all under review.

"We are examining what we do next year, because we need a plan," he said. What we can say is that under

normal conditions, a normally-aspirated engine is reasonably competitive. But a turbo has a wider window and can react to all conditions, such as high altitude and hotter temperatures."

Toyota was known to have considered swapping from its

super-capacitor energy-storage system to a battery for this season.

Vasselon conceded that the two Toyota TSO40s "will not be the fastest" cars at this weekend's Le Mans 24 Hours. He said the team would be "going for a strategy based on maximum reliability".

12

Kiss chases WRX success

Last year's Auto GP runner-up Tamas Pal Kiss will make his World Rallycross debut this month at the Estering round.

Kiss, who hails from a rallycross family and started his career in the sport, will race the Skoda Fabia with which he is contesting the Hungarian series. He is eyeing a full-time WRX switch by 2017.

REMEMBER WHEN

2010



Tamas Pal Kiss was a Formula Renault UK frontrunner? He beat Will Stevens, Harry Tincknell and Alex Lynn – among others – in a series won by Tom Blomqvist.



FR3.5 DROPS LDF AERO

The Formula Renault 3.5 series has dropped its low-downforce aero format after just two races.

The LDF was introduced for 2015 and made mandatory for Saturday races. Teams will now have a free choice of aero during Saturday races, as is the case for Sunday pitstop races.

The future of LDF in the series had

come under scrutiny following Draco driver Pietro Fantin's accident during Friday practice at Spa a fortnight ago.

Although it was uncertain that LDF caused the crash, a subsequent vote in the drivers' briefing indicated that the majority of drivers preferred the LDF rules to be dropped following the Belgian round.

Priaulx to skip Rockingham

Andy Priaulx has confirmed that he is set to miss September's Rockingham round of the British Touring Car Championship in favour of contesting the penultimate European Le Mans Series event.

Priaulx is 11th in the points after a trying Oulton Park weekend and the factory BMW driver is almost certain he will contest the clashing ELMS round at Paul Ricard instead.

AUTOSPORT understands that the WSR team is already considering potential replacements. The BTCC's one-driver-change rule does not apply to substitutes.



P36 OULTON BTCC ACTION

For all the breaking news, visit **AUTOSPORT.COM**

Murray leads TVR design

Formula 1 design legend Gordon Murray's organisation is developing the new range of TVR sports cars set to take the British marque back to the Le Mans 24 Hours.

TVR, bought in 2013 by a group led by gaming entrepreneur Les Edgar, has firmed up its plans for two new models.

The cars, developed by Gordon Murray Design, will be powered by Cosworth V8 engines.



Race rookie's Le Mans 24 seat

Frenchman Gaetan Paletou will make his Le Mans 24 Hours debut this weekend – just 10 months and 18 races after winning last year's Nissan GT Academy.

Gamer-to-racer Paletou has been placed by Nissan with the British Greaves Motorsport LMP2 squad for the World Endurance Championship blue riband after taking part in the official Test Day earlier this month.

The 22-year-old will take the seat of Swede Bjorn Wirdheim, who has agreed to step down for Le Mans, alongside Jon Lancaster and Gary Hirsch in the Greaves Gibson-Nissan O15S.



In brief



KUMPEN IN XFINITY

Reigning Euro NASCAR champion Anthony Kumpen is to contest three rounds of the stock-car sanctioning body's second-tier Xfinity Series. The Belgian (#24, above) – the uncle of Max Verstappen – will race at Iowa Speedway on August 1, as well as the Phoenix and Homestead rounds in November as part of the Road to Daytona programme. He gets a warm-up by competing in a K&N Pro round at New Hampshire Motor Speedway on July 17.

BAMBOO IN ASIA

Leading TCR International team Craft Bamboo Racing has expanded its programme to include the TCR Asia series. The Hong Kong team uses SEAT Leons. TCR Asia kicks off at Zhuhai on August 14-16.

BAYNE ON PROBATION

NASCAR Sprint Cup racer Trevor Bayne has been fined \$20,000 and placed on probation until the end of the season for walking across the track in the recent Dover round after a crash. The practise was prohibited after the death of sprint-car driver Kevin Ward Jr last summer.

PENALTY REDUCED

IndyCar star Helio Castroneves has had his points penalty from last month's Indianapolis road-course race reduced from eight to three. The Brazilian was punished for his collision with Scott Dixon at Turn 1 on the opening lap.

SAAVEDRA RETURNS

Chip Ganassi Racing's #8 entry in the IndyCar Series will get another driver switch for Toronto this weekend, with Sebastian Saavedra (below) again replacing Sage Karam.



GREAT ORME, MYHERIN BACK IN RALLY GB

The Great Orme and Myherin stages are the returning highlights of the Rally GB route, revealed this week.

The Thursday November 12 start of the event moves from Eirias Park in Colwyn Bay to Llandudno, while the

finish (November 15) shifts to Deeside, ensuring the service park remains open to the public on all four days.

Friday remains the southernmost stages in mid-Wales, including Myherin, while Saturday is lengthened to 18 hours

and three loops, the last of which will be run in the dark.

Brenig is used twice on the final day – separated by the Great Orme stage – with the second run acting as the event's powerstage.

Piquet joins Carlin for Indy Lights

Formula E Championship leader Nelson Piquet Jr will stand in for Le Mans 24 Hours-committed Max Chilton at Carlin's Indy Lights team this weekend in Toronto.

Ex-Renault Formula 1 driver Piquet will join Carlin regular Ed Jones at the squad.

Although Piquet has raced in all three tiers of NASCAR as well as being a star in the US-based Global Rallycross series, this will be the Brazilian's first taste of an American open-wheel category.

Team boss Trevor Carlin said: "We've



known Nelson since his British Formula 3 days, and he's shown in Formula E he's a master of street circuits."

Have fun dude. That track looks amazing



Dale Earnhardt Jr. tweeted to cousin Jeffrey Earnhardt, who took a best of seventh in the Brands Hatch Indy circuit round of Euro NASCAR last weekend

Kuala Lumpur V8 street race

A new street circuit in Malaysian capital Kuala Lumpur will host its first event this August, before Australia's V8 Supercars category headlines in a four-year deal from 2016-19.

The two-mile track will operate with the assistance of management from the nearby Sepang Formula 1 circuit, and this year hosts a regional cocktail of Asian GT, Audi R8 LMS Cup, Asian Carrera Cup, Lamborghini Super Trofeo and Formula Masters China.

The 2015 event will also feature a V8 Supercars demonstration run – featuring cars from all five makes – before they take centre stage next year.

ASTON GOES ABSTRACT

This is the abstract colour scheme in which the lead Aston Martin Vantage GTE will race in this weekend's Le Mans 24 Hours. The art-car livery on the #97 is the work of German artist Tobias Rehberger.



2015 FORMULA 1
SINGAPORE AIRLINES
SINGAPORE GRAND PRIX



TICKETS
NOW ON SALE
18.19.20 SEPTEMBER 2015 SINGAPORE
MARINA BAY STREET CIRCUIT

3 DAYS OF NON-STOP RACE ACTION

FIA FORMULA ONE
WORLD CHAMPIONSHIP

PORSCHE
CARRERA
CUP ASIA



ALSO FEATURING
WORLD-CLASS
ENTERTAINMENT

PHARRELL WILLIAMS
18 SEP FRIDAY ZONE 4 PADANG STAGE

MAROON 5
19 SEP SATURDAY ZONE 4 PADANG STAGE

SPANDAU BALLET
19 SEP SATURDAY ZONE 1 VILLAGE STAGE

MORE ARTISTES TO BE ANNOUNCED

OFFICIAL WEBSITE WWW.SINGAPOREGP.SG

AVAILABLE THROUGH ALL AUTHORISED TICKETING PARTNERS

FOR HOSPITALITY ENQUIRIES
+65 6731 5900

HOSPITALITY@SINGAPOREGP.SG

TITLE SPONSOR



The F1 FORMULA 1 logo, F1, FORMULA 1, FIA FORMULA ONE WORLD CHAMPIONSHIP, GRAND PRIX and SINGAPORE GRAND PRIX and related marks are trademarks of Formula One Licensing BV, a Formula One group company. All rights reserved.

Artiste line-up subject to change



Karun Chandhok

The racer's eye

DRS has its place, but perhaps it's time to reconsider whether it should be used at all tracks or just a select few

The Canadian Grand Prix this weekend wasn't the most exciting race we've seen at the Circuit Gilles Villeneuve. For a track that has produced some of the most dramatic races in recent Formula 1 history, it certainly wasn't a classic. Who can forget Nigel Mansell's surprise retirement on the final lap in 1991; the crashes into the wall of champions by Michael Schumacher, Jacques Villeneuve and Damon Hill in 1999; the superb intra-family battle between Michael and Ralf in the early 2000s, not to mention the brilliant races in 2010 and 2011; and even last year, which turned out to be one of the best of the season?

The surface at this circuit is unique, perhaps conditioned in a peculiar way by the extreme winters that they have in Montreal. Having married a Canadian, I've visited there in the winter when it was -35C! The tyres never truly dig in to the track surface and they just seem to just slide on the top. This is nothing specific to the current Pirelli era, for it was also a feature in the Bridgestone days. In fact, if you remember, the 2010 race was the one Bernie often mentioned as the reference point for what he wanted Pirelli to produce!

All of this means that the Canadian GP is a difficult challenge for the teams and drivers – in effect you have a low-grip street circuit where cars are running low downforce. You also have to consider that there aren't really that many corners – because, if you think about it, most of the corners are a combination of right-left or



The circuit is also good for overtaking and I have to say it's one of those where I would think about abandoning the DRS zones. Overtaking at the Circuit Gilles Villeneuve used to happen even in pre-DRS F1, but the moves were hard-fought and on the edge. Now, while we saw a few close battles, I thought the closing speeds of the car behind when the DRS was open were a bit excessive. When Fernando defended against

“There's a balance between making a good show and making it look silly; we were over the line”

left-right in quick succession, so when you look at the telemetry data traces, you actually only see seven corners. This often means that the times are very close and really the pecking order is determined by horsepower. All of a sudden Williams, Force India and Lotus come to the fore and the likes of Daniel Ricciardo and Red Bull have a complete shocker.

Picking a braking point is very tricky indeed, especially since the references around the track aren't brilliant. Being a few metres too early will cost you big chunks of laptime at 205mph, and being a few metres late will mess your line up. You really have to be spot on with your turn-in to all the chicanes and then really thread the eye of the needle to get the line right. The angles at which you attack the kerb are critical not just to speed, but also to not spitting you off into the wall. Watching Lewis Hamilton and Fernando Alonso, you could see the drivers who had the confidence to attack on turn-in. Felipe Massa was also good, I thought, particularly at the last chicane.

Sebastian Vettel into the final chicane but then got passed easily on the start-finish straight with DRS, it was a bit too easy for Sebastian.

I really believe that the FIA should think about whether F1 needs DRS at all tracks. Places such as Montreal, Spa and Interlagos have always been good for overtaking, so they should have the option of getting rid of DRS at these places and making it harder for the drivers. There's a fine balance between making a good show and making it look silly; and in this case I think we were a bit over the line. Circuits such as Barcelona and Hungary certainly benefit from DRS because the races used to be complete snoozefests, but I think the drivers should perhaps work with Charlie Whiting and go through the calendar and pick a few races from which to remove DRS as a test.

Don't forget, in the Pirelli era, overtaking has become more frequent anyway with the tyre-wear factor, and DRS was conceptualised in the Bridgestone era of tyres that would last forever. ❧

HAMILTON BACK ON TOP IN MONTREAL

Lewis Hamilton nursed his Mercedes home to put the pain of Monaco behind him and take his fourth victory at Canada's Circuit Gilles Villeneuve, as **BEN ANDERSON** explains





Hamilton was once
again difficult to catch



DUNBAR/LAT

18

THE RACE 14:00, 07.06.2015



The Canadian Grand Prix was a big race for the Ferrari Formula 1 team. The Scuderia has received widespread praise for closing the monstrously large deficit to Mercedes from last season, and becoming the nearest challenger to the Silver Arrows this year.

But the momentum built up over the first four races of the campaign, which included an unexpected victory for Sebastian Vettel in Malaysia and a near-win for Kimi Raikkonen against the brake-by-wire-less Mercedes in Bahrain, has

stuttered since May's Spanish Grand Prix, where Ferrari brought a substantial aerodynamic upgrade to the SF15-T but was well beaten by Nico Rosberg and Lewis Hamilton in the end.

Ferrari looked in better shape in Monaco, where pure power is less important than most tracks. Vettel was able to take advantage of Mercedes' strategic blunder under the safety car to steal an unlikely second place. Even so, Hamilton and Rosberg would have finished one-two comfortably but for Hamilton's unnecessary late stop.

The Mercedes team has produced by far the best power unit under F1's current V6 hybrid turbo regulations, using superb fuel efficiency and energy recovery to allow it to run more downforce (where it's also performing strongly in terms of development) than its rivals.

But Ferrari has already made significant improvements over the winter to what was a woefully underpowered, overweight and inefficient 2014 power unit, and brought upgraded internal-combustion engines to Canada in the hope of closing the gap further.

After limited running in Friday practice there were some encouraging signs. Vettel lapped his Ferrari 0.316 seconds slower than Hamilton's Mercedes, with Raikkonen just behind – the nearest the Scuderia has managed to get at that stage of a race weekend all season.

But variance of fuel loads and engine settings always makes Fridays difficult to read; only on Saturday afternoons, when the fuel comes out and the engines get turned up to full whack, do we truly get to see what tools the drivers have to play with.

But on this occasion we didn't – in Ferrari's case, at least. Vettel was hampered by an ECU problem on his car, which robbed the engine of power and meant he failed to escape Q1, qualifying only 16th fastest and relegated to 18th by a penalty for overtaking under red flags in the final practice session.

The four-time world champion has usually comfortably been the fastest Ferrari driver on



Ferrari boss Marchionne
was watching progress

XPB IMAGES

Vettel was dejected after qualifying...



Massa and Ericsson lock wheels



...but battled up to fifth from 18th



Saturdays so far this season, outqualifying Raikkonen by an average of 0.473s in races where they've both made the top-10 shootout (so everywhere bar Malaysia, where Raikkonen dropped out in a rain-affected Q2).

Ferrari team principal Maurizio Arrivabene had urged Raikkonen to improve his qualifying form after Monaco, and the 2007 champion duly qualified third fastest in Canada, 0.621s adrift of Hamilton's pole time.

Vettel's average qualifying deficit to the fastest Mercedes in dry qualifying sessions this season is 0.855s, so the fact that Raikkonen was two tenths closer than that average suggests Ferrari has closed the gap. If Vettel had enjoyed a clean qualifying session and participated in Q3, it's also reasonable to assume he would have been closer still – perhaps even able to split the Mercedes drivers, given Rosberg lost his way on set-up, as he had when Vettel beat him to second on the Bahrain grid.

If Vettel had started second, the Canadian Grand Prix might have turned out to be a tense thriller, rather than the fairly monotonous Mercedes formation finish at the front that it was. Even the final margin of over 40s that winner Hamilton held over the third-placed Williams of Valtteri Bottas was exaggerated by Raikkonen's unfortunate torque-map-induced burnout spin at the hairpin.

Without that costly moment, which the team could not be sure was down to an incorrect setting or a problem with the throttle map itself, Raikkonen

Raikkonen: "We were hoping for a bit more of a closer fight but this circuit shows you if you're lacking something"

would have finished on the podium. He was 4.5s clear of Bottas before he pitted on lap 26 and trailed Hamilton by less than 11s. That means Raikkonen's average pace deficit to the leading Mercedes over the first part of the race was 0.423s per lap.

You could argue he would have been closer still but for the need to fuel-save "quite a bit", as he put it, but Hamilton also spent much of his race saving fuel, to ward off a potential attack from Rosberg in the closing stages.

It's probably fair to say that, on balance, Ferrari did take a step closer to Mercedes in Canada – we just didn't get to see the full extent of that stride. "We were hoping for a bit more of a closer fight and better result against them, but I think this circuit is going to show you the difference if you're lacking on something," said Raikkonen, who knows only too well how bad last year's Ferrari was.

"I'm sure the upgrade was good and worked as expected, but obviously we still have to work hard and improve things overall. I'm sure when we go to more normal circuits we will be stronger and we'll ▶

Hamilton led all the way



► know where the differences were. The car is actually pretty nice. We had to fuel-save quite a bit, so that was a bit limiting today, but it's all those things, not just the one.

"We have come a very long way since last year, like we see from the results, but we still have a way to go, and I'm sure this circuit layout is one of the most difficult for us in the aspect where we are lacking a bit.

"Obviously if you put more downforce in the car and put more power it's the easiest way, but it's not the easiest [task] to improve the cars, otherwise everyone would be able to do it, so we just have to keep working the same way we've been doing so far.

"I'm sure we'll get there, but we need more time, and I'm sure from circuit to circuit it depends where we are against Mercedes."

Vettel started 18th on the grid, on account of his penalty, but recovered to finish just 4.278s behind Raikkonen in fifth. The German lost time at his first pitstop and also suffered a couple of close shaves with Fernando Alonso's McLaren and Nico Hulkenberg's Force India at the final chicane. But the fact that he was put on an aggressive two-stop strategy to help him progress through the field renders a race comparison to the Mercedes drivers redundant in reality.

But could he have realistically challenged them with a clean weekend in Montreal? "In the end we didn't [have one], so we will never find out," he said. "I think from our side everything worked

Arrivabene: "It's a long way to go. We have to have a bit of humility to recognise Mercedes are stronger than us now"

as expected. Surely you cannot expect miracles. Look at the gap in pre-season testing – it was huge. Since then I think we were able to close, some races more, some races less.

"It's not that easy. They are not idiots and they are also trying to make as much progress as possible. So if you close the gap it means you have to make more progress, which is not so easy.

"So far I think we are on the right track and things are going the right way."

Arrivabene too insisted his team had made strides forward here, claiming circumstances had prevented Ferrari making the most of an engine upgrade that he said was delivering everything the Scuderia expected it to.

"If you look at the pace of Seb during the race it's quite clear that in terms of timings we were there," he argued. "In terms of performance it's fine. The engine upgrade was giving us the positive answer we were asking for; unfortunately, the weekend was not a good weekend because of a number of circumstances, but the response we have from the engine was good.

"It's a long way to go. We have to have a bit of humility to recognise they [Mercedes] are stronger than us at the moment, without thinking we have closed the gap so we can beat them every race. This is not realistic.

"If you're asking me if I'm happy, no, I'm not happy. This weekend was not a good weekend."

The nature of the Circuit Gilles Villeneuve places high demands on braking stability and traction, as well as pure power, so it's possible that Ferrari has made a big gain in terms of horsepower, but still



Raikkonen was heading for podium before spin

lacks a little in the other areas necessary to be fast here. Mercedes boss Toto Wolff could ultimately celebrate a comfortable one-two finish for his drivers, but he also reckoned the potential of Ferrari's upgraded package was masked by Vettel's Saturday difficulties and Raikkonen's spin.

"I think we must not underestimate the upgrade they have brought because we've seen a very strong pace on the Friday," he argued. "Maybe these bits haven't made it onto the car or the engine with the mapping they wanted to run, so my assumption without really knowing it is we haven't seen the best of Ferrari today.

"Sebastian had a very difficult Saturday and started from the very back. He had a messy race with Hulkenberg and ran into backmarker traffic, and Kimi obviously spun. I think they will bounce back strongly [next time out] in Austria."

Watching Ferrari chairman Sergio Marchionne will certainly hope so, having flown into Montreal to see his scarlet chargers finish a distant fourth and fifth. But Ferrari can also take encouragement from the difficulties Mercedes endured at the front.

It sounds almost daft to say it when the team has just enjoyed another dominant one-two result, but Mercedes is now being forced to run fast enough that its drivers can run into trouble more easily.

We saw a glimpse of it in Bahrain, when both cars encountered problems with their brake-by-wire systems, and in Canada both Hamilton and Rosberg had to take care with their cars to get to the finish in good order.



Hamilton nursed his tyres and fuel to the flag

Rosberg's brakes were "in danger after the first third of the race", according to Wolff, which stymied his hopes of attacking Hamilton's lights-to-flag winning position at the end, while Hamilton was told repeatedly to save fuel throughout the race. This is perhaps a sign that Mercedes is now pushing its cars far harder than in the past, in order to remain ahead.

But it's also fair to say the Mercedes drivers are also racing hard at the front in an effort to beat each other. Hamilton was in peerless form again in qualifying (despite a messy build-up, which included shunting in the rain in practice two and flat-spotting two sets of tyres in final practice),

QUALIFYING



Sometimes in sport it's difficult to know whether to stick or twist, especially when things aren't going your way and there is pressure to deliver. With hindsight, Nico Rosberg should have stayed calm, stayed relaxed, and stuck with the set-up he had on his Mercedes W06.

But his first run in Q3 hadn't gone well. He was three tenths slower than team-mate Lewis Hamilton, and fractionally slower than his own previous best effort in Q2.

Rosberg was unhappy with the amount of rear grip he was feeling and complained to the team. Mercedes told him not to worry, and said his next set of super-soft Pirelli tyres (according to detailed analysis) would be better.

But Rosberg wasn't convinced, and wanted to alter front-wing settings for the final run, taking some downforce off the front of the car to balance out the oversteer. Mercedes wanted him to stick with the set-up he had. Rosberg had the final say and made the change.

The result? Too much understeer on the next set of tyres and a laptime another 0.133s slower than his earlier effort. Pole to Hamilton – for the 44th time in his career, and the sixth time in seven races this season.

"It was just chasing your tail in the end, and it went all wrong," explained Rosberg. "It was a call I had to make to change the set-up, because you never know [if] the grip might come back, but for the last set the grip was back to normal and then I just had too much understeer, because I had adapted to the first set.

"They were a bad set. It's amazing how things go. Tiny things in the end make such a big difference and it got me today. Everything just has to come together to get pole in F1 – it's such a fine line."

Perversely, Hamilton's poor run through final free practice (where he flat-spotted two sets of tyres under braking and recorded the slowest timed lap of the session) simplified the reigning champion's strategy.

After completing just nine (useless) laps in the third practice session, he felt he had no choice but to leave the car as it was and just drive heading into qualifying.

That's what he does best, of course, and his first run in Q3 was easily good enough for pole in the end. But for an oversteer moment in Turn 2 on his second run (which he estimated cost him two tenths) he might have been fractionally faster still.

"I even surprised myself just how quick I got back to it," he said. "I just took it one step at a time. We did a longer first run in Q1, which enabled me to get back onto it, and it was relatively easy to be honest."



MASON/BETTY



TEE/LAT

Brit claimed his fourth Canadian GP trophy...



XPB/IMAGES

...while Rosberg has yet to win the race at all

and that's where he won this race. Rosberg lost his way with his car's set-up on a rogue set of tyres at the start of Q3, qualified second, and, once Hamilton had aced the start and led into Turns 1 and 2, that was pretty much that.

The soft and super-soft tyre compounds – which Pirelli has made harder this year in order to make them available at more circuits – were also not degrading much on a circuit where tyre management normally plays a big part.

This means the cars can run closer to full pace for longer (allowing for brakes and fuel management, of course) and thus stretches the gaps between cars that are inherently quicker than others.

Beware those who reckon more durable rubber would make for better racing...

It would be easy to claim that the Canadian Grand Prix – usually one of the calendar's more exciting races – was dulled this year because of the way the category is specified right now.

But a combination of low tyre degradation, conditions and the lack of safety-car periods (usually common on this type of circuit) were more significant factors this time. As was the fact that Mercedes still clearly has the fastest package on the grid, despite Ferrari's best efforts.

It will take more than one combustion-engine upgrade to turn that situation around. ❧



ETHERINGTON/LAT

Hamilton was happy with his Q3 run

HOW THE RACE WAS WON

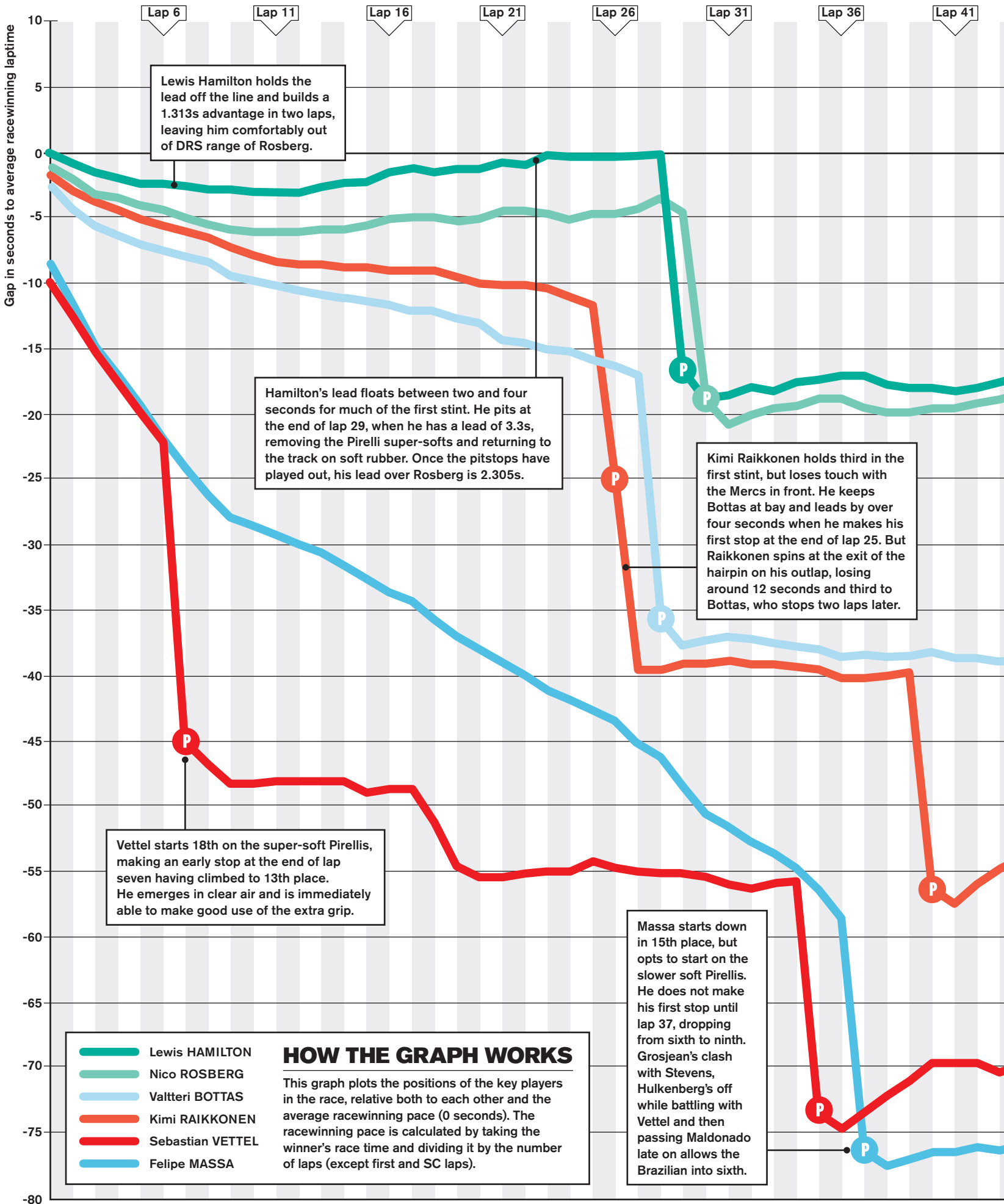

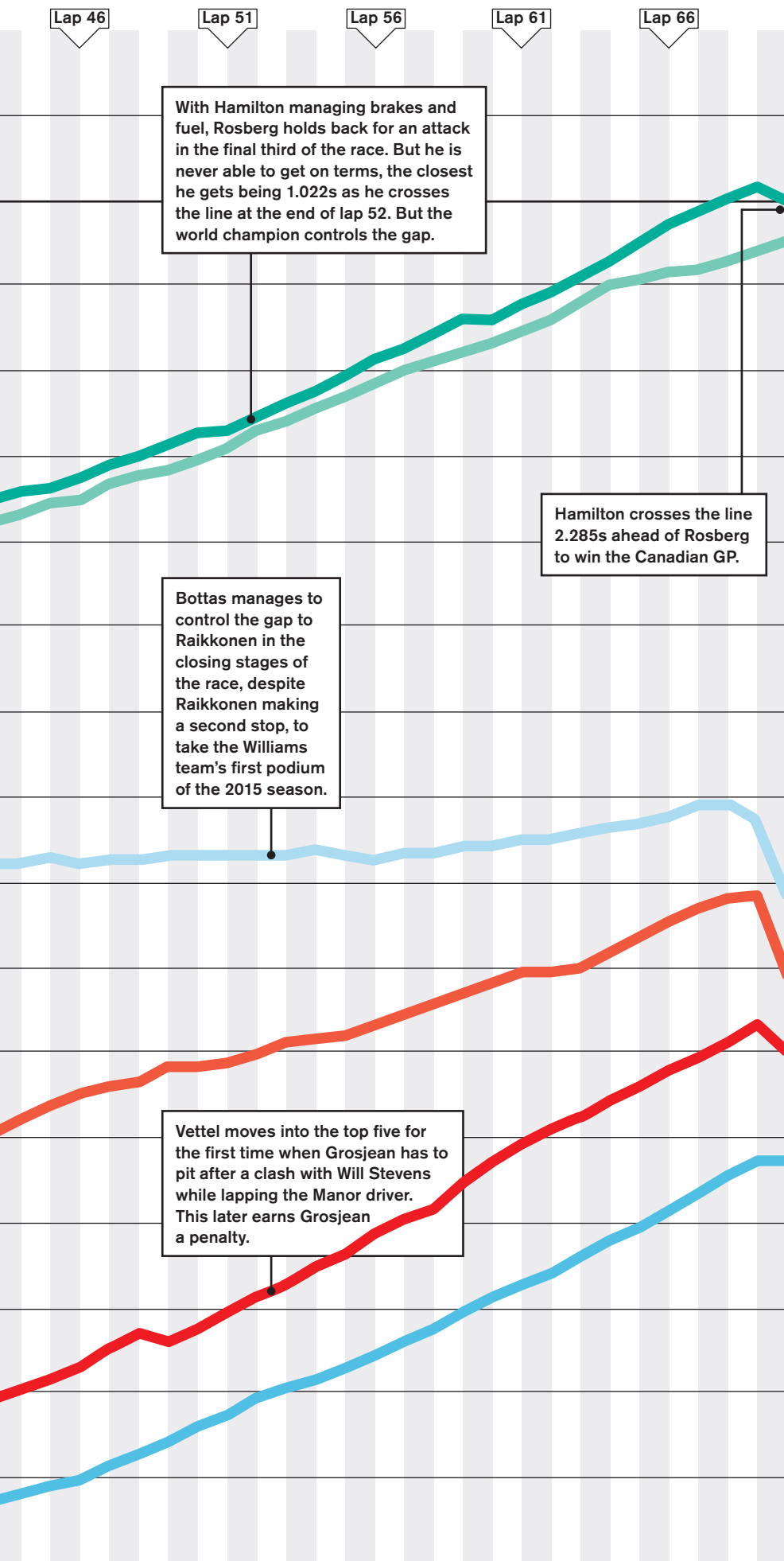

TRACKSIDE VIEW

BEN ANDERSON
GRAND PRIX EDITOR

ben.anderson@haymarket.com

@BenAndersonAuto

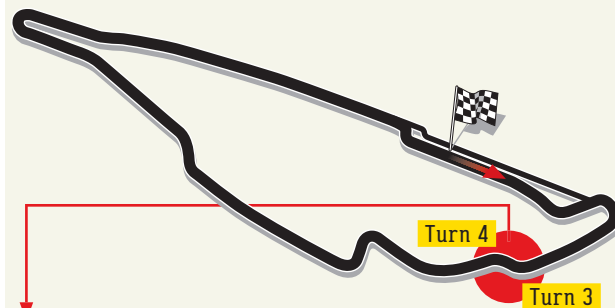

Trudging through the woodland that lines the lake around the Circuit Gilles Villeneuve is a unique experience. On one side you have the new-age roar – purr/whoosh? – of V6 turbo Formula 1 engines, on the other you have groundhogs scurrying about the undergrowth near the water's edge, and an angry mother bird swooping at you from low-hanging branches as she tries to defend her nest!

Once you've survived the aerial attacks you reach Turns 3 and 4, which affords the opportunity to see the drivers attacking a tricky medium-speed chicane. To be effective through here requires good braking stability, precise turn-in, enough compliance in the suspension to ride the kerbs, plus a decent dollop of traction to fire your car onto the straight that follows. The outside wall is close and unforgiving here, so confidence is king...

One driver oozing confidence through here is Romain Grosjean, clearly delighting in the handling characteristics of a much-improved Lotus.

Last season he was all acrobatics at the wheel of the twin-tusk E22, as he battled with understeer and the resulting snap-oversteer; this season his movements are confident, controlled and not overly aggressive.

"Last year Grosjean was all acrobatics, this year confident and controlled"

Grosjean has insisted since pre-season testing that the Mercedes-engined E23 is a completely different story.

"Last year we had the problem of inconsistency," he says. This year going into the corners was actually quite enjoyable and straight away I had a really good feeling. It is much more consistent and you don't lose the downforce. You can attack more. You can slide a little bit and know if you back off the throttle the car is going to stop sliding."

The reward for this new-found confidence is third fastest time in first free practice, behind the all-conquering Mercedes. No more Groundhog Day for Grosjean it seems.



Grosjean was best of the rest in practice

STORIES OF THE RACE



XPB IMAGES

24

Upgraded McLaren-Honda suffers double-retirement disaster

McLaren racing director Eric Boullier called on Honda to collaborate more closely with his team in order to improve its form after a disastrous Canadian Grand Prix for the partnership.

Honda brought an upgraded engine to Montreal, believed to include revisions to the turbo/MGU-H system on the power unit. Honda boss Yasuhisa Arai declared that his company was buoyed by progress with the engine after Friday practice, but engine changes were subsequently required on both cars.

Honda discovered a fault with Fernando Alonso's unit and changed it before FP3, while Jenson Button's ERS failed in that session and the Brit subsequently missed qualifying while his engine was changed.

Honda also had to replace Button's turbo and MGU-H before the race, which meant he had to serve

a drivethrough penalty early on, after starting last.

Both cars were uncompetitive, before retiring with unrelated exhaust problems.

McLaren has already used its internal KERS expertise to help solve a pre-season MGU-K problem with the Honda engine, and Boullier suggested similar collaboration is required to solve this latest crisis. "We [McLaren] keep talking about issues, and obviously we hope to be listened to more [by Honda]," said Boullier. "They do listen. We have discussions every day. I don't want to go into anything in public.

"Of course, it is easy to blame the partner, but as a partner we also have to be supportive. We need to help them to accelerate this recovery. We have some software, IT, whatever it is, we have this experience at home, so McLaren can actually offer Honda support in

this domain to help them shift resources."

Aware of how Red Bull and Renault have pointed accusing fingers in public given the Renault's difficulties since the introduction of the V6 engine rules, Boullier is determined not to follow a similar path. "It's important Honda recover," he added. "I guess it's not embarrassing now, because they are new into the programme, but it's a question of how fast they recover.

"It is hard not to blame. It is a management exercise, and we don't want to be like Renault and Red Bull, fighting in the media. There is no sense in that.

"There is a proper reason why we moved to Honda," Boullier added, "and we are happy with the move, even if it is frustrating now. Yes, it's painful, yes it's maybe embarrassing, but this is Formula 1, where the technology is huge and complex."

McLAREN-HONDA'S 2015 FINISHING RECORD

Magnussen's car



Button's car

AUSTRALIA

Kevin Magnussen suffers engine failure on his out-lap to the grid, though Button finishes 11th.



Alonso's car



Button's car

MALAYSIA

Both cars retire from the race, one with a turbo problem and the other with an ERS cooling leak.



Alonso's car



Button's car

CHINA

Alonso suffers an ignition problem in FP3, but both cars make the finish.



Alonso's car



Button's car

BAHRAIN

Button's car breaks down in two of the three practice sessions and at the start of qualifying with various electrical problems, which also force him out before the start of the race. Alonso finishes 11th.

Alonso's car



Button's car

SPAIN

Honda's engine runs reliably but Alonso retires with overheating rear brakes thanks to an errant visor tear-off. Button finishes 16th.



Alonso's car



Button's car

MONACO

Button scores the team's first points of 2015 by finishing eighth, but Alonso retires with an overheating gearbox.



Alonso's car



Button's car

CANADA

Both cars retire with exhaust trouble in the race, after engine woes in practice, which force Button to miss qualifying again.





Alonso: I was made to look amateur

Fernando Alonso believes he was made to look like “an amateur driver” during a Canadian Grand Prix weekend to forget for McLaren-Honda.

Alonso appeared to let frustration get the better of him when told over the radio after just 24 laps to save fuel, responding by saying: “I don’t want! I don’t want!”

The double world champion added: “Already I have big problems now. Driving with this, looking like an amateur. So I race and then I concentrate on fuel.”

Alonso later retired for the third consecutive race, for the first time since his debut season with Minardi in 2001, with an exhaust problem.

Explaining his apparent rant, Alonso insisted there was “no frustration” adding: “It was just a disagreement on when to save fuel. Different parts of a race require different techniques of driving, so when you are in the middle of a battle, fuel is a low priority in that moment.”

Given the MP4-30’s pace deficit on a power-dependent circuit, there were times when Alonso could only defend for a short period before being passed, resulting in his “amateur” jibe.

“You are fighting and then you get to a group of cars where some people catch you and they are faster than you,” he said. “You look like an amateur driver and that’s not good.”



Raikkonen blames torque map for spin

Kimi Raikkonen blamed a problem with his Ferrari’s torque maps for his spin at the hairpin during the Canadian Grand Prix.

The Finn was running third when he rotated on the out-lap following his sole pitstop, causing him to lose around 12 seconds and a place on the podium to Williams’s Valtteri Bottas.

“Obviously it is something different than has been happening all year, otherwise I wouldn’t have spun,” said Raikkonen. “It was nothing to do with the tyres; it was something to do with the pitstop, maps and stuff like that.

“It is something that we probably should have been smarter about and been able to avoid but it’s just on a map. I don’t know how to explain but it’s on the edge. You move the [throttle] pedal a little bit and you get a massive difference on the torque.

“There’s no way that I could have controlled it. It’s a stupid thing, but it happened so we have to learn from it.”

Vettel and Massa charge through field

Sebastian Vettel and Felipe Massa both recovered from problems in qualifying to record points finishes in the Canadian Grand Prix.

Vettel started his Ferrari 18th after suffering an ECU problem on Saturday that robbed his engine of power and meant he was 16th fastest, missing the Q1 cut.

He then received a five-place grid penalty for earlier overtaking Roberto Merhi’s Manor Marussia under red flags in final free practice.

Using a two-stop strategy, and surviving a couple of close moments while passing Fernando Alonso’s McLaren-Honda and Nico Hulkenberg’s Force India, Vettel finished fifth, just 4.278s behind team-mate Kimi Raikkonen. “We had a great car in the race and the pace just kept coming,” Vettel said. “As soon as we were in free air we could really progress.”

Massa charged to sixth, after starting 15th thanks to a turbo-wastegate problem on his Williams-Mercedes that ruined his qualifying session. “I was very happy with my race,” said Massa (below). “Very happy with the overtaking, the pace, the strategy.”



Maldonado takes first points of year

Pastor Maldonado scored his first points of the season with a seventh-place finish in the Canadian Grand Prix, the Venezuelan’s best result since he finished fifth in the 2012 Abu Dhabi GP for Williams.

The Lotus driver qualified sixth, but lost a place on the first lap of the race when Nico Hulkenberg’s Force India drove around the outside at Turn 3.

He repassed the Force India with an early pitstop, lost places to Sebastian Vettel’s Ferrari and Felipe Massa’s Williams, but took seventh spot when team-mate Romain Grosjean was forced to pit for a second time after colliding with backmarker Will Stevens.

Thus Maldonado finished a race for only the second time this season, recording the ninth points finish of his F1 career.

Lotus head of trackside operations Alan Permane said: “Pastor did a fantastic job. We asked a lot of him to run 53 laps on a set of tyres.”

Q&A

PASTOR MALDONADO
LOTUS DRIVER



How does it feel to finally get some points on the board?

It’s quite positive. We’ve been pushing very hard through the season to try to be there. For many reasons we weren’t. We did an amazing job to fix all the problems in the car; no mistakes during the weekend, quite clean. And we showed when everything is working together we are strong enough to fight for good points.

How was the race from your point of view?

It was a calm race – not much to do from my side, just looking after the tyres because we were forced to pit quite soon because of Hulkenberg. It was quite hard with the tyres for the last 20 laps, but we managed well, from the pitwall, the engine, the strategies – everything was working as expected.

Why do you think the Lotus-Mercedes package was so strong here?

We managed to put everything together this weekend. This track is quite fast and we have a low-drag car, and very good grip in these kinds of slow corners.

Why do you think the race pace wasn’t quite as strong as the qualifying speed?

At the beginning we were there; we’ve just been forced to pit so early while they [Williams and Ferrari] were on a different strategy, and that’s why you saw a big difference.

Was that your best race yet for Lotus, in terms of your own performance?

No, no way! For sure I have driven better!

STORIES OF THE RACE

“There was absolutely nowhere I could go unless I drive on the grass, which I don't think should be the rule”



Stevens calls for respect after Grosjean clash

Manor's Will Stevens has called for more respect from his F1 rivals when lapping cars, following his collision with Lotus driver Romain Grosjean.

After drawing alongside Stevens on the run down to the final chicane, Grosjean pulled back onto the racing line too early and clipped the Marussia's front wing.

Both were forced to pit, with Grosjean dropping from fifth to outside the top 10 and receiving a five-second time penalty for causing the collision.

"If cars want to try and cut across you in braking zones, those types of accidents are only going to happen more," said Stevens.

"I understand blue flags and that we need to let the guys past, but I feel like I am always really fair with that.

"In return I think it would be nice if they could respect us and give us at least a car width's room to take into the corner."

Grosjean, who recovered to finish 10th, took responsibility for the collision. "They probably could have made it more clear that they would let me by, but it's my fault that I came back too much on the left," said the Frenchman.

Sainz bemoans toughest race yet

Carlos Sainz Jr described the Canadian GP as "the toughest race of the season" for his Toro Rosso team.

After qualifying 11th, Sainz predicted that the layout of the Montreal circuit would make it difficult for the STR10 to do well, thanks to its Renault engine's power deficit and thirst for fuel.

After finishing a lapped 12th in the race, he said: "In Spain we have a saying that the one who tells you before doesn't betray you.

"We were lifting off 150 metres from the braking zones [to save fuel]. The brakes get cooled down, the tyres grain because the brakes are cooling down, and you don't put temperature into the front tyres. It's a snowball effect.

"I managed to overtake Daniel [Ricciardo] and got really close to [Sergio] Perez, but we were very far off the points today."



Ricciardo 'banging head against a wall'

Daniel Ricciardo was adamant he has not forgotten how to drive after finishing a lap down in the Canadian Grand Prix, scene of his first Formula 1 win in 2014.

The Australian qualified ninth for this year's race, leading him to declare Red Bull "lost" over how to make the RB11 quicker and compare the quality of his session with sweaty male genitals.

He fared poorly in the race too, finishing 13th and more than 33 seconds adrift of ninth-placed team-mate Daniil Kvyat. The result left Ricciardo convinced that something was wrong with his car.

"That was one of those races where I was going round and round, banging my head against a wall," Ricciardo told AUTOSPORT.

"I made a few jokes on Saturday, thinking Sunday would be better, and I didn't think in my wildest dreams it would end up how it did.

"For now I'm smiling because I'm sure something was fundamentally up with the car. I know I'm not a second slower than Daniil and I know I haven't forgotten how to drive."

Ricciardo is set to get a new chassis for the next race in Austria, but not as a result of his struggles in Canada.

DRAWING BOARD

by Craig Scarborough

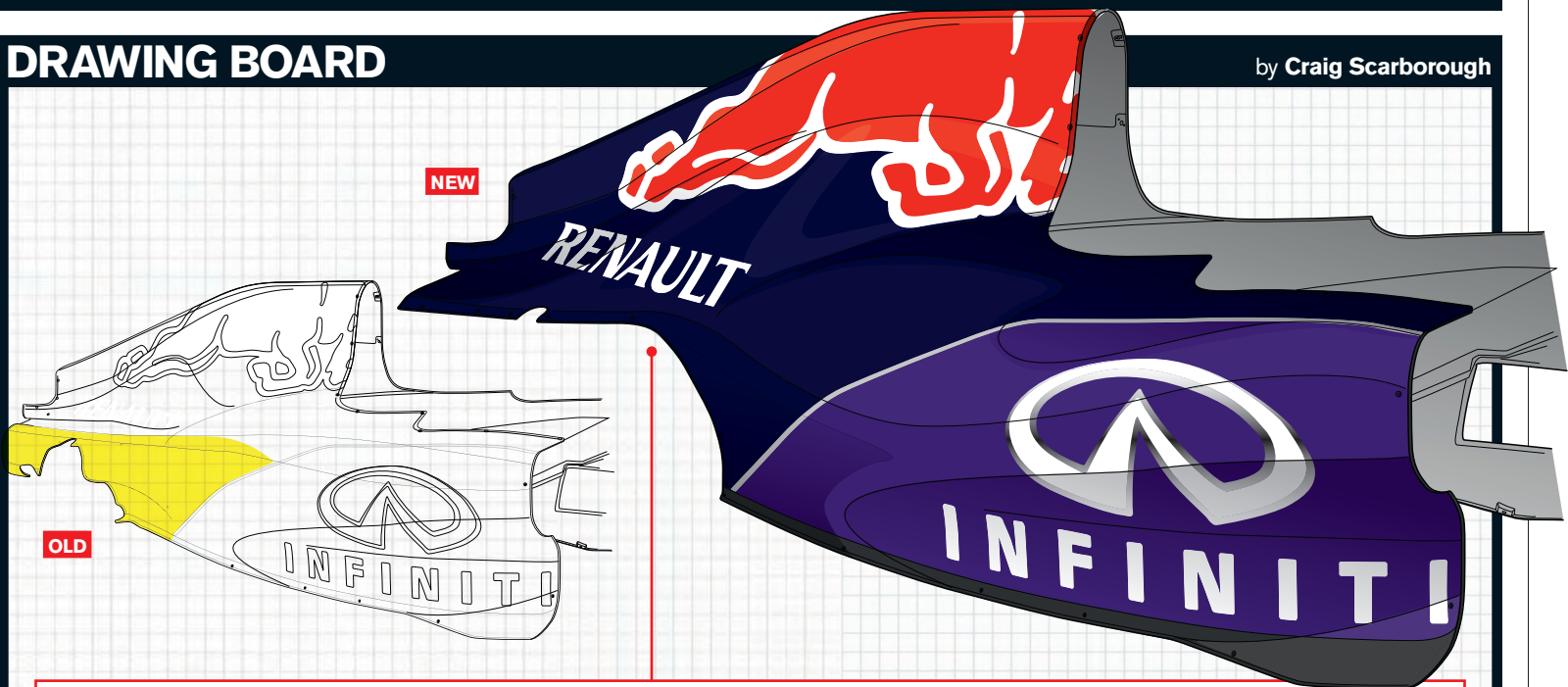

RED BULL TWEAKS SIDEPODS TO AID CAR COOLING

Without the benefit of using upgrade tokens to add power to the engine, Red Bull instead produced a big sidepod upgrade, along with new brake ducts and front turning vanes.

The new sidepod bodywork was also a change in how the team can tune the car. Uniquely, Red Bull produces the entire sidepod and engine cover as one part. If a different cooling level is required,

the panel is completely replaced. Having to transport these large bodywork sections must be a challenge, so now the sidepod has a removable cooling outlet panel, to allow different sections to be

run to tune the cooling. As well as this change, the sidepods are also a new shape, being even more narrow and sloped, for better airflow to the rear of the car.

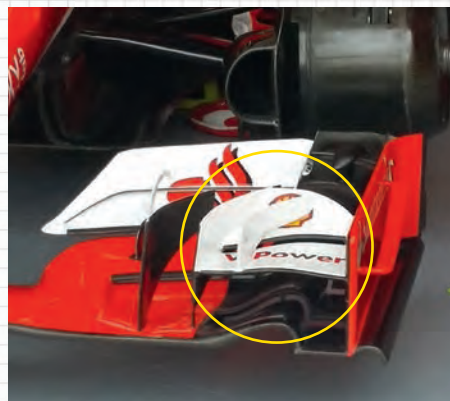

FERRARI MODIFIES FRONT-WING FINS

Ferrari brought a small revision to the front wing, with the fin on the upper winglet changed for a longer, more curved version.

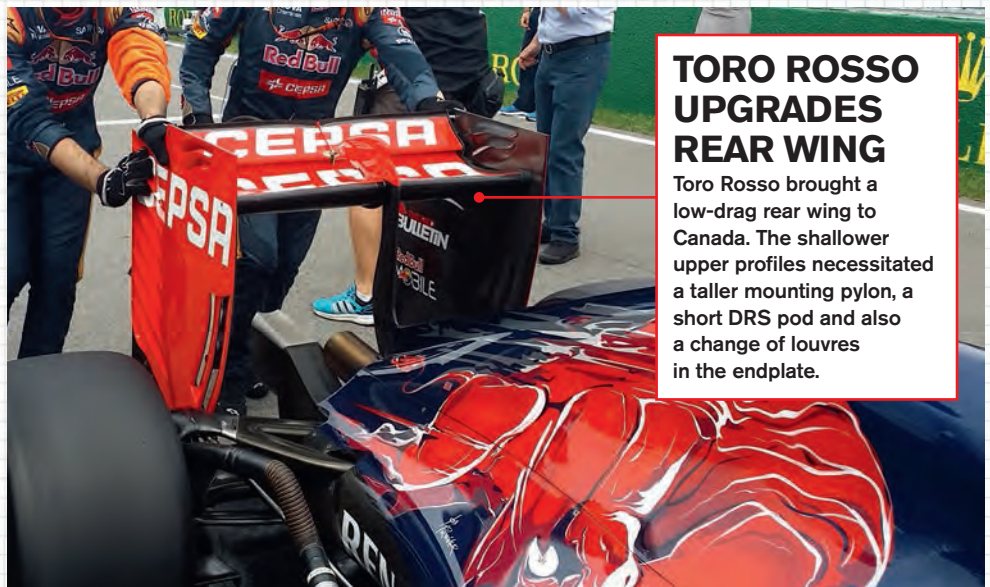

TORO ROSSO UPGRADES REAR WING

Toro Rosso brought a low-drag rear wing to Canada. The shallower upper profiles necessitated a taller mounting pylon, a short DRS pod and also a change of louvres in the endplate.

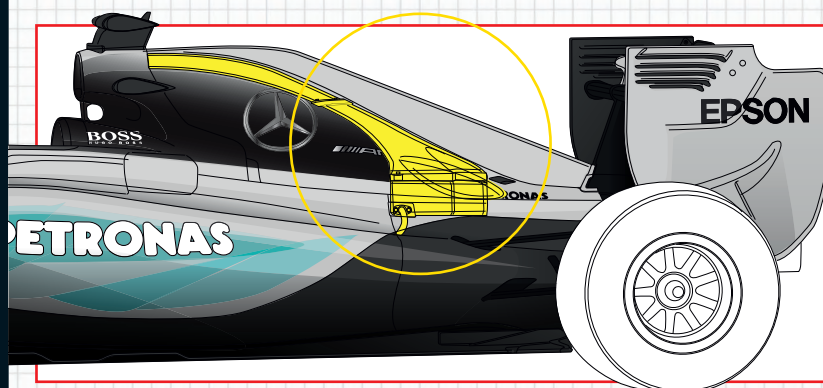

MERCEDES BOOSTS ERS

Having lost a one-two finish to ERS failure in last year's Canadian GP, and been marginal on braking this year, Mercedes had to monitor closely its systems in Montreal.

The heavy braking demands of the Circuit Gilles Villeneuve are good for energy recovery, but the electrical throughput

creates thermal problems for the ERS hardware.

To combat this, Mercedes increased the size of the ERS water radiator behind the engine. This small radiator is fed by a duct from the rollhoop and the increase in size forced the team to add blisters to clear the larger cooler.

DRIVER RATINGS

MERCEDES

**NICO ROSBERG**

Arrived in Montreal after two wins on the bounce, but was derailed by a "bad set" of tyres in qualifying, and wound up behind his team-mate. When Hamilton nailed the start, Rosberg was forced to maintain a watching brief, and needed more patience when his brakes started to overheat. He got within DRS range a couple of times later, but Hamilton always had enough in hand.

**LEWIS HAMILTON**

Began the weekend by telling the world the disaster of Monaco was behind him and then drove like it too. Hitting the wall in the wet in free practice was a blip, but messy driving in final practice potentially disastrous. Hamilton again pulled the rabbit from the hat at the crucial moment, taking the 44th pole of his F1 career. Victory after that was pretty much a formality.

RED BULL

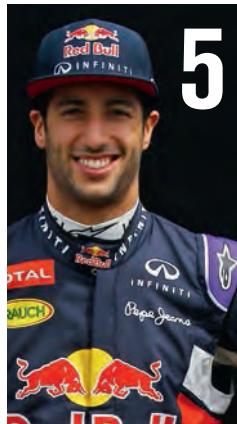
**DANIEL RICCIARDO**

Said the aim was to get through the grand prix without having to take a grid penalty for an engine change. Managed that, but last year's Canadian GP victor was furious with the RB11's lack of pace, declaring the team "lost" when trying to improve the car. Finished race more than 33s adrift of his team-mate. Suspects something is seriously awry with his chassis.

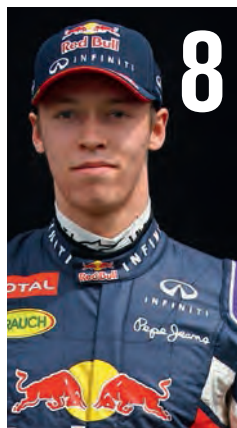
**DANIIL KVYAT**

Buoyed by his excellent result in Monaco, Kvyat was on good form again, clearly feeling the benefit of another reliable and incident-free run in free practice. Outqualified his team-mate for the second time this season and did as well as he could in the race, keeping ahead of Perez's Force India and repelling a late challenge from Grosjean's Lotus to grab two points.

WILLIAMS

**FELIPE MASSA**

His weekend started eventfully as he argued over driving standards with Max Verstappen, and got more eventful still when a faulty fixing in his Mercedes engine's turbo wastegate limited him to 17th fastest in qualifying. Penalties for Verstappen and Vettel boosted him a couple of places before the start, though, and he produced an excellent drive to finish sixth.

**VALTTERI BOTTAS**

Felt Williams should be back to its Ferrari-bothering best on this circuit and qualified within a tenth of fellow Finn Raikkonen to set up a rematch of their Spanish GP duel. Hung on as best he could in the race against a faster car, and gratefully accepted the gift of his first podium of the season when Raikkonen's new Ferrari engine went wild exiting the hairpin.

TORO ROSSO

**MAX VERSTAPPEN**

Took a lot of heat for not backing down over his Monaco collision with Grosjean, and fitting a fifth engine to his Toro Rosso after Friday practice meant his five-place grid penalty for that incident became a 15-place one. Took eight of those after qualifying 12th and the rest as a 10s penalty at his pitstop. Had the faster tyre for the final stint but got stuck behind Ericsson's Sauber.

**CARLOS SAINZ JR.**

Car was not competitive here, struggling with the Renault's power deficit and need to run minimal downforce to compensate. Did well to qualify 11th, but would have just bumped Ricciardo out of the top 10 in Q2 had he strung all his sectors together. Expected "the toughest race of the season" and got it. Drove decently, but points were never on the cards.

LOTUS

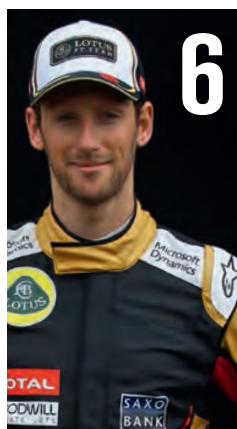
**ROMAIN GROSJEAN**

Grosjean looked quick in practice and felt a pitlane mix-up with his team-mate ahead of Q3 run cost him a shot at third on the grid, but fourth was the best possible. Race pace was weaker, but seventh went begging to misjudged move on Will Stevens that earned Grosjean a time penalty and extra pitstop. Team felt he should have repassed Kvyat before the flag.

**PASTOR MALDONADO**

Has a terrible finishing record in 2015 so far, but starting sixth (his highest grid position since 2012) offered hope of reversing that trend. For once, he stayed out of trouble to record his best finish since... 2012! Made an early stop to repass Hulkenberg and impressed the team with a 53-lap marathon on the soft tyre. Seventh was a just reward for recent good driving.

MANOR

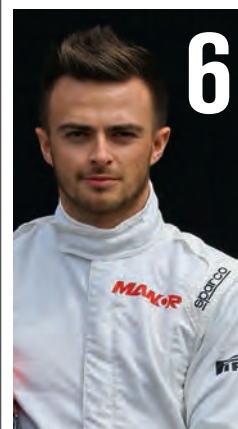
**WILL STEVENS**

Following a first defeat of the season to his team-mate in Monaco, Stevens hoped to be back on top at this race. Felt less comfortable with the car here than at previous events and was shaded fractionally by Merhi in qualifying (by just 0.024s). Got ahead in the race early on, but suffered a slow pitstop and trailed Merhi by 3s when Grosjean spoiled the fun.

**ROBERTO MERHI**

Signs he is finally getting to grips with the MR-04. Felt an engine change (on both cars) eliminated a straightline speed deficit, and persisting with a theoretically worse front wing configuration is working for him. Edged Stevens on Saturday, and, having started ahead for the first time this year, was on course to finish ahead when his car broke a driveshaft.

BEN ANDERSON reviews and rates each driver's grand prix weekend performance out of 10

FERRARI



SEBASTIAN VETTEL Hoped Ferrari's upgraded engine would allow him to put more pressure on the Mercedes, but was derailed by a grid penalty for passing Merhi under red flags in FP3 and an ECU problem in qualifying, so he exited in Q1. From 18th on the grid he charged into the top five after surviving some close moments with other cars at the final chicane. If only he'd started further up...



KIMI RAIKKONEN Suggested he had done the qualifying homework set for him by team boss Maurizio Arrivabene by being best of the rest on Saturday, but Vettel's problems mean the jury is still out. Wasn't quick enough to challenge Mercedes in the race, but would have finished on the podium certainly but for a bizarre spin caused by a sudden burst of torque from his engine.

McLAREN



FERNANDO ALONSO Expected a difficult weekend on a circuit that demands pure power. Had to change his engine after FP2, forcing him to miss most of FP3. Split the Saubers in qualifying and gained a place before the start thanks to Verstappen's grid penalty. Felt excessive fuel saving requirements made him look "like an amateur driver" in the race. Exhaust problem put him out of his misery.



JENSON BUTTON Honda brought an updated engine to Canada but the ERS on Button's failed during FP3 and forced him to miss qualifying for the second time in the past four races. When damage was found to the turbo and MGU-H he copped a drivethrough penalty before the race had even started. Took that on lap one and then droned around until his exhaust failed too.

FORCE INDIA

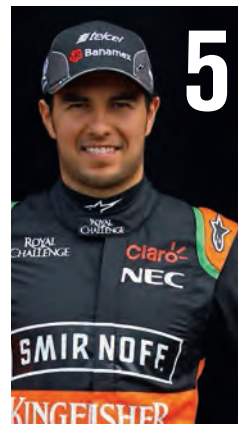

SERGIO PEREZ Followed up an excellent drive in Monaco with a weaker performance here, and was shaded by his team-mate. Felt wrong tyre pressures exaggerated the 0.724s gap to Hulkenberg in qualifying, but he didn't fare better in the race. Spent most of it stuck behind Kvyat as he struggled with understeer, then fell away in the closing stages as fuel and tyre management took over.



NICO HULKENBERG Felt the lap he "pulled out of his arm-sleeve" was his best of the year to beat both Red Bulls in qualifying, though he could have been quicker had he strung everything together. Jumped Maldonado with an aggressive first-lap move in the race, but fell behind after going long on his first stint. Spin at the chicane under attack from Vettel was unnecessary.

SAUBER



MARCUS ERICSSON Has been totally shaded by his rookie team-mate recently but was much stronger here. Should arguably have split the Toro Rossos in Q2, though Verstappen's penalty made this redundant. Felt points would be on in the race but they weren't. Was too slow around his pitstop to stay ahead of Sainz but at least kept one Toro Rosso behind.



FELIPE NASR Has been driving very well recently but blotted his copy book in final practice, after accidentally opening his DRS while weaving to warm up his tyres. Sauber did a great job to repair the car, but Nasr didn't string it together in Q2 so wound up 0.358s adrift of his team-mate. Was slow in the race too, hampered by a lack of power and overheating brakes. A race to forget.



RESULTS

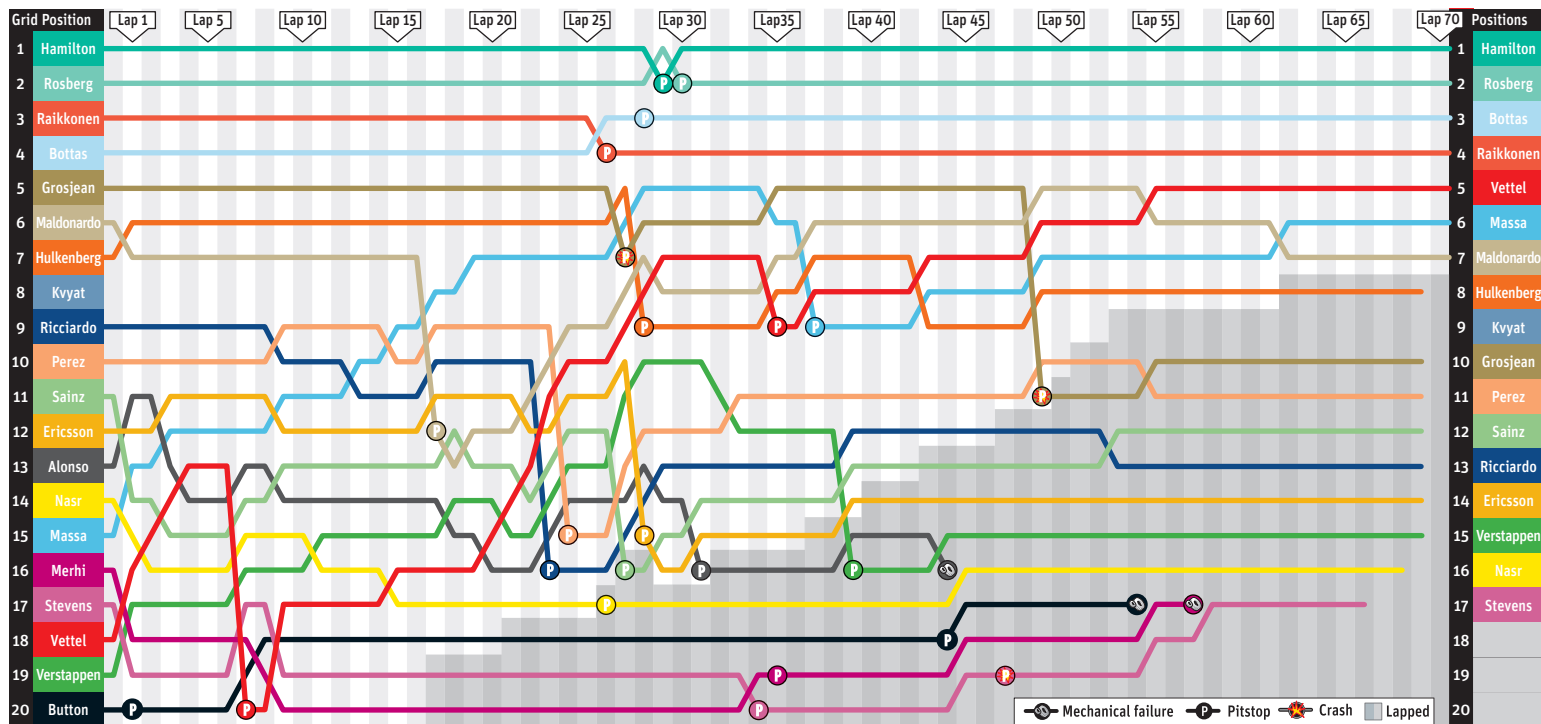

PRACTICE 1: Friday

POS	DRIVER	TIME
1	HAMILTON	1m16.212s
2	ROSBERG	1m16.627s
3	GROSJEAN	1m17.721s
4	HULKENBERG	1m17.871s
5	VETTEL	1m17.905s
6	MASSA	1m17.985s
7	KVYAT	1m18.021s
8	MALDONADO	1m18.026s
9	ALONSO	1m18.128s
10	VERSTAPPEN	1m18.257s
11	BOTTAS	1m18.325s
12	RAIKKONEN	1m18.439s
13	PEREZ	1m18.503s
14	RICCIARDO	1m18.775s
15	BUTTON	1m18.786s
16	NASR	1m18.948s
17	SAINZ	1m19.065s
18	ERICSSON	1m19.165s
19	MERHI	1m20.616s
20	STEVENS	1m20.624s

PRACTICE 2: Friday

POS	DRIVER	TIME
1	HAMILTON	1m15.988s
2	VETTEL	1m16.304s
3	RAIKKONEN	1m16.310s
4	ROSBERG	1m16.440s
5	MALDONADO	1m16.600s
6	BOTTAS	1m16.849s
7	GROSJEAN	1m16.864s
8	MASSA	1m17.041s
9	KVYAT	1m17.092s
10	RICCIARDO	1m17.111s
11	HULKENBERG	1m17.120s
12	ERICSSON	1m17.261s
13	SAINZ	1m17.318s
14	PEREZ	1m17.367s
15	ALONSO	1m17.627s
16	VERSTAPPEN	1m17.657s
17	NASR	1m17.751s
18	BUTTON	1m18.135s
19	MERHI	1m19.531s
20	STEVENS	1m19.734s

PRACTICE 3: Saturday

POS	DRIVER	TIME
1	ROSBERG	1m15.660s
2	RAIKKONEN	1m16.233s
3	GROSJEAN	1m16.772s
4	BOTTAS	1m16.914s
5	PEREZ	1m16.993s
6	KVYAT	1m17.021s
7	MASSA	1m17.122s
8	VETTEL	1m17.197s
9	SAINZ	1m17.396s
10	MALDONADO	1m17.573s
11	ERICSSON	1m17.578s
12	HULKENBERG	1m17.876s
13	RICCIARDO	1m17.892s
14	NASR	1m18.446s
15	BUTTON	1m18.473s
16	VERSTAPPEN	1m18.492s
17	STEVENS	1m19.822s
18	ALONSO	1m19.874s
19	MERHI	1m20.231s
20	HAMILTON	1m21.492s

Weather: 19C, sunny

Weather: 21C, overcast/wet

Weather: 13C, sunny



QUALIFYING TIMES

POS	DRIVER	QUALIFYING 1	QUALIFYING 2	QUALIFYING 3
1	HAMILTON	1m15.895s (3)	1m14.661s (1)	1m14.393s
2	ROSBERG	1m15.893s (2)	1m14.673s (2)	1m14.702s
3	RAIKKONEN	1m16.259s (6)	1m15.348s (4)	1m15.014s
4	BOTTAS	1m16.552s (10)	1m15.506s (5)	1m15.102s
5	GROSJEAN	1m15.833s (1)	1m15.187s (3)	1m15.194s
6	MALDONADO	1m16.098s (4)	1m15.622s (6)	1m15.329s
7	HULKENBERG	1m16.186s (5)	1m15.706s (7)	1m15.614s
8	KVYAT	1m16.415s (9)	1m15.891s (8)	1m16.079s
9	RICCIARDO	1m16.410s (8)	1m16.006s (10)	1m16.114s
10	PEREZ	1m16.827s (13)	1m15.974s (9)	1m16.338s
11	SAINZ	1m16.611s (11)	1m16.042s	-
12	VERSTAPPEN	1m16.361s (7)	1m16.245s	-
13	ERICSSON	1m16.796s (12)	1m16.262s	-
14	ALONSO	1m17.012s (15)	1m16.276s	-
15	NASR	1m16.968s (14)	1m16.620s	-
16	VETTEL	1m17.344s	-	-
17	MASSA	1m17.886s	-	-
18	MERHI	1m19.133s	-	-
19	STEVENS	1m19.157s	-	-
20	BUTTON	-	-	-

Weather: 17C, sunny

QUALIFYING STATISTICS

	HEAD TO HEAD	
ROSBERG	1	6
RICCIARDO	5	2
MASSA	4	3
VETTEL	6	1
ALONSO/MAGNUSSEN	2	4
PEREZ	2	5
SAINZ	5	2
GROSJEAN	6	1
ERICSSON	2	5
STEVENS	4	1



POLE POSITION TROPHY

HAMILTON
AUS MAL PRC BRN MC CDN 6

ROSBERG
E 1



RACE: 70 LAPS - 189.686 MILES

POS	DRIVER	DRIVER NUMBER	TEAM	LAPS	TOTAL TIME	FASTEST LAP	PITSTOPS	TIME IN PITS	GRID
1	LEWIS HAMILTON	44	MERCEDES	70	1h31m53.145s	1m17.472s	1	23.708s	1
2	NICO ROSBERG	6	MERCEDES	70	+2.285s	1m17.637s	1	23.321s	2
3	VALTTERI BOTTAS	77	WILLIAMS-MERCEDES	70	+40.666s	1m17.922s	1	25.541s	4
4	KIMI RAIKKONEN	7	FERRARI	70	+45.625s	1m16.987s	2	48.208s	3
5	SEBASTIAN VETTEL	5	FERRARI	70	+49.903s	1m17.105s	2	51.186s	18
6	FELIPE MASSA	19	WILLIAMS-MERCEDES	70	+56.381s	1m17.553s	1	23.912s	15
7	PASTOR MALDONADO	13	LOTUS-MERCEDES	70	+1m06.664s	1m18.385s	1	23.660s	6
8	NICO HULKENBERG	27	FORCE INDIA-MERCEDES	69	-1 lap	1m18.238s	1	23.507s	7
9	DANIIL KVIYAT	26	RED BULL-RENAULT	69	-1 lap	1m18.048s	1	23.681s	8
10	ROMAIN GROSJEAN	8	LOTUS-MERCEDES	69	-1 lap	1m17.969s	2	unavailable	5
11	SERGIO PEREZ	11	FORCE INDIA-MERCEDES	69	-1 lap	1m18.889s	1	23.453s	10
12	CARLOS SAINZ JR	55	TORO ROSSO-RENAULT	69	-1 lap	1m18.811s	1	24.277s	11
13	DANIEL RICCIARDO	3	RED BULL-RENAULT	69	-1 lap	1m19.060s	1	23.997s	9
14	MARCUS ERICSSON	9	SAUBER-FERRARI	69	-1 lap	1m18.890s	1	24.149s	12
15	MAX VERSTAPPEN	33	TORO ROSSO-RENAULT	69	-1 lap	1m18.616s	1	36.105s	19
16	FELIPE NASR	12	SAUBER-FERRARI	68	-2 laps	1m19.088s	1	24.795s	14
17	WILL STEVENS	28	MARUSSIA-FERRARI	66	-4 laps	1m20.707s	2	unavailable	17
R	ROBERTO MERHI	98	MARUSSIA-FERRARI	57	half-shaft	1m20.804s	1	26.986s	16
R	JENSON BUTTON	22	McLAREN-HONDA	54	exhaust	1m18.856s	2	43.431s	20
R	FERNANDO ALONSO	14	McLAREN-HONDA	44	exhaust	1m19.580s	1	23.553s	13

Weather: 20C, cloudy. Winner's average speed: 123.862mph. Fastest lap: Raikkonen 1m16.987s (126.713mph) on lap 42. Lap leader: 1-28 Hamilton, 29 Rosberg, 30-70 Hamilton.

TYRE CHOICE

STINT 1	STINT 2	STINT 3
Supersoft U	Soft N	
Supersoft U	Soft N	
Supersoft U	Soft N	
Supersoft U	Soft N	Supersoft U
Supersoft N	Soft N	Soft U
Soft N	Supersoft N	
Supersoft U	Soft N	
Supersoft U	Soft N	
Supersoft U	Soft N	Soft N
Supersoft U	Soft N	
Supersoft U	Soft N	
Supersoft U	Soft N	
Soft N	Supersoft N	
Supersoft N	Soft N	
Soft N	Supersoft N	Supersoft N
Soft N	Supersoft N	
Supersoft N	Soft N	

N - new; U - used

DRIVERS' STANDINGS

POS	DRIVER	PTS	AUS	MAL	PRC	BRN	E	MC	CDN	A	GB	H	B	I	SGP	J	RUS	USA	MEX	BR	UAE
1	HAMILTON	151	1st	2nd	1st	1st	2nd	3rd	1st	-	-	-	-	-	-	-	-	-	-	-	-
2	ROSBERG	134	2nd	3rd	2nd	3rd	1st	1st	2nd	-	-	-	-	-	-	-	-	-	-	-	-
3	VETTEL	108	3rd	1st	3rd	5th	3rd	2nd	5th	-	-	-	-	-	-	-	-	-	-	-	-
4	RAIKKONEN	72	ret	4th	4th	2nd	5th	6th	4th	-	-	-	-	-	-	-	-	-	-	-	-
5	BOTTAS	57	DNS	5th	6th	4th	4th	14th	3rd	-	-	-	-	-	-	-	-	-	-	-	-
6	MASSA	47	4th	6th	5th	10th	6th	15th	6th	-	-	-	-	-	-	-	-	-	-	-	-
7	RICCIARDO	35	6th	10th	9th	6th	7th	5th	13th	-	-	-	-	-	-	-	-	-	-	-	-
8	KVIYAT	19	DNS	9th	ret	9th	10th	4th	9th	-	-	-	-	-	-	-	-	-	-	-	-
9	GROSJEAN	17	ret	11th	7th	7th	8th	12th	10th	-	-	-	-	-	-	-	-	-	-	-	-
10	NASR	16	5th	12th	8th	12th	12th	9th	16th	-	-	-	-	-	-	-	-	-	-	-	-
11	PEREZ	11	10th	13th	11th	8th	13th	7th	11th	-	-	-	-	-	-	-	-	-	-	-	-
12	HULKENBERG	10	7th	14th	ret	13th	15th	11th	8th	-	-	-	-	-	-	-	-	-	-	-	-
13	SAINZ	9	9th	8th	13th	ret	9th	10th	12th	-	-	-	-	-	-	-	-	-	-	-	-
14	VERSTAPPEN	6	ret	7th	17th	ret	11th	ret	15th	-	-	-	-	-	-	-	-	-	-	-	-
15	MALDONADO	6	ret	ret	ret	15th	ret	ret	7th	-	-	-	-	-	-	-	-	-	-	-	-
16	ERICSSON	5	8th	ret	10th	14th	14th	13th	14th	-	-	-	-	-	-	-	-	-	-	-	-
17	BUTTON	4	11th	ret	14th	DNS	16th	8th	ret	-	-	-	-	-	-	-	-	-	-	-	-
18	ALONSO	0	-	ret	12th	11th	ret	ret	ret	-	-	-	-	-	-	-	-	-	-	-	-
19	MERHI	0	DNQ	15th	16th	17th	18th	16th	ret	-	-	-	-	-	-	-	-	-	-	-	-
20	STEVENS	0	DNQ	DNS	15th	16th	17th	17th	17th	-	-	-	-	-	-	-	-	-	-	-	-
21	MAGNUSSEN	0	DNS	-	-	-	-	-	-	-	-	-	-	-	-	-	-	-	-	-	-

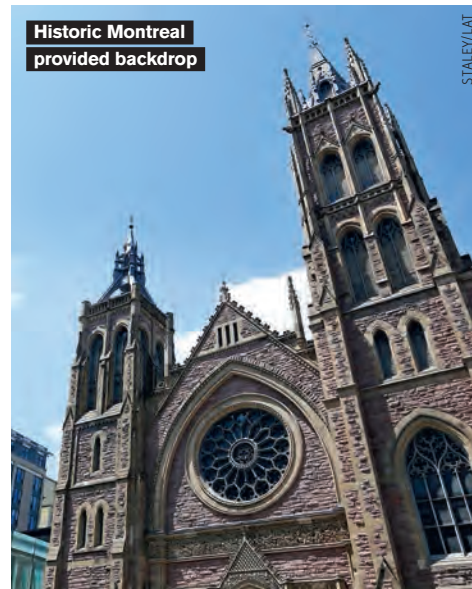
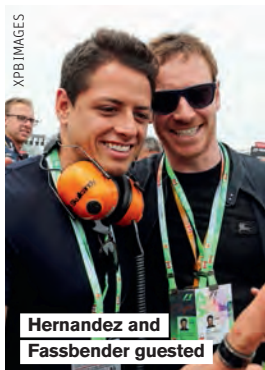

SPEED TRAP FOR EACH CONSTRUCTOR (QUALIFYING)

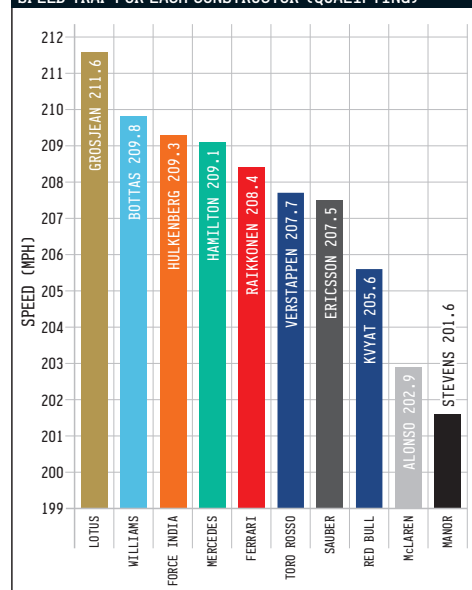

CONSTRUCTORS' STANDINGS

POS	CONSTRUCTOR	PTS	AUS	MAL	PRC	BRN	E	MC	CDN	A	GB	H	B	I	SGP	J	RUS	USA	MEX	BR	UAE
1	MERCEDES	285	43	33	43	40	43	40	43	-	-	-	-	-	-	-	-	-	-	-	-
2	FERRARI	180	15	37	27	28	25	26	22	-	-	-	-	-	-	-	-	-	-	-	-
3	WILLIAMS	104	12	18	18	13	20	0	23	-	-	-	-	-	-	-	-	-	-	-	-
4	RED BULL	54	8	3	2	10	7	22	2	-	-	-	-	-	-	-	-	-	-	-	-
5	LOTUS	23	0	0	6	6	4	0	7	-	-	-	-	-	-	-	-	-	-	-	-
6	SAUBER	21	14	0	5	0	0	2	0	-	-	-	-	-	-	-	-	-	-	-	-
7	FORCE INDIA	21	7	0	0	4	0	6	4	-	-	-	-	-	-	-	-	-	-	-	-
8	TORO ROSSO	15	2	10	0	0	2	1	0	-	-	-	-	-	-	-	-	-	-	-	-
9	McLAREN	4	0	0	0	0	0	4	0	-	-	-	-	-	-	-	-	-	-	-	-
10	MARUSSIA	0	0	0	0	0	0	0	0	-	-	-	-	-	-	-	-	-	-	-	-

FOR IN-DEPTH RESULTS
forix.autosport.com

Formula E

Moscow (RUS)

June 6

Round 9/10

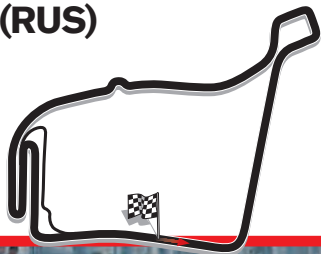

Piquet jumped Vergne at start of the race



Piquet has a Red-Square-letter day

WHEN YOU START THE DAY WITH A TWO-POINT championship lead and head home with 17 up your sleeve, as well as a shiny new trophy, chances are you've had a pretty good day. That was Nelson Piquet Jr in Moscow.

The season's penultimate event, held beneath Red Square, decided who would fight it out for the championship during London's double-header finale at the end of this month. Piquet led the way heading to Moscow, with Sebastien Buemi his closest challenger, Lucas di Grassi a little further back and Nicolas Prost, Jerome d'Ambrosio and Sam Bird also in the mix. By the end of tough days, Prost (an e.dams pit blunder), d'Ambrosio (problematic pitstop) and Bird (a medley of misfortune, see right) had effectively exited the scene, while Piquet was firmly in the box seat. That outcome is partly due to his own impressive performance, but also the result of a disastrous afternoon for Buemi.

Piquet's day went to plan. From second on the grid, just 0.020 seconds away from Jean-Eric Vergne in qualifying, he got the best of the start and assumed the lead. Figuring attack was the best form of defence, he used the clear air and set about building a lead that was almost six seconds at two-thirds distance. The job was almost done and, even though Piquet had less juice to use on

the run home than his rivals, there was enough to win by two seconds.

"We knew it was going to be an important race for us, after what I would say was not a very strong performance in Berlin," Piquet said of the previous round, where he finished fourth.

"If I didn't qualify at the front, it would have been close to impossible to win the race – track position here was very important. I had a great start – our procedure is still a mixture of a little bit of luck and good reaction, and the set-up. Everything worked perfectly.

"I probably tried to use [energy] at the beginning to get a gap, so at the end [di Grassi] ended up catching up but we still had a little bit more if we had to push."

But for an overheating battery, di Grassi could indeed have made Piquet's life interesting. Still smarting from losing his Berlin victory after being disqualified, di Grassi jumped Vergne during the pitstops and had closed to within 1.5s of the lead with three laps to go. He had an energy advantage, and both drivers had Fanboost at their disposal, but di Grassi cruised home rather than chase because of concerns about making the flag.

Buemi joined them on the podium, but would lose the most out of the three in the championship context. With energy to spare, he was well placed



Buemi (right) did not keep his trophy

for a charge in the second half of the race, but a major oversight led to e.dams working to a minimum pitstop time of 68s, rather than the mandatory 58. It hurt on the track and, while he regrouped to snatch third from Vergne on the final lap, there was worse to come. The extra seconds waiting for '68' led to Buemi being unsafely released into the path of Nick Heidfeld. Stewards added 29 seconds to his time, the equivalent of a drive-through, and he dropped to ninth.

What does it all mean in the fight to become the maiden Formula E champion? Piquet leads di Grassi by 17 points, and could feasibly wrap up the title in the Saturday race in London, while Buemi is 23 behind, thanks to losing 13 points in his drop from third to ninth. With 60 points available at Battersea, Prost remains mathematically in with a shout, but is 36 points behind.

Buemi's penalty and fight with Vergne elevated Heidfeld to his maiden Formula E podium. Both Buemi and Vergne slowed exiting the back chicane, Buemi appearing to want to let Vergne back past after cutting the chicane, and Heidfeld pounced to pass the polesitter.

Daniel Abt was fifth, from Salvador Duran, a frustrated Antonio Felix da Costa (see right), Prost and Buemi, while Justin Wilson picked up the final point with 10th on his debut.



Di Grassi followed Vergne until the stops

S BLOKHAW/LAT

FOR FULL RESULTS, PAGE 44

IN THE PADDOCK

MITCHELL ADAM
INTERNATIONAL
EDITOR

@DrMitchellAdam



IF YOU'VE EVER BEEN TO MOSCOW, you'll already know that many of the city's roads are about as smooth as your average WRC stage.

So I was particularly interested to see how race cars – and in particular these especially heavy single-seaters – would handle the bumpy streets. It didn't take long to find out, hearing the telltale sounds of carbonfibre scuffing on warped, elevated pieces of asphalt and surface changes, or simply smashing over the top of a manhole cover from the very start of practice.

OK, these things aren't new for a street circuit, but it's by far the most extreme case I've encountered at any venue. Drivers agreed, with one adding that you



couldn't use the normal racing line in some parts of the circuit.

Overall, though, drivers gave the layout a big tick. As did Dario Franchitti, a man who's raced on countless IndyCar and CART street courses, after his brief run for TV. Other than perhaps the need for another overtaking opportunity, which was particularly evident in the race, it had a bit of everything. And, impressively, given that the front straight was in use as a normal

road until Saturday morning, it was also ostensibly trouble-free from the outset.

The location gets an even bigger tick. A whole world away from Moscow Raceway rather than the actual 60 miles (let alone Sochi), it could not have been any closer to 'the people', in the city centre. And the flow of tourists through Red Square was towards the back, to St Basil's Cathedral. The next thing they saw was a race meeting, albeit with a very

Russian level of police standing out the front rather than welcoming information about how to buy tickets.

Street-circuit locations are generally like this, but in terms of putting Formula E in the spotlight, this took the cake. It'd be like having a race next to Buckingham Palace. The crowd didn't seem massive, but, in an untapped market without a massive motorsport culture, you have to start somewhere. So why not the city?

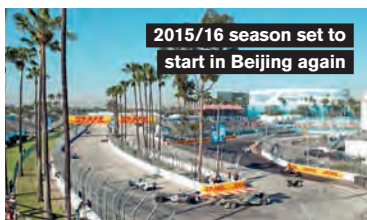

China to start 2015-16 season

FORMULA E'S SECOND SEASON will start in Beijing, but a month later in the year than the city's 2014-15 opener.

The Chinese capital hosted the series' inaugural race last September, but it was followed by a 10-week gap, owing to the cancellation of the race in Brazil and then the Malaysian event being postponed by five weeks.

A fairly familiar calendar will begin on October 17. AUTOSPORT understands that the races in Uruguay and Long Beach are unlikely to feature, while the Paris and Mexico City rounds are in, pending final sign-off. The Parisian race is set to start the European leg, in April.

BIG NUMBER

4th

Nelson Piquet Jr's worst result since failing to finish the second round of the series in Malaysia last November.

Franchitti laps around Moscow



DARIO FRANCHITTI ENJOYED some rare seat-time in Moscow, sampling Formula E machinery for the first time.

Franchitti, who was forced into retirement in late 2013, turned several laps for a TV piece.

"I think all I've really driven in anger since I had my crash was a DTM car at Goodwood last year, which was blinding good fun," the three-time Indy 500 winner told AUTOSPORT.

"But to get in the Formula E car, after commenting about them for so long, was cracking fun to do. I had to make sure I took it easy, because my instinct was to start getting after it!"

Trulli handed grid penalty

MOST OF THE RACE ACTION involved a flu-afflicted Jarno Trulli's defensive efforts against a faster Antonio Felix da Costa.

Eventually, da Costa got alongside on the inside of the back chicane, only for Trulli to skip the chicane and reclaim his position. A repeat occurred several laps later, and, when da Costa finally got past at Turn 3, Justin Wilson experienced the same. Trulli finished 18th without his rear wing, following contact with Loic Duval, and was handed a five-place London grid penalty.

"I don't know what he was doing. He was being a bit idiotic because he's a guy I've looked up to since I was a kid, and have a lot of



respect for," da Costa, who finished seventh, told AUTOSPORT.

"One thing is blocking – blocking is racing, fair enough – but it's another thing if someone else is inside and the corner is theirs, and you just cut the chicane to keep the position. He did it once, he did it twice and I had to overtake him three times. It ruined my race, I spent 15 or 20 laps behind him, spending way more energy, when maybe a top-five was possible."

BAD LUCK FOR BIRD

"That's probably the worst race day or weekend I can remember," Sam Bird surmised. Bird lost a wheel in first practice and had a throttle-sensor failure in the next. From 12th on the grid, he had to swap cars early after nicking a wall resulted in right-rear suspension damage. Bird retired when his second car's battery ran out. "These cars unfortunately, they break far too easily," he said. "That destroyed our race. We didn't really have very much luck on our side today."

CLOSE CONTENDERS

The top five in the championship heading to Moscow kept close company during qualifying. Championship leader Nelson Piquet Jr qualified second, ahead of his points rivals Lucas di Grassi (third in the standings), Sebastien Buemi (second), Jerome d'Ambrosio (fifth) and Nicolas Prost (fourth).

DUVAL'S DIFFICULTIES

After taking his first podium at Berlin Tempelhof two weeks earlier, Loic Duval had an eventful day. He crashed at the back chicane in the final minute of first practice, found the wall again at Turn 1 in the second, and stopped on track in qualifying. He raced from 19th to 11th, but was demoted to 15th for late contact with Jarno Trulli.



Dixon dominates after high-downforce dilemma

Scott Dixon didn't agree with his Ganassi team's set-up choice heading into the race, but, as **MARK GLENDENNING** explains, the New Zealander was quickly won over



34

IndyCar Texas (USA)



June 6

Round 8/15



Dixon drilled home his advantage

THE COMMAND TO START ENGINES WAS STILL 15 or so minutes away, but the first few rows of the dummy grid were already busy at Texas Motor Speedway last Saturday night.

Penske drivers and crew chiefs wandered down the rows casting glances at the relatively high-downforce package on the lead Ganassi cars. Their Ganassi counterparts were equally focused on the trimmed-out approach taken by their rivals.

"At the beginning of the race, I'm looking at Helio [Castroneves]'s set-up downforce-wise, and they're looking at mine," said Tony Kanaan. "We're like, 'somebody's going to get it right.'"

In this case, getting it right was a question of finding that aero sweet spot that would play to the demands of racing on a 1.5-mile superspeedway through sunset, while also preserving the tyres enough to get the cars somewhere close to their estimated 50-lap fuel range. And as subsequent events proved, the difference between getting it right and getting it wrong was immense. Scott Dixon won by almost eight seconds, with just three other cars still on the lead lap at the end. Polesitter Will Power finished three laps down.

Dixon's choice of aero package was a big part of the story, but still only a part. Indeed, he later admitted the aero set-up that contributed to an evening of absolute dominance wasn't even his first choice.

"The debate started [Friday night] after the warm-up," he said. "I thought I had my way. Then at about one o'clock this afternoon I got a text message from [engineer] Chris Simmons saying we were going the other way. I went and saw him and tried to push to go back.

"Thirty minutes before the race, I was still

moaning pretty good. Obviously, it's hard when you see the first four cars with a lot less downforce. The debate went back and forth. We were thinking about splitting the cars as far as [downforce] levels, but in hindsight, I'm glad they understood what they were doing. That's why they do what they do. I just drive the car."

Another major contributor to Dixon's success was the degree to which he and the team were able to continually tune the car at each stop to keep themselves in step with the way the track was changing as the sun went down. The #9 car actually wasn't handling all that well early in the race, and Dixon spent the first stint wrestling with armfuls of understeer.

"Once we got the balance right — got some front wing in the car, some tyre-pressure changes — the car was basically on rails," Dixon said.

He was quick in traffic, too, which had been his undoing at the same venue 12 months ago. And when all of those elements were combined, the results were devastating.

Dixon took the lead from Kanaan during the third round of stops, and the two Ganassi cars spent the next stint working to break away from a pursuing pack led mostly by Helio Castroneves. The Brazilian had gone for a less extreme downforce configuration than most of his team-mates, and the middle phase of the race featured outstanding combat between the leaders.

"We had good battles out there, really intense, really tough," said Castroneves. "Any day, any time, running with guys like that, who respect each other, it's fun, it's great. That's what I race for.

"I feel more safe being an inch beside each other [with Kanaan] than when I was running 12th

Dixon and Ganassi kept the car on song all night – even at the pitstops



Once we got the balance right – got some front wing – it was basically on rails

SCOTT DIXON

at Indianapolis towards the end with some people who have no respect for what they're doing.

"That, for me, was a fun race. I can go any time and race like that. Hopefully those young guys learn from it."

Even the best-executed race plan can benefit from a sprinkling of fairy dust, and for all of Dixon's and Ganassi's brilliance on Saturday night, they could easily have been undone by a yellow during the final stint. Indeed, four drivers – Marco Andretti, Carlos Munoz, James Jakes and Simon Pagenaud (who had started on the front row and marched progressively backwards as he struggled with his handling) – had elected to go off-sequence in the latter stages of the race in anticipation of precisely that.

And as gambles go, it wasn't a bad shout. Superspeedways and massive tyre drop-off combine to make prime breeding conditions for cautions, and at Texas, a few laps behind the safety car to allow for someone's shrapnel to be swept up after a brush with the wall is all but a formality. Had it happened during the final 50



The Penskes led from the start but would fade

laps on Saturday, Dixon might have been a sitting duck. But this was an evening in which fortune favoured the conventional. Not only was there no caution during the final stint, there was just one caution for the entire race – and even that was just a brief interruption for debris.

So although Andretti and Munoz, in particular, managed to gain a temporary advantage, the relentlessness of the green-flag laps exacted an increasingly stiff toll upon their tyres. With 10 laps to go, they'd fallen a full 10mph off the pace, and plunged out of the frame.

Elsewhere, championship leader Juan Pablo Montoya was confident that he could have been a contender were it not for a couple of misfortunes. One was a slow pitstop caused by a delayed tyre change. He lost a few seconds, but over the balance of the race, that was just about surmountable. Less easy to overcome was the miscommunication that resulted in his wing being adjusted incorrectly; a mistake that caused him to lose several positions in the space of a few laps.

"We came out of the pits there leading and we made a mistake with the front wing" he said.

"I asked to take wing out and [the team] went the wrong way. I started leading when I was on full stiff bars and full on the weight jacker, and it was still really pointy. I said, 'this is going to get really loose,' so I just backed off and let a few people by and it just started wearing the right rear tyre.

"By the time I stopped [again], I lost half a lap. You saw how good I was at the end, how I caught Helio. If that had been the case [all evening], we probably would've won, but it is what it is."

His mood was no doubt helped by the fact that he'd been able to further pad his points advantage over team-mate and closest championship rival Will Power, who had spent the entire evening trying to recover from going the wrong way with his downforce set-up. He ended the evening three laps down on the leaders, and suspected that there was more to his plight than just a bad set-up.

"I think our problems were deeper than that," he admitted. "We just need to take a good look at what we missed."

And therein lies the one good thing about IndyCar's ultra-compressed schedule. As bad as a driver's weekend might be, the next race – and a chance at redemption – is rarely more than a week away. Toronto beckons...



DOUBLE BLOW FOR BOURDAIS

Sebastien Bourdais finished 14th, four laps down, due in part to a misunderstanding over a penalty. The Frenchman was given a stop/go for pitstop infraction during the caution period but was then forced to come in again after he accidentally served a drive-through instead.

RH-R TO GET ALL-NEW CAR

Andretti Autosport plans to build a new car for Ryan Hunter-Reay before the next oval race after the 2012 champion finished seven laps down in Texas. "Unfortunately, I think there's something wrong with this car – it's the same one we had at Indy," he said. "We're just going to come back with a different tub, a different everything. There's no excuse for this. I'm just glad I brought it back in one piece."

CARPENTER COPS THE FLACK

Ed Carpenter took responsibility for the CFH team's struggle to get its cars working on ovals. "We were in no way, shape, or form in contention," he said. "It's disappointing. We've been strong here for the past couple of years. We have good road-course cars right now. We just haven't been able to get this package sorted out for the ovals. A big part of that weight falls on my shoulders. I feel I need to do more to help these guys."

ELECTRICS BLIGHT PAGENAUD

Front-row starter Simon Pagenaud's hopes were dashed by an electrical problem. "We had an electrical issue with our weightjacker, which threw the balance of the car off until we got a chance to reset the system. But when we did that the engine shut down all the way into the pit stall. The guys continued to work on the car to make it better, but with our downforce set-up it was just not the best in traffic."



FOR FULL RESULTS, PAGE 44

Plato's Park masterclass

Jason Plato became the first driver to win twice in a weekend this season, and the first to succeed with 75kg of ballast. SCOTT MITCHELL watched it happen



THERE WAS REASON TO BE SCEPTICAL OF JASON

Plato's high expectations for his maiden season with Team BMR. He had, after all, joined a squad heading into only its third year proper of competition in the British Touring Car Championship, to drive a Volkswagen CC with just two reversed-grid victories to its name the previous year.

So when Plato called for a title challenge in year one, understandably some people wondered why he wasn't reaching for lower-hanging fruit. But at Oulton Park last weekend, the two-time champion gave the strongest demonstration yet that his lofty ambitions were plenty more than pipedreams.

From first practice it was evident that Plato was at ease in Cheshire. He historically goes well at Oulton, and was on pole the last two times the series used the Island configuration.

Record-breaking pace in both practice sessions preceded an even faster pace in qualifying that earned him pole, his seventh at the venue. Granted, Matt Neal and Andy Priaulx were within a tenth, but the first part of the job was done.

The manner in which that was translated into a crushing race-one victory, extending his all-time wins record to 91, should not be understated, particularly given how close the rest of the field was. Plato also executed the plan to grab race-two pole immaculately, setting the race's fastest lap with ease on the fourth tour.

Practice and qualifying were dress rehearsals for a race-one win earned on sheer speed and



precision, and that's not an easy combination to achieve to such a devastating effect on a circuit as tricky as Oulton. But Plato loves the track's natural composition, and the lack of mechanical corners – a proper driver's track, he says, one where a driver's feel and a car's balance make more difference than at most others because of the topography of the region.

"At Cascades, there's a crest and a bump and a camber change," he says. "Depending on where you position the car, depending on the balance you've got, you can use that to good or bad effect. Another one is Druids – there are some funny little bumps and undulations.

"Cascades is one of the most difficult corners in

the country to get right, and when you do it's lush. I tend to, at the beginning, when I've got good front-end grip, use a more traditional line and towards the end I'll use a slightly later, harder turn, and as the rear falls away you get a bit of oversteer. But you need the car working for you before you can do that.

"You brake late, go down the gears, come off the brakes, the car comes up and you turn the weight and it slides, but you don't correct it. You need confidence in the car to do that, you need a great car underneath you."

The Volkswagen CC certainly ticked that box last weekend. At least, Plato's did. He was up the road compared to team-mates Colin Turkington and



Race one kicked off
a perfect Sunday
for Plato



Plato licked them
at Oulton Park

BTCC

Oulton Park (GB)

June 7

Round 4/10

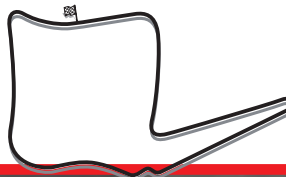

Cascades is one of the most difficult corners in the UK to get right, and when you do it's lush

JASON PLATO



Shedden, with softs
and 75kg, earned
sixth in race one

Aron Smith, who weren't quite able to unlock the same level of performance as the man arrowing in on 100 BTCC race wins.

If Plato's race-one triumph was all about speed, race two – win number 92 – was about guile. Nobody had won with 75kg of ballast on board prior to last weekend, let alone won twice in a round this season, but it says a lot about the form of the BMR man that it didn't look an unlikely prospect going into race two.

That said, a Gordon Shedden challenge was expected, particularly with the Honda man running 33kg and the Civic Type-R looking extremely potent on a circuit that rewards a car strong in the braking zones. Once Plato held the lead at the start,

though, Shedden's task became a lot harder. Defending around Oulton isn't the toughest task a driver will face in his career, but if there's a job to do then it should be done right, and Plato was almost completely flawless as he bagged the first double win (in a race weekend) of the season.

"I thought, providing I could get into the lead and the balance was what I thought it would be, I could not be overtly defensive," Plato asserted. "About mid-distance, there was a turning point where my car started to come alive. I had a bit of understeer at the beginning but the balance was coming to me. Then Gordon made a little error at the hairpin, lost a couple of car lengths and that was it. I could arrive at the corner, not even looking,

and it allowed me to break the gap to where he was never within striking distance."

Shedden put it best: "My car was good; you just can't pass. Especially somebody as good as Jason."

To Shedden's credit, he'd put up his own strong rear-guard action in race one, admirably fighting off a string of cars to clinch sixth despite running with 75kg of ballast and the soft tyres.

Plato's feelings about the championship's mandated use of Dunlop's soft rubber are well documented, as is his honesty about how he approaches races in which he has to run the higher-degradation rubber: he often switches to conservation mode.

Oulton afforded a different approach. The soft tyre held up well, aided in the most part by the warmer temperatures compared to those experienced at the troublesome Donington Park round in April. Defence could turn into attack.

Plato compared the process of choosing the soft tyre to flipping a coin on Saturday, but this was largely tongue-in-cheek. He has formed an ominous partnership with engineer Carl Faux and the attention to detail is lacking in few areas, if any. The choice of the soft tyre is no exception.

"The perfect strategy, with the way the soft tyre is, is to run it in race three," explained Plato. "And the dilemma before the weekend we've done that twice. We can only do it one more time. So do we do it here? Or do we save it? My thoughts were we were going to be very fast, so let's make ▶

Tordoff finally took first win in BMW



► hay while the sun's shining. We decided not to go with our crazy set-up because the track temperature was coming up. So, providing I was gentle for the first four laps, I thought it would be OK. I figured we'd get fifth or sixth actually. I didn't think I was going to go backwards. I'm not surprised, I'm pleased it did what we thought it would."

Results like that come from meticulous preparation and a similar execution. So when Plato slotted into fifth behind Shedden and was able to keep team-mates Turkington and Smith at bay, it was job done – not for the first time this weekend.

The reward was the biggest points haul of anyone on a race weekend so far this season and, with it, the championship lead. Few could have left Cheshire or turned off their TVs without thinking that wasn't deserved.

"The big thing from the weekend is I'm really in tune with the car," Plato mused, having notched four wins in the first four rounds for the fourth time in his career.

"We're really getting the feel for what we want it to be like when I jump in. The doors to the blind alleys we're boarding up now. We're not totally sorted but we're in good shape.

"Had we not lost that win at Brands to a puncture, I'd be now be sat on five wins from the first four meetings. I don't think I've ever done that before. This is one of the best starts."

His jubilation contrasted starkly with a reflective Turkington after race three. Since taking the first

I needed this – it's been a tough start. People asked me all sorts of questions... Most were bollocks

ANDREW JORDAN

win of his own BMR career, the defending champion has been lacking a tenth or two, a pace deficit that has left him in point-accumulation mode while he tries to refine the balance of his CC.

Oulton was a trying weekend. Sixth in qualifying on Saturday was "pretty much where we've been all day" and a brake problem in race one left him last on the road and only 12th on the grid for race two. He rose to eighth, which became sixth in race three.

"Sometimes it goes your way and other times it doesn't," he reflected. "The weight had more of an effect that we thought, not on pace but on balance. I'm still looking for the last couple of tenths. That's the nature of the championship; it'll continue to ebb and flow. Hopefully we'll strike back at Croft."

Turkington's troubles mirrored those of Andrew Jordan's last year – a defending champion unable

to make significant progress on a tight track and therefore struggling to bank big points.

Jordan's title defence started to unravel in Cheshire 12 months ago, so it would be fitting if Oulton was the place where his current campaign with MG sparked into life. That was the attitude the 2013 champion was embracing on Sunday evening, after by far the most competitive showing since his switch to the Triple Eight team.

Triple Eight principal Ian Harrison said it was "a long game", and Jordan agreed, with fourth, third and second last weekend moving him into fourth in the points and well within range of new pacesetter Plato.

"The first three might well be key," he said of the opening rounds, where pace was lacking but the results were earned through sheer resilience.

"We're fully in the hunt and that really excites me.

"I needed this weekend. It's been a tough start to the year and people asked all sorts of questions, and it amuses me. Most of it was bollocks. But we're where we should be now."

All Jordan's maiden season in the MG factory line-up is lacking now is a win, and it was very close to arriving in race three at Oulton. A robust move on Neal earned him second at Lodge and he quickly closed down race leader Sam Tordoff, but couldn't launch a serious attack.

That allowed Tordoff, who left the MG squad for WSR over the winter, to clinch his first win in the team's BMW 125i M Sport, a breakthrough result after a difficult start. Tordoff initially slipped to third in the final race at Oulton, but that became second when poleman and early leader Adam Morgan was handed a drive-through penalty for a jump start in his Ciceley Racing Mercedes A-class.

Passing Neal at Old Hall after the Honda Civic Type-R had a wobble on some fluid at Lodge handed Tordoff the advantage, and the third-year BTCC racer didn't bat an eyelid as he resisted Jordan's late-race pressure. That meant the monkey was off his back – and it was a welcome boost for the WSR team after a catastrophic second race.

After Priaulx just missed out on pole on Saturday, he bagged a hard-earned podium in race one on Sunday, but collided with team-mate Rob Collard in race two (see right) and retired from the finale with a suspected engine problem.



Beating Smith to sixth was the peak for Turkington

FOR FULL RESULTS, PAGE 44

IN THE PADDOCK

SCOTT MITCHELL
FEATURES EDITOR

@ScottMitche1189



SEARCH 'BTCC BORING' ON TWITTER. It'll throw up quite a lot of results, especially from last weekend. It seems the racing on show did not best satisfy a portion of the television audience.

I'm not sure how motorsport's managed to get into this situation, but vultures are swift to start picking at the carcass of any race that isn't laden with overtakes.

Formula 1 is the chief victim of such a state of mind, but the BTCC rarely gets beaten with that stick. Not all races can be action-packed thrillers, but labelling the trio of races at Oulton boring has irritated me.

Watching on telly appeared to create a perception that they were processions. But TV's how we see them in the media centre. And these races weren't really dull.

A race with multiple lead changes is an uncommon scenario, but, more significantly, it is not a prerequisite for a good race. Of course, it helps, but why should a race live or die off the back of how many times the lead changed?

Jason Plato's pace in race one was exceptional and his drive remarkable in its execution. There was a nose-to-tail battle for second, with the championship leader fighting a rear-guard action just to hold



Close enough for you? JP beats 'Sheds' by 0.093s

sixth. Plato's winning margin in race two was 93 thousandths of a second.

That's almost as close as they come. And anyway, Sam Tordoff had to pass Matt Neal to win race three, before staving off Andrew Jordan – who pulled a robust move on Neal at Lodge to assume second.

I'm not trying to polish excrement and call it cheesecake. I'm calling it as I see it, and while I appreciate that fans are doing the same, I think it's a disservice to a venue like Oulton Park to criticise its place on the

calendar because the three races last weekend weren't overtaking-fests.

Oulton is a fantastic venue, a genuinely old-school circuit that challenges drivers like few others. Yes, it's tight, and no, it doesn't promote side-by-side racing in the way Rockingham or Silverstone National might. But who would want it to be different?

It's too easy to overlook the value of a circuit with real character. So what if the races didn't feature dozens of overtakes? I'll take that trade any time.

Priaulx sorry for clash with team-mate

THREE-TIME WORLD CHAMPION Andy Priaulx apologised to WSR team-mate Rob Collard for the clash that ruined both drivers' race two at Oulton Park.

Priaulx caught the sister BMW of Collard, who was running fourth, late on and attacked into the hairpin on the final lap, but the two made contact as Collard moved across to the left.

The left-rear toelink on Collard's 125i M Sport was broken in the impact, causing him to retire immediately, while Priaulx's car was also hobbled and he dropped to 15th.

"I had a go at Rob and we touched," Priaulx said. "He didn't see me, but I should have just settled for that position. I'll take the blame."

Collard accepted his team-mate's apology but admitted severe frustration after being robbed of a strong result from eighth on the grid, which would have marked a stark turnaround after qualifying down in 18th.

"I looked in my mirror and he was four or five car lengths behind. When I braked I just felt a massive hit on the rear," he said. "He's apologised but we could have had fourth, fifth and seventh."

Plato has eye on 100th win

JASON PLATO DOES NOT THINK his 100th British Touring Car Championship win will come this season after taking his all-time record win tally to 92 at Oulton.

The two-time champion said it was inevitable he would break the triple-digit barrier and said his BTCC career – now in its 17th campaign – was still several years from ending.

"It's coming and it'll happen at some point," he said of achieving his 100th win. "It won't be this year, I don't think it will."

"We've got eight more to get and it'll be great. I've got a three-year deal here so it might end up 120, who can tell?"

"I can look back and think, 'I was all right at that!' It's more for the kids. When they are older they can go, 'He was all right at that, wasn't he?' It would probably stay for quite some time that, I would think."



THE TITLE CHASE

Such is the nature of this year's title fight that it only took Plato's victory in race one to take the points lead. It still remains very close behind, although Turkington has lost ground

TOTAL NUMBER OF POINTS SCORED

PLATO	157	
SHEDDEN	154	
NEAL	149	
JORDAN	144	
TURKINGTON	124	

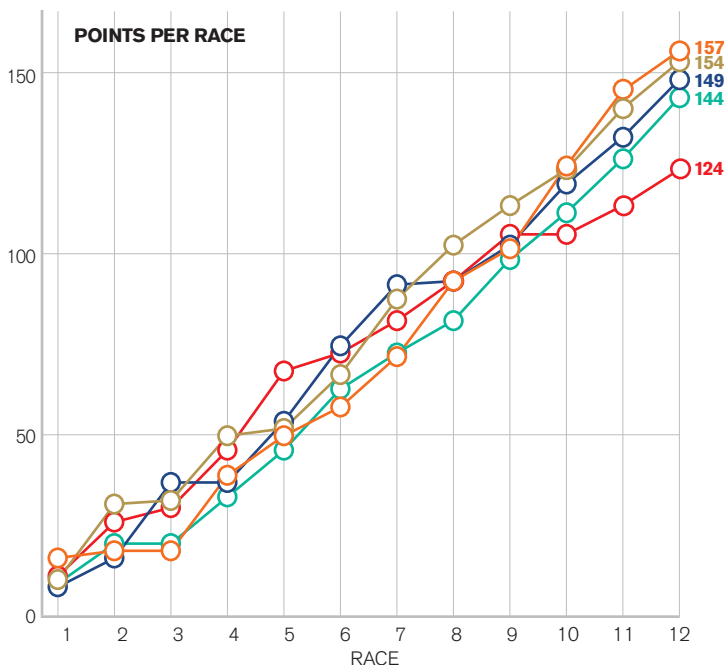

PARAS RUN ONE Q50

The Support Our Paras Racing team ran just one car for its first weekend without Infiniti's manufacturer support. Derek Palmer Jr scored the team's first independents' points since the Japanese marque withdrew last month, with a best overall finish of 19th. The team is understood to be in advanced negotiations, as it looks to run a second Q50 for the rest of the season.

COOK JST LEAD GROWS

Josh Cook's Jack Sears Trophy lead was extended with two class victories over the weekend. The Power Maxed Racing man had a difficult second race, but sandwiched race-two disappointment with two finishes as the leading rookie driver. Alex Martin marked his return from back surgery with the other JST victory.

DUNLOP'S NEW TYRE

Series tyre supplier Dunlop introduced a new medium-compound tyre for the three races at Oulton Park, the first made by the company's German plant since it ceased UK production. The new control tyre is slightly more durable, but also offered a slight pace advantage estimated at around 0.1-0.15s. It has confirmed there will be no changes to the softer-compound tyre this season.

MSA FORMULA OULTON PARK, JUNE 6-7
RD 4/10

Collard and Norris win again, as Fielding joins in

WITH SO MANY RACE WINNERS SO FAR IN MSA Formula, it's tough to work out just who will be the main title protagonists.

Ricky Collard and Lando Norris took a win apiece to cement their championship ambitions, with Sennan Fielding finally scoring his maiden series victory.

Norris streaked clear in qualifying to put his Carlin Mygale machine on pole for the opener, but Collard made by far the better getaway when the light went out. Norris managed to quickly nip past the Double R machine of Rafael Martins before a safety car was called. Last year's F3 Cup champion Toby Sowery, who earlier shunted at Druids in qualifying, had spun his Fortec Motorsports car at Hislops chicane when an oil leak ran on to the rear tyres.

Collard performed another fine restart, with Martins and Colton Herta tussling for third. The American got ahead up the inside at Island hairpin on the third tour, and defended from Martins' attempt at the cutback. As Norris reeled in and began squabbling with Collard in the closing stages, Herta saw the script being written for his maiden win, but Collard defended staunchly to the flag.

After a disappointing opening race, Zip Young Guns JHR racer Fielding sat on the front row for the second encounter. It was his best chance of victory if his car, which had been burdened with woes in previous rounds, could hold up. It did.



Collard (r) and Norris are the men to beat



R3 winner Norris hides from the spray

The race was rather uneventful, but Fielding didn't care as he made a better start than poleman Daniel Baybutt to lead into Old Hall. He streaked clear to win by over two seconds from the impressive Matheus Leist. Local racer Baybutt, Daniel Ticktum and Petru Florescu all dived for the final podium spot with Fortec racer Ticktum grabbing it on another frustrating weekend after an excellent start to the year.

The most entertaining action in the final race was completed in the opening two laps. Both Norris and Collard were a class above the rest but they were delayed by an early safety car. Firstly, Herta got it all wrong up the inside at Island hairpin, locking up and spearing into the side of the innocent Martins. The next time around, drivers hadn't learnt. Leist opted not to pull out of a move up the inside of Jack Barlow at Island, the pair colliding on the corner's exit, triggering a safety car. Leist opted to continue with a mangled front wing and defended staunchly from the attentions of Ticktum to the flag, only to be later disqualified for poor driving standards.

Fielding, who started 10th, put his car in the

right places at the right times to make his way up to third and pull away from Leist to score a second podium of the weekend as Norris comfortably headed Collard.

"It's tough to overtake around here so doing that in the opening race wasn't on," Norris said later. "We had the pace with a gap to the rest. Ricky is the one I'm looking to beat right now."

Collard added: "To be disappointed with second in the final race shows the pace and ability of the car throughout the weekend."

● Russell Hayes

Results

Race 1 (13 laps) 1 Ricky Collard 20m56.608s (82.90mph);

2 Lando Norris +0.447s; 3 Colton Herta; 4 Rafael Martins;

5 Matheus Leist; 6 Jack Barlow. **FL** Herta 1m23.195s (96.32mph).

Race 2 (15 laps) 1 Sennan Fielding 20m58.718s (95.50mph);

2 Leist +2.032s; 3 Daniel Ticktum; 4 Dan Baybutt; 5 Barlow;

6 Herta. **FL** Leist 1m22.807s (96.77mph). **Race 3 (13 laps)**

1 Norris 20m00.554s (86.77mph); 2 Collard +3.751s; 3 Fielding;

4 Ticktum; 5 Petru Florescu; 6 Toby Sowery. **FL** Norris 1m22.482s

(97.16mph). **Points** 1 Collard, 175; 2 Norris, 168; 3 Ticktum, 149;

4 Leist, 134; 5 Sandy Mitchell, 89; 6 Fielding, 87.

GINETTA JUNIORS OULTON PARK, JUNE 6-7 RD 4/10

Sweet Caroline does the double

JAMIE CAROLINE WAS THE CLASS OF THE Ginetta Junior field at Oulton Park as he claimed two comfortable victories to open his 2015 account.

Caroline had been a regular podium finisher in the opening rounds of the season, but had just missed out on the win. That was until the Cheshire weekend.

Qualifying showed he was in good form as he was piped to pole by Dave Wooder by just a tenth-of-a-second. Caroline then grabbed the lead in the opener with a brilliant move on Wooder at Old Hall and never looked back, winning by 8.6 seconds despite a wide moment at Cascades.

The HHC Motorsport driver dominated

again in race two, claiming the lead at Old Hall but he escaping a nervy finish as the race concluded behind the pace car after a hefty shunt for Rowan Bailey at Deer Leap.

Behind Caroline, Dan Zelos topped a cluster of cars fighting for the podium spots in the opener after Wooder retired with a mechanical problem and Kyle Hornby's bonnet came open. Points leader Senna Proctor took a hard-fought third after Thruxton double winner Sophia Floersch shoved Jonathan Hadfield out of the way at Island on the final tour.

BMR-supported Proctor was runner-up second time around as he also passed team-mate Zelos at Old Hall.

● Stephen Lickorish



Two out of two for Caroline

Results (both 8 laps)

Race 1 1 Jamie Caroline 14m01.072s (76.22mph); 2 Dan

Zelos +8.693s; 3 Senna Proctor; 4 Sophia Floersch; 5 Lewis

Brown; 6 Jonathan Hadfield. **FL** Caroline 1m44.168s

(76.93mph). **Race 2** 1 Caroline 15m47.855s (67.64mph);

2 Proctor +0.315s; 3 Zelos; 4 Floersch; 5 Brown; 6 Hadfield.

FL Brown 1m43.555s (77.38mph). **Points** 1 Proctor, 204;

2 Caroline, 183; 3 Zelos, 176; 4 Floersch, 163; 5 Billy Monger,

148; 6 Hadfield, 144.

GINETTA GT4 SUPERCUP OULTON PARK, JUNE 6-7 RD 4/10

HHC duo shares wins after clash

RELATIONS BETWEEN HHC MOTORSPORT TEAM-mates and championship rivals Jamie Orton and Carl Breeze took a turn for the worse at Oulton Park as the pair clashed in race two. This resulted in on-the-road winner Orton losing victory thanks to a penalty.

Breeze passed Orton on the second lap when the poleman ran wide at Old Hall, but Orton sought his revenge into Hislops on the next lap. Orton lunged at Breeze, who closed the door and the duo made contact. Orton was forced to cut the corner and gained the place. Predictably, former champion Breeze wasn't happy with the move.

"Who made the corner? Me. Who gained the advantage? He did," said Breeze. "It's a difficult situation because I do get on well with Jamie."

Officials agreed with Breeze and demoted Orton to second for gaining an unfair advantage.

The team-mates have proved to be the class of the field this year and this was demonstrated



Orton lost his race-two victory

in the first race. Orton led throughout but the pair traded record lap times as Breeze closed to 0.6 seconds by the flag.

Century Motorsport's Tom Oliphant took third after an eventful race. He claimed the place with a great move on Will Burns round the outside of Old Hall on the opening lap but was later hampered by a bonnet catch working its way loose.

Oliphant's race was more straightforward second time around as he again completed the podium, while his team-mate, ex-BTCC driver

Ollie Jackson, took a brace of hard-fought fourth places, his best in the series.

● Stephen Lickorish

Results (both 15 laps)

Race 1 1 Jamie Orton 21m34.927s (92.83mph); 2 Carl Breeze +0.619s; 3 Tom Oliphant; 4 Ollie Jackson; 5 Michael Caine; 6 Reece Somerfield. **FL Breeze 1m25.641s (93.57mph).**

Race 2 1 Breeze 21m47.418s (91.94mph); 2 Orton +0.070s; 3 Oliphant; 4 Jackson; 5 Caine; 6 Somerfield. **FL Orton 1m26.070s (93.11mph).** **Points 1 Breeze, 337;** 2 Orton, 304; 3 Oliphant, 255; 4 Will Burns, 249; 5 Caine, 233; 6 Somerfield, 200.



Rivett fought off attack to win opener

CLIO CUP UK OULTON PARK, JUNE 6-7 RD 4/9

Whorton-Eales settles for points

IT WAS A CONTRASTING WEEKEND FOR TWO OF the title protagonists as points leader Ant Whorton-Eales took two seconds, while Ashley Sutton only had a fifth to show for his efforts.

Whorton-Eales claimed second in race one after losing out to series veteran Paul Rivett at the start, but made amends with a win later.

However, the SV Racing driver was later demoted to second after pushing Pyro racer Ash Hand out of the way at Cascades early on. Despite this, he still extended his points advantage because of Sutton's tough weekend.

He finished fifth in the opener after contact when battling with 20Ten's Jordan Stilp, but race two was even worse.

Sutton retired with a damaged radiator after striking a tyre stack that had landed in the middle of the road after being hit by Rivett.

Stilp took third in race two, while Jon Maybin was another driver demoted for contact – dropping from an excellent fourth to seventh.

● Stephen Lickorish

Results (both 12 laps)

Race 1 1 Paul Rivett 19m07.615s (83.79mph); 2 Ant Whorton-Eales +0.178s; 3 Ash Hand; 4 Jordan Stilp; 5 Ashley Sutton; 6 Charles Ladell. **FL Sutton 1m34.603s (84.71mph).**

Race 2 1 Hand 19m17.895s (83.05mph); 2 Whorton-Eales +0.218s; 3 Stilp; 4 Rivett; 5 Ladell; 6 Jack Mitchell. **FL Hand 1m34.948s (84.40mph).** **Points 1 Whorton-Eales, 229;** 2 Hand, 208; 3 Sutton, 182; 4 Rivett, 170; 5 Stilp, 161; 6 Mitchell, 132.

PORSCHE CARRERA CUP GB OULTON PARK, JUNE 6-7 RD 3/8

Meadows halts dominant Cammish

A FIRST VICTORY OF THE SEASON DID LITTLE to lighten Michael Meadows' spirits as Dan Cammish extended his lead of the championship with another victory.

Yorkshireman Cammish had dominated the early stages of the season, scoring victory in three out of four races ahead of the weekend in Cheshire. His excellent form continued in the early stages at Oulton Park, setting the quickest times in practice and then qualifying with a gap of a quarter of a second to closest challenger Nicholas Latifi.

It didn't take long for former British Formula Ford champion Cammish to assert his authority on Saturday's opener, leading by over a second by the end of the second tour. Stephen Jelley became his closest rival after the ex-GP2 Asia racer made a better getaway than Latifi, with Meadows unable to mount a challenge to the front trio.

Latifi was insistent on getting ahead of Jelley, and on two successive occasions risked putting himself out of contention. The Canadian, more used to the braking forces in his Formula Renault 3.5 machine, outbraked himself firstly into the Hislops chicane, forcing him to go straight on and cut it completely. He lined up for another go the next time around, managing

to run side-by-side with Jelley's Team Parker-run racer. But again the braking was all wrong and it forced Jelley to take aversive action over the grass. It was third time lucky though as he finally made the move stick the next time around.

It was good timing too, as the Pro-Am2 battle between Peter Kyle-Henney and Graeme Mundy quickly escalated on lap eight. The pair went side-by-side around Old Hall and made contact. It sent Kyle-Henney on to the grass, tipping him into a barrel roll. Meadows' luck was once again out, an engine hose popping off and spewing fluid on to the track. He pitted for the team to empty their bottles of water into the car, but his hopes of a podium were over. From the restart, Latifi pressured Cammish to the flag. Jordan Witt took ProAm1 honours with Scott Marshall on top in ProAm2.

Meadows made up for his earlier disappointment with an assured race-two victory. He battled with Cammish throughout but was always in control of his advantage. "That was the most entertaining race I've had in the Carrera Cup," Meadows said. "It's the first time I've had the chance to dice with Dan. But my title chances are already over."

Latifi tussled entertainingly with Webster for third until the flat spot on his front right tyre gave way causing a puncture at Hislops on the penultimate tour. Leonard took ProAm1 victory with Mundy recovering from his race one contact, a comfortable ProAm2 victor.

● Russell Hayes

Results

Race 1 1 Daniel Cammish, 16 laps in 25m40.950s; 2 Nicholas Latifi, +0.367s; 3 Stephen Jelley; 4 Josh Webster; 5 Dino Zamparelli; 6 Tom Sharp. **Race 2 1 Michael Meadows, 18 laps in 25m03.317s;** 2 Cammish, +0.333s; 3 Webster; 4 Sharp; 5 Zamparelli; 6 Jelley. **Points 1 Cammish, 119;** 2 Jelley, 92; 3 Webster, 88; 4 Meadows, 73; 5 Latifi, 55; 6 Zamparelli, 55.



Meadows broke 2015 duck in second race

Blancpain Sprint

Zolder (B)
June 6-7

Round 4/8

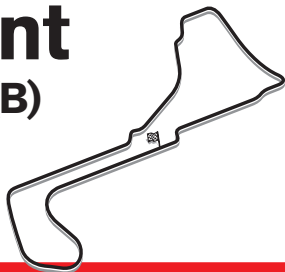

WORLD ON WHEELS

@CIRCUIT Zolder

WRT Audis led most laps of both races



Vanthoor and Frijns dominate again

IS THERE ANY STOPPING LAURENS VANTHOOR AND Robin Frijns right now? The best driver line-up in the Blancpain Sprint Series – who happen to drive for the best team in WRT Audi – took another double victory at Zolder last weekend, and quite frankly look unbeatable.

Vanthoor claimed another pole position – he set two laps good enough for top spot – and their WRT Audi R8 LMS ultra led every lap of the pair of one-hour races with the exception of the odd tour during the mid-race pitstop cycles. Victories by 5.5 seconds in the qualifying race and 9.9 seconds in the Main Race almost didn't do their domination justice.

Even the driver pairings who might have pushed the Audi duo a bit harder weren't convinced that they could have beaten them.

Marco Seefried edged towards Frijns in the last laps of the first race on Saturday in the Rinaldi Ferrari 458 Italia that he shared with Norbert Siedler. WRT reckoned the Italian car, back at the ride height with which it started the season on this category D circuit in the Balance of Performance charts, was going to be a real threat on Sunday.

WRT never got to find out, because Seefried was tapped on his left-rear corner by Vincent Abril's HTP Bentley going into the first corner and spun into the gravel. Even so, Seefried wasn't sure the Ferrari would have been able to mount a race-long challenge.



Vanthoor and Frijns were uncatchable

"I noticed on the grid that I was on sticker tyres and Frijns was on used tyres," explained the German. "If I'd had a chance in the first four laps or so, maybe I would have been able to take it."

"But if I could have beaten him on the track, I'm not sure we could have stayed ahead in the pits. We are a little team and improving all the time, but they are consistently so fast at pitstops."

The other duo that on paper looked as though they could have taken the fight to Vanthoor and Frijns were BMW Team Brazil drivers Atila Abreu and Valdeno Brito. Their weekend was undone by a track-limits violation that robbed Brito of a time that would have put them through to the final session of qualifying.

As it was, they lined up 15th on the grid, but Brito was still able to propel himself to sixth on the first lap, thanks in part to a start-line accident in which he was implicated, and that removed two of the four WRT Audis from the race.

Abreu and Brito finished the opening encounter fifth in their BMW Z4 and third in the full-points encounter after losing out to the best of the HTP Bentley Continental GT3s shared by Abirl and Maximilian Buhk in the pits on Sunday. But could they have beaten Vanthoor and Frijns?

"No way!" reckoned Abreu. "In the past four races, they have beaten us by 20-25s – that's half a second a lap. The Audi is a quicker car than the BMW and they have two strong drivers."

Vanthoor and Frijns now lead the championship by 27 points despite missing the Nogaro opener after a crash in qualifying. But they are insistent that they are not counting their chickens yet, and pointed to the events of last weekend as evidence. WRT might have dominated on home ground with its lead car, but it had a pretty disastrous weekend otherwise.

The first-corner shunt on Saturday put the #3 Audi out of the race and #4 out for the weekend. The chance of a decent result with the #2 entry on Sunday disappeared when Christopher Mies was penalised for a jump start.

Vanthoor, who got away with an accident in practice at Brands Hatch last month, knows things can change rapidly.

"Everything is going well right now," he said, "but you can full flat on your face in a fraction of a second."



Abreu/Brito BMW took fifth and third

FOR FULL RESULTS, PAGE 44

IN THE PADDOCK

GARY WATKINS
CONTRIBUTOR

@gazzasportscars



EVERYONE LOVES ZANDVOORT, BUT is it a worthy replacement for Baku? The answer is of course not. The Azerbaijan street race was much more than just a finale of the BSS (and before that the FIA GT Series), and the World Challenge tag line explained why.

Look at the additional cars that turned up each year, lured by start money — €20,000 per car — and a healthy prize fund. There were always some decent teams fielding top driver line-ups aiming to claim a slice of glory and a wodge of cash.

It is likely that Macau's purchase of FIA World Cup status for its end-of-season GT extravaganza would have detracted from Baku (though we are still waiting on details about the Far Eastern race and what its fancy name actually means). Even

so, Zandvoort is unlikely to be a patch on what the Azerbaijan event would have been. It will, unfortunately, be just another round of the championship, and on present form Laurens Vanthoor and Robin Frijns will have wrapped up the title before we reach the Dutch seaside town.

That's not to blame the Stephane Ratel Organisation in any way. Such events in nations new to motorsport are fickle by nature, especially when they are prey to fluctuations in the price of oil.

I'm just glad that I made it to Azerbaijan for one of the two World Challenge events. There was a frontier feel to the 2013 race, similar to but not as extreme as the Zhuhai round of the BPR-run International GT Endurance Series way back in 1994. I always enjoy visiting new circuits, especially street tracks, but the fact that it was only the second ever motor race in Azerbaijan lent a certain frisson to the atmosphere.

Zandvoort, I'm afraid, isn't going to have that. Nor is it going to have those extra cars that brought the BSS grid up to where it should be in terms of quantity and quality.

Azerbaijan's Baku
race will be missed

Dillmann claims class victory on series debut

FORMULA RENAULT 3.5 frontrunner Tom Dillmann claimed victory in the Silver Cup at Zolder on his GT debut, after being called up at the last minute to race the second HTP Motorsport Bentley.

The Frenchman was brought into the squad to drive alongside Jules Szymkowiak when Olivier Lombard encountered sponsorship problems ahead of the Belgian event. Dillmann's debut followed a try-out with the team

in January this year.

The GP2 race winner qualifies as a silver-rated driver, making him eligible for the class that caters for drivers of that rating aged 25 or below at the start of the year.

He revealed he had planned a move into GTs in 2015 following his third-place finish in last year's Porsche Carrera Cup France. This was before he was offered a paid-for seat in FR3.5 for the season with the Carlin squad.

"I was aiming for GTs because that is the best way to become a professional, but then I got a really good offer in FR3.5," explained the 26-year-old.

"I definitely want to do more in GT racing this season," he said.

"It would make sense to continue with HTP and Bentley, but I am open to other offers. I have no clash for the Spa 24 Hours and would like to do it."

FR3.5 racer won for
HTP Bentley squad

KOX BACK TO REITER

Peter Kox made a return to the Reiter Lamborghini squad just two months after he announced he was ending a relationship with the German team that had spanned 15 years. The Dutchman replaced Nicky Catsburg, who was racing in the Moscow World Endurance Championship event, alongside Albert Thurn und Taxis in the Lamborghini Gallardo LP560 R-EX run by Hans Reiter's team. "Hans and I reminded each other that we are still friends," said Kox. "But this does not mean I am returning to the team."

22 CARS FOR MOSCOW

The entry for the Moscow round of the BSS next month is set to swell from the 18 full-season entries present at Zolder to 22 cars. Series boss Stephane Ratel has yet to reveal the identity of the teams running the additional cars.

AND 70 CARS FOR SPA?

The entry for the Spa 24 Hours round of the Blancpain Endurance Series could swell to as many as 70 cars, according to Ratel. He expects to have eight additional entries on top of the 62 full-season entries.

BIG NUMBER

96.4

Percentage of the total laps that Vanthoor and Frijns have led this year in the four BSS races in which they have taken part.

Baku race replaced by Zandvoort

THE BAKU ROUND OF THE BSS has been cancelled and replaced by a race at Zandvoort.

Series boss Stephane Ratel revealed that the notification from the organiser of the Azerbaijan street race that was scrapping what would have been the third event in a three-year deal was a "big surprise". He explained that the International Concept Event Azteknika had cited economic reasons, including the drop in oil prices as well as the

financial pressures of staging the new Formula 1 Grand Prix in 2016.

"When the F1 race was announced, I wasn't expecting the race to happen this year, but then they announced that it would on the podium last year," said Ratel. "I hadn't heard anything for a while, so I started shaking their tree, and they came back to me with this news."

The Zandvoort finale will take place on October 11, two weeks before the scheduled date for Baku.



RESULTS ROUND-UP

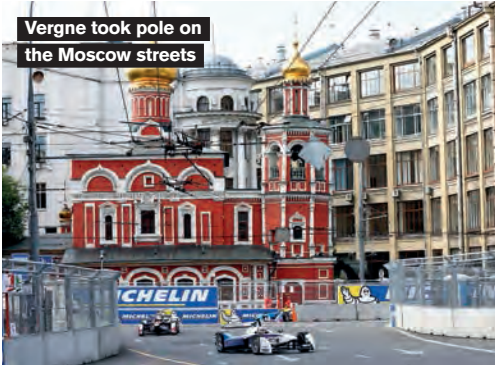

Vergne took pole on the Moscow streets

FORMULA E

ROUND 9/10 MOSCOW (RUS), JUNE 6 (35 LAPS – 49.803 MILES)

1 Nelson Piquet Jr (BR) China Racing (Campos)	43m18.867s
2 Lucas di Grassi (BR) Audi Sport Abt	+2.012s
3 Nick Heidfeld (D) Venturi (Signature)	+11.548s
4 Jean-Eric Vergne (F) Andretti Autosport	+12.416s
5 Daniel Abt (D) Audi Sport Abt	+25.626s
6 Salvador Duran (MEX) Amlin Aguri	+28.960s
7 Antonio Felix da Costa (P) Amlin Aguri	+30.529s
8 Nicolas Prost (F) Team e.dams Renault	+31.556s
9 Sebastien Buemi (CH) Team e.dams Renault	+40.050s
10 Justin Wilson (GB) Andretti Autosport	+46.320s
11 Jerome d'Ambrosio (B) Dragon Racing	+51.474s
12 Karun Chandhok (IND) Mahindra Racing (Carlin)	+52.493s
13 Jaime Alguersuari (E) Virgin Racing	+55.810s
14 Stephane Sarrazin (F) Venturi (Signature)	+56.715s
15 Loic Duval (F) Dragon Racing	+1m18.763s
16 Bruno Senna (BR) Mahindra Racing (Carlin)	-1 lap
17 Vitantonio Liuzzi (I) Trulli (Super Nova)	-1 lap
18 Jarno Trulli (I) Trulli (Super Nova)	32 laps-rear wing
19 Antonio Garcia (E) China Racing (Campos)	-3 laps
R Sam Bird (GB) Virgin Racing	24 laps-accident in first car; no power left in second

Winner's average speed 68.988mph.
Fastest lap Buemi, 1m11.679s, 71.465mph.

QUALIFYING

1 Vergne, 1m09.429s; 2 Piquet, 1m09.449s; 3 di Grassi, 1m09.685s; 4 Buemi, 1m09.826s; 5 d'Ambrosio, 1m09.967s; 6 Prost, 1m10.043s; 7 Abt, 1m10.075s; 8 Heidfeld, 1m10.098s; 9 Trulli, 1m10.145s; 10 Duran, 1m10.257s; 11 Bird, 1m10.365s; 12 Wilson, 1m10.398s; 13 Garcia, 1m10.537s; 14 da Costa, 1m10.617s; 15 Senna, 1m10.688s; 16 Chandhok, 1m10.697s; 17 Alguersuari, 1m10.941s; 18 Duval, 1m11.141s; 19 Liuzzi, 1m11.967s; 20 Sarrazin, 1m10.190s*.
* = excluded from qualifying.

CHAMPIONSHIP

1 Piquet, 128; 2 di Grassi, 111; 3 Buemi, 105; 4 Prost, 82; 5 d'Ambrosio, 77; 6 Bird, 68; 7 Vergne, 55; 8 da Costa, 51; 9 Abt, 32; 10 Heidfeld, 31.



Da Costa raced to P7 for Amlin Aguri

INDYCAR SERIES



Andretti was best Honda finisher

ROUND 8/15 TEXAS MOTOR SPEEDWAY (USA), JUNE 6 (248 LAPS – 360.840 MILES)

1 Scott Dixon (NZ) Chip Ganassi Racing Dallara-Chevrolet	1h52m47.8511s
2 Tony Kanaan (BR) Chip Ganassi Racing Dallara-Chevrolet	+7.8000s
3 Helio Castroneves (BR) Team Penske Dallara-Chevrolet	+9.9446s
4 Juan Pablo Montoya (CO) Team Penske Dallara-Chevrolet	+10.4608s
5 Marco Andretti (USA) Andretti Autosport Dallara-Honda	+26.0947s
6 Carlos Munoz (CO) Andretti Autosport Dallara-Honda	-1 lap
7 Charlie Kimball (USA) Chip Ganassi Racing Dallara-Chevrolet	-1 lap
8 Ryan Briscoe (AUS) Schmidt Peterson Motorsports Dallara-Honda	-1 lap
9 James Jakes (GB) Schmidt Peterson Motorsports Dallara-Honda	-1 lap
10 Gabby Chaves (CO) Bryan Herta Autosport Dallara-Honda	-2 laps
11 Simon Pagenaud (F) Team Penske Dallara-Chevrolet	-2 laps
12 Sage Karam (USA) Chip Ganassi Racing Dallara-Chevrolet	-3 laps
13 Will Power (AUS) Team Penske Dallara-Chevrolet	-4 laps
14 Sebastien Bourdais (F) KVSH Racing Dallara-Chevrolet	-4 laps
15 Graham Rahal (USA) Rahal Letterman Lanigan Racing Dallara-Honda	-5 laps
16 Takuma Sato (J) AJ Foyt Enterprises Dallara-Honda	-5 laps
17 Pippa Mann (GB) Dale Coyne Racing Dallara-Honda	-6 laps
18 Ryan Hunter-Reay (USA) Andretti Autosport Dallara-Honda	-7 laps
19 Stefano Coletti (MC) KV Racing Dallara-Chevrolet	-9 laps
20 Tristan Vautier (F) Dale Coyne Racing Dallara-Honda	156 laps-cv joint
21 Josef Newgarden (USA) CFH Racing Dallara-Chevrolet	149 laps-engine
22 Ed Carpenter (USA) CFH Racing Dallara-Chevrolet	147 laps-engine
23 Jack Hawksworth (GB) AJ Foyt Enterprises Dallara-Honda	62 laps-handling

Winner's average speed 191.940mph.
Fastest lap Power, 24.1743s, 216.676mph.

QUALIFYING

1 Power, 218.519mph; 2 Pagenaud, 218.441mph; 3 Castroneves, 218.069mph; 4 Munoz, 217.831mph; 5 Montoya, 217.530mph; 6 Rahal, 217.438mph; 7 Dixon, 217.411mph; 8 Kanaan, 217.337mph; 9 Kimball, 217.323mph; 10 Karam, 216.920mph; 11 Andretti, 216.876mph; 12 Jakes, 216.864mph; 13 Sato, 216.686mph; 14 Newgarden, 216.210mph; 15 Carpenter, 216.197mph; 16 Vautier, 215.929mph; 17 Hawksworth, 215.621mph; 18 Bourdais, 215.303mph; 19 Briscoe, 215.162mph; 20 Chaves, 215.146mph; 21 Hunter-Reay, 215.026mph; 22 Mann, 214.654mph; 23 Coletti, 211.930mph.

CHAMPIONSHIP

1 Montoya, 348; 2 Power, 313; 3 Dixon, 305; 4 Castroneves, 286; 5 Rahal, 261; 6 Andretti, 255; 7 Bourdais, 244; 8 Kanaan, 215; 9 Newgarden, 215; 10 Kimball, 214.

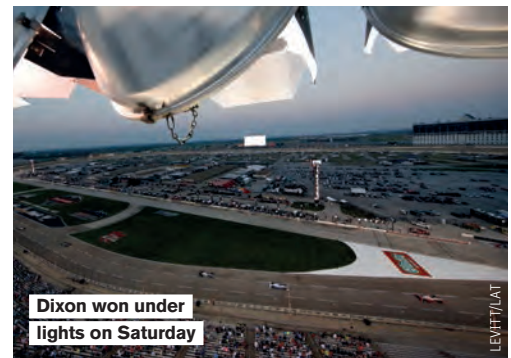

Dixon won under lights on Saturday

BRITISH TOURING CAR CHAMPIONSHIP

ROUND 4/10 OULTON PARK (GB), JUNE 7 RACE 1 (14 LAPS – 31.164 MILES)

1 Jason Plato (GB) Team BMR Volkswagen CC	21m14.936s
2 Matt Neal (GB) Honda (Dynamics) Honda Civic Type-R	+1.322s
3 Andy Priaulx (GB) WSR BMW 125i M Sport	+2.789s
4 Andrew Jordan (GB) MG (Triple Eight) MG6	+3.696s
5 Aron Smith (IRL) Team BMR Volkswagen CC	+5.187s
6 Gordon Shedden (GB) Honda (Dynamics) Honda Civic Type-R	+6.439s
7 Jack Goff (GB) MG (Triple Eight) MG6	+7.582s
8 Tom Ingram (GB) Speedworks Motorsport Toyota Avensis	+8.807s
9 Sam Tordoff (GB) WSR BMW 125i M Sport	+10.432s
10 Dave Newsham (GB) Power Maxed Racing Chevrolet Cruze	+12.527s
11 Adam Morgan (GB) Ciceley Racing Mercedes A-Class	+13.924s
12 Josh Cook (GB) Power Maxed Racing Chevrolet Cruze	+15.197s
13 Rob Collard (GB) WSR BMW 125i M Sport	+16.841s
14 Martin Depper (GB) Eurotech Racing Honda Civic	+17.870s
15 Rob Austin (GB) Rob Austin Racing Audi A4	+20.001s
16 Warren Scott (GB) Team BMR Volkswagen CC	+21.296s
17 Aiden Moffat (GB) Laser Tools Racing Mercedes A-Class	+22.607s
18 Hunter Abbott (GB) Rob Austin Racing Audi A4	+23.896s
19 Jeff Smith (GB) Eurotech Racing Honda Civic	+24.695s
20 Daniel Welch (GB) Welch Motorsport Proton Gen-2 Persona	+26.058s
21 Alex Martin (GB) Team Parker Racing Ford Focus	+27.127s
22 Derek Palmer Jr (GB) Support Our Paras Infiniti Q50	+28.493s
23 Simon Belcher (GB) Handy Motorsport Toyota Avensis	+30.610s
24 Mike Bushell (GB) AmD Tuning Ford Focus	+31.965s
25 Colin Turkington (GB) Team BMR Volkswagen CC	+33.753s
26 Andy Wilmot (GB) Welch Motorsport Proton Gen-2 Persona	13 laps
R Stewart Lines (GB) Houseman Racing Toyota Avensis	11 laps-accident
NS Kieran Gallagher (GB) Team Hard Toyota Avensis	0 laps-engine

Winner's average speed 87.99mph.
Fastest lap Plato, 1m26.462s, 92.68mph.

QUALIFYING

1 Plato, 1m25.484s; 2 Neal, 1m25.495s; 3 Priaulx, 1m25.555s; 4 Jordan, 1m25.937s; 5 Shedden, 1m25.937s; 6 Turkington, 1m25.976s; 7 A Smith, 1m25.992s; 8 Goff, 1m26.024s; 9 Ingram, 1m26.107s; 10 Morgan, 1m26.121s; 11 Tordoff, 1m26.134s; 12 Depper, 1m26.286s; 13 Newsham, 1m26.519s; 14 Cook, 1m26.536s; 15 Austin, 1m26.580s; 16 J Smith, 1m26.629s; 17 Scott, 1m26.644s; 18 Collard, 1m26.664s; 19 Moffat, 1m26.907s; 20 Martin, 1m27.383s; 21 Welch, 1m27.698s; 22 Belcher, 1m27.876s; 23 Abbott, 1m28.062s; 24 Lines, 1m28.275s; 25 Palmer, 1m28.767s; 26 Wilmot, 1m31.019s; 27 Gallagher, no time; 28 Bushell, 1m26.546s*. * = grid penalty.

RACE 2 (15 LAPS – 33.390 MILES)

1 Plato, 21m55.812s; 2 Shedden, +0.093s; 3 Jordan, +1.520s; 4 Neal, +7.403s; 5 Tordoff, +8.369s; 6 Morgan, +9.822s; 7 A Smith, +11.536s; 8 Turkington, +11.787s; 9 Goff, +12.276s; 10 J Smith, +15.654s; 11 Ingram, +16.116s; 12 Moffat, +23.715s; 13 Austin, +23.809s; 14 Depper, +23.865s; 15 Priaulx, +26.437s; 16 Scott, +29.363s; 17 Welch, +31.528s; 18 Martin, +32.011s; 19 Lines, +34.507s; 20 Palmer, +36.549s; 21 Belcher, +40.226s; 22 Bushell, +40.785s; 23 Abbott, +40.902s; 24 Wilmot, +51.121s; 25 Gallagher, -1 lap; 26 Cook, -1 lap; R Collard, 14 laps-accident; R Newsham, 0 laps-subframe.
Winner's average speed 91.35mph.
Fastest lap Tordoff, 1m26.768s, 92.35mph.

BLANCPAIN SPRINT SERIES

ROUND 3/7 ZOLDER (B), JUNE 6-7

MAIN RACE (39 LAPS – 96.982 MILES)

1 Robin Frijns (NL)/Laurens Vanthoor (B) WRT Audi R8 LMS ultra	1h00m26.711s
2 Vincent Abril (F)/Maximilian Buhk (D) HTP Motorsport Bentley Continental GT3	+9.944s
3 Atila Abreu (BR)/Valdeno Brito (BR) BMW Team Brasil (AH) BMW Z4 GT3	+13.609s
4 Caca Bueno (BR)/Sergio Jimenez (BR) BMW Team Brasil (AH) BMW Z4 GT3	+14.041s
5 Nikolaus Mayr-Melnhof (A)/Markus Winkelhock (D) Phoenix Racing Audi R8 LMS ultra	+19.289s
6 Jules Szymkowiak (NL)/Tom Dillmann (F) HTP Motorsport Bentley Continental GT3	+21.671s
7 Stephane Ortelli (MC)/Stephane Richelmi (MC) WRT Audi R8 LMS ultra	+22.635s
8 Filip Salaquarda (CZ)/Marco Bonanomi (I) ISR Audi R8 LMS ultra	+29.817s
9 Albert von Thurn und Taxis (D)/Peter Kox (NL) Reiter Engineering Lamborghini Gallardo LP 560-4 R-EX	+30.631s
10 Sean Walkinshaw (GB)/Craig Dolby (GB) MRS GT Racing Nissan GT-R Nismo GT3	+40.606s
11 Nicolas Armino (F)/Philipp Wlazik (D) Attempto Racing McLaren 650S GT3	+58.120s
12 Thomas Fjordbach (DK)/Anders Fjordbach (DK) ISR Audi R8 LMS ultra	+1m02.487s
13 Alexey Karachev (RUS)/Bernd Schneider (D) GT Russian Team Mercedes SLS AMG GT3	+1m02.962s
R Christopher Mies (D)/Enzo Ide (B) WRT Audi R8 LMS ultra	26 laps-spun off
R Kevin Estre (F)/Rob Bell (GB) Attempto Racing McLaren 650S GT3	5 laps-sensor
R Marco Seefried (D)/Norbert Siedler (A) Rinaldi Racing Ferrari 458 Italia GT3	1 lap-spun off
R Alexey Vasiliev (RUS)/Marko Asmer (EST) GT Russian Team Mercedes SLS AMG GT3	0 laps-accident
NS James Nash (GB)/Frank Stippler (D) WRT Audi R8 LMS ultra	0 laps-accident damage

Winner's average speed 96.268mph.

Fastest lap Vanthoor, 1m30.322s, 99.114mph.

In each car, first-named driver started race.

Grid formed by result of qualifying race.

QUALIFYING RACE (39 LAPS – 96.982 MILES)

1 Vanthoor/Frijns, 1h00m25.790s; 2 Siedler/Seefried, +5.563s; 3 Buhk/Abril, +12.707s; 4 Winkelhock/Mayr-Melnhof, +19.126s; 5 Brito/Abreu, +24.360s; 6 Dolby/Walkinshaw, +43.512s; 7 Jimenez/Bueno, +43.580s; 8 Dillmann/Szymkowiak, +43.739s; 9 Ide/Mies, +51.899s; 10 Bonanomi/Salaquarda, +1m01.867s; 11 Kox/von Thurn und Taxis, +1m02.303s; 12 Schneider/Karachev, +1m10.300s; 13 Asmer/Vasiliev, +1m11.824s; 14 A Fjordbach/T Fjordbach, +1m25.715s; 15 Wlazik/Armino, 29 laps-holed radiator; **R** Richelmi/Ortelli, 1 lap-accident damage; **R** Stippler/Nash, 0 laps-accident; **R** Bell/Estre, 0 laps-accident.

Winner's average speed 96.292mph.

Fastest lap Vanthoor, 1m30.530s, 98.887mph.

In each car, first-named driver started race.

QUALIFYING 3

1 Vanthoor, 1m28.716s; 2 Buhk, 1m28.962s; 3 Siedler, 1m28.983s; 4 Richelmi, 1m29.185s; 5 Estre, 1m29.253s; 6 Winkelhock, 1m29.257s; 7 Stippler, 1m29.265s; 8 Jimenez, 1m29.320s; 9 Dillmann, 1m29.423s.

QUALIFYING 2

Vanthoor, 1m29.086s; Siedler, 1m29.393s; Dillmann, 1m29.425s; Bell, 1m29.539s; Jimenez, 1m29.668s; Buhk, 1m29.697s; Richelmi, 1m29.715s; Stippler, 1m29.766s; Winkelhock, 1m29.812s; 10 Asmer, 1m29.856s; 11 Schneider, 1m29.877s; 12 Dolby, 1m29.925s; 13 Kox, 1m29.987s; 14 Wlazik, 1m30.098s; 15 Abreu, 1m30.152s; 16 Bonanomi, 1m30.281s; 17 A Fjordbach, 1m30.641s.

QUALIFYING 1

Abril, 1m29.986s; Estre, 1m30.066s; Seefried, 1m30.167s; Brito, 1m30.438s; Frijns, 1m30.582s; Bueno, 1m30.584s; Armino, 1m30.687s; Szymkowiak, 1m30.754s; Mayr-Melnhof, 1m31.091s; Walkinshaw, 1m31.338s; T Fjordbach, 1m31.635s; Ortelli, 1m31.706s; Vasiliev, 1m31.921s; Nash, 1m32.052s; Karachev, 1m32.210s; von Thurn und Taxis, 1m37.283s.

CHAMPIONSHIP

1 Vanthoor/Frijns, 68; 2 Abreu/Brito, 41; 3= Ortelli/Richelmi & Abril/Buhk, 34; 5 Maxime Martin/Dirk Muller, 31; 6 Bueno/Jimenez, 27; 7 Mayr-Melnhof/Winkelhock, 22; 8= Mies/Ide & Seefried/Siedler, 19; 10 Estre/Bell, 17.

WORLD TOURING CAR CHAMPIONSHIP

ROUND 5/12 MOSCOW RACEWAY (RUS), JUNE 7

RACE 1 (16 LAPS – 38.990 MILES)

1 Yvan Muller (F) Citroen Total Citroen C-Elysee WTCC	27m04.214s
2 Jose Maria Lopez (RA) Citroen Total Citroen C-Elysee WTCC	+2.933s
3 Gabriele Tarquini (I) Honda Racing Team JAS Honda Civic WTCC	+4.392s
4 Rob Huff (GB) Lada Sport Lada Vesta WTCC	+4.684s
5 Ma Qing Hua (PRC) Citroen Total Citroen C-Elysee WTCC	+7.082s
6 Tom Chilton (GB) ROAL Motorsport Chevrolet RML Cruze TC1	+8.724s
7 Norbert Michelisz (H) Zengo Motorsport Honda Civic WTCC	+10.394s
8 Tiago Monteiro (P) Honda Racing Team JAS Honda Civic WTCC	+12.809s
9 Sebastien Loeb (F) Citroen Total Citroen C-Elysee WTCC	+13.463s
10 Jaap van Lagen (NL) Lada Sport Lada Vesta WTCC	+14.044s
11 Nick Catsburg (NL) Lada Sport Lada Vesta WTCC	+18.239s
12 Hugo Valente (F) Campos Racing Chevrolet RML Cruze TC1	+20.870s
13 Rickard Rydell (S) Nika International Honda Civic WTCC	+24.517s
14 Mehdi Bannani (MA) Sebastien Loeb Racing Citroen C-Elysee WTCC	+33.791s
15 Gregoire Demoustier (F) Craft Bamboo Chevrolet RML Cruze TC1	+41.523s
16 Stefano D'Aste (I) Munnich Motorsport Chevrolet RML Cruze TC1	+1m06.562s
17 Tom Coronel (NL) ROAL M-sport Chevrolet RML Cruze TC1	15 laps-accident damage
NC John Filippi (F) Campos Racing Chevrolet RML Cruze TC1	9 laps

Winner's average speed 86.420mph.

Fastest lap Muller, 1m40.449s, 87.541mph.

QUALIFYING 3

1 Muller, 1m37.923s; 2 Lopez, 1m37.969s; 3 Tarquini, 1m38.091s; 4 Huff, 1m38.639s; 5 Chilton, 1m39.139s.

QUALIFYING 2

Lopez, 1m38.089s; Muller, 1m38.182s; Tarquini, 1m38.406s; Huff, 1m38.624s; Chilton, 1m38.785s; 6 Ma, 1m38.836s; 7 Valente, 1m38.873s; 8 Michelisz, 1m38.918s; 9 Catsburg, 1m39.047s; 10 Monteiro, 1m39.071s; 11 Loeb, 1m39.139s; 12 van Lagen, 1m39.195s.

QUALIFYING 1

Muller, 1m37.900s; Tarquini, 1m38.104s; Lopez, 1m38.207s; Huff, 1m38.325s; Valente, 1m38.518s; Michelisz, 1m38.579s; Loeb, 1m38.613s; Catsburg, 1m38.764s; Ma, 1m38.780s; van Lagen, 1m38.863s; Monteiro, 1m38.888s; Chilton, 1m38.948s; 13 Bannani, 1m39.172s; 14 Coronel, 1m39.550s; 15 D'Aste, 1m39.867s; 16 Rydell, 1m40.060s; 17 Filippi, 1m40.127s; 18 Demoustier, 1m39.951s*. * = grid penalty.

RACE 2 (16 LAPS – 38.990 MILES)

1 Monteiro, 27m12.922s; 2 Huff, +3.155s; 3 Michelisz, +5.549s; 4 Catsburg, +8.074s; 5 Ma, +12.188s; 6 Muller, +14.674s; 7 Loeb, +18.010s; 8 Valente, +20.803s; 9 Chilton, +20.968s; 10 Coronel, +21.207s; 11 Rydell, +21.686s; 12 Lopez, +24.659s; 13 Demoustier, +29.019s; 14 D'Aste, +31.584s; 15 Filippi, +34.404s; **R** Tarquini, 6 laps-accident; **R** van Lagen, 5 laps-suspension; **R** Bannani, 4 laps-exhaust.
Winner's average speed 85.959mph.
Fastest lap Huff, 1m40.894s, 87.155mph.

GRID FOR RACE 2

Decided by qualifying, but with the top 10 reversed.

CHAMPIONSHIP

1 Lopez, 199; 2 Muller, 164; 3 Loeb, 135; 4 Monteiro, 102; 5 Ma, 84; 6 Michelisz, 82; 7 Tarquini, 76; 8 Chilton, 55; 9 Huff, 41; 10 Bannani, 40.



GRID RACE 2

1 Plato; 2 Shedden; 3 Jordan; 4 Priaulx; 5 Neal; 6 J Smith; 7 A Smith; 8 Collard; 9 Tordoff; 10 Morgan; 11 Goff; 12 Moffat; 13 Turkington; 14 Depper; 15 Ingram; 16 Scott; 17 Cook; 18 Newsham; 19 Austin; 20 Abbott; 21 Bushell; 22 Martin; 23 Lines; 24 Welch; 25 Belcher; 26 Palmer; 27 Wilmot; 28 Gallagher.

RACE 3 (15 LAPS – 33.390 MILES)

1 Tordoff, 22m02.470s; 2 Jordan, +0.264s; 3 Neal, +0.766s; 4 Shedden, +2.997s; 5 Plato, +3.137s; 6 Turkington, +3.831s; 7 A Smith, +4.381s; 8 Goff, +4.772s; 9 Ingram, +7.105s; 10 J Smith, +7.152s; 11 Moffat, +11.762s; 12 Scott, +12.121s; 13 Cook, +12.531s; 14 Collard, +16.099s; 15 Welch, +19.046s; 16 Abbott, +20.590s; 17 Morgan, +20.808s; 18 Newsham,

+22.635s; 19 Palmer, +33.691s; 20 Lines, +35.612s; 21 Belcher, +41.301s; 22 Austin, +50.502s; 23 Bushell, +1m01.175s; 24 Gallagher, -2 laps; **R** Priaulx, 11 laps-engine; **NC** Martin, 11 laps; **R** Wilmot, 8 laps-engine; **R** Depper, 0 laps.

Winner's average speed 90.89mph.

Fastest lap Priaulx, 1m26.404s, 92.74mph.

GRID RACE 3

Decided by result of Race 2, with top six reversed.

CHAMPIONSHIP

1 Plato, 157; 2 Shedden, 154; 3 Neal, 149; 4 Jordan, 144; 5 Turkington, 124; 6 Morgan, 114; 7 Tordoff, 111; 8 Goff, 104; 9 A Smith, 93; 10 Collard, 81.



Monteiro broke Citroen stranglehold in race two

WTCC MOSCOW (RUS), JUNE 6-7 RD 5/12

46

Muller hits back to end Lopez's run

YVAN MULLER'S EFFORTS TO RECLAIM his World Touring Car Championship crown from Citroen team-mate Jose Maria Lopez during the opening four rounds of this season had fallen short, leaving the four-time champion 51 points down heading to Moscow Raceway.

But in Russia, he slashed that gap to 35 after halting Lopez's run of opening-race form, thus becoming the first driver other than the Argentinean to win the first race of a WTCC weekend since the series visited Beijing, eight months and eight meetings ago.

Lopez's chances of continuing his streak looked dicey from the start of the weekend, with Honda's Gabriele Tarquini topping the Friday test and first practice on Saturday, before Rob Huff and Lada – on home soil for

the Russian marque – set the pace in second practice.

The definitive order appeared wide open going into qualifying, but Citroen came good and Lopez looked on course for another pole position when he topped Q2. The single-lap shootout that followed was close-run between him and Muller, but it was the Frenchman who won out, by a mere 0.046 seconds.

Muller had taken the qualifying spoils in Hungary at the start of May but lost the lead to Lopez at the start. This time, he made the most of his pole, building a three-second gap over Lopez as he notched up his second successive win.

Lopez squandered an opportunity to outscore Muller in race two when he messed up the start. He jumped forward before the lights went out

and then stopped again, causing him to be passed by Muller and others.

Lopez fought his way back past his rival but it was all in vain due to the inevitable drivethrough penalty for his earlier foul. He finished down in 12th and missed out on points for the first time since the same race 364 days earlier, while Muller worked his way through to sixth.

World champion Lopez is still in a position to be philosophical.

"Normally, I'm quite hard on myself when I make mistakes, but on this occasion I think I just have to put it behind me," he said. "I've had the perfect season so far, and I still leave here as the leader."

Unable to make good on their practice pace, Tarquini and Huff had to make do with places on the second row for the first race. After the pair pursued the lead Citroens in the early laps, Tarquini dropped back, but managed to keep third.

Both Honda and Lada starred in race two. From the reversed-grid pole, Tiago Monteiro led from start to finish for his first win since 2013 and the factory Honda squad's first this year.

Behind him, it was an action-packed race as Huff made a second attempt at getting Lada onto the podium at home.

At the start of the race, the focus was on Nicky Catsburg. The Dutch



Huff took P2 in race two on 'home' soil

GT ace had been drafted into the third Vesta for this event at the expense of the championship's only Russian driver, Mikhail Kozlovskiy. After acclimatising well to front-wheel drive, Catsburg started second on the reversed grid, and although a beginner's standing start dropped him behind Norbert Michelisz, he was still on course for a podium.

That was until Huff swept past, after charging from seventh on the grid. The Briton went on to snatch second away from Michelisz before the end, while Catsburg held onto fourth – after contact with Tarquini sent the veteran into the barriers.

"The car was just fantastic," said Huff after scoring the Vesta's first podium. "I was able to push hard and in the middle of the races we were so quick."



Muller ended JML's 2015 race-one rout

FULL RESULTS, P44



FAN VILLAGE 2015

IN PARTNERSHIP WITH
WHITTLEBURY PARK
FEATURING THE
ABU DHABI FANZONE



The F1 Racing Fan Village returns

If you're going to see the 2015 British Grand Prix and need somewhere to stay, our Fan Village is the perfect place!

Where will you be staying?

The F1 Racing Fan Village is adjacent to the Silverstone circuit and is an easy ten-minute drive from the M1.

Free YasWI-FI on site

Stay connected with the latest news, or watch the highlights on your mobile device with our free wi-fi service, provided by title sponsors **Yas Marina Circuit**

YasTV

Giant Screen courtesy of **Yas Marina Circuit & #AbuDhabiGP** will keep you in touch with everything that's going on, including news updates, plus you can post your thoughts on the Twitterwall

YasSPA

Free treatments - nails, massage, facials & face painting. Private area to get ready with all the tools you need to curl/straighten your hair, apply your make up before joining us for the evenings entertainment

NEW FOR 2015

YasGAMES ZONE

Try new the new generation sim with Oculus Rift - drive around the **YAS Marina Circuit**. Play garden games like Giant connect4, Jenga, naughts & crosses, draughts & many more

NEW FOR 2015

YasCAFE

Grab your free hot drink and pastry on your way to the circuit from our Air Stream Cafe. We'll even give you an ice lolly to cool you down on your return (while stocks last)

NEW FOR 2015

Dinner & Rockaoke night

Join F1 Racing and David Brabham for a buffet dinner and star in your own version of a classic with the help of a rock band! Book now, tickets are selling fast Call **01327 850 027**

NEW FOR 2015

Beer tent

The beer tent is the social centre of the Fan Village, and will feature live music on both the Friday and Saturday evenings

Competitions

Chances to win great prizes throughout your stay, including race tickets, watches and champagne. One golden ticket winner will win flights, accommodation and tickets to the **#AbuDhabiGP**, courtesy of **Yas Marina Circuit**

Keep up to date

For the latest news, look us up on Facebook or follow us on Twitter **@F1R_FanVillage**

Share your memories with us on our Facebook page or on Twitter



Check out our video by scanning the QR Code with your phone ▶

www.f1racingfanvillage.com





ValetPRO's first phase of production is by profiling what we want from a product. Once our profile is set, we go to work and create a base formula. Various tests and experiments are conducted using a selection of additives, with these formulas tested on our own vehicles. The process continues until we achieve our desired results, fulfilling the brief and criteria first set, creating a product worthy to wear the ValetPRO label.

Profile

Black to the future - To spread as easily on tyres as it does on trims.
Holds on to a multitude of exterior surfaces from tyres to exterior trim
Revives faded plastics, lasting 2-3 months after application.
Leaves a grease free finish.
Resist detergents.
Repels water at a hydrophobic level.

I believe we've created a unique product in 'Black to the Future' and it's my personal favourite for reviving tyres, and a breeze to use on exterior trim with fast restoration and protection qualities.

WANT TO USE IS JUST PART OF THE FUN.



Beading Marvellous - Our ultimate quest was to create a paste wax that was easy to buff off after application, even if the wax was left on for an hour or applied in direct sunlight (as customers sometimes have to do). This was an extremely difficult request considering if most paste waxes are left on for too long they can be incredibly difficult to buff up, especially on hot summer days when most people tend to wax their cars. Maintaining durability was also essential, we needed 3 months protection for a daily driver.

Beading Marvellous was one of our challenging, yet favourite projects. In my experience, we have created the easiest car wax to buff off that leaves an incredible silky finish (to the touch) and high gloss shine you come to expect from carnauba wax. Beading Marvellous is the best wax we have made and one of our favorite products.



EVERYONE LOVES THAT FAST CAR SMELL.



NOW ANYTIME CAN BE GO-TIME.

K&N® high-flow air filters are designed to increase horsepower with up to 50% more airflow. And with five-minute installation, better performance doesn't get much easier. Order yours online today.

KNFILTERS.COM



SUPERIOR AIRFLOW. SUPERIOR PERFORMANCE.™



GOVERNMENT OF MALTA EXPRESSION OF INTEREST (EOI)



INVESTMENT OPPORTUNITY

The Privatisation Unit (PU) on behalf of the Parliamentary Secretary for Research, Innovation, Youth and Sport, is issuing an EOI regarding a Concession for the Design, Build and Operation of Motor Recreation & Education Park.

Interested parties are invited to communicate with the PU, at the email address shown below, expressing their interest in the EOI. Following this, the PU will forward a process letter to explain the procedure to be followed for the collection of the EOI document and submission of the Proposal.

The Chairman
Privatisation Unit
Ministry for the Economy, Investment and Small
Business

✉ privatisation.meib@gov.mt

🌐 www.privatisation.gov.mt

**ERC RALLY AZORES (P),
JUNE 4-6 RD 4/10**

Breen's mid-Atlantic drift is too hot

PEUGEOT DRIVER CRAIG BREEN TOOK his third consecutive ERC win to extend his lead of the series.

The Irishman's eventual margin of just over a minute belied how hard he had to fight for the victory. After the first stage of the final morning he was lying 0.5 seconds behind his key rival, Poland's Kajetan Kajetanowicz in a Ford Fiesta R5, who lies second in the standings.

Right from the start of the rally the pair were in a class of their own, rapidly pulling away from the top local expert in third: seven-time Azorean champion Ricardo Moura, also driving a Fiesta R5.

Both Breen and Kajetanowicz each led three times during the three-day event, but the turning point of the rally was SS13, Tronqueira. Right from the beginning of Saturday, Kajetanowicz believed he had chosen tyres that were too hard for the soft conditions and his conviction was proved correct on Tronqueira when he dropped a



**Breen stretched his
ERC points lead**

disastrous 16.3 seconds to Breen.

"It was completely my fault: the tyre choice was my call and I just didn't think the surface would be as soft as it was," said Kajetanowicz. A glimmer of hope remained for him on the following short superspecial when he took 3.9s back out from Breen in as many kilometres.

But Kajetanowicz knew he still needed a miracle during the final

three stages, so gambled on a soft tyre choice. Ultimately this only increased Breen's lead. "We came here needing a win and we really sweated to get it," said Breen at the finish. "You don't want to smell inside our car: it stinks in there!"

Peugeot UK protege Chris Ingram won the Junior section and also the Colin McRae Flat Out Trophy.

● Anthony Peacock

RESULTS

1 Craig Breen/Scott Martin (Peugeot 208 T16), 2h45m59.6s; 2 Kajetan Kajetanowicz/Jaroslav Baran (Ford Fiesta R5), +1m02.1s; 3 Ricardo Moura/Antonio Costa (Ford); 4 Bruno Magalhaes/Hugo Magalhaes (Peugeot); 5 Robert Consani/Maxime Vilmot (Citroen DS3 R5); 6 Jose Pedro Fontes/Miguel Ramalho (Citroen). **Points**
1 Breen, 78; 2 Kajetanowicz, 75; 3 Alexey Lukyanuk, 43; 4 Consani, 40; 5 Siim Plangi, 28; 6 Jaromir Tarabus, 26.

SUPER TC2000 RIO HONDO (RA), JUNE 7 RD 4/12

Renault man takes his turn

WORKS RENAULT FLUENCE DRIVER Christian Ledesma became the fourth different winner from the four rounds held this season.

Ledesma and Mariano Werner (Ford Focus) won the morning heats, and it was Ledesma who charged into the lead of the 28-car field at the start of the final, which this time would feature a mandatory pitstop for tyre changes.

Facundo Arduso disposed of Werner at the first corner and, while Werner gradually fell back, Arduso's Fiat was a serious threat for the win. Eventually he wrested the lead of the race, building an advantage of up to three seconds before a misfire spelled the end of his race. That allowed Ledesma, who left it until the penultimate lap to

take his pitstop, back in front.

Rafael Morgenstern ran sixth in his Toyota in the early stages, but he came through the order to claim second from the Fiat of Facundo Chapur, who leads the standings.

It wasn't a good race for reigning champion Nestor Girolami, who posted his first retirement in almost a year with his Peugeot.

● Tony Watson

RESULTS

1 Christian Ledesma (Renault Fluence), 21 laps in 37m41.371s; 2 Rafael Morgenstern (Toyota Corolla), +3.193s; 3 Facundo Chapur (Fiat Linea); 4 Matias Rossi (Toyota); 5 Jose Manuel Urcera (Fiat); 6 Lucas Benamo (Peugeot 408). **Points**
1 Chapur, 74; 2 Rossi, 70; 3 Agustin Canapino, 53; 4 Facundo Arduso, 49; 5 Nestor Girolami, 49; 6 Lucas Colombo Russell, 44.



**Isaakyan leads from
Vivacqua and Hughes**

FORMULA RENAULT ALPS SPA (B), JUNE 6-7 RD 4/7

Hughes gains on Aitken

THE INTRA-KOIRANEN TITLE BATTLE between Brits Jake Hughes and Jack Aitken ramped up a notch in Belgium, as Russian Matevos Isaakyan made ground on both.

Hughes had pole for the opening race, and had to fend off a challenge into Les Combes on the opening lap from Aitken and Isaakyan before establishing a breathing space at the front.

The Brummie was in front when the race was red-flagged and not restarted in the closing stages, while Isaakyan and Thiago Vivacqua both managed to defeat series leader Aitken.

JD Motorsport stole a march on the Koiranen boys in second qualifying, with Isaakyan taking pole and his Brazilian team-mate Vivacqua sharing the front row.

Isaakyan led all the way in this one, while Vivacqua managed to fend off the advances of Hughes for second, despite a late safety car – for a shunt between Stefan Riener, Danylo Pronenko and James Allen (no, not that one) – bunching the field up.

London-based Scottish-Korean Aitken was fourth, and his lead is now trimmed to seven points.

RESULTS

Race 1 1 Jake Hughes, 10 laps in 23m13.776s; 2 Matevos Isaakyan, +1.716s; 3 Thiago Vivacqua; 4 Jack Aitken; 5 Stefan Riener; 6 Danylo Pronenko. **Race 2 1 Isaakyan**, 11 laps in 29m02.393s; 2 Vivacqua, +3.471s; 3 Hughes; 4 Aitken; 5 Vasily Romanov; 6 Philip Hamprecht. **Points 1 Aitken, 149**; 2 Hughes, 142; 3 Isaakyan, 129; 4 Riener, 109; 5 Vivacqua, 101; 6 Romanov, 48.



**Ledesma: number
one at Rio Hondo**

NASCAR SPRINT CUP POCONO (USA), JUNE 7 RD 14/36

Truex booked his spot in the Chase

Truex: Not just part of the furniture



MARTIN TRUEX JR AND FURNITURE Row Racing always had fairytale potential. The small underdog team had got itself into the Chase by taking a punt on the disgraced Kurt Busch in 2013, but lost its star driver to Stewart-Haas. FRR then called on Truex, a race-winning driver who'd lost his Michael Waltrip Racing seat when sponsors pulled out over a scandal he hadn't been involved on.

But the first year of the Truex/Furniture Row combination brought little joy. Quiet on track with just two top-six finishes, it was overshadowed off-track by Truex's

partner Sherry Pollex's cancer battle.

The 2015 season started better: Truex has been rapid almost everywhere and second only to the rampant Kevin Harvick in 'regular points'. Yet despite leading the most laps at Kansas, Charlotte and Dover, the win always slipped away. At Pocono it didn't. Again Truex led the most laps but this time there was no late-race fade or strategic miscue. He simply outpaced Harvick when it mattered and won by a comfortable margin.

"Throughout my career I've kind of got used to disappointment and

learned to deal with those days where it didn't go your way even though you didn't do anything wrong," he said. "I wanted to win for this team because I knew how good they were and how much they deserved it. It would be easy the last three weeks to get down and to hang your head and to make excuses, but they didn't. They were excited. They knew we were going to get this win."

Behind Harvick, Jimmie Johnson overcame a puncture for third, and Joey Logano came from last on the grid (after a transmission change) to fourth, via a pitlane speeding penalty.

RESULTS

1 Martin Truex Jr (Chevrolet SS), 160 laps in 2h58m45s; 2 Kevin Harvick (Chevy), +1.346s; 3 Jimmie Johnson (Chevy); 4 Joey Logano (Ford Fusion); 5 Kurt Busch (Chevy); 6 Matt Kenseth (Toyota Camry); 7 Jamie McMurray (Chevy); 8 Kyle Larson (Chevy); 9 Kyle Busch (Toyota); 10 Denny Hamlin (Toyota). **Chase grid**
1 Johnson, 4 wins/481 points; 2 Harvick, 2/559; 3 Truex, 1/520; 4 Logano, 1/480; 5 Dale Earnhardt Jr, 1/465; 6 Brad Keselowski, 1/441; 7 Kenseth, 1/415; 8 Kurt Busch, 1/379; 9 Hamlin, 1/379; 10 Carl Edwards, 1/368; 11 McMurray, 0/427; 12 Kasey Kahne, 0/417; 13 Jeff Gordon, 0/411; 14 Paul Menard, 0/385; 15 Aric Almirola, 0/379; 16 Ryan Newman, 0/374.

JAPANESE FORMULA 3 FUJI (J), JUNE 6-7 RD 4/8

TOM'S pair share wins

TOM'S DRIVERS KENTA YAMASHITA and Nick Cassidy shared the wins for the Toyota-backed team, with the Kiwi retaining his points lead.

Honda protege Nirei Fukuzumi took pole position for the first race and led the first seven laps, but then Yamashita went past, swiftly followed by Cassidy.

While the TOM'S boys took their second one-two of 2015, Fukuzumi faded further to finish behind the Nissan-backed B-Max Dallara-Toyotas of Mitsunori Takaboshi and Daiki Sasaki (who was standing in for Le Mans-committed Lucas Ordenez for this round).

Cassidy made a bad start from pole for the second race, dropping to third. He moved ahead of Fukuzumi on the second lap before hunting down Takaboshi, who he passed under braking for Turn 1 with six laps remaining. Yamashita emerged from a scrap with Fukuzumi to hold



Yamashita dives past Fukuzumi

third from mid-distance.

British driver Struan Moore continued his campaign with a seventh and an eighth.

● Jiro Takahashi

RESULTS

Race 1 **1 Kenta Yamashita (Dallara-Toyota F312)**, 15 laps in 23m52.052s; 2 Nick Cassidy (D-Toyota F314), +1.545s; 3 Mitsunori Takaboshi (D-Toyota F315); 4 Daiki Sasaki (D-Toyota F312); 5 Nirei Fukuzumi (D-Mugen Honda F312); 6 Keishi Ishikawa (D-Toda F312). **Race 2**
1 Cassidy, 21 laps in 33m28.408s; 2 Takaboshi, +1.116s; 3 Yamashita; 4 Fukuzumi; 5 Sasaki; 6 Ishikawa. **Points** **1 Cassidy, 72**; 2 Yamashita, 63; 3 Takaboshi, 56; 4 Fukuzumi, 23; 5 Lucas Ordenez, 18; 6 Tsubasa Takahashi, 17.

GERMAN FORMULA 4 RED BULL RING (A), JUNE 6-7 RD 2/8

Eriksson scores a double

SWEDE JOEL ERIKSSON WON THE first two races of the weekend and has moved into the series lead.

The 17-year-old Motopark driver led all the way from pole in the first race, interrupted by two safety-car interventions, to beat Prema Powerteam duo Ralf Aron and Guan Yu Zhou.

Second time out, Eriksson won a big battle with Tim Zimmermann (Neuhauser Racing), with HTP Junior Marvin Dienst in third.

Joey Mawson had qualified on pole, but stalled at the start and finished well down the order. The race was red-flagged when Mick

Schumacher was punted into the barrier and broke his hand.

Mawson came good in a chaotic – twice red-flagged – reversed-grid race, the Australian dedicating his win to Van Amersfoort Racing team-mate Schumacher. The first stoppage came when Zhou rolled into the barriers after Mattia Drudi ran wide at Turn 1 and triggered a pile-up as he returned to the track.

● Rene de Boer

RESULTS

Race 1 **1 Joel Eriksson**, 18 laps in 30m52.720s; 2 Ralf Aron, +1.035s; 3 Guan Yu Zhou; 4 Michael Waldherr; 5 Tim Zimmermann; 6 Robert Shwartzman. **Race 2** **1 Eriksson**, 15 laps in 26m30.306s; 2 Zimmermann, +0.865s; 3 Marvin Dienst; 4 Mattia Drudi; 5 Waldherr; 6 Janneau Esmeijer. **Race 3** **1 Joey Mawson**, 7 laps in 27m36.752s; 2 Esmeijer, +0.777s; 3 David Beckmann; 4 Waldherr; 5 Jonathan Cecotto; 6 Kim Luis Schramm. **Points**
1 Eriksson, 74; 2 Dienst, 73; 3 Mawson, 64; 4 Aron, 63; 5 Waldherr, 48; 6 Drudi, 47.



Eriksson (right) battles Zhou

GT MASTERS RED BULL RING (A), JUNE 6-7 RD 2/8

Lambos on top in Austria

THE WEEKEND COULDN'T HAVE BEEN better for Lamborghini, with two wins for two models over the pair of races in Austria.

On Saturday, Tomas Enge and sometime Australian V8 Supercar driver David Russell came out on top with their Reiter-run Gallardo.

A quicker stop allowed Enge to emerge in front after the driver changes to give Hans Reiter's team its first GT Masters win in four years, while Russell was making his debut in the series on a circuit he had never driven before.

Dominic Jost had led up until the stops in his MRS GT Nissan, but the car would retire with electronic gremlins with Florian Scholze at the wheel. This allowed the Callaway Corvette of Andreas Wirth and Daniel Keilwitz up to second, with Sebastian Asch and Luca Ludwig third with the Zakspeed Mercedes.

Polewinning Schutz Porsche pairing Philipp Eng and Klaus Bachler had to make do with fifth following a slow puncture in front of their home crowd.

On Sunday it was the new



Enge/Russell Gallardo took race one honours

Huracan of the local Grasser Racing team – based just down the road from the Red Bull Ring – that took victory, driven by South African Adrian Zaugg and Austro-Italian Mirko Bortolotti.

Keilwitz and Wirth dominated until after the pitstops, but the Corvette turned into the pits due to vibrations on the rear axle with five laps remaining. With Bortolotti and Zaugg not registered for points, Enge and Russell took their second maximum score of the weekend after crossing the line in second place. Behind third-placed Eng/Bachler, Asch/Ludwig defended their points lead by finishing fourth from HTP Bentley duo Luca Stolz and Jeroen Bleekemolen, who drove

a strong race from 12th on the grid to finish fifth.

● Rene de Boer

RESULTS

Race 1 1 David Russell/Tomas Enge (Lamborghini Gallardo R-EX), 39 laps in 1h01m29.337s; 2 Andreas Wirth/Daniel Keilwitz (Chevrolet Corvette Z06.R), +0.944s; 3 Luca Ludwig/Sebastian Asch (Mercedes SLS AMG GT3); 4 Patrick Assenheimer/Diego Alessi (Chevy); 5 Philipp Eng/Klaus Bachler (Porsche 911 GT3-R); 6 Adrian Zaugg/Mirko Bortolotti (Lamborghini Huracan GT3). **Race 2** 1 Zaugg/Bortolotti, 38 laps in 1h00m10.334s; 2 Russell/Enge, +2.997s; 3 Eng/Bachler; 4 Ludwig/Asch; 5 Luca Stolz/Jeroen Bleekemolen (Bentley Continental GT3); 6 Florian Scholze/Dominic Jost (Nissan GT-R Nismo GT3). **Points** 1 Asch/Ludwig, 66; 2 Bachler, 65; 3 Enge, 51; 4 Russell, 50; 5 Bleekemolen/Stolz, 37; 6 Engelhart, 37.

FORMULA RENAULT NEC RED BULL RING (A), JUNE 6-7 RD 3/7

Deletraz fights back after Jorg wins twice

JOSEF KAUFMANN RACING ENJOYED A clean sweep of the three races, with Kevin Jorg taking two victories and Louis Deletraz the other.

Deletraz took pole for the opening race, but Jorg overtook his fellow Swiss Deletraz on the opening lap and led all the way thereafter for a one-two for the Kaufmann squad.

The battle for third was more intense, with Indian rookie Jehan Daruvala using all his skills to keep charging Fortec Motorsports team-mate Callan O'Keeffe at bay to finish third, his first podium result.

Jorg had pole for the second race, and led team-mate Deletraz in the

repeat of the opener. Adding to the deja-vu was another all-Fortec battle for third, with Daruvala and Briton Alex Gill this time as the main actors. This team it was Gill who came out on top for his first podium.

It was Deletraz's turn in the finale. From pole he won the race from Jorg, with Russian Nikita Mazepin completing a Kaufmann sweep of the podium with his best result yet.

Once again there was a Fortec fight, although this time it was for fourth, with O'Keeffe, narrowly heading Ferdinand Habsburg.

Irishman Charlie Eastwood took a best result of fifth in his AVF-run

car, while MGR Motorsport's Brit Colin Noble peaked with an eighth.

GP2 racer Nobuharu Matsushita did free practice to learn the circuit.

● Rene de Boer

RESULTS

Race 1 1 Kevin Jorg, 17 laps in 26m22.077s; 2 Louis Deletraz, +0.564s; 3 Jehan Daruvala; 4 Callan O'Keeffe; 5 Alex Gill; 6 Ferdinand Habsburg. **Race 2** 1 Jorg, 17 laps in 26m14.543s; 2 Deletraz, +1.748s; 3 Gill; 4 Daruvala; 5 Charlie Eastwood; 6 O'Keeffe. **Race 3** 1 Deletraz, 13 laps in 20m13.400s; 2 Jorg, +1.601s; 3 Nikita Mazepin; 4 O'Keeffe; 5 Habsburg; 6 Ukyo Sasahara. **Points** 1 Deletraz, 175; 2 Jorg, 129; 3 Sasahara, 124; 4 O'Keeffe, 101; 5 Gill, 90; 6 Daruvala, 78.



Joy for (l-r) Mazepin, Deletraz and Jorg



GLOBAL RALLYCROSS

Scott Speed was the gold medal winner at the X Games event in Austin in his Andretti Autosport Volkswagen Beetle, beating the Chip Ganassi-run Ford Fiesta of Steve Arpin and Sebastian Eriksson's OlsbergsMSE Fiesta. Speed managed to fight his way past Eriksson for his third victory in the event. Brian Deegan, Tanner Foust and Andreas Bakkerud were next.

SMP FORMULA 4

Three men shared the honours as the Koiranen-run series supported the WTCC at Moscow Raceway. Aleksanteri Huovinen won the opener after a terrific move on fellow Finn Niko Kari in the final laps. Kari avenged his defeat in the second race, this time taking the win from Huovinen. In the finale, Aleksey Korneev snatched honours for the home side with a great manoeuvre in the late stages on Huovinen, while Kari was also able to get past to claim second.

FRENCH GT

Two races were held on the series' away visit to Spa, with Arno Santamato, Eric Cayrolle and Stephane Lemeret triumphing in the opener in their Sport Garage Ferrari on the lmsa Porsche of Sebastien Dumez, Raymond Narac and Olivier Pernaut. The lmsa trio stepped up to win the second race, beating another Ferrari, the ASP car driven by Morgan Moullin Traffort, Philippe Giauque and Jean-Luc Beaubelique.

ASIAN CARRERA CUP

Ex-Formula Master champion Chris van der Drift moved into the series lead thanks to two wins at Fuji, the Kiwi defeating Austrian Martin Ragginger in both races. Craig Baird, the pre-weekend points leader, took a third and a seventh, with Ho-Pin Tung also grabbing a podium.

FMASTERS CHINA

Estonian Martin Rump scored two wins at the Shanghai International Circuit to take a narrow points lead over Australian Jake Parsons. Rump grabbed the lead from Parsons on the penultimate lap of the opener, with Daniel Woodroof also slipping past for second. Rump beat Nicholas Rowe in the second race, while Parsons bounced back from mechanical troubles in that one to win the third from Rump.

NASCAR TRUCKS

Reigning champion Matt Crafton took honours at Texas Motor Speedway in his ThorSport Toyota after a couple of tense late restarts against Daniel Suarez. Crafton got the better of the last, with two laps to go, to beat Suarez and extend his points lead to 25 over Tyler Reddick.

CAN

HULK



54

Force India F1 driver Nico Hulkenberg makes his Le Mans debut for Porsche this weekend. **EDD STRAW** explains why

Nico Hulkenberg never gives much away. Ask him how he came to be making his Le Mans 24 Hours debut for Porsche this weekend, making him the first driver since Sebastien Bourdais in 2009 to dovetail an assault on the twice-round-the-clock classic with a Formula 1 season, and it comes across as nothing more than a pleasant diversion.

“It was the middle of last year when the first contact happened,” he says. “Porsche was thinking about a third car and they needed drivers. So once the decision was made to do the third car, there was a big interest from both sides. First I needed permission from Force India, which I got, and then it was pretty straightforward.”

“I was always focused on F1 growing up; of course I knew about Le Mans and so the race has always been on my radar and I’ve watched it when possible. But over the past couple of years I’ve started to

BACKGROUND IMAGE: XPB IMAGES

CROSSOVER SUCCESSES

Surprisingly, relatively few drivers have won in F1 and at the Le Mans 24 Hours. Of the 95 drivers who have won world championship grands prix (this excludes the winners of the points-paying Indianapolis 500s of 1950-1960), only 16 have also won at Le Mans. The last was Michele Alboreto, 18 years ago.



Maurice Trintignant
Le Mans win 1954
F1 wins 2



Jose Froilan Gonzalez
Le Mans win 1954
F1 wins 2



Mike Hawthorn
Le Mans win 1955
F1 wins 3



Phil Hill
Le Mans wins 1958, '61'62
F1 wins 3

TIMELINE PICS: LAT

SMASH

LE MANS?

55

follow it more closely.”

It's well known that Hulkenberg's presence in the Porsche Le Mans line-up, and for the Spa 6 Hours World Endurance Championship round last month, was a consequence of him and his management pushing Porsche for it. Not that Porsche needed too much convincing, given the quality of Hulkenberg as a driver. And while the 27-year-old is a rarity in terms of earning well in F1's midfield, there's no doubt that he sees a full-time move into a manufacturer team as a viable option for his future, especially if he can't find paid employment in grand prix racing.

The car he's racing has something of a 'junior' feel to it, with the German, Nick Tandy and Earl

Bamber all having their first taste of LMP1 racing this year, so Hulkenberg was an obvious choice.

Hulkenberg's running so far has been inconclusive. During the rain-affected test day at Le Mans two weeks before the race it was difficult to make anything of his lap times. The same was true of his outing at Spa. There, Tandy put the car in the wall early on after a clash while lapping the GT Porsche of Kevin Estre. That, combined with a broken damper in the final third of the race, left the car down in sixth.

That made the car little more than a test hack for the Porsches battling up front, so Hulkenberg ended up double-stinting his tyres mid-race to allow the team to make a more informed

decision on strategy for the sister cars.

Comparisons with other Porsche-driver double stints were difficult, but his performance was at least decent.

In qualifying, he was two tenths slower than Tandy, although neither got the most out of the car, with Hulkenberg admitting that he missed the apex at the La Source hairpin by “a remarkable margin”. So judgements on his first endurance-racing foray will have to wait until this weekend.

“I think I did OK,” says Hulkenberg of his experience at Spa. “There is room for improvement and the learning curve with this car is not at an end. I'm still learning and getting better every time I get in. Dealing with the ▶



Lorenzo Bandini
Le Mans win 1963
F1 wins 1



Ludovico Scarfiotti
Le Mans wins 1963
F1 wins 1



Jochen Rindt
Le Mans win 1965
F1 wins 6



Bruce McLaren
Le Mans win 1966
F1 wins 4



Dan Gurney
Le Mans win 1967
F1 wins 4



Pedro Rodriguez
Le Mans win 1968
F1 wins 2

Maha msr 500 for day rate rental
08452267626
secure parking



Monster Tuning Ltd, Unit A6,
 Stafford Park 15, Telford, Shropshire TF3 3BB
 Email : info@monstertuning.co.uk
 Phone : **0845 226 7626**
 web : www.monstertuning.co.uk

www.classicbw.org

MG **OWNERS CLUB**

CLASSIC BRITISH WELCOME SAINT SATURNIN

On the road to the Le Mans 24 Hours

12 june 2015
9h00 - 17h00

A festival of 1000 classic and sports cars just 10 minutes from Le Mans, with more than 100 MG's on show.

Theme 2015 : MG
 Patron : Tom KRISTENSEN

FREE ENTRY AND PARKING

QUALITY MOTORSPORT LOOMS
FROM A PROVEN MOTORSPORT MANUFACTURER

- Looms manufactured to Tyco System 25 and IPC-620 standards
- Fully automated CNC and semi auto tooling
- ISO9000, ISO:14001 and OHSAS:18001 approved

Quality is key to our success - and yours!



scan for more info



Contact us now with your requirements.

UNIT 14 MOUNT PLEASANT INDUSTRIAL PARK,
 SOUTHAMPTON, SO14 0SP, ENGLAND
 TEL: **+44 23 8022 7636**
 EMAIL: sales@st-cross-electronics.co.uk

St. Cross Electronics
 Established 30 Years 1983 - 2013



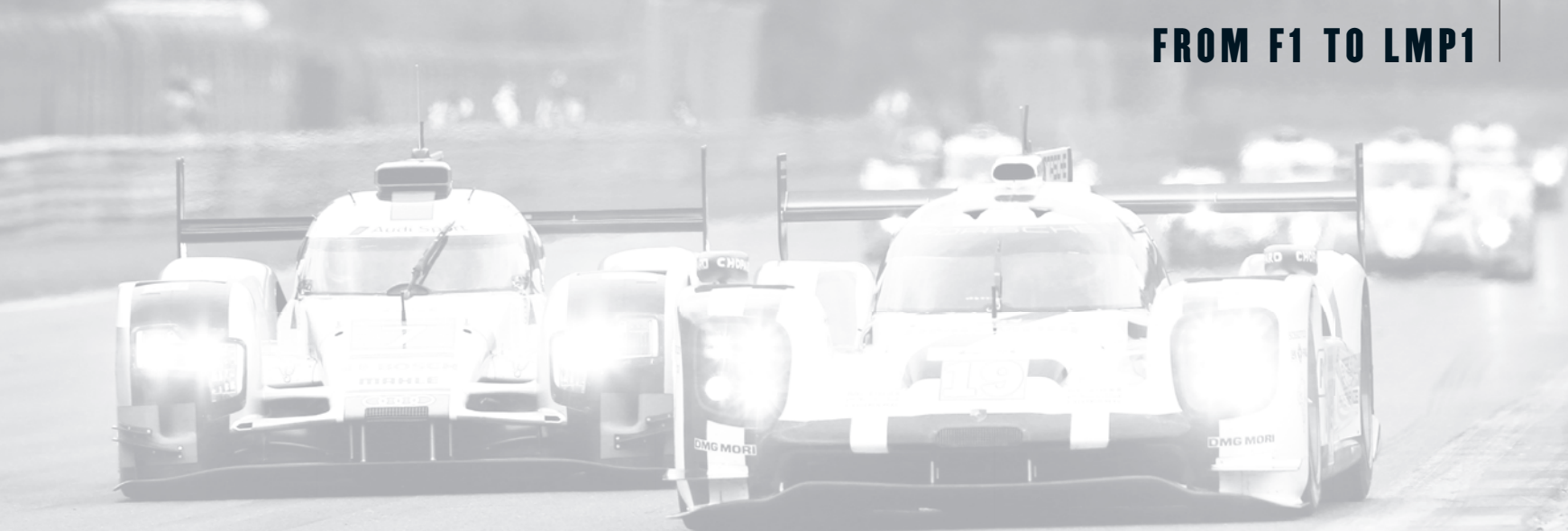

► traffic is exciting and I really enjoyed it, because it's an extra challenge learning how to read the guy in front and position myself.

"Spa was straightforward and the traffic wasn't as bad as I expected it to be. Normally you see big accidents there but there wasn't one, so that tells me the race was well-managed and driven by everyone. I didn't have any particularly bad moments."

Those weren't the only new challenges for Hulkenberg, who had to get used to sharing the cockpit with Bamber and Tandy. The existence of most racing drivers is purely selfish; get the cockpit exactly as you want, the set-up to your liking. Some single-seater converts struggle to get their heads around this challenge, but Hulkenberg insists not.

"That's not a challenge, it's just how it works," is his matter-of-fact response when asked about adapting to this. "You don't have any choice. The running time you get before the race is very little compared to F1 but I was very excited at Spa. In F1 you have a routine, but there everything was new and thrilling!"

"We are a very young, dynamic and quick trio. None of us have 24-hour-race experience in LMP1, although Nick is quite experienced in those races generally with GT cars. But without experience, you can still do a very good job and survive the race. I don't think experience is the one key element that you need. Experience will help in certain situations, though. I'm as well prepared as I can be. As I learn, it's like a work in progress in terms of mental set-up. I have to learn, adapt, adjust."

For the most part, the challenge of driving an LMP1 car isn't too different for Hulkenberg. It's slower than his Force India, so there's no challenge in adapting there. The Michelin rubber is very different to the Pirellis used in F1 although, as he discovered at Spa, when you are double-stinting you still have to manage them.

"At Spa, because I did the double stint I had to be a bit cautious, especially initially," he says. "So I probably didn't get the full experience. If I had



Hulkenberg takes over from Tandy in Spa 6 Hours

known we were changing after one stint, I could have pushed a lot more.

"But in testing at Paul Ricard, it was incredible as I was pushing for three hours flat-out in the car. It all depends how demanding the track is on tyres and what you are trying to achieve."

Provided the #19 Porsche 919 Hybrid lasts the distance, expect Hulkenberg to make a big impression. He is seriously fast, to the point where it beggars belief that he hasn't been picked up by one of the big F1 teams. The only real impediment is a combination of his relative weight (a hardly-massive 70kg, but still 11kg heavier than the lightest on the grand prix grid), and the natural conservatism of top F1 teams.

So what if he's never claimed a podium finish at the top level? He's achieved plenty of outstanding results in very middling machinery and even gained the admiration of rivals such as Fernando Alonso. His speed is guaranteed, and you should be able to rely on consistency. But where he could really stun is in tricky or mixed conditions. In F1, he is one of the best drivers on slick tyres on a damp track. His only real rival in that regard is Jenson Button.

But for a safety car, he and Button would have fought it out for victory in the 2012 Brazilian GP. Ultimately, Hulkenberg's race was ruined by a collision with Lewis Hamilton while battling for the lead in a midfield car. The advantage he and Button had built up was a result of staying out on slicks in the rain, maintaining tyre temperature and being happy with the car on the limit. If such conditions arise this weekend, watch out.

There's a good chance that this is the first step towards what may become a very credible full-time career option in the future for Hulkenberg. His focus remains on F1, but if he can't find a professional berth there, and if all goes well this weekend, he could emerge as Porsche's real ace in the longer term.

As for this weekend, while Hulkenberg is in Porsche's third-string car, it's certainly going to be in the mix or thereabouts. If the cards fall for its crew, victory is not out of the question. ❧

“WE ARE A VERY YOUNG, DYNAMIC AND QUICK TRIO. WE CAN DO A VERY GOOD JOB”

BACKGROUND IMAGE: XPB IMAGES



Jacky Ickx

Le Mans wins 1969,'75, '76,'77,'81,'82 F1 wins 8



Graham Hill

Le Mans win 1972 F1 wins 14

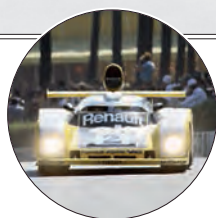

Didier Pironi

Le Mans win 1978 F1 wins 3



Jochen Mass

Le Mans win 1989 F1 wins 1



Johnny Herbert

Le Mans win 1991 F1 wins 3



Michele Alboreto

Le Mans win 1997 F1 wins 5

TIMELINE PICS: LAT

Formula One Grand Prix Weekends

Great Value
From only
£419
pp

4 & 5-day breaks available...

...by coach

Belgian (21 Aug 2015) **Monaco**
(19 May 2016) **Spanish** (5 May 2016)
Austrian (18 Jun 2015)

...by air††

Book your own flights and we'll do the rest. We even take care of your airport transfers.

Spanish (6 May 2016) **Italian**
(4 Sep 2015) **Monaco** (20 May 2016)

Plus... **24 Hour Le Mans and German Classic Motor Show 2016**

CALL OR CLICK TODAY!

Leger 0843 178 3736 
Holidays leger.f1-weekends.co.uk

All holidays are subject to availability. Terms and conditions apply. *Entry ticket and transfers to the Monaco Grand Prix qualifying session are extra. †Only available on coach holidays. ††Flights not included.

016292

Just look
what's included:

- ✓ Entry ticket to the qualifying session* and race day
- ✓ Transfers to the race circuit each day*
- ✓ 3 or 4 nights' hotel with breakfast
- ✓ Travel by executive coach from a choice of more than 500 regional joining points†
- ✓ Return Channel crossings†



**DEDICATED CAMPSITE
FOR MOTORSPORT
EVENTS AT SILVERSTONE**

HAMILTONFIELDS
silverstonecamping

- Campsite open for British Grand Prix, Moto GP and Renault World Series events
- Attractions within campsite include bar, catering and live entertainment
- Glamping, pre-erected tents and electrical hook ups available. Contact us for details



www.hamiltonfields.co.uk

Email bookings@hamiltonfields.co.uk



www.EMPIRE RV.co.uk

Living the high life

**BOOK YOUR LUXURY
ACCOMMODATION
FOR THIS YEAR'S
SILVERSTONE
GRAND PRIX**

**Our beautiful Winnebagos
can sleep up to 8 people**

To receive a 10% DISCOUNT, quote 'F1' when booking

- Empire RV, The Old Quarry, Wells Road, Emborough BA3 4SD
- Tel: +44 (0) 1761 300 489 ■ www.EmpireRV.co.uk ■ info@EmpireRV.co.uk

*Live like a
Formula One driver!*

WEB DIRECTORY

AWNINGS



aireshelta
No1 for Inflatable Structures.
With you from the Paddock to the Podium.
www.aireshelta.com

CAR BROKERAGE

RACING CARS FOR SALE
ALAN CORNOCK FCS
BUYING - SELLING - BROKERAGE
www.racingcarsforsale.co.uk
TEL: 01480 891212

ENGINES

Precision machining and engineering
Leading brand replacement & performance engine parts
www.gosnays.co.uk
Tel: 01708 748320



EXHAUSTS

Inconel & Stainless Steel Specialists
SIMPSON
Race Exhausts
Tel: 01753 532222
www.simpsonraceexhausts.com



GEARBOXES

Gearboxman.com
COMPETITION TRANSMISSION SERVICES
Gearboxes & Axles for Road, Race, Rally and more
Telephone: 01582 840008 Fax: 01582 840007

HELMET GRAPHICS

Visit: www.liquidcolourdesign.com
Studio: +44 028 93378525
Mob: +44 0770 9442894



HELMET GRAPHICS

Mike Fairholme Designs
Sole approved painter of Arai helmets.
Silver Birches, Corby Birkholme, Nr Grantham, Lincs NG33 4LE.
Tel: 01476 550630. Fax: 01476 550029.
email: fairholmedesigns@btconnect.com
www.fairholmedesigns.co.uk

MEMORABILIA

www.SpeedKing.cc
EXCLUSIVE MOTORSPORT MEMORABILIA
EST. 1996
We Buy Your Teamgear!

FINAL LAP
For Everything Formula One
www.finallap.net **WE BUY AND SELL**
+44 (0) 1245 287588 / 07771 920345

MOTOR RACING LEGAL ADVICE

Motor Sport Legal Advice
Tudor Alexander, LL.B Solicitor
tudor@fletcherday.co.uk
07887 713512

RACE PARTS

ARE DRY SUMP SYSTEMS
ARMSTRONG RACE ENGINEERING INC.
WWW.DRYSUMP.COM (916) 652-5282

RACE PRODUCTS

CARTEK
MOTORSPORT ELECTRONICS
info@cartekmotorsport.com
023 80 457747
www.CARTEKMOTORSPORT.COM



RACE PRODUCTS

JJC) race and rally
PASSIONATE ABOUT MOTORSPORT
www.jjcraceandrally.com

RACE RADIO

Pit to Car Autotel
Radio solutions **Digital Race Radio**
0044(0)1508 528837
www.raceradio.co.uk

RACEWEAR

AUTHORISED DISTRIBUTOR
OMP YBRACING
MOTORSPORT & PERFORMANCE
WWW.YBRACING.COM

demon tweeks
PROFESSIONAL MOTORSPORT EQUIPMENT
www.demon-tweeks.co.uk

RACING

MANUFACTURERS OF SPORTS PROTOTYPE RACING CARS
NEW & SECOND HAND MCR'S FOR SALE
ARRIVE & DRIVE PACKAGES
MCR RACE CARS



TRAILERS

BRIAN JAMES TRAILERS
» Connected to you
www.brianjames.co.uk

PRG TRAILERS
www.prgtrailers.co.uk
Phone no: +44 (0) 1270 812402

WORKSHOP EQUIPMENT

Image® Manufacturers of bespoke split rim alloy wheels
www.imagewheels.co.uk
IMAGE WHEELS INTERNATIONAL LTD.



TO ADVERTISE IN THE WEB DIRECTORY
PLEASE CALL 020 8267 5271
OR EMAIL: autosportads@haymarket.com

2008 WILLIAMS FW30

WILLIAMS

HERITAGE

£125,000 GBP + VAT if applicable

Direct from the Williams Grand Prix Collection, for the very first time on the open market, we are delighted to offer for sale the Ex-Nico Rosberg, 3rd place 2008 Australian GP Williams-Toyota FW30.

FW30A Chassis no. 03 is a highly significant car in the glittering history of the Williams Formula 1 team. Offered with impeccable provenance, having been driven at 6 Grands Prix in the 2008 F1™ World Championship by Nico Rosberg, most importantly to his first ever podium finish.

Meticulously prepared and presented in a non-running format, the car is complete with a Williams Heritage certificate of authenticity, a file of documentation including a representative selection of original engineering records and period photographs.



CARS
INTERNATIONAL
SERVICE

+44 (0) 1488 71029
WWW.CARSINTERNATIONAL.COM
WILLIAMSHERITAGE@CARSINTERNATIONAL.COM

CARS INTERNATIONAL

Operated by Cars International Service, Official Williams Heritage Agent



Mosler GT. Winner
GT Cup, GTO Class
Championship

BRITAIN'S FIRST ONLINE MOTORSPORT ENGINEERING DEGREE

Learn Online and On-track with one of our Race Teams

College/School leavers – earn while you learn & gain practical motorsport experience

Mature Students – A second chance for a Motorsport Career, study flexibly alongside work & family

Foundation Degree (FdSc) Motorsport Engineering

BSc (Hons) Motorsport Engineering



Awarded by Staffordshire University (subject to validation). The National Motorsport Academy, in partnership with Staffordshire University, is pleased to launch Britain's first online Motorsport Engineering degrees. In this competitive, global industry, Motorsport Engineers must have the broad range of skills demanded by the top teams. Working closely with the industry, we have designed our courses specifically to meet their requirements. Not only will our graduates be qualified Motorsport Engineers with practical experience, they will also be innovative, resourceful and commercially-focused. Making them highly sought after graduates.

Why study with us?

- Low Tuition Fees £5,500 per year/level
- Entry from 100 points
- Mature students welcome
- EARN while you LEARN
- Choose your own start date
- Your own personal tutor
- Unlimited tutor support, 5 days a week,
- Stimulating, interactive, course content
- Online forum to meet other students
- Student loans available
- Free Autocad & industry software, NUS card
- Guaranteed work experience placement

How to apply

Please register on our website today at
<http://motorsport.nda.ac.uk/how-to-apply>

What you will study

- Mathematics for Motorsport
- Race Car Design & Preparation
- R & D Simulation and Analysis
- Fundamentals of Motorsport Technology
- Fluid Mechanics & Thermodynamics
- Engine Design, Development & Simulation
- Vehicle Dynamics, Physics & Data Acquisition
- Work Experience & Research Study
- Advanced Engine Development
- Aerodynamics
- Hybrid & Electric Vehicle
- Final Project



New for 2015 Lotus GTE (Le Mans). Over 30 races planned.

MARKETPLACE

COMPETITION DIFFERENTIALS



WIN YOUR DREAM CAR
FREE £5 WHEN YOU SIGN UP
GUARANTEED WINNER EVERY WEEK

ENTER NOW AT **BOTB.COM**



BOTB.COM
WIN YOUR DREAM CAR

THIS WEEK'S WINNER

GRAHAM WILLIAMS
PORSCHE MACAN S

PREVIOUS WINNER

MOHAMMED KHAN
RANGE ROVER SPORT
+ £10K CASH

Tel: +44 (0)20 7371 8866
Email: info@botb.com

MARKETPLACE

PARTS



USE PROTECTION ADD STYLE

RIMBLADES
Buy Online
www.rimblades.com
£29.99 a set. Available in 10 colours
A GREAT BRITISH INVENTION

FLOORING

Kiwi Tiles
Interlocking Plastic Floor Tiles, as used by leading race teams throughout Europe.

- Easy installation & removal
- Many colours
- Lightweight
- Strong and durable
- Compact & easy to store
- Top quality
- Value for money

Stock Colours:
Red, Blue, Green, Yellow, Silver, Orange, Grey, Black, White, Dayglo Red

Ralt Engineering
Tel: 01865 883354 Fax: 01865 883789
Email: enquiries@kiwitiles.com
www.kiwitiles.com

MEMORABILIA

F1 COLLECTORS.COM

#1 FOR F1 MEMORABILIA & AUTOGRAPHS
We buy and sell F1 items
AYRTON SENNA specialists
Call CHRIS GRINT
01763 274448
email:- sales@f1collectors.com

TYRES

FOR ALL YOUR
AVON TYRES
MOTORSPORT
RACING TYRES
Inc. ACB 10 Formula Ford
Contact

BMTR LTD
Tel: 0121 331 1122
Fax: 0121 331 1144
email: sales@bmtr.co.uk
see our new website at www.bmtr.co.uk

AUTOSPORT

IF YOU'D LIKE TO
ADVERTISE YOUR
PRODUCTS AND
SERVICES PLEASE
CALL:
020 8267 5271

MARKETPLACE

RACE PRODUCTS

Elite Carbon Fibre

Carbon fibre race car component manufacturer

EliteCarbonFibre Ltd.
Units 20-22 Norwich Road Ind. Est.
Watton, Thetford, Norfolk IP25 6DR

Contact – Dave Greenwood 07809390316
Email – davecarbonelite@googlemail.com
Website – elitecarbonfibre.co.uk



Carbon Composite Wings, Bodywork & Repairs

demon tweeks PROFESSIONAL MOTORSPORT EQUIPMENT

• EXPERT ADVICE • MASSIVE STOCK • RAPID DELIVERY •

monit rally TERRA TRIP **BRANTZ PELTOR** Rallymeters

0844 375 2196
www.demon-tweeks.co.uk

LOW CALL RATE CALLS MAY BE RECORDED FOR TRAINING PURPOSES

London Motorsport Showroom

www.msar.co.uk

Order Hotline: 020 8655 7877

msar UK agent for **SCHROTH** RACING

Visit Us At Our New Larger Showroom

ti **WALBRO**

UK Distributor / Warehouse

Tel: +44 (0)1784 493 555
Fax: +44 (0)1784 493 222
Email: sales@glencoeltd.co.uk

Made in the USA

"Fuel Pumps for the Professionals":-
Original Equipment
Formula One
Race Teams
Rally Teams
Military

FAST ROAD
'IN TANK PUMP' UPGRADES
From £56.08
Pump kits..... £60.40

From £94.10
FAST ROAD
'OUT OF TANK' (3 BAR) REPLACEMENT PUMPS

400 450 LITRES/HR
EXTREME FUEL
For **EXTREME POWER**

190 255 LITRES/HR
MOTORSPORT
'IN TANK PUMP'
350 BHP From £65.80
500 BHP From £74.64
Kit prices From £75.90

325 LITRES/HR
MOTORSPORT
'OUT OF TANK'
325 LTR / HR
5 BAR FUEL PUMP
(180 LTR / HR @ 3 BAR)
From £99.50

MOTORSPORT 400 LTR/HR
Upto 600 BHP
Pt.No. GST400 (PUMP ONLY)
GST400K (PUMP KIT)
From £92.40

MOTORSPORT 450 LTR/HR
Upto 750 BHP
Pt.No. GST450 (PUMP ONLY)
GST450K (PUMP KIT)
From £112.00

Prices exclude VAT @ 20%

www.glencoeltd.co.uk

BELL & COLVILL[®]
HORSLEY - LIMITED



EXIGE



**ELISE
CUP**

Visit us at **Goodwood Festival Of Speed**
for **Bell & Colvill**
Exige & Elise Cup Exclusive Offer*

* Deals closed during FOS dates 25th - 28th June 2015
Several units available for immediate delivery



www.bellandcolvill.co.uk

enquiries@bellandcolvill.com

01483 286470 • Epsom Road, West Horsley KT24 6DG

Fuel Consumption (mpg [l/100 km]) Urban 19.5 - 28.5 (14.5 - 9.9)

Extra Urban 37.2-46.3 (7.6-6.1) Combined 28.0-37.7 (9.6-7.5) CO2 emissions 175-235 g/km



MARKETPLACE

RACE PRODUCTS



MARDI GRAS MOTORSPORT

Saloon Car Preparation

Unit 45, Silverstone Circuit
Towcester
Northampton NN12 8GZ

tel: 01327 858006 fax: 01327 858800
email: info@mardigras.co.uk
web: www.performanceclutch.co.uk

Distributors and agents for:



FOR SALE



DAF LF 55-180. 13t. Double sleeper cab, A/C, Cruise Control, Electric windows, Sunroof, 1500KG Tail lift, Big Inverter, Battery Guard, Auxillary compressed air supply in body, 29ft body, 4m in height so ok for Europe, LEZ compliant, long MOT and TAX, work bench and Vice, various racking and storage full awning and flooring included, good tyres all round, lots of floor lashing rings, side entrance shutter and steps, Full body kit and skirts.

POA

Call LEE on 07802496988

SPIRES OF OXFORD

SUPPLIERS OF LUXURY HOSPITALITY MOTORHOMES
ON EVENT COMMUNICATION & MEDIA CENTERS
PROMOTIONAL ROADSHOWS

INTERNATIONAL RACE CHAMPIONSHIP HOSPITALITY UNITS
EXCLUSIVE CORPORATE HOSPITALITY & TEAM CATERING
LOGISTICS & SECURE STORAGE

As specialists in the field of International motorsport, with vast experience in all levels of sports hospitality, promotional roadshows & corporate events, we can supply for hire or sale an exclusive purpose built, fully self contained event facility, ideal for all on circuit hospitality, championship/media centers, marketing, merchandising conferences product launches & roadshows, at any sporting event world-wide. Units vary in specification, and can include luxury lounges, office facilities, Commercial Kitchens, showers and full awning size options.

F1 SPEC MOTORHOMES & RV'S WITH AWNINGS

GENERAL SERVICES



- International race centers, VIP hospitality & team catering specialists
- Hospitality & shared team catering service at BES, Le Mans, WEC & ELMS
- Exclusive hospitality packages at all major events including, F1, WEC Touring Cars & Le Mans
- Sponsor/partner co-ordination, travel, accomodation, ticketing & VIP transfers to circuit
- Logistics on track marketing, merchandising, product sampling plus event support
- Management, logistics & operation of clients own units also underatken
- Comprehensive world-wide insurance



Exclusive VIP Hospitality



Race & Test Team Motorhomes



Shared Team Catering

For up to date information on our services, units and events visit www.spiresofoxford.co.uk
TEL:+44 (0)1865 875539 MOBILE: +44 (0)7836 767619 EMAIL: info@spiresofoxford.co.uk

Follow us on TWITTER: @spiresofoxford

BRIAN JAMES TRAILERS

»» Connected to you



www.brianjames.co.uk

Endurance and passion for excellence

Covering long distances, travelling through many years our trailers have served at every race or rally, up and down the country.

The latest Race Transporter models are testimony to the technology and designs our dedicated engineers have developed.

Photographed (above), Race Transporter 4 with optional style B1 alloy wheels.

Race Transporter range start from £ 6,750 (excl. VAT).

To find your nearest dealer visit:
www.brianjames.co.uk/dealer



CAR TRANSPORTER

T +44 (0)1327 308 833

For more information and details on the Brian James Trailers range, please contact our head office.

TRAILERS & TRANSPORTERS



www.**WOODFORDTRAILERS**.com

HIGH QUALITY TRAILERS FOR CLUB, PRIVATE AND PRO MOTORSPORTS



Email: sales@woodfordtrailers.com

CALL US NOW **01327 263 384**

TRAILERS & TRANSPORTERS

PRG TRAILERS

Finest Built British Trailers.



PRG Trailers | Cheshire | UK | Tel: +44 (0) 1270812402
Web: www.prgtrailers.co.uk | Email: info@prgtrailers.co.uk

Trailer with Motor home facilities....

This is a two year old immaculate fast towing very stable trailer which has full Motorhome facilities with sleeping for 3/4, separate shower toilet, kitchen with sink and three ring LPG burner, fridge, colour TV and Microwave, awning, mains hook up or LPG, storage for bedding, helmets etc etc, tanks for fresh water and grey water.....currently used for carrying a Morgan car...It is as new and can be viewed in Reading Berkshire...

£25,995.00 o.n.o (cost over £30,000.00)

Call Sam 07781 100630 or
further info SGSP@ME.COM



WINNEBAGO MINNIE FOR SALE



2003, LOW MILEAGE 32,000, EXTREMELY WELL EQUIPPED AND LAID OUT SIX BERTH, WITH SLIDE OUT, EXCELLENT CONDITION, UK 240V AC CONVERTED, RUNS ON LPG OR PETROL, GENERATOR, OVEN, FRIDGE FREEZER, MICROWAVE, AIRCON AND HEATING, WELL SERVICED REGULARLY, ROOF BOX STORAGE, GREAT LOCKER SPACE STORAGE, LED TV, RADIO/CD INSIDE AND OUT, AWNING, EXTERNAL SHOWER V10 6.8LITRE, TOW BAR, REVERSING CAMERA

Price **£26,750**

Contact Paul on **07812026628**

MOTORSPORT JOBS

AUTOSPORT

Want to advertise a motorsport job?

If you are recruiting in motorsport and wish to advertise with Autosport in print and online please contact Jonathan.Whitehead@haymarket.com by email or call 020 8267 5908.

For all current vacancies advertised please visit our website www.autosport.com



Due to new project activity and business expansion, we are looking for people to fill the following roles:

- Operations Manager
- Development Engineer
- Senior Engine Builder
- Engine Builder
- Trainee Engine Builder
- Experienced Dyno Operator / Test Technician
- Fabricator / Machinist
- Trainee Test Technician

Please apply in writing with a full CV to the following address:
Mathwall Limited, Old Portsmouth Road, Thursley, Surrey, GU8 6NJ
Or via email: info@mathwall.co.uk
Closing date for applications is **Friday 26th June 2015**
www.mathwall.co.uk

VACANCY

PA / Office Administrator



An opening for a dynamic and motivated team member in the role of a full time office based PA / Office administrator. The successful candidate will be adept at handling administrative and executive support tasks such as: organising and prioritising diary and travel arrangements; preparing documents; tracking finances and handling communications. In addition the candidate will be required to coordinate travel for two of the groups racing teams inclusive of flights, hotels, hire cars and visas. The position will also encompass general office tasks association with typical receptionist duties.

Financial Administrator

An opportunity to build your own future in a growing role. This position requires a candidate capable of managing a wide range of financial tasks across multiple business activities including: managing a cloud based accountancy package; budgetary reporting and management accounts; domestic and international invoice payments; reconciliation of company credit cards accounts; PAYE and VAT submissions.

Please send your covering letter, cv and expected remuneration to info@craftbamboo.com



From the moment Red Bull Racing first turned a wheel in Formula One it was always obvious that the ultimate goal of championship victories would only be achieved by a team that invested in F1's most crucial assets: people and experience. The team's Formula One adventure began in 2005. Today, a number of years on into the project and with four consecutive World Championships in the locker, that is still the philosophy propelling the team forward.

We are currently looking to recruit the following positions:

HR02061502 – SIMULATION & ANALYSIS ENGINEER

HR02061503 – VEHICLE DYNAMICS SIMULATION AND ANALYSIS ENGINEER

HR02061504 – TYRE SIMULATION AND ANALYSIS ENGINEER

As well as being part of our multi-Championship winning team, we reward our employees with a significant benefits package including Championship Bonus, Life Insurance, Private Medical Cover and a Pension Scheme.

For further information and details of how to apply please visit:
www.infiniti-redbullracing.com.

CLOSING DATE FOR APPLICATIONS: SUNDAY 21ST JUNE 2015
No Agencies please.



WE ARE CURRENTLY LOOKING TO RECRUIT THE FOLLOWING POSITION WITHIN RED BULL TECHNOLOGY:

HR02061501 STORES PERSON – DISTRIBUTION

We are looking for an experienced Stores Person to assist in the daily duties of one of our busy Stores departments. Ideally you will have current or very recent experience of working in a motor racing, aerospace or precision engineering stores environment and will be able to demonstrate your ability to work under pressure and to tight deadlines. Another desirable feature will be your ability to be flexible in regard to working a variety of shift patterns on either day or night shifts as required to do so. At Red Bull Technology we make extensive use of computer based stock management software, and therefore for this role computer literacy is an absolute necessity.

To be the successful candidate for this role you will need to thrive in a high pressure environment and be able to demonstrate the ability to work well under the minimum of direct supervision so self-motivation and high levels of attention to detail are key attributes to this role.

As well as being part of our multi championship winning team, we reward our employees with a significant benefits package including Championship Bonus, Life Insurance, Private Medical Cover and a Pension Scheme.

For further information and details of how to apply please visit:
www.infiniti-redbullracing.com

CLOSING DATE FOR APPLICATIONS – FRIDAY 19 JUNE 2015

PLEASE NOTE: No Agencies please.



Sunoco challenge latest

The Sunoco Challenges are well underway now! Last month we saw the Sunoco Whelen Challenge leading gap narrow between British GT3's Alexander Sims and Radical Enduro's Scott Malvern. But when Malvern took to the wheel in Radical Enduro last weekend he didn't get the results he hoped for, and has dropped in the standings from 2nd to 8th, a severe blow for his Daytona dream. There is still time for him to 'chase' his way back, but for the moment Sims can enjoy his 11 point lead and British GT3 can celebrate their 'domination' with 4 drivers in the top 5 standings!

In the Sunoco 200 Challenge Radical Sprint's McClughan still leads the standings ahead of MINI Challenge's Neil Newstead and Rob Smith. British GT3's Ross Gunn also moved into the top 5 after his efforts at Silverstone, but what results will the rest of the season bring?



www.sunocochallenge.com

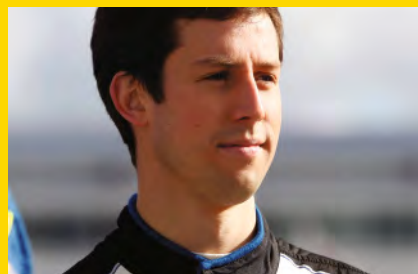

1	A Sims	British GT3	92.13
2	M Attard	British GT3	81.13
3	T Woodward	Radical Enduro	80.00
4	J Adam	British GT3	79.75
5	R Butcher/L Griffin	British GT3	78.38



www.sunocochallenge.com



1	P McClughan	Radical Sprint	100.00
2	N Newstead	MINI Challenge (JCW)	99.33
3	R Smith	MINI Challenge (Gen 3)	96.67
4	R Gunn	British GT4	89.38
5	B Dimmack	Radical Sprint	85.56

Points correct as of 08.06.15



Next eligible races

Sunoco Whelen Challenge

Radical Enduro 20-21/6
Radical Euro Masters 4-5/7
Radical Enduro & British GT 10-11/7

Sunoco 200 Challenge

MINI Challenge & GT Cup 13-14/6
Radical Sprint & Britcar 20-21/6
MINI Challenge & F3 Cup 27-28/6

See our website www.sunocochallenge.com for more information



In partnership with



Anglo American Oil Company

+44 (0)1929 551557 (tel) +44 (0)1929 551567 (fax) info@aaoil.co.uk www.aaoil.co.uk

CLUB AUTOSPORT

NATIONAL RACING • HISTORICS • RALLYCROSS • HILLCLIMB • TRACK TESTS



Winfield scholarship revived

Famed French-based racing school returns with FIA F4 drive on offer

THE NAME OF THE FAMED Winfield Racing School has been revived to unearth a future star who will get a free drive in FIA Formula 4 next season.

Based at the same Paul Ricard circuit where Alain Prost launched his career with a Winfield Volant Elf scholarship win in 1975, the new Winfield management is seeking an international field of up to 30 drivers to fight it out over a three-round, nine-race, centrally run mini-series next January.

The contest, known as the Winfield Winter Selection, offers 12 days comprising approximately 2500 miles of running over three track configurations of the Ricard circuit. The winner will be given a drive with top squad Prema Powerteam for 2016, with 10 race weekends, most likely majoring

on the German or Italian F4 championships.

While the old Winfield Racing School was most famously run by Jersey-raised Brits Mike and Richard Knight, together with business partner Simon de Lautour and top constructor Tico Martini, the new Winfield project is overseen by Lotus F1 marketing duo Fred Garcia and Anne-Charlotte Remy, together with Gravity Sport Management chief Gwenaél Lagrue, who has overseen the careers of Romain Grosjean, Marco Wittmann, Esteban Ocon and Richie Stanaway among others.

Garcia said: "As a Frenchman and motorsport enthusiast, I have a very personal and emotional connection to Winfield. It was such an iconic racing school throughout my childhood and when I got my driving

licence I took part in the Winfield scholarship programme myself, like so many young hopefuls."

What became the Winfield Racing School initially operated at Magny-Cours as a French branch of the Jim Russell school in the early 1960s before the change of title, in deference to the Knights' mother's maiden name. The first Volant winners – initially backed by Shell – won Formula 3 cars – before the prize became a funded season in Formula Renault in the late '60s.

In the early 1970s Elf took over the backing of the Volant awards, with two winners each year – at Magny-Cours and Paul Ricard – before both schools closed in the late 1990s in the wake of the arrival of Formula Campus, now known as the French F4 (non-FIA-spec) Championship.

TEN FAMOUS WINFIELD SCHOLARSHIP WINNERS...

Jean-Pierre Jaussaud, Francois Cevert, Rene Arnoux, Patrick Tambay, Didier Pironi, Alain Prost, Olivier Grouillard, Eric Bernard, Erik Comas and Olivier Panis

...AND SIX WHO MISSED OUT

Johnny Servoz-Gavin, Patrick Depailler, Jacques Laffite, Jean-Pierre Jarier, Damon Hill and Jason Plato



MARCUS SIMMONS
DEPUTY EDITOR

marcus.simmons@haymarket.com
@marcussimmons54



ONE OF THE MOST ENJOYABLE

features I ever wrote for AUTOSPORT was a retro piece on the Winfield Racing School, where I downloaded first-hand anecdotes on some of my childhood heroes from Knight brothers Mike and Richard (very capable pedallers themselves) on a crisp January morning seven years ago.

As a kid who attended Thruxton F2 races in the 1970s, and who loved the early Ligier F1 cars, this production line of talent was one I'd always wanted to investigate further. Hearing tales of young Prost, Cevert, Jarier, Laffite etc, the morning flew by.

As such, the Knights, together with Simon de Lautour (brother of actress Frances de la Tour, aka Miss Jones from *Rising Damp!*) and Tico Martini are probably among the most important figures in the history of French motorsport. Martini's single-seaters – which raced from Formula Renault, through F3 to F2 and (briefly) to F1 – even initially carried 'MW' (Martini Winfield) designation, before this changed to 'MK' (Martini Knight).

While the old Winfield school awarded Volant winners with French Formula Renault seasons, the new Winfield Winter Selection moves with the times in zeroing in on FIA Formula 4, and with Prema Powerteam the victor will have one of the world's leading junior teams behind them.

There is real racing passion behind this new identity too. I don't know Fred Garcia or Anne-Charlotte Remy personally, but Gwen Lagrue has a strong understanding of what goes into a young driver's career in the modern age, with reigning European Formula 3 champion Esteban Ocon as the most recent testament to that.





Kox will drive 650S with Nico Pronk

GT Cup

Kox back in a McLaren at Silverstone

SPORTSCAR STALWART PETER

Kox will next weekend race a McLaren at Silverstone for the first time since his FIA GT Championship victory for the marque at the wheel of a long-tail F1 GTR in 1997.

The 51-year-old Dutchman will drive a McLaren 650S GT3 entered under the Kox Racing banner in the fourth round of the GT Cup. Kox will race

together with owner and McLaren collector Nico Pronk, with whom he is contesting a mixed programme of events in 2015.

They will share the car in the 50-minute pitstop and then Pronk, who previously raced with Kox in a Lamborghini Gallardo in 2012-14, will compete alone in the two 25-minute races for the amateur driver in

each pairing.

Kox said: "I've been working with Nico to bring his performance up, and I think the GT Cup might be the right level for him. And, of course, the Silverstone Grand Prix circuit is a great track that everyone wants to race on.

"There is nothing set in stone at the moment, but we could do more GT Cup races if Nico likes the format."

Kox triumphed in the Silverstone FIA GT round in May 1997 with Roberto Ravaglia. Their factory Schnitzer McLaren-BMW F1 GTR crossed the line second behind the Mercedes-Benz CLK-GTR driven by Bernd Schneider and Alex Wurz, but were awarded victory on countback after the race was red-flagged following a torrential downpour and a series of shunts.

Renault UK Clio Cup

Sutton calls for crackdown on Clio driving standards

RENAULT UK CLIO CUP RACER

Ashley Sutton has called for a crackdown on driving standards in the championship after a chaotic final race at Oulton Park last weekend.

SV Racing driver Ant Whorton-Eales was stripped of his race-two win after an overly aggressive move on Ash Hand, but Sutton called for officials to go further.

"I think things need to be looked at," said the 21-year-old. "At the moment everyone knows they can get away with it. Someone needs to put their foot down otherwise it's going to get dangerous. In race two I was forced out wide into a pack of lunatics."

Former champion and long-time Clio Cup racer Paul Rivett countered: "There have always been issues with driving

standards in single-make championships. "Race two was a demolition derby but that happens from time to time.

"The clerk of the course has imposed penalties, and it takes a lot for them to take a win away from a driver. I don't think there are major issues."



Ginetta Junior

Double victor Caroline not banned after appeal victory

GINETTA JUNIOR FRONTRUNNER

Jamie Caroline avoided a licence ban after successfully winning an appeal for an incident in the second race at Oulton Park last weekend.

HHC Motorsport driver Caroline was protested by Dan Zelos' JHR team after the two made contact at the start of race two on Sunday.

Caroline, who won both Oulton races, was originally handed two licence penalty points for the incident but the stewards later overturned the



decision, stopping him from reaching the 12-point ban threshold.

The Pirtek young driver already had 10 penalty points on his licence prior to the meeting. Four of those were accrued at Oulton last year and as points are repealed after 12 months, he is now back down to six penalty points.

"I'm really pleased because it makes a big difference," admitted HHC commercial director Charlie Kemp. "He fully deserved the double."

Comprehensive motorsport insurance products to keep you on track;

- 🚗 Worldwide On Track
- 🚗 Personal Accident
- 🚗 Storage and transit
- 🚗 Track day
- 🚗 Liability
- 🚗 Commercial



Please complete an online quote request form at – www.ryanmi.com

Email – info@ryanmi.com Tel – +44 (0) 1799 524202

Ryan Motorsport Insurance Limited is an appointed representative (557405) of Independent Broking Solutions Limited who are authorised and regulated by the Financial Services Authority, registration number 312026

Porsche Supercup

Cammish and Webster set for British GP support race

PORSCHE CARRERA CUP GB frontrunners Dan Cammish and Josh Webster will compete in the British Grand Prix-supporting Porsche Supercup race.

Cammish, who leads the Carrera Cup points standings, will make his Supercup debut at a track he knows well.

"It will be the biggest race of my career so far," said Cammish. "I know the circuit

probably as well as anyone so there is no reason why we can't get a good result."

Both drivers will compete with their respective Carrera Cup GB teams, with Team Parker Racing driver Webster competing in the event for a second year in a row, and both played down the size of the step up to Supercup level, praising the British series' quality.

"Obviously there are a lot of quick guys in the Supercup," said 2014 champion Webster. "I wouldn't say it's a massive step up because Carrera Cup GB this year is really competitive."

Cammish, who drives for Redline Racing, added: "I raced last weekend at the Lausitzring [in the German Carrera Cup], which was effectively the same grid as Supercup. For sure it's a slight step up in competition, but I still fared well and that was a new track to me."

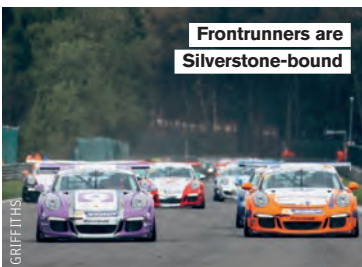

Frontrunners are Silverstone-bound



Porsche racer unhurt in huge shunt

Porsche Carrera Cup GB racer Peter Kyle-Henney was unhurt in an accident in the opening race of last weekend's round at Oulton Park. He clashed with rival Graeme Mundy at Old Hall, sending Kyle-Henney wide and tipping him into a barrel roll into the barriers. He was taken to the circuit medical centre from where he was discharged.

Le Mans 24 Hours

Bell set for Mirage reunion

LE MANS LEGEND DEREK BELL will be reunited with two of the cars he raced in the 24 Hours at this weekend's 83rd running of the enduro.

Gulf Oil is celebrating the 40th anniversary of Bell's 1975 Le Mans victory with Jacky Ickx and the Mirage-Ford GR8. The winning chassis, which is now owned by Roald Goethe's RofGo Collection, will be on display in the Le Mans museum as part of the celebrations from Friday through to Sunday night.

The five-time Le Mans winner will also take part in the on-track parade of McLaren F1 GTs to mark the 20th anniversary of the British marque's 1995

win. Bell will drive the Harrods-liveried McLaren in which he finish third in the 24 Hours in 1995 and sixth in 1996.

Bell said: "It's good that the '75 victory is being remembered, because people forget that I did win at Le Mans when I wasn't driving a Porsche."



1975 win will be honoured

HUMBLE PYE

The voice of club racing



Gilles doubled up in ERA R3A

"LINCOLNSHIRE'S FINEST REUNITED AT CADWELL PARK"

Majestic Cadwell Park, high in Lincolnshire's Wolds, is a wonderful place to spend a glorious summer's day. With the sun shining and the race programme peppered with some of the world's finest historic racing cars, including original ERAs, Rileys, Frazer Nashes and Morgan three-wheelers, it's nigh-on unbeatable. Watching the old warhorses being fired through Hall Bends in practice set me up for a memorable Vintage Sports-Car Club event, a mecca for custodians of period cars and classics spanning several decades.

Few racing folk are as enthusiastic as Dick Skipworth, owner of ERA R3A, which Mark Gillies drove superbly to two victories. As he told me in the assembly area while the stunning green 1934 machine was being readied, it brought back memories. Born in neighbouring Tathwell, Dick clambered through a hole in the fence as a lad to watch the action in the 1950s, when 500cc Formula 3 cars diced on the roller coaster. Now he was fielding a famous car built 50 miles away at Bourne in the south of the county.

Driven by ERA co-founder Raymond Mays, Tim Rose-Richards, Ernst von Delius, Norman Black and Tom Wisdom under the works banner, R3A was acquired in 1937 by Charlie Martin who repainted it in his favoured red hue. Although it spent 27 years in South Africa with

Roy Hesketh (who died in WW2, although his name lived on in the Pietermaritzburg race track from 1953-'81) and Basil Beall, the car was returned to Great Britain by Peter Massey in 1965.

Hamish Moffatt and Nigel Arnold-Forster bought it in '67 and campaigned it until the '80s. After spells with Christopher Mann and Japan's Tetsuya Takahashi, Skipworth owned R3A from 1998 to 2003, before selling it to US-based Briton Rodney Smith, for whom Gillies won regularly. When Smith's widow Mary decided to part with the car last year, Dick eagerly welcomed it back under his wing.

Now 81 years old, the ERA is a five-time Goodwood Revival race winner - with 'Whizzo' Williams up in 1999, and the remainder with Gillies in the cockpit. With specialist James Ricketts preparing it 36 years after its previous appearance at Cadwell the gallant car shows no sign of slowing down.

I very much hope to see it racing in 2034, celebrating its centenary.

Marcus Pye

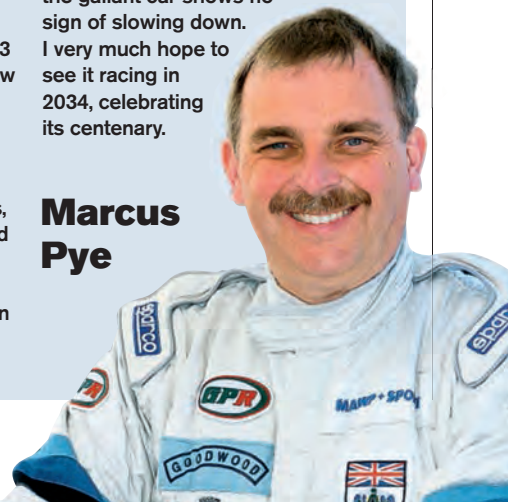

SUBSCRIBE TO AUTOSPORT AND GET...

A FREE PAIR OF HAKA SUNGLASSES

+PLUS+



**FREE DIGITAL EDITION
SUBSCRIPTION & UNLIMITED
ACCESS TO AUTOSPORT.COM**



WORTH £39

FREE GIFTS

- ✓ **FREE PAIR OF HAKA SUNGLASSES IN BLACK**
Lightweight and shatter resistant, Haka sunglasses are perfect for sport or casual wear.
- ✓ **FREE SUBSCRIPTION TO THE AUTOSPORT DIGITAL EDITION**
and unlimited access to **AUTOSPORT.com**

SUBSCRIBE NOW!



Visit: www.themagazineshop.com/taspo/m0615p

08448 488 817

Or call and quote **M0615P**
Please have your bank details ready.

Offer ends July 2 2015.

- ✓ Save 27% on the cover price
- ✓ Pay just £34.99 every 13 issues by Direct Debit

themagazineshop.com

THE BENEFITS OF SUBSCRIBING!

- ✓ Never miss an issue
- ✓ Free delivery direct to your door
- ✓ Unlimited access to news and views from the paddock
- ✓ Access to subscriber-only analysis and comment

TERMS AND CONDITIONS This offer is open to UK residents only. If you require any assistance following the purchase of your subscription, then you can speak to a member of our customer service team on 01795 592 974, calls are charged at local rate. Overseas rates are available on +44 (0) 1795 592 974. Please allow 35 days for delivery of your gift and first issue. The gift will be sent under separate cover from the magazine. Should we run out of gifts, you may be offered an alternative gift – there is no cash alternative. To activate your Autosport online account visit <https://secure.autosport.com/subs/activate.php> and enter your activation code (your personal magazine subscriber number which will be included in your welcome email/letter) along with your email address to access your extra Autosport content. Direct Debit rates are valid for one year after which they are subject to change – should prices change we will inform you in writing. We ask that you enter into a Direct Debit agreement with the intention that your subscription will continue for a minimum period of 12 months, even if the frequency of payment is for a shorter period, however, you will still have the right to cancel your Direct Debit in accordance with Direct Debit Guarantee. Should you wish to cancel your subscription it will be cancelled on expiry of the current term which will not be refundable, other than in exceptional circumstances. If a gift is included as part of the subscription offer we reserve the right to request the return of the gift. Details of the Direct Debit Guarantee are available on request. Savings are based on the standard UK cover price of £3.70. Offer ends July 2 2015. Haymarket Media Group Ltd uses a best-practice layered Privacy Policy to provide you with details about how we would like to use your personal information. To read the full privacy policy please visit our website www.haymarket.com/privacy or call us on 08448 482 800. Please ask if you have any questions as submitting your personal information indicates your consent, for the time being, that we and our partners may contact you about products and services that will be of interest to you via post, phone, e-mail and SMS. You can opt-out at ANY time by emailing the datacontroller@haymarket.com or by calling 08448 482 800.

EBREY/LAT



BRDC F4

Smaller teams the target for new F4 car

BRDC FORMULA 4 BOSSES will not chase bigger teams when the championship adopts its new, more powerful car and will instead continue to focus on helping smaller teams become better established in single-seater racing. The vast majority of the uptake for the new MSV F4-016 machine has come from the existing paddock, and so far

there have been no approaches from British powerhouse teams such as Fortec or Carlin, which currently both run in MSA Formula and European F3. "I think what's nice is that we're giving teams like HHC, Lanan and Chris Dittmann Racing the main stage – they're smaller teams, not Carlins and Fortecs," said MotorSport Vision Racing boss Jonathan Palmer. "It's nice because it

gives the smaller teams an environment to grow into big teams without being smothered by the powerhouse squads. "I'm pleased that we haven't had Carlins and Fortecs in BRDC F4, we've had smaller teams come in and flourish and win. Those fledgling teams should find themselves in demand with the new car." So far MSVR has sold 24 of the initial batch of 26 Tatuus-built cars.

Frontrunners Lanan Racing and HHC Motorsport have ordered three cars, as have Hillspeed, Sean Walkinshaw Racing and Chris Dittmann Racing. Douglas Motorsport and Mecotech Motorsport have each ordered two cars. Mark Godwin Racing, Graham Brunton Racing and two independents have yet to confirm their plans, but an unknown team has bought three cars.



Lotus 61 will be rebuilt

Historic FF1600

Eagling returns in Lotus 61

ALMOST 40 YEARS SINCE HE last raced in Formula Ford, Glenn Eagling is returning to the category in this weekend's HSCC Historic double-header at Snetterton. Eagling, 60, will drive a sister Lotus 61 'wedge' to the one in which he started his career in the early '70s. "Dad's got all excited about it, and we thought it would be fun to retrace his racing roots," said son Dan, who

has recommissioned the car, owned by Guernseyman Dave Lowe since 1970. Eagling Jr plans to totally rebuild it over the winter, alongside another 61 at Lifetime Racing. Lifetime Racing is also running an ex-Andrew Marler Lotus Elan in Saturday's Autosport 3 Hours for racing returnee Mike Goff and his son Will, who has raced in the Porsche Carrera Cup GB.

New Millennium

Cherrington to race Z3 in CSCC

FORMER LOCOST ACE MATT Cherrington will contest the remainder of the Classic Sports Car Club's New Millennium series as preparation for an endurance campaign with his recently-built BMW Z3. Cherrington will share the car with fellow former Locost driver Martin Gambling in the CSCC's series of 40-minute races, as well as in the

750 Motor Club's Roadsports mini endurance series. Cherrington and his TMC Motorsport team have built the Z3 from scratch with an eye on contesting continental 24-hour races with it in the future. "This year is about learning it and finding the potential as there's much more to come. Eventually we want to go and do full endurance races in Europe," he said.



European plans for clubbie Z3

75



Foster will join Mini grid

Mini Challenge

Front-drive debut for ex-BTCC man Foster

FORMER BRITISH TOURING CAR racer Nick Foster will make his front-wheel-drive debut in this weekend's Mini Challenge races on the Silverstone Grand Prix Circuit. Foster, 49, will handle a new two-litre F56 run by Power Maxed Racing. He will

race the car usually driven by Power Maxed boss Adam Weaver. Foster was a regular in the BTCC with the WSR BMW team, contesting four consecutive seasons until he retired from the championship at the end of 2014. "I'm really looking forward to driving

the Mini because whatever I've raced or rallied, it's always been rear-wheel-drive, so this will be a new experience for me," said Foster. "They look like well-sorted cars with good power, so basically like a mini touring car. I'll have my first laps in the car on Friday."

Vilarino leads
from Iannetta



AMERICAN SPEEDFEST BRANDS HATCH, JUNE 6-7 NASCAR EURO SERIES

Vilarino and Iannetta share the spoils

76

SPANISH DRIVER ANDER VILARINO and Frenchman Romain Iannetta split the NASCAR Euro Series victories during the third annual American Speedfest.

The Speedfest drew a big crowd to Brands Hatch and was highlighted by four NASCAR-associated races full of hectic action, as well as a host of off-track events. There was even an Earnhardt on the scene to add authenticity.

Poleman Nicolo Rocca had a frantic time on his way to a non-running 18th in Saturday's division one opener. An excursion dropped him from first to fourth and he blundered into the back of Eddie Cheever III's car at a green-flag restart. After contact with Vilarino he took fourth place, but a brutal, if successful, passing move at Clearways by Alon Day left Rocca in the gravel trap. Iannetta won from Fredric Gabillon, with Vilarino and Cheever next and reigning champion Anthony Kumphen fifth.

Jeffrey Earnhardt, grandson of Dale Earnhardt Sr and Dale Junior's nephew, beached at Clearways after running in midfield.

Vilarino became the first repeat winner of the year in Sunday's race, which was heavily delayed when Wilfried Boucenna was nudged off at Paddock and collected Michela Cerruti. Vilarino squeezed past Iannetta on lap nine of the rerun and the leaders had a useful advantage



Boucenna suffered huge crash

after Kumphen and Cheever collided in a disagreement over third place. Things closed up again during a caution period to rescue a beached car, and in the final laps there was a bit more shuffling of the order behind Vilarino, Iannetta and Israeli driver Day.

Saturday's race for second-division drivers was a protracted affair. Third qualifier Thomas Ferrando knocked front-row man Stienes Longin into the first-corner gravel trap, causing a caution period, then a red flag. The clock remained ticking while the cars stood on the grid, so that the final race average speed was only 47mph.

Florian Renauer was the winner and Philipp Lietz beat Salvador Tineo Arroyo to second by a couple of lengths.

The second race proceeded uneventfully until a collision caused an 11-lap caution period to mop up a trail of oil from Druids to Surtees. Then, in the final moments of a short dash to the flag, two tail-enders had a huge crash opposite the pits with the leaders already on their last lap. Ferrando slowed past the scene to take the flag from Tineo Arroyo and Bert Longin.

Billed as the SpeedFest Silhouettes, races six and seven in the 2015 **Intermarque championship** produced wins for points leader Malcolm Blackman and reigning champion Matt Simpson in their Vauxhall Tigras.

Blackman led Simpson in race one while Lewis Smith recovered from a poor start, but Smith took over when the leaders strayed through

the gravel trap at a slippery Paddock, bringing Chris Brockhurst into the reckoning. Then Smith had problems, and in a key moment Blackman, Brockhurst and Smith were three abreast on Graham Hill as Lewis headed for retirement with a puncture.

Simpson was out with a broken oil pipe, so Blackman triumphed over Brockhurst, with David Brooks third and Chris Ayling fourth, also winning the senior cup class for older drivers.

The top seven were reversed for race two, and from the fourth row Blackman was lucky to survive a clash with Brooks before they reached the first corner. There were more casualties at Druids, and through the confusion Philip Young briefly led Simpson (from 12th on the grid), Mike Thurley and Brockhurst.

A caution period helped Blackman back into contention, and once up to full speed the race lay between Simpson, Blackman and Brockhurst. Blackman closed in, but Simpson had things under control.

Simon Smith was fourth after retiring in race one, and fifth was the subject of a duel between Richard Smith and Thurley for the honour of being the leading senior. Richard got the verdict, but both skated off after the flag at Paddock, where Ricky Hunn had deposited oil.

● Brian Phillips



HAWKINS



Harrison and Watts
Volvo starred

HAWKINS

Harrison turns up the Watts in tin-top encounter

MALCOLM HARRISON AND PATRICK WATTS took their shared Volvo to victory in an entertaining **Touring Car Greats** pitstopper. The Richard Butterfield/Peter Dorlin Jaguar lost second place with a short gravel-trap visit before finishing fourth. Between the two came Matthew Moore's Austin A40 and Gavin Watson's Alfa.

Two **Anglo-American F5000** races made all the right noises, but lacked much competitive element. Michael Lyons's Eagle lapped everyone at least once on Sunday morning, but only won race two by 11s following a caution period. Greg Thornton had a brace of second places in his Surtees.

A rapid getaway helped Lee Cunningham to defend a narrow lead over the clearly faster Marc Mercer throughout the first **Atom Cup** race. Mercer made amends at the second attempt and headed into the distance.

Richard Skinner's Marcos was never under threat in the **HRDC Allstars** race. He backed off at the end, allowing Bill Shepherd's

Mustang to close up, while John Young's Jaguar E-type was the only other car on the same lap.

Poleman Barry Liversidge enlivened the first **Allcomers** race by stalling his Radical at the start. A caution period helped him to close up but left him too little time to rise higher than third, with Simon Smith (Caterham) and David Krayem (Ginetta G50) ahead. Liversidge made no mistake in race two and won comfortably.

Kevin Bottomley and James Gowens clashed wheels and crashed out of the **Champion of Brands FF1600** race on lap one. When the action resumed after a caution period, Neil Tofts had to work hard to keep Andy Charsley and Ashley Dibden at bay.

Dean Cook won both the **Bernie's V8s** races in his TVR. William Smallridge fancied his chances in race one until the brakes of his Sunbeam Tiger went missing, and he finished somewhat closer in the second race, which featured mandatory pitstops.



Blackman out front from Simpson

HAWKINS

RESULTS

NASCAR EURO SERIES ELITE 1 (30 LAPS) 1 Romain Iannetta 27m15.690s (79.75mph); 2 Fredric Gabillon +0.951s; 3 Ander Vilarino; 4 Eddie Cheever III; 5 Anthony Kumpen; 6 Florian Renauer. **Fastest lap** Iannetta 49.664s (87.56mph). **Pole** Nicolò Rocca. **Starters** 23. **RACE 2 (30 LAPS)** 1 Vilarino 1h10m45.670s (30.72mph); 2 Iannetta +0.884s; 3 Alon Day; 4 Renauer; 5 Kumpen; 6 Bert Longin. **FL** Iannetta 49.925s (87.10mph). **P** Iannetta. **S** 23. **ELITE 2 (30 LAPS)** 1 Renauer 45m59.250s (47.28mph); 2 Philipp Lietz +3.643s; 3 Salvador Tineo Arroyo; 4 Nicki Petersen; 5 Gianmarco Ercoli; 6 Eric de Doncker. **FL** Thomas Ferrando 50.310s (86.43mph). **P** Renauer. **S** 23. **RACE 2 (30 LAPS)** 1 Ferrando 35m30.635s (61.22mph); 2 Tineo Arroyo +0.267s; 3 Longin; 4 Renauer; 5 Lietz; 6 Maxime Dumarey. **FL** Ferrando 49.956s (87.04mph). **P** Ferrando. **S** 21. **SPEEDFEST SILHOUETTES (18 LAPS)** 1 Malcolm Blackman (Vauxhall Tigra) 15m20.835s (85.00mph); 2 Chris Brockhurst (Vauxhall Tigra) +0.151s; 3 David Brooks (Vauxhall Tigra); 4 Chris Ayling (Vauxhall Tigra); 5 Ross Loram (Vauxhall Tigra); 6 Paul Adams (Mercedes SLK). **Class winner** Ayling.

FL Lewis Smith (Vauxhall Tigra) 49.271s (88.25mph). **P** Matt Simpson (Vauxhall Tigra). **S** 18. **RACE 2 (15 LAPS)** 1 Simpson 15m14.578s (71.32mph); 2 Blackman +0.620s; 3 Brockhurst; 4 Simon Smith (BMW Z4); 5 Richard Smith (Mercedes SLK); 6 Mike Thurley (Vauxhall Tigra). **CW** R Smith. **FL** Blackman 49.474s (87.89mph). **P** Philip Young (Mitsubishi Colt). **S** 18. **ANGLO-AMERICAN F5000 (21 LAPS)** 1 Michael Lyons (Eagle FA74) 15m41.912s (96.95mph); 2 Greg Thornton (Surtees TS11) -1 lap; 3 Neil Glover (Chevron B37); 4 Paul Campfield (Chevron B24); 5 Daryl Taylor (Lola T332); 6 Simon Taylor (Chevron B28). **CW** Frank Lyons (McRae GM1). **FL** M Lyons 43.681s (99.55mph). **P** M Lyons. **S** 12. **RACE 2 (17 LAPS)** 1 M Lyons 15m13.529s (80.92mph); 2 Thornton +11.106s; 3 Glover; 4 Campfield; 5 Chris Atkinson (Surtees TS8); 6 F Lyons. **CW** Atkinson. **FL** M Lyons 44.002s (98.82mph). **P** M Lyons. **S** 9. **HRDC TOURING CAR GREATS (43 LAPS)** 1 Malcolm Harrison/Patrick Watts (Volvo Amazon) 45m34.710s (68.37mph); 2 Matthew Moore (Austin A40) +8.750s; 3 Gavin Watson (Alfa Romeo Giulietta Ti); 4 Richard Butterfield/Peter Dorlin (Jaguar Mk1); 5 Tom Shephard

(Alfa Romeo Giulietta Ti); 6 Nick Naismith/Phil Perryman (Austin A95). **CW** Moore; Watson; Butterfield/Dorlin; Mike & Marc Koskela (Ford Prefect 107E); David Lillywhite (Austin A35). **FL** Watts 1m00.995s (71.29mph). **P** Harrison/Watts. **S** 30. **ATOM CUP (23 LAPS)** 1 Lee Cunningham 20m18.320s (82.09mph); 2 Marc Mercer +0.492s; 3 Richard Marler; 4 Stewart Lyddell; 5 Lewis Cook; 6 Gus Desbarats. **FL** Mercer 52.413s (82.96mph). **P** Mercer. **S** 6. **RACE 2 (23 LAPS)** 1 Mercer 20m06.629s (82.89mph); 2 Cunningham +17.871s; 3 Marler; 4 Lyddell; 5 Cook; 6 Desbarats. **FL** Mercer 51.928s (83.74mph). **P** Lyddell. **S** 6. **HRDC ALL-STARS PRE-1966 SPORTS, GT & TOURING CARS (31 LAPS)** 1 Richard Skinner (Marcos GT) 30m43.067s (73.14mph); 2 Bill Shepherd (Ford Mustang) +2.385s; 3 John Young (Jaguar E-type); 4 Joe Allenby-Byrne (Ford Cortina GT); 5 Brian Small (Ford Anglia); 6 Dave Koskela (Ford Anglia). **CW** Shepherd; Allenby-Byrne; Small; Marc Gordon (Jaguar XK150). **FL** Skinner 57.261s (75.94mph). **P** Skinner. **S** 26. **ALLCOMERS SPORTS & GT CARS (14 LAPS)** 1 Simon Smith (Caterham CSR) 15m12.188s (66.74mph); 2 David Krayem (Ginetta G50) +2.729s; 3 Barry

Liversidge (Radical SR1); 4 Rick de Blaby (Crosle 95); 5 Nick Starkey (Caterham Superlight); 6 Michael Benham (Caterham R300). **FL** Krayem 50.030s (86.91mph). **P** Liversidge. **S** 11. **CHAMPION OF BRANDS FF1600 (15 LAPS)** 1 Neil Tofts (Mygale SJ08) 15m02.469s (72.27mph); 2 Andy Charsley (Ray GR15) +1.152s; 3 Ashley Dibden (Mygale SJ01); 4 Mike Thompson (Quest); 5 Simon Hadfield (Van Diemen RF91); 6 Miles Johnston (Mygale). **FL** Dibden 51.092s (85.11mph). **P** Tofts. **S** 14. **BERNIE'S V8S (15 LAPS)** 1 Dean Cook (TVR Sagaris) 16m36.730s (65.44mph); 2 William Smallridge (Sunbeam Tiger) +9.470s; 3 Cheng Lim (RAM SC); 4 Simon Cripps (MGB V8); 5 Andy Race (TVR Tuscan); 6 Tom Barley (Chevrolet Camaro). **CW** Smallridge; Lim; Robin Gray (Pontiac Trans Am); Mark Bowd (Ford GT40). **FL** Cook 51.774s (83.99mph). **P** Cook. **S** 33. **RACE 2 (33 LAPS)** 1 Cook 30m52.381s (77.46mph); 2 Smallridge +1.514s; 3 Cripps; 4 Barley; 5 Jan Schippers (Chevrolet Camaro); 6 Leo Voyatzides (Ford Mustang). **CW** Smallridge; Phil Jame/Andrew Riley (MGB V8); Bowd. **FL** Cook 51.878s (83.82mph). **P** Cook. **S** 26.



DONINGTON PARK, JUNE 6-7 BARC

Gibsons junior and senior do the double

FATHER-AND-SON DUO PAUL AND Daniel Gibson delivered a pair of brilliant wins to help the Clubmans Cup celebrate its 50th Anniversary weekend at Donington.

Daniel, son of Paul, struggled with the tyres on his car in qualifying, managing third behind his dad and poleman Mark Charteris. With the Mallock quicker at starts, Charteris pulled out a narrow advantage early as Gibson Jr sat behind Senior. "Early in the lap I overreached and nearly took him off at the Old Hairpin," said Daniel. "Then I had a go at the chicane and wish I hadn't."

There was no love lost between the pair as they were panel-to-panel on many occasions before Gibson Jr muscled past on lap five, setting the fastest lap in the process. Then he was on to Charteris in a flash, and in a few laps he was past him at the Melbourne Hairpin, with an awkwardly placed backmarker failing to hinder Gibson's push for the lead.



Jones and Crossley in pre-'66 action



Spectacular Philpotts starred in his Starion

"It's a nice piece of history," Daniel enthused. The second instalment couldn't have started much worse for him, though, as an intermittent electronic misfire plagued his qualifying and race performance. "The car just switches itself completely off," said Gibson Jr. "I had so much more in the car, it only revved to seven [thousand rpm] and it can do eight. There was more pace in the car, it was so frustrating."

He could only manage eighth on the grid, but he was soon up into third by the end of the first lap. The misfire struck repeatedly though, and he backed off to risk damaging the car. At the front, Charteris again got a great start and built a narrow margin, before the race came back towards Gibson Sr. Charteris seemed to struggle with traffic more than Gibson, and the gap between the two was soon down to nothing.

Gibson went wide at Redgate but executed the switchback perfectly as he got a fantastic run off the corner and moved into a lead he wouldn't cede. "It's always nice to beat Daniel," joked dad Paul. "I snapped a rear anti-roll bar after two or three laps, so we just bided our time and it paid off." Charteris held second, which was also enough to give him a pair of Classic-division class wins after his earlier triumph, with Gibson Jr hanging onto third.

Neil Philpotts and Ryan Gorman split the **Pre-83/Pre-93 Classic Touring Car** victories. Philpotts exited Goddards on the last lap completely sideways and his Starion was heading for the pitwall in what could have been a nasty accident, but he recovered magnificently and held off Malcolm Wise by 0.158s. Ryan Gorman managed third in his BMW M3, and came off better to win the

second race after a battle with Philpotts. Dave Howard's purring Jag rounded out the top three.

Vaughan Fletcher used his four-wheel-drive Subaru Impreza to keep Ford Falcon V8 Supercar driver Andy Robinson at bay in **Classic Thunder**. He maintained a 3s lead over Robinson for the first race to take victory, with the flame-spitting Escort Cosworth of Dave Cockell third. Cockell bided his time in the race two, pouncing on Robinson as he ran wide exiting Goddards to take second behind Vaughan.

Pat Gormley drove away from Ian Pearson to win the first **Classic Formula Ford 2000** race, but the second instalment was changed by Gormley pitting on his outlap. He worked his way up to second, but Pearson had built up enough of a gap to take the win by over 15s.

Steven Sprigg pulled off one of the drives of the day on Saturday from the back of the **Pre-66 Classic & Historic Touring Car Championship**. A technical infringement meant he was disqualified from his poleworthy qualifying lap, but he came from the back to lead by the second lap. Sprigg was absent in the second race, leaving fellow Cortina man Eifion Jones to battle to a victory, under pressure from the Mini of Julian Crossley.

Polesitter Andrew Rogerson won the **MG Owners' Club** race of just

CADWELL PARK, JUNE 7 VSCC

Marque specialist Gillies wins on ERA homecoming

DRIVING AN ERA AT ITS spiritual home for the first time, renowned marque tamer Mark Gillies blitzed the feature **Shuttleworth & Nuffield Trophies** race in local lad Dick Skipworth's Lincoln green R3A on the Vintage Sports-Car Club's annual visit to Cadwell Park.

"A Lincolnshire car, owner and track: what could be better?" said the US-based Briton.

"I made a start which was pretty spectacular, but the ERA is magic here, the perfect car for this circuit. It's a bit scary at times, because you are hanging it out, but brilliant fun," added Gillies, who supported father Barrie (competing in his Riley Treen) on the VSCC's first visit in 1979 and last raced his Lotus 22 here in 2007.

Fred Harper pushed Gillies hardest in his Offenhauser-engined 1957 Kurtis Indy Roadster – is there a less suitable bolide for the Wolds switchback? – while Clive Wilson (ex-Jack Brabham Cooper T43) took third from Nick Topliss in ERA R4A.

Topliss was ahead for a few yards as Gillies spun his wheels at the start of the programme closer, but scorched ahead at Coppice to land a memorable double. Julian Grimwade's Alvis-engined Frazer Nash single-seater threatened Topliss's second place, but Nick held on for an ERA one-two.

There was further joy for R3A's preparers James and Elaine Ricketts in the **Riley Trophy** event (the first to remember Garry Whyte), when an ecstatic Nick Hayward-Cook overcame a 40-second handicap to win in his Monoposto 9. "It's the first time



The Frazer Nash race gets going

it's run really well," said the Austin 7 stalwart, who outran John Collins's 'Brooker' and Simon Kelleway's Sprite Special.

William Mahany also scored twice at his favourite circuit in his elegantly-driven HRG. Mahany's 10th **Spero Trophy** in 11 years (Christian Pedersen broke the sequence last year) came after victory over fellow Hurgmeister Andrew Mitchell in the Owner-Driver-Mechanic series counter in which fourth-placed Jo Blakeney-Edwards (Frazer Super Sports) won the annual **Geoghegan Trophy**.

Former BTRDA rally champion Richard Iliffe was a surprise winner of the **Melville Trophy** race in his long-serving Riley Kestrel Special after leader Brian White's race in the rorty BMW-engined Frazer Nash ended at Chris Curves. Cadwell debutant David Pryke shadowed Iliffe over the line with Charles Jones, also sampling its delights for the first time, third.

Charles Gillett fishtailed his blue **Frazer Nash Super Sports** to a consummate victory over the whirring FN/GN (Godfrey Nash) pack, pursued by the svelte AC/GNs

of Robert Carr and Tony Lees. "I'm so pleased to have finished a race for the first time in three years," grinned Lees.

The **Morgan Three-Wheeler** opener [including two of the modern S&S-powered cars] was red-flagged when father and daughter Anthony and Verity Pearson crashed at Park on the first lap, happily without major injury. At the restart, Hamish Bibby gave a masterclass in passenger Bill Tuer's battleship grey JAP-powered machine, avenging dad Greg's masterful win in the wet last year.

Bill Cleyndert (Wolseley Hornet Special) and Simon Kelleway (Riley Sprite 12/4 Special) won the short **Vintage Handicaps**. Cleyndert was chased home by Richard Lake's red Aston Martin 15/98 Speed Model and Andrew Kellock's AC-engined Fiat confection. Novice Philip Bewley wound his Bugatti T35 up well to split the Rileys in the second one, in which Roland Woodtli's 15/6 Special caught the eye.

● Marcus Pye



Charteris leads away in Clubmans 50th



John Village took first comeback win

three laps, thanks to a crash involving three cars at the Esses. The second race ran to distance, with a repeat of the top three. Rogerson won by 7.715s.

John Village opened Sunday with a victory in the first finish of his **Formula Ford 1600** comeback tour. He retired last time at Oulton, but jumped Stuart Kestenbaum with a few minutes remaining after consecutive failed attempts at McLeans. Kestenbaum again managed runner-up in the second encounter, but this time it was Mike Gardner who took the top step. Village rounded out the podium.

Andy Thompson was the comfortable class of the combined **Pre-03/Pre-05/BOSS** and **VW** field. The SEAT Leon driver headed both races with fastest laps, just over 4s ahead of Olly Allen's Ford Fiesta.

● Jack Benyon

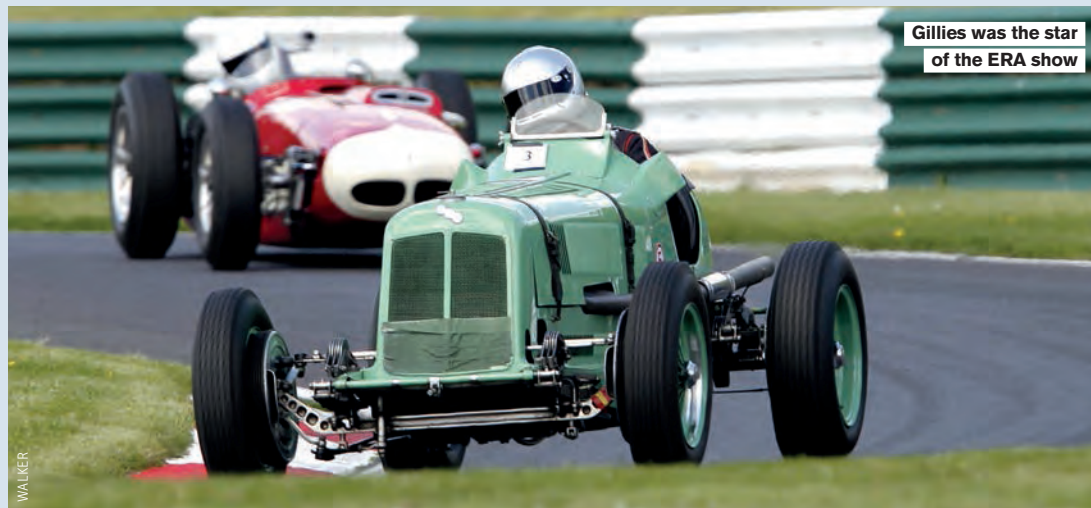

Gillies was the star of the ERA show



SILVERSTONE, JUNE 6-7 BRSCC

Woodward and Kaiser do the double

TERENCE WOODWARD AND ROSS

Kaiser took their Radical SR8 to a winning double, but had to fight hard to see off the charging Jamie Patterson and Alex Kapadia in both of the weekend's races.

Patterson got an early break after James Abbott spun at Copse and made contact with Woodward. Jon Harrison was into second, but Woodward recovered and passed him into Stowe on the second lap.

Woodward was close enough to threaten Patterson's lead as the pitstop window opened, while Harrison held onto third until the lap before his stop, when Chris Hyman got by at Village.

Although Kapadia took over the lead car and retained the advantage, he had Kaiser soon hunting him

down. Time began to run out, though, and Kapadia's defence continued to hold firm with a 0.266s lead and five minutes left.

They came through Woodcote virtually side by side to start the last lap but Kaiser nosed clear at Copse to snatch victory. Alex Mortimer/Hyman completed the podium, with Alain Costa fourth, after Victor Correa/Harrison ran out of fuel with two laps to go. Chris Hoy and Ozzy Yusuf completed the top six.

Peter Belshaw/Phil Keen topped the SR3 class from Marcelo Marateotto/Marco Cencetti. Stuart Mosley/Hui Sun Kim were third.

Correa just edged out Woodward to lead race two, with Patterson and Hyman in contention too. But a

safety car intervention after five laps restricted Correa's hopes of building a lead and he handed to Harrison only marginally ahead of his rivals.

Harrison was still ahead as they rejoined, while Kaiser was chasing Kapadia again for fourth. An uncharacteristic slip from Kapadia on lap 12 allowed Kaiser to nose alongside into the Loop, before they swapped a couple of times and Kaiser finally made it stick. "Side by side through Vale and Club – I would only do that with Alex as I trust him," said Kaiser.

They both saw off Yusuf and began to reel in Harrison's lead. But Kaiser's charge continued and he dived inside Harrison at Brooklands on lap 16 to secure win number two. Kapadia followed to claim second two laps later, with Hyman/Mortimer demoting Yusuf for fourth on the last lap. "The safety car at the beginning of the second race certainly helped us," said Woodward.

Marateotto/Cencetti took the SR3 spoils after taking Shahin Nouri just after the stops, with Belshaw/Keen third behind Nouri. Stian Paulsen just held onto his race-long lead in the **SEAT Leon Eurocup**, as reigning champion Pol Rosell took eight laps to breach

Mikel Azcona's hold on to second placen into the Loop. "One more lap and he would have got me too," said Paulsen.

Jonathan Cocker won the second race from pole, with Alex Morgan finishing second.

One mistake from Vitor Baptista proved costly in the first **Euroformula Open** race, as Yu Kanamaru made the decisive move. Alessio Rovera was third throughout, having shaken off an early challenge from Yarin Stern.

Konstantin Tereshchenko and Vitor Baptista's early duel in race two was finally split after both made deliberate contact. Kanamaru split them on lap six and just missed out on a second win, as Tereshchenko triumphed, while Baptista led home a five-car scrap for third.

Only 12 cars turned out in the **International GT Open**. Alvaro Parente's McLaren 650S led until the pitstops, but co-driver Miguel Ramos took until two laps from home to clinch the victory over Alessandro Balzan/Nicola Benucci's Ferrari 458.

Ezequiel Compagnon and Raffaele Giammaria won the second race.

Chris Rees snatched a last-lap victory in the first **Radical SR1 Cup** race. He had swapped and

Cocker won second SEAT Leon race





SR8 battle went down to the wire

READ



Tereshchenko took win after crash

READ

changed with Dave Morgan until debutant Mark Richards split them, and then led into Village on lap five. But Rees came back to make his late move at Brooklands, with Rob Watkins a close third.

A possible double was on the cards for Rees, but Watkins had the edge for the majority of the second race. At the finish, only 0.839s covered the top four with Watkins heading Rees, Gee and Morgan.

With the SR8 of Alex Mortimer/Chris Hyman and Chris Hoy's Spyder both cutting out in the closing stages, the fight for victory in the **Radical Enduro** came down to three cars. Grahame Tilley/Rob Bell led but time was running out despite Phil Keen/Peter Belshaw and Harry/Ed Cockill closing in.

On the last lap, Tilley ran wide at Village, and it was enough for Keen to snatch the win.

● Peter Scherer



CHESTER

Thompson won in his family-built TMC Costin

MONDELLO PARK, JUNE 6-7 MEC

Win Costin' nothing for Thompson on debut win

VAL THOMPSON CREATED A

little bit of history at Mondello Park on Sunday, as he took his first ever win in the **HRCA** race, at the wheel of the car his family produced – the TMC Costin.

Thompson tracked long-time leader Steve Griffin before slicing his more modern machine by the Modsport Midget and holding on to the flag. In race two, Griffin, in his fifth decade racing at the Kildare venue, was more determined, and led from lights to flag, with Thompson parking in the kitty litter mid-race. Paul Gray was next up, with Will Corry's beautifully driven Sebring Sprite somehow beating Michael Doyle's BDG Elan to the final podium spot.

Ray Moore took **Formula Vee** victory after pursuers Dan Polley and Jimmy Furlong spent the early stages scrapping amongst themselves. In the earlier qualifier, early leader Des Foley retired with suspension failure, and Gavin Buckley subsequently

rotated leaving Anthony Cross to take an easy win, from the impressive Paula Moore.

An on-form Enda O'Connor dominated both Formula Sheane races from pole, Brian Hearty climbing to second in the first race, whilst David Parks was O'Connor's closest challenger in race two.

Eoghan Fogarty took his first **Irish Touring Car** win in the ex-Holstein BMW M3, fighting off the charging Rob Savage in the closing stages with Gareth Hayden not too far away in third. Steven Dunne took Touring Class honours from Nicole Drought and Robert Doherty.

In the concurrently-run **SEAT Supercup**, Niall Quinn dominated from John Farrelly and slow-starting polesitter Niall Murray. In race two, Shane Rabbitt's distinctive-sounding rotary-engined Mazda RX-7 blasted into the lead and controlled the gap to Eric Carroll and Rob Savage beautifully until the final lap. Even with the maximum 40 litres on board, the Mazda ran

dry and a gutted Rabbitt stuttered across the line for fourth. O'Driscoll took Touring class honours after a great battle with Grzegorz Kalinecki. Helped by a reverse grid, Michael Cullen took the Supercup honours, from Brian Berry and Niall Quinn.

Dan Byrne's Chevette led the Punto-mounted pairing of Brendan Travers and Eoghan O'Brien across the line in **Future Classics**, but with the barrier time being broken by many of the competitors, it was Robbie Parks who got the verdict, from Ian Thornton and Aidan Byrne.

Sean Doyle continued his unbeaten run of victories in the **ASK Supercar Championship**, despite the close attentions of Peter Barrable for the duration. In race two, Barrable got the jump and Graeme Colfer also got ahead of Doyle on the run to turn one. Doyle attempted to take the place back with a lunge down the inside but ran out of room and carnage ensued. At the flag, Barrable took an easy win from Bob Cameron and Philip Jones.

Alan Auerbach took two **Stryker** wins, despite the best attentions of multiple champion Alan Watkins, the pair clearly on the limit in both counters.

Collie Barrable won **Fiesta** qualifier one, with Barry Rabbitt beating polesitter Brendan Fitzgerald to the flag in the main race. Second time round, Keith Dawson was first home in the qualifier, whilst Fitzgerald held off Rabbitt for his debut win.

● Leo Nulty



Moore pulled away as others dived

CHESTER



Goodyear wins at Shelsley again

SHELSLEY WALSH BRITISH HILLCLIMB CHAMPIONSHIP, JUNE 6-7

Goodyear doesn't tire of victories

JOS GOODYEAR PROVED THAT HIS August 2014 single victory at the oldest hillclimb track of all was no fluke by taking another in round nine last weekend, also grabbing Best Time of the Day with a two-litre class win – a feat unheard of in dry conditions where the maximum efforts normally occur in the run-offs.

“I’ve surprised myself by getting BTM from the class runs and the run-off victory was very hard,” said Goodyear as he received his BTM award from Midland Automobile Club president John Moody. “In the second, I bogged down badly off the start, then got the wrong gear at Kennel.”

Alex Summers, coached by Roger Moran, drove with enormous maturity all weekend and continues to lead the championship. He was fastest qualifier for round nine and brought the car home safely on every run. Even so, Summers was outscored by co-driver and highest scorer of the day Scott Moran on 19 points, Moran taking round 10 having followed Goodyear home in the first of the shoot-outs.

Moran moved into overall second ahead of Trevor Willis, whose car got unsettled into Ess Approach in round nine and spun in the middle of the infamous Esses, knocking the entire rear-wing assembly off the car. Willis was back later for third behind the legendary Moran/Moran/Summers GR61X, which has now taken an incredible 144 championship rounds.

Goodyear fancies his chances at next weekend's Loton Park rounds, where he briefly held the hill record two seasons ago. He is now only five points behind fifth-in-the-championship Wallace Menzies in the Gould

formerly driven by four-time champion Martin Groves. Menzies' co-driver Tom New qualified well each time (fifth and fourth), and finished in the same positions. This moved him to within two points of Alastair Crawford, who was driving as smoothly as ever.

Dave Uren had mixed fortunes, qualifying sixth fastest for round nine and finishing eighth. Qualifying seventh later, he was one of the day's many victims of the daunting, and famously haunted, high-banked Esses in that final shoot-out. Similarly hexed by the Shelsley spooks, Will Hall qualified eighth for round nine. He improved to fourth but his gearbox cried enough after qualifying fifth for the last stanza and he was unable to get to the start.

Uren's misfortune in round 10 played into the hands of Paul Haimes, who held on to 10th overall with gritty performances after his turbo plenum sprung a leak in Saturday practice. He is a solitary point ahead of Uren with a long way to go this season.

Ed Hollier again qualified for a run-off but the merciless Shelsley pace outfoxed him. Also with only 1600cc at his disposal, Eynon Price is a former British number 10. Uren and Hall's difficulties handed Price a point just for finishing.

John Bradburn thoroughly enjoyed his weekend, despite a meagre six points, taking great pleasure in describing a couple of big moments that slowed his progress somewhat.

The award of Man of the Meeting went to Martin Spencer, who drove one of the famous Shelsley Specials to a time quicker than Raymond Mays's pre-war ERA hill record.

● Eddie Walder

RESULTS

DONINGTON PARK
BARC, JUNE 6-7



CLUBMANS CHAMPIONSHIP (9 LAPS) 1 Daniel Gibson (Nemesis K11 Proto) 14m12.557s (94.36mph); 2 Mark Charteris (Mallock Mk20B) +0.423s; 3 Paul Gibson (Nemesis K11 Proto); 4 Alex Champkin (Vision V84); 5 Alan Cook (Mallock Mk20b/21); 6 Chris Pickering (Mallock Mk27 EBX). **Class winners** Charteris; Alex Champkin (Vision V84); Clive Wood (Mallock Mk20); Robert Yarwood (Ladybird Clubmans Mk6B). **Fastest lap** D Gibson 1m32.502s (96.80mph). **Pole** Charteris.

Starters 29. RACE 2 (9 LAPS) 1 P Gibson 14m04.828s (95.23mph); 2 Charteris; 3 D Gibson; 4 Onno Zuidema (Mallock Mk27 SG); 5 Cook; 6 Robert Manson (Mallock Mk21). **CW** Charteris; Champkin; Barry Webb (Mallock Mk16 BW); John Muirhead (Lotus Super Seven 1600). **FL** Charteris 1m31.748s (97.59mph). **P** Charteris. **S 31.**

PRE '83 TOURING CARS/PRE '93 TOURING CARS (9 LAPS) 1 Neil Philpotts (Mitsubishi Starion) 16m46.412s (79.94mph); 2 Malcolm Wise (Ford Sapphire Cosworth) +0.158s; 3 Ryan Gorman (BMW M3); 4 David Howard (Jaguar XJ12); 5 Stephen Primett (Ford Escort); 6 Neil Bray (BMW M3). **CW** Howard; Primett; Simon Ward (Vauxhall Astra GTE 16V); Mark Fowler (Ford Capri); Michael Sheraton (BMW E30); Andrew Smith (Honda CRX); Simon Jeffs (Alfa Romeo Alfasud 1.3Ti Autodelta Trofeo). **FL** Philpotts 1m50.026s (81.38mph). **P** Wise. **S 20. RACE 2 (7 LAPS) 1 Gorman 12m57.783s (80.41mph);** 2 Philpotts +0.255s; 3 Howard; 4 Wise; 5 Ward; 6 Bray. **CW** Howard; Ward; Mostyn Rutter (Vauxhall Firenza); Richard Harrison (BMW E30); Smith; Jeffs. **FL** Philpotts 1m48.576s (82.47mph). **S 19.**

CLASSIC THUNDER CHAMPIONSHIP (7 LAPS) 1 Vaughan Fletcher (Subaru Impreza) 11m47.294s (88.42mph); 2 Andy Robinson (Ford Falcon V8 Supercar) +3.640s; 3 Dave Cockell (Ford Escort Cosworth); 4 Darren Bly (Nissan Skyline); 5 Steven Wood (Ford Mustang FR500); 6 David Matthias (Ford Escort Cosworth).

CW Robinson; Bradley Gelman (Ford Sierra Cosworth); Bob Hosier (SEAT Leon). **FL** Fletcher 1m39.307s (90.16mph). **P** Fletcher. **S 17. RACE 2 (7 LAPS) 1 Fletcher 13m24.429s (88.88mph);** 2 Cockell +1.958s; 3 Robinson; 4 Ilsa Cox (SEAT Leon Cupra); 5 Kevin Wendt (BMW M3 E46); 6 Andrew Wilson (Vauxhall Holden Monaro). **CW** Robinson; Cox; Hosier. **FL** Robinson 1m38.908s (90.53mph). **S 15.**

FORMULA FORD 2000 SERIES (8 LAPS) 1 Pat Gormley (Safir Classic F3) 13m28.769s (88.40mph); 2 Tony Hancock (Van Diemen RF82) +5.984s; 3 Christopher Levy (Van Diemen RF83); 4 Clive Wood (Van Diemen RF82); 5 Christopher Lord (Van Diemen RF82); 6 Robert Pearson (Van Diemen RF82). **CW** Rodney Toft (Van Diemen RF82). **FL** Hancock 1m39.909s (89.62mph). **P** Gormley. **S 11. RACE 2 (8 LAPS) 1 Pearson 13m12.703s (90.19mph);** 2 Gormley +15.080s; 3 Lord; 4 Levy; 5 Wood; 6 Graham Ridgeway (Reynard SF78). **CW** Ridgeway; Toft. **S 10.**

CLASSIC SALOON & HISTORIC TOURING CAR CHAMPIONSHIP (6 LAPS) 1 Steven Sprigg (Ford Lotus Cortina Mk1) 12m25.091s (71.92mph); 2 Eifion Jones (Ford Lotus Cortina Mk1) +4.625s; 3 Andy Messham (Austin Mini Seven); 4 Paul Cooper (Ford Cortina); 5 Tim Cotgrove (Ford Anglia); 6 Tony Preston (Morris Minor). **CW** Jones; Messham; Cotgrove; Gary Fletcher (Hillman Imp); Robert Strutt (Jaguar S-type). **FL** Sprigg 2m01.960s (73.42mph). **P** Jones. **S 10. RACE 2 (6 LAPS) 1 Jones 12m27.684s (71.67mph);** 2 Julian Crossley (Morris Mini) +0.964s; 3 Messham; 4 Cotgrove; 5 Cooper; 6 Fletcher. **CW** Crossley; Cotgrove; Fletcher; Strutt. **FL** Jones 2m02.034s (73.73mph). **S 11.**

MG OWNERS CLUB (3 LAPS) 1 Andrew Rogerson (ZR 160); 2 Simon Kendrick (F VVC) +1.007s; 3 Brian Butler (F); 4 Stuart Plotnek (F VVC); 5 Adam Jackson (ZR); 6 Nick Golhar (ZR). **CW** Kendrick; David Amphlett (Roadster); Russell Davison (Montego). **FL** Rogerson 1m59.161s (75.14mph). **P** Rogerson. **S 20. RACE 2 (7 LAPS) 1 Rogerson 13m37.882s (76.47mph);** 2 Kendrick +7.715s; 3 Butler; 4 Jackson; 5 Plotnek; 6 Phil Walker (ZR). **CW** Kendrick; Chris Pollard (B Roadster). **FL** Rogerson 1m55.475s (77.54mph). **P** Rogerson. **S 16.**

PRE '03/PRE '05 TOURING CARS/BOSS/VW CHALLENGE (7 LAPS) 1 Andy Thompson (SEAT Leon) 12m47.253s (81.51mph); 2 Oly Allen (Ford Fiesta) +4.783s; 3 Jim McLoughlin (Honda Integra); 4 Nick Sanderson (SEAT Leon); 5 Luke Allen (Honda Civic Type-R); 6 Alexander Owen (Honda Civic Type-R). **CW** Allen; McLoughlin; Gary Parkes (Peugeot 206 GTI 180); Tim Moll (Volkswagen Golf Mk3 VR6); Robert Hutton (Ford Sapphire Cosworth); Brian Long (Ford Fiesta); Ian Fowler (Volkswagen Golf Mk3); Kenneth Allard (Alfa Romeo 145); Damon Craig (Ford Puma); Scott Parkes (Ford Fiesta XR2); **FL** Thompson 1m46.782s (83.85mph). **P** Thompson. **S 30.**

RACE 2 (7 LAPS) 1 Thompson 12m36.162s (82.71mph); 2 O Allen +4.201s; 3 Sanderson; 4 Owen; 5 L Allen; 6 Ken Lark (Volkswagen Corrado VR6). **CW** O Allen; Owen; Anthony George (Alfa Romeo 33); Hutton; G Parkes; Fowler; Moll; Mohammed Eishimy (Peugeot 206 GTI); Demetris Neophytou (Ford Fiesta Mk1 X/Flow); Jeffrey Winsor (Ford Puma); 5 Parkes. **FL** Thompson 1m45.811s (84.62mph). **S 30.**

FORMULA FORD 1600 CHAMPIONSHIP (9 LAPS) 1 John Village (Crosle 25F) 16m02.414s (83.59mph); 2 Stuart Kestenbaum (Van Diemen RF79); 3 Mike Gardner (Crosle 30F); 4 Mike Wrigley (Merlyn MK20a); 5 Chris Stuart (Van Diemen RF80); 6 Matthew Dunne (Crosle 35F). **CW** Wrigley. **FL** Gardner 1m44.115s (86.00mph). **P** Gardner. **S 22. RACE 2 (12 LAPS) 1 Gardner;** 2 Kestenbaum +6.856s; 3 Village; 4 Wrigley; 5 Scott Guthrie (Crosle 25F); 6 Stuart. **CW** Wrigley. **FL** Gardner 1m44.301s (85.85mph). **S 21.**

CADWELL PARK
VSCC, JUNE 7



JOHN HOLLAND TROPHY FOR VINTAGE RACING CARS & SHUTTLEWORTH, NUFFIELD AND LEN THOMPSON MEMORIAL TROPHIES FOR PRE-1961 RACING CARS (12 LAPS) 1 Mark Gillies (ERA R3A) 21m46.95s (72.30mph); 2 Fred Harper (Kurtis Indy Roadster) +21.94s; 3 Clive Wilson (Cooper T43); 4 Nick Topliss (ERA R4A); 5 Ben Fidler (ERA AJM1); 6 Tom Walker (Amilcar-Hispano Special).

CW Walker. **FL** Gillies 1m47.16s (73.48mph). **P** Gillies. **S 18. GARRY WHYTE TROPHY HANDICAP RACE FOR RILEY PRE-WAR RACING AND SPORTS-CARS (5 LAPS) 1 Nick Hayward-Cook (9 Monoposto) 11m43.05s (59.38mph);** 2 John Collins (Brooklands) +6.06s; 3 Simon Kelleway (Sprite 12/4); 4 James Potter (Brooklands); 5 William Elbourn (12/4 Spl); 6 Simon Stokes (Treen). **FL** Stokes 2m00.76s (65.21mph). **S 17.**

GEOGHEGAN TROPHY RACE FOR STANDARD & MODIFIED PRE-WAR SPORTS-CARS (6 LAPS) 1 William Mahany (HRG Le Mans Model) 12m17.55s (64.06mph); 2 Andrew Mitchell (HRG 1 1/2-litre); 3 Mark Brett (Ballamy-Ford LMB V8 Spl); 4 Jo Blakeney-Edwards (Frazer Nash Super Sports); 5 James Potter (Riley Brooklands); 6 David Johnson (Frazer Nash Colmore). **FL** Mahany 2m00.41s (65.40mph). **P** Mahany. **S 23.**

MELVILLE TROPHY RACE FOR SPECIAL PRE-WAR SPORTS-CARS (6 LAPS) 1 Richard Iliffe (Riley Kestrel 12/4 Sprite) 12m30.20s (62.98mph); 2 David Pryke (Riley 12/4 TT Sprite Rep) +0.68s; 3 Charles Jones (MG L Magna); 4 Bill Cleyndert (Wolseley Hornet Spl); 5 Christopher Batty (FN Super Sports); 6 William Hildyard (FN Super Sports). **FL** Pryke 2m02.07s (64.51mph). **P** Brian White (FN/BMW TT Replica). **S 14.**



Gormley's F3 won from Hancock in FF2000

ROUND-UP



Mahany hustles his HRG LM to victory

SPERO & VOITURETTE TROPHY RACE FOR PRE-WAR CARS UP TO 1100CC (7 LAPS) 1 William Mahany (HRG Le Mans Model) 13m57.18s (65.84mph); 2 Christian Pedersen (Austin 7 Monoposto) +7.82s; 3 Harry Painter (MG Kayne); 4 Nick Hayward-Cook (A7 Monoposto); 5 Mark Elder (A7 Sports Spl); 6 Tom Waterfield (A7 Spl). **FL** Mahany 1m56.63s (67.52mph). **P** Mahany. **S** 17.

FRAZER NASH & GN CARS (7 LAPS) 1 Charles Gillett (Fraser Nash Super Sports) 13m26.14s (68.38mph); 2 Robert Carr (AC/GN Spl) +6.72s; 3 Tony Lees (AC/GN Cognac Spl); 4 Julian Grimwade (FN Norris Spl); 5 Brian White (FN/BMW TT Replica); 6 Alex Peacock (FN AC). **FL** Gillett 1m52.35s (70.09mph). **P** Gillett. **S** 22.

MORGAN THREE-WHEELER CHALLENGE (5 LAPS) 1 Hamish Bibby/Bill Tuer (JAP 8/80 Racing) 10m20.07s (63.50mph); 2 Charles Reynolds/Steve Ash (JAP Super Sports) +5.42s; 3 Greg Bibby/Maggie Tuer (JAP 8/80 Racing); 4 Nigel & Sarah Challis (JAP 8/80 Super Sports); 5 Pete Clews/Becky Washington (Super 100E OHV); 6 Graham Sherwood/Phil Bridge (M3W S8S). **CW** Sherwood/Bridge; Danny Hodgson/Bronte Pearson (F2 E93A). **FL** H Bibby/B Tuer 1m58.90s (66.23mph). **P** H Bibby/B Tuer. **S** 12.

PRE-WAR HANDICAP RACE (5 LAPS) 1 Bill Cleynrd (Wolsley Hornet Spl) 11m15.43s (59.61mph); 2 Richard Lake (Aston Martin 15/98 Speed Model) +3.02s; 3 Andrew Kellock (Fiat AC); 4 Jeffrey Edwards (Alvis Sports Spl); 5 Mark Brett (Ballamy-Ford LMB V8 Spl); 6 Mike Painter (MG Kayne). **FL** Christian Petersen (Austin 7 Monoposto) 2m02.43s (64.32mph). **S** 16.

PRE-WAR HANDICAP RACE (5 LAPS) 1 Simon Kelleway (Riley Sprite 12/4) 11m56.80s (59.49mph); 2 Philip Bewley (Bugatti T35) +10.75s; 3 Michael New (Riley 12/4); 4 Dennis Bingham (Riley Falcon Spl); 5 Roland Woodliff (Riley 15/6 Spl); 6 Egon Fertig (Bumbershoot BK43 Spl). **FL** Kelleway 2m08.39s (61.33mph). **S** 19.

PRE-WAR SCRATCH RACE (6 LAPS) 1 Mark Gillies (ERA R3A) 11m00.75s (71.50mph); 2 Nick Topless (ERA R4A) +41.95s; 3 Julian Grimwade (FN Norris Spl); 4 Tim Greenhill (Wolsley Hornet Spl); 5 Pete Candy (Riley 'Super Rat'); 6 Alex Peacock (FN AC). **CW** Grimwade; Candy; Hugh Birley (Austin 7 Ulster). **FL** Gillies 1m46.85s (73.69mph). **P** Gillies. **S** 14.

SILVERSTONE

BRSCC, JUNE 6-7



RADICAL EUROPEAN MASTERS (24 LAPS) 1 Terrence Woodward/Ross Kaiser (Radical SR8) 50m02.099s (105.349mph); 2 Jamie Patterson/Alex Kapadia (Radical SR8) +0.944s; 3 Chris Hyman/Alex Mortimer (Radical SR8); 4 Alain Costa (Radical SR8); 5 Chris Hoy (Radical Spyder); 6 Ozzy Yusuf (Radical SR8). **CW** Peter Belshaw/Phil Keen (Radical SR3 RSX). **FL** Kaiser 1m58.857s (110.871mph). **P** Patterson/Kapadia. **S** 22.

RACE 2 (22 LAPS) 1 Woodward/Kaiser 52m02.813s (92.837mph); 2 Patterson/Kapadia +6.479s; 3 Jon Harrison/Victor Correa (Radical SR8); 4 Hyman/Mortimer; 5 Yusuf; 6 Costa. **CW** Marcelo Marateotto/Marco Cencetti (Radical SR3 RSX). **FL** Kaiser 1m59.369s (110.395mph). **P** Woodward/Kaiser. **S** 22.

SEAT LEON EUROCOUP (11 LAPS) 1 Stian Paulsen 24m43.965s (97.681mph); 2 Pol Rosell +0.576s; 3 Mikael Azcona; 4 Alex Morgan; 5 Manuel Gao; 6 Jordi Oriola. **FL** Azcona 2m13.066s (99.032mph). **P** Paulsen. **S** 28.

RACE 2 (11 LAPS) 1 Jonathan Cocker 24m49.070s (97.346mph); 2 Morgan +1.342s; 3 Oriola; 4 Julien Briche; 5 Paulsen; 6 Azcona. **FL** Briche 2m13.909s (98.409mph). **P** Cocker. **S** 28.

EUROFORMULA OPEN (15 LAPS) 1 Yu Kanamaru 29m09.420s (112.990mph); 2 Vitor Baptista +0.723s; 3 Alessio Rovera; 4 Yarin Stern; 5 Diego Menchaca; 6 Damiano Fioravanti. **CW** Rovera. **FL** Baptista 1m55.549s (114.045mph). **P** Baptista. **S** 17.

RACE 2 (15 LAPS) 1 Konstantin Tereshchenko 29m07.822s (113.093mph); 2 Kanamaru +0.766s; 3 Baptista; 4 Leonardo Pulcini; 5 Rovera; 6 Tanart Sathienthirakul. **CW** Pulcini. **FL** Tereshchenko 1m55.271s (114.320mph). **P** Kanamaru. **S** 17.

INTERNATIONAL GT OPEN (34 LAPS) 1 Alvaro Parente/Miguel Ramos (McLaren 650S GT3) 1h11m06.628s



Parente and Ramos took GT Open victory

(105.012mph); 2 Alessandro Balzan/Nicola Benucci (Ferrari 458 Italia GT3) +3.065s; 3 Pasin Lathouras/Michele Rugolo (Ferrari); 4 Ezequiel Perez Compagn/Raffaele Giammaria (Ferrari); 5 Shaun Balfe/Phil Keen (Ferrari 458); 6 Emiliano Lopez/Matias Russo (Ferrari). **CW** Felipe Barreiros/Mads Rasmussen (Ferrari). **FL** Rugolo 2m01.281s (108.655mph). **P** Ramos/Parente. **S** 12.

RACE 2 (29 LAPS) 1 Perez Compagn/Giammaria 1h00m29.591s (105.278mph); 2 Balfe/Keen +5.187s; 3 Balzan/Benucci; 4 Lopez/Russo; 5 Ramos/Parente; 6 Lathouras/Rugolo. **CW** Barreiros/Rasmussen. **FL** Parente 2m00.364s (109.483mph). **P** Balfe/Keen. **S** 11.

RADICAL SR1 CUP (9 LAPS) 1 Chris Rees 21m00.711s (94.074mph); 2 Mark Richards +0.257s; 3 Rob Watkins; 4 Dave Morgan; 5 Kye Wheatley; 6 Lewis Gee. **FL** Watkins 2m18.353s (95.248mph). **P** Morgan. **S** 15.

RACE 2 (9 LAPS) 1 Watkins 21m03.407s (93.873mph); 2 Rees +1.131s; 3 Morgan; 4 Gee; 5 Richards; 6 Mark Tishwah. **FL** Richards 2m17.946s (95.528mph). **P** Watkins. **S** 14.

RADICAL ENDURO (42 LAPS) 1 Peter Belshaw/Phil Keen (SR3 RSX) 1h30m59.054s (102.917mph); 2 Grahamie Tilley/Rob Bell (SR3) +0.891s; 3 Harry Cockill/Ed Cockill (SR3 RSX); 4 Steve Burgess (SR3); 5 Shahin Nouri (SR3 RSX); 6 David Lidbetter/Scott Mansell (SR3 RSX). **CW** Chris Hoy (Spyder). **FL** Alex Mortimer 2m01.614s (109.995mph). **P** Chris Hyman/Mortimer. **S** 15.

MONDELLO PARK

MEC, JUNE 6-7



HRCA HISTORICS (8 LAPS) 1 Val Thompson (TMC Costin) 16m00.035s (65.30mph); 2 Steve Griffin (MG Midget) +0.840s; 3 Michael Doyle (Lotus Elan); 4 Paul Gray (Porsche 911RS); 5 Mark Russell (Jaguar XJS); 6 Matt Dunne (MG Midget). **CW** Griffin; Liam Ruth (MG Midget). **FL** Doyle 1m58.712s (66.01mph). **P** Griffin. **S** 15.

RACE 2 (7 LAPS) 1 Griffin 14m16.078s (64.07mph); 2 P Des Foley; 3 Will Corry (Austin-Healey Sebring Sprite); 4 Doyle; 5 Russell; 6 Ruth. **CW** Gray; Ruth. **FL** Griffin 1m59.920s (65.34mph). **P** Griffin. **S** 11.

FORMULA VEE QUALIFYING RACE (8 LAPS) 1 Anthony Cross (Sheane) 15m49.413s (66.03mph); 2 Paula Moore (Leastone) +7.289s; 3 Mark Elliott (Sheane); 4 Gavin Buckley (Sheane); 5 Damian Murphy (Leastone); 6 James Jones (Sheane). **FL** Moore 1m57.010s (66.97mph). **P** Des Foley (Leastone). **S** 13.

FINAL (8 LAPS) 1 Ray Moore (Leastone) 16m26.977s (63.52mph); 2 Dan Polley (Sheane) +0.241s; 3 Jimmy Furlong (Sheane); 4 David Kelly (Sheane); 5 Foley; 6 Colm Blackburn (Leastone). **FL** Furlong 1m54.944s (68.17mph). **P** Moore. **S** 20.

AUTO CARE FORMULA SHEANE (9 LAPS) 1 Enda O'Connor 16m27.276s (71.433mph); 2 Brian Hearty +4.678s; 3 Keith Hogg; 4 David Parks; 5 Kevin Sheane Jr; 6 Richard Kearney. **FL** Hearty 1m48.731s (72.07mph). **P** O'Connor. **S** 16.



Niall Quinn was a class winner in ITCC

15m39.366s (66.73mph); 2 Parks +1.305s; 3 Sheane; 4 Hogg; 5 Hearty; 6 Kearney. **FL** O'Connor 1m48.265s (72.38mph). **P** O'Connor. **S** 16.

IRISH TOURING CARS (8 LAPS) 1 Eoghan Fogarty (BMW M3) 15m23.890s (67.85mph); 2 Robert Savage (Honda Integra) +0.612s; 3 Garrett Hayden (Honda Integra); 4 Kevin Doran (Honda Civic); 5 Owain Drought (Honda Integra); 6 Shane Rabbitt (Mazda RX7). **CW** Stephen Dunne (Toyota Corolla); Niall Quinn (SEAT Leon Supercopa). **FL** Savage 1m53.433s (69.08mph). **P** Doran. **S** 24.

RACE 2 (8 LAPS) 1 Eric Carroll (Honda Integra) 15m35.358s (67.02mph); 2 Savage +1.472s; 3 Hayden; 4 Rabbitt; 5 Drought; 6 Jason Hughes (Honda Integra). **CW** Ian O'Driscoll (Honda Civic); Michael Cullen (SEAT Leon Supercopa). **FL** Savage 1m54.375s (68.51mph). **P** Hughes. **S** 20.

FUTURE CLASSICS (7 LAPS) 1 Robbie Parks (Toyota Celica) 15m30.172s (58.97mph); 2 Ian Thornton (VW Golf) +0.853s; 3 Aidan Byrne (Fiat Punto); 4 David Hammond (Fiat Uno); 5 Eoghan O'Brien (Fiat Punto); 6 Sophie Byrne (Ford Fiesta XR2). **FL** Daniel Byrne (Vauxhall Chevette) 2m07.995s (61.22mph). **P** D Byrne. **S** 19.

MONDELLO PARK GT SERIES/ASK SUPERCARS (8 LAPS) 1 Sean Doyle (RT Supercar) 15m19.456s (68.18mph); 2 Peter Barrable (RT Supercar) +1.015s; 3 Bob Cameron (RT Supercar); 4 Pat McBenett (Lotus Elise); 5 Phillip Jones (RT Supercar); 6 Graeme Colfer (RT Supercar). **CW** McBenett. **FL** McBenett 1m49.176s (71.77mph). **P** Barrable. **S** 11.

RACE 2 (8 LAPS) 1 Barrable 15m27.048s (67.62mph); 2 Cameron +17.469s; 3 Jones; 4 John Cardoo; 5 Noel Collins; 6 Vincent O'Reilly. **FL** McBenett 1m49.162s (71.78mph). **P** Doyle. **S** 11.

BAKER AUTOMOTIVE STRYKERS (8 LAPS) 1 Alan Auerbach 15m18.930s (68.22mph); 2 Alan Watkins +1.855s; 3 Dave Griffin; 4 Greg Kelly; 5 Mark Baker; 6 Des Meehan. **FL** Auerbach 1m53.710s (68.91mph). **CLASS RECORD.** P Auerbach. **S** 12.

BLACKCHURCH MOTORS FIESTA QUALIFYING RACE (7 LAPS) 1 Colm Barrable 15m45.094s (58.04mph); 2 Keith Dawson +0.265s; 3 Barry Barrable; 4 John Denning; 5 Ullick Burke; 6 Mark O'Donoghue. **FL** C Barrable 2m13.711s (58.60mph). **P** Dawson. **S** 28.

FINAL ONE (7 LAPS) 1 Barry Rabbitt 15m38.306s (58.46mph); 2 Brendan Fitzgerald +0.330s; 3 Michael Fitzgerald; 4 C Barrable; 5 Denning; 6 Daniel McDonnell. **FL** B Fitzgerald 2m12.880s (58.97mph). **CLASS RECORD.** P B Fitzgerald. **S** 30.

QUALIFYING RACE 2 (7 LAPS) 1 Dawson 11m13.745s (58.15mph); 2 Philip Lawless +0.983s; 3 C Barrable; 4 B Barrable; 5 Burke; 6 Denning. **FL** C Barrable 2m12.864s (58.98mph). **CLASS RECORD.** P Dawson. **S** 27.

FINAL TWO (6 LAPS) 1 B Fitzgerald 14m04.954s (55.64mph); 2 Rabbitt +1.584s; 3 Stephen Kirwan; 4 M Fitzgerald; 5 B Barrable; 6 C Barrable. **FL** B Fitzgerald 2m12.464s (59.16mph). **CLASS RECORD.** P Rabbitt. **S** 32

SHELSLEY WALSH

MAC, JUNE 6-7



ROUND 9 1 Jos Goodyear (1.3s GWR-Suzuki Raptor 2) 23.09s; 2 Scott Moran (3.5 Gould-NME GR61X) 23.23s; 3 Alex Summers (3.5 Gould-NME GR61X) 23.30s; 4 Will Hall (2.0 Force-AER/XTec WH) 23.84s; 5 Tom New (3.5 Gould-NME GR55) 24.04s; 6 Alastair Crawford (2.8 Gould-NME GR55) 24.17s; 7 Wallace Menzies (3.5 Gould-NME GR55) 24.26s; 8 Dave Uren (1.3t Force-Suzuki PC) 24.27s; 9 John Bradburn (3.5 Gould-Cosworth GR55) 24.67s; 10 Paul Haines (1.3t Gould-Suzuki GR59) 25.06s; 11 Ed Hollier (1.6 Empire-Suzuki 00 Evo) 26.06s; DNF Trevor Willis (3.2 OMS-RPE 28).

ROUND 10 1 Moran 23.20s; 2 Summers 23.42s; 3 Willis 23.68s; 4 New 23.76s; 5 Goodyear 23.93s; 6 Menzies 24.12s; 7 Bradburn 24.43s; 8 Crawford 24.58s; 9 Haines 25.14s; 10 Eynon Price (1.6 Gould-Suzuki GR59) 25.97s; DNF Uren; DNS Hall.

CLASSES David Finlay (1.5t BMW i8 Hybrid) 35.27s ESTABLISHES ELECTRIC/HYBRID RECORD; Paul De Ville (2.0 Tiger S6) 40.72s; Paul Jones (1.8 Lotus Elise 135R) 34.31s; Tony Bunker (3.8t Nissan GT-R) 32.64s; Allan Warburton (2.5 Caterham-Duratec) 29.87s; Carlton Jones (1.4 Austin Mini-Cooper 16v) 34.09s; Colin Satchell (2.0 Peugeot 205) 32.11s; Mike Turpin (2.2s Vauxhall VX220) 30.12s; Charles Williams (OMS-Honda SC1) 31.14s; Rob Stevens (1.44s Force-Suzuki SR4) 26.18s; Chris Aspinall (1.0 Empire-Suzuki Wraith) 26.72s; Ben Tranter (1.6 Vector TF93K FF) 31.89s. **RECORD.** Hollier 25.68s; Howard Savage-Jones (2.0 Lola-TKD Colgan) 27.59s; Goodyear 23.03s BTD; Summers 23.48s.

CHAMPIONSHIP POSITIONS AFTER ROUND 10 1 Summers 87; 2 Moran 77; 3 Willis 66; 4 Hall 53; 5 Menzies 46; 6 Goodyear 41; 7 Crawford 40; 8 New 38; 9 Bradburn 23; 10 Haines 19.



GT heaven in

The ninth AUTOSPORT 3 Hours retrospective is held at Snetterton this weekend. [MARCUS PYE](#)

It's as iconic a confrontation as Ford versus Ferrari: Jaguar and Austin-Healey go head to head in a 1960s scrap to savour at Snetterton on Saturday. The ninth HSCC AUTOSPORT 3 Hours retrospective – again using an all-GT format following last year's experiment – outnumbers the eight contemporary events of '57-'64, and has attracted another strong entry. Courtesy of Jeremy Welch and his client Julian Thomas, last year's second-placed Healey 3000 and an E-type provided another perspective on the action this coming Saturday.

Conceived a dozen miles apart in England's heartland – Jaguar's E-type in industrial Coventry and Donald Healey's 3000 in historic Warwick (although early Healeys



Jeremy Welch gives Pye some pointers

were built by Austin in Birmingham, hence the double-barrelled monicker, the 3000s were made at BMC's Abingdon plant) – the standard-setting models beloved

worldwide are strikingly similar in overview, yet refreshingly different. Both Grand Tourers used proven parts and demonstrated their mettle on race tracks. In the latter's case,

"The Healey's a strong car, and the engine's pretty unburstable"

Jeremy Welch

on gruelling rallies too.

Let me introduce the two protagonists. In the red corner is the Austin-Healey: square-jawed, stockily-built and with the stance of a fighting dog. A glint in its eyes and smiling mouth bely its snarl as its opponent approaches. Slinking into the blue (OK, silver) corner is the Jaguar, unmistakably feline with the rear musculature of a rampant big cat. This is going to be some confrontation, for the 3000 and

AUTOSPORT 3 HOURS TIMETABLE

SATURDAY JUNE 13		SUNDAY JUNE 14	
0900-0930	Testing	0900-1120	Qualifying
1030-1115	Qualifying	1135-1355	Races 6-8
1130-1225	Races 1-2	1410-1440	ARCHIE SCOTT BROWN TROPHY
1400-1700	AUTOSPORT 3 HOURS	1455-1745	Races 10-14
1715-1810	Races 4-5		



85

East Anglia

samples two of the iconic machines that will star in Saturday's centrepiece event

E-type models' CVs are both valiantly impressive.

Each packs a straight-six punch. The Healey's engine is a three-litre single-cam overhead valve (OHV) workhorse, its iron cylinder block sourced from Austin's big Westminster saloon and topped by an aluminium head, breathing through triple Weber DCOE carburettors, like the E-type's. The 3.8-litre Jaguar XK powerplant, which excited on its debut in 1948, is a twin overhead cam unit which, in this pure competition instance, uses the homologated aluminium block and wide-angle head housing larger valves for enhanced gas flow.

Both left impressions on me as a lad in 1967. Having watched, enthralled, as John Chatham and

Stewart Hands grappled in big Healeys at a gruesomely soggy Castle Combe, my previous sampler in one was as a passenger in Chris Clarkson's racer at 2014's Autumn Classic launch.

Also 48 years ago, the contrasting Jags of arch-rivals John Quick and Warren Pearce coloured my earliest E-type memories. A couple of very ginger laps at a frantically busy Donington in Andy Jenkinson's lightweight evocation in 2007 provided no driving clues.

Now I would gain proper insight. Immaculately prepared, the cars sat in echelon before the Denis Welch Motorsport truck in Snetterton's paddock. With rain en route, I wanted to get started. The Healey – in which Jeremy and his late father finished a sensational ▶



Disc-equipped cars 'dance' when pushed

ALL PICS: HOYER/EBREY



Base Performance SIMULATORS

Driver development simulators for single seater and GT racing

HIRE | EVENTS | SALES

Manor Park, Warkworth, Banbury, OX17 2AG

www.baseperformance.net
+44 (0) 1295 276611

info@baseperformance.net
[@BaseSimulators](https://www.instagram.com/BaseSimulators)



► second (to a pro-driven lightweight-spec E-type) last year, ‘won’ the toss. My first shot in a racing car since 2012 would also be my baptism on the full circuit, previously explored only in an MSV BMW M3 road car.

Heart thumping, I twisted the red ignition master key and, with fuel-pump switch flicked down and carbs primed by a couple of squirts from the right-hand pedal, prodded the starter button. “Use 7000rpm, the engine likes seven,” said Jeremy before the engine caught, having instructed me to use the clutch to engage overdrive – essentially an electromechanically triggered longer gear, operable in third and fourth, switched to the right of the upright steering wheel. New to me, it would

be interesting to see the revs drop down the Senna Straight.

I liked the Healey’s straight-backed seating position which, with a high eye line and relatively short nose, helped me position it accurately in the corners, keeping away from kerbs, which can hook the unwary into the infield barriers or damage the underpinnings or driveline. Worm-and-peg steering naturally doesn’t feel quite as pin-sharp as rack-and-pinion (per the Jag) during low-speed cornering, when it’s relatively heavy, not that aces like Welch notice. They use ‘power assistance’ (hefty foot on loud pedal), whereupon the pendulous live-axled tail is checked by a ZF-plated limited-slip differential.

Kept on song – anything above

4000-4500rpm when the Webers stop spitting and the torquey engine climbs onto the cam – it pulls heartily with a fierce rasp. When revved fully, urgent acceleration is felt down the two long straights and momentum is maintained into the braking areas with the overdrive facility. Towards the end of my run, when au fait with the circuit and pushing a little harder, I could feel the back end dancing, as Jeremy explained disc-braked Healeys do. Drummers are not prone to this, apparently, but it’s all comfortable and controllable, reminiscent of locking the rear wheel of a bicycle and sliding it.

Once a bit of momentum is carried through the twisty Agostini-Hamilton-Oggies-Williams sequence of corners it becomes great fun on treaded tyres. Because the compact Healey likes to change direction with keen throttle response it’s a wieldy tool, so it’s easy to understand how it bats above its weight when enterprisingly driven in historic endurance races.

“It’s a strong car and the engine’s pretty unburstable, but it comes into its own when it’s wet,” grins Welch. “That’s why Dad and I got the memorable result last year. Healeys used to finish well up in the Spa Six Hours too, but there are so many Ford GT40s now that the days of finishing in the top 10 are long gone. Although I’ve not driven a Chevron, stopping them from competing in the Snetterton race has made it a more level playing field, which can be seen from the entries.”



DENIS WELCH RACING

Yoxall, near Burton-on-Trent in Staffordshire, has long been the hub of the universe for big Healey racers and connoisseurs, for it is from here that the Denis Welch Racing emporium has built its reputation as a world leader in the development and preparation of the 3000 in particular.

Run for the past decade by Jeremy Welch, DWR is dedicated to furthering the work of his late father Denis (1944-2014), whose spectacular sideways driving style in gruff Healeys fully demonstrated their capabilities, endearing him to rivals and spectators.

“Dad was brilliant in a car, but he drove with pure talent rather than an engineering mind,” says Welch Jr. “I was fortunate to discover engineering at school, so focus on the cars we prepare, the engines we build and the vast range of parts we make from a different direction. We have a fully equipped machine shop in-house and employ CAD designers to make the best quality components we can.

“Although renowned as Healey specialists, we also do a huge amount of Jaguar business. While building my E-type we soon realised that we couldn’t buy the parts we needed, so we made it another speciality. DWR currently stocks 250,000 items [£1.1m-worth, from FIA-approved Healey cylinder heads to Jaguar wheels] in what has become a one-stop shop supplying mail-order customers worldwide.”

For the next session, under darkening skies, the E-type beckoned seductively. Racelogic boss Julian Thomas’s car was built to FIA-homologated specification by the DWR team last year. Unlike the 1950s-rooted Healey, whose bodysheath straddles a steel girder chassis, the Jaguar boasts a unitary monocoque centre section – in 5303 VB’s case, the lighter alloy option rather than the road-spec steel – evolved from the triple Le Mans-winning D-type, with a tubular steel subframe carrying the engine.

The most striking body derivative in period competition was the ultra-svelte ‘low-drag coupe’, which this example mirrors, characterised by lines of perfectly spaced rivet heads across its roof and wings. ►

THE RACING HEALEYS & E-TYPES

Introduced in 1959 – by which time Austin-Healey marque’s greatest racing successes had been achieved with the 100M, 100/6 and its fabulous 100S models – the 3000 was outgunned on the biggest racing stages but found its metier in international rallies. Despite their strength on mixed surfaces, and in club events, no 3000s finished at Le Mans, but skill and perseverance brought a class win for Paul Hawkins/Warwick Banks (who finished behind the best-placed Sprite, which proved a giant-killer in top hands) in the wet ‘65 Sebring 12 Hours.

Jaguar’s racing record with its E-type ran in parallel with Healey’s, as its glory days with C- and D-types were not to be repeated. Enzo Ferrari’s V12 GTOs were more powerful, but Briggs Cunningham/Roy Salvadori and Peter Lumsden/Peter Sargent finished fourth and fifth at Le Mans in ‘62. The lightweight Es arrived too late to reverse a trend, but series production-based models dominated Marque Sports (and later Modsports) races through the 1970s. Like the big Healeys, though, their striking presence lives on in historic racing, in unprecedented numbers.



**ULTIMATE DRIVING
AT GOODWOOD**
powered by BMW

THE UK'S NEWEST DRIVING EXPERIENCE



4x4 OFF ROAD
PERFORMANCE TRACK
GOODWOOD ACADEMY



Telephone: 01243 216611
Email: circuit@goodwood.com
Visit: www.goodwood.com/drive



Rain stopped play, but not enjoyment



Jag's driving position snug but perfect

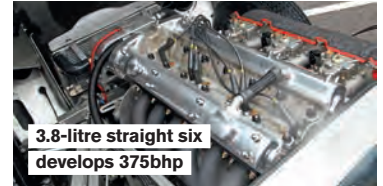

3.8-litre straight six develops 375bhp



Light internals mean E-type starts quickly

► Even more wind-cheating than uberstylist Malcolm Sayer's immortal original, it's taller than the legendary genuine lightweights (the 'last' six of which, unbuilt in 1963, are now being crafted by Jaguar and sold for seven-figure tags), with a more bulbous roof and flared tail. The 'low-drag' has huge presence from any angle. Squatting aggressively on its haunches, ready to pounce on and savage its prey, it doesn't look any different on track.

Although there is a little more cockpit room than in the Healey, the body-hugging single-seater seat – which Fun Cup graduate Thomas and mentor/team-mate Nigel Greensall prefer – makes access and egress trickier. Once behind the wheel, however, the ergonomics were nigh-on perfect for me too. Starting the engine is a similar ritual, but with lighter internals the XK spins up quickly. I'm instructed to use 6000rpm and, even with the

customary throttle blip to shepherd a lower gear in, not to change down too quickly or too early because that's the easiest way to overrev the engine and risk damaging the 'box. With the circuit now an engaging melange of fast and technical sections I was up to a pace sooner, the Jag's agile handling and usable power inspiring immediate confidence. With around 375bhp on tap from its 3.8-litre engine (about 100bhp more than the Healey's smaller 'six pack') and homologated by Jaguar to run 113kg lighter at 920kg, the E-type accelerates very briskly with an encouraging exhaust howl and less audible induction noise. Using the same gears to negotiate the 11-corner, three-mile circuit, and with a slicker downchange making second an easy choice for Agostini, I was getting going when rainspots hit the screen with increasing regularity. Whereas the Jaguar's longer wheelbase telegraphed the independently-sprung chassis'

intentions well through Riches and the Brundle/Nelson complex, the live-axled Healey wanted to be thrown at corners like Hamilton and Williams and steered on the gas. That might have taken me a couple more stints to really enjoy, but I declined Jeremy's kind offer of another go in the wet after our torrential tracking lap, arranged in the lunchbreak by Snetterton's ever-obliging management. What I did notice in the smooth-riding Jag was that harder exits from Williams brought results. We were approaching the Esses at 5800rpm (almost 140mph, Julian noted) towards the end of my run, where the brakes were shaving speed off straight and true, albeit with a little less feel than those of the Healey. It's not power or retardation but the consistency of grip levels over a three-hour race – the cars are on the same Dunlop L-section tyres, wider on the Jag's peg-drive rims – that will determine the outcome. And a little help from the traffic! 🏎️



Agile Jaguar E-type confidence-inspiring

2015 AUTOSPORT 3 HOURS

2015 HSCC/GTSCC AUTOSPORT 3 HOURS, for Pre-1966 GT and Pre-1963 Sports Racing Cars

AUSTIN-HEALEY 3000 Jeremy Welch/Mark Pangborn; Chris Chiles; Chris Chiles Jr/Paul Ingram; Chris Clarkson/David Smithies.
JAGUAR E-TYPE Julian Thomas/Nigel Greensall; Martin O'Connell/Andrew Kirkaldy; John Clark/TBC; Klaus Bergs/James Denty; Read Gomm/Andy



Kirkaldy: in E-type

Keith-Lucas; John Burton/Rob Newall; Simon Butler/Martin Rich/Jon Crouch.
JAGUAR XK120 Christopher Scholey/Nick Finburgh.
LOTUS ELAN Mark Halstead/Stuart McPherson; John Davison/Ed Morris; Martin Eyears/Joe Twyman/Gregor Fiskien; Will Goff/Michael Goff; Mark Midgley/Simon Drinkall/

Tony Worthington; Andrew Garside/Andy Newall.
MGB Beverley Phillips/Chris Phillips/Oliver Phillips; Brian Lambert/Barbara Lambert.
TVR GRANTURA MKIII Malcolm Paul/Rick Bourne; Joe Ward/Richard Bull.
MORGAN +4 SLR Simon Orebi Gann/Calum Lockie.
TRIUMPH TR4 Allan Ross-Jones/Daniel Ross-Jones.
PORSCHE 356 Steve Wright/Ian Clark/Nick Fulljames.
SHELBY MUSTANG GT350 Nick Sleep/Bill Wykeham/Joel Wykeham.
COOPER T39 BOBTAIL Adrian van der Kroft/TBC.
LISTER-JAGUAR Barry Wood/Tony Wood/Alasdair McCaig.



Lockie: Morgan

CONTEMPORARY WINNERS

- 1957 Ken RUDD (AC Ace-Bristol)
- 1958 John LAWRIE (Lotus Elite)
- 1959 Jim CLARK (Lotus Elite)
- 1960 Dickie STOOP (Porsche 356B)
- 1961 Mike SALMON (Jaguar D-type)
- 1962 Mike PARKES (Ferrari 250 GT0)
- 1963 Jim CLARK (Lotus 23B)
- 1964 Jack SEARS (Willment Cobra Coupe)

HISTORIC WINNERS

- 2007 Simon HADFIELD/Michael SCHRYVER (Chevron B6)
- 2008 Simon HADFIELD/Michael SCHRYVER (Chevron B6)
- 2009 James & Jeremy COTTINGHAM (Chevron B8)
- 2010 Alex AMES/Gareth BURNETT (Chevron B8)
- 2011 Nick FLEMING/Luke STEVENS (Chevron B8)
- 2012 Nick FLEMING (Chevron B8)
- 2013 Nick FLEMING (Chevron B8)
- 2014 Chris WARD/Alex BUNCOMBE (Jaguar E-type)



Teddington Studios, Broom Road, Teddington, Middlesex TW11 9BE, UK.
Tel: +44 (0) 20 8267 5804 Fax: +44 (0) 20 8267 5922
E-mail: autosport@haymarket.com Website: www.autosport.com

EDITOR
Edd Straw ext.5889
edd.straw@haymarket.com

DEPUTY EDITOR
Marcus Simmons ext.5807
marcus.simmons@haymarket.com

CHIEF F1 CORRESPONDENT
Ian Parkes ext.5810
ian.parkes@haymarket.com

GRAND PRIX EDITOR
Ben Anderson ext.5425
ben.anderson@haymarket.com

F1 REPORTER
Lawrence Barretto ext.5887
lawrence.barretto@haymarket.com

FEATURES EDITOR
Scott Mitchell ext.5370
scott.mitchell@haymarket.com

EDITOR AUTOSPORT.COM
Glenn Freeman ext.5309
glenn.freeman@haymarket.com

DEPUTY EDITOR AUTOSPORT.COM
Matt Beer ext.5811
matt.beer@haymarket.com

INTERNATIONAL EDITOR
Mitchell Adam ext.5432
mitchell.adam@haymarket.com

MANAGING EDITOR
Peter Hodges ext.5903
peter.hodges@haymarket.com

EXECUTIVE EDITOR
Stuart Codling ext.5835
stuart.codling@haymarket.com

GROUP NATIONAL EDITOR
Rob Ladbroke ext.5209
robert.ladbroke@haymarket.com

RALLIES EDITOR
David Evans
david.evans@haymarket.com

ART EDITOR
Lynsey Row ext.5914
lynsey.row@haymarket.com

SENIOR DESIGNER
Michael Cavalli ext.5381
michael.cavalli@haymarket.com

PHOTOGRAPHS
LAT Photographic, XPB Images

GROUP PICTURE EDITOR
Peter Mills ext.5918
peter.mills@haymarket.com

TECHNICAL TEAM LEADER
Geoff Creighton
geoff.creighton@haymarket.com

AUTOSPORT.COM DEVELOPER
Tomasz Trznadel
tomasz.trznadel@haymarket.com

SENIOR DIGITAL DESIGNER
Amar Vijay
amar.vijay@haymarket.com

OFFICE MANAGER
Joanne Grove ext.5804
joanne.grove@haymarket.com

SPECIAL CONTRIBUTORS
Gary Watkins Mark Glendenning Alan Eldridge
Henry Hope-Frost Dieter Rencken
Marcus Pye Gary Anderson

CORRESPONDENTS

ARGENTINA
Tony Watson

AUSTRALIA
Phil Bragan

AUSTRIA
Gerhard Kuntschik

BELGIUM
Gordon McKay

BRAZIL
Lito Cavalcanti

FINLAND
Esa Ilhonen

GERMANY
Rene de Boer

GREECE
Dimitris Papadopoulos

ITALY
Roberto Chinchero

JAPAN
Hiro Takahashi, Len Clarke

NEW ZEALAND
Bernard Carpenter

RUSSIA
Gregory Golyshev

SPAIN
Raimon Duran

SWEDEN
Tiege Tornvall

USA
Jonathan Ingram,
David Phillips, Robin Miller,
Jeremy Shaw

UK & EIRE
Jack Benyon, Jonathan
Crawford, Dan Cross,
Kerry Dunlop, Tom
Errington, Leanne Fahy,
Paul Healy, Linda Keen, Alex
Kalinaukas, Mark Libbeter,
Stephen Lickorish, Marc
Orme, Graham Read, Hal
Ridge, Peter Scherer, Ian
Somman, Oliver Timson, Ian
Titchmarsh, Eddie Walder,
Richard Young

ADVERTISING
Tel: +44 (0) 20 8267 5389
Fax: +44 (0) 20 8267 5850
E-mail: autosport.ads@haymarket.com

CLASSIFIED ADVERTISING
James Hunter ext.5367
james.hunter@haymarket.com

DISPLAY ADVERTISING
Garry Lee Hoebeck ext.5376
garry.lee.hoebeck@haymarket.com

DISPLAY SALES MANAGER
Martin Lee ext.5389
martin.lee@haymarket.com

SALES MANAGER
Don Rupal ext.5244
don.rupal@haymarket.com

CLASSIFIED SALES MANAGER
Jonathan Whitehead ext.5908
jonathan.whitehead@haymarket.com

ONLINE ADVERTISING
Leah Minns ext.5846
leah.minns@haymarket.com

SUBSCRIPTIONS
UK 0844 8488817
OVERSEAS +44 (0)1795 592 974
EMAIL autosport@servicehelpline.co.uk

BACK ISSUES
Tel: 0844 8488817

DIRECT MARKETING EXECUTIVE
Katie Chanter ext.5622
katie.chanter@haymarket.com

LICENSING AND SYNDICATION
LICENSING DIRECTOR
Alistair Lewis

MANAGEMENT
GROUP DIRECTOR
Tim Bulley

GROUP PUBLISHER
Stuart Williams

GROUP EDITOR
Anthony Rowlinson

GROUP COMMERCIAL DIRECTOR
Ben Guyan

PUBLISHING MANAGER
Samantha Jemson

SPECIAL EVENTS MANAGER
Laura Coppin

DIGITAL SPECIAL PROJECT MANAGER
Simon Strang, ext. 5093
simon.strang@haymarket.com

DIGITAL PRODUCT MANAGER
Simon Grayson, ext. 5346
simon.grayson@haymarket.com

CIRCULATION TRADE ENQUIRIES
Frontline Ltd, Park House, 117 Park
Road, Peterborough, Cambs, PE21 2TS.
Tel: +44 (0) 1733 555161. Printed in
England by Wyndeham Peterborough Ltd.
ISSN 0269-946X. AUTOSPORT,
incorporating Autosport, is published
weekly by Haymarket Consumer Media,
Teddington Studios, Broom Road,
Teddington, TW11 9BE, UK.

EDITORIAL DIRECTOR
Mark Payton

CREATIVE DIRECTOR
Paul Hopkin

STRATEGY AND PLANNING DIRECTOR
Bob McDowell

PUBLISHING DIRECTOR
Patrick Fuller

MANAGING DIRECTOR
David Prasher

CHIEF EXECUTIVE
Kevin Costello

recycle
Haymarket is certified by BSI to environmental standard ISO14001

PEFC
PEFC 16-23-197
PEFC Certified
This product is from sustainably managed forests and controlled sources
www.pefc.co.uk

THIS WEEK

LETTERS • ON TRACK • TV PICKS • FROM THE WEB • AUTOSPORT.COM

Want to have your say on motorsport? Email autosport@haymarket.com



Canada spotlights F1's issues

I think there is no clearer indication of what is wrong with F1 than this year's Canadian GP. This race used to be one of my favourites – a track which always gave good racing as the layout minimised the effect on overtaking of cars not being able to follow each other through corners.

Unfortunately, DRS has rendered the race a complete bore: passes were usually far too easy, completed well before the braking zone, and must have offered the drivers as little satisfaction as the viewers. Factor in fuel saving and you have a recipe for boring races.

The frustrating thing is that the answers are readily known: the need for DRS could be obviated by addressing the root cause of

the aero issues, by reducing the complexity (sensitivity) of the front wing and increasing underbody downforce, coupled with increasing mechanical grip.

The fix for fuel saving is obvious too, without bringing in refuelling: keep the fuel flow meters (needed to control engine power) but scrap the tank capacity limit.

The ACO has proved with its LMP1 rules that it is possible to have an open chassis formula that allows good racing.

F1 needs to take an honest look at what can be done, rather than fiddling around with changes to the cars that will do nothing to improve the racing.

Paul Cole, Orsett, Essex

Come on FIA, get DRS

calibration right, and everyone remember it is *not* an overtaking aid. It's a Dirty-air Redress System. The point of the system is to give back to the following car the time lost while chasing through corners.

Work out the DRS zone lengths (or add more GPS detection logic to the system) so that the DRS switches off as the cars come side by side, ie it will switch off before the braking zone. The overtaking car will have to fight it out with his victim, as while his momentum will still give him an advantage, it will be a diminishing one. If he can't get past, then he was never going to if the cars had no wings on them.

You can then extend the DRS

detection limit from one second to two, or three or whatever is needed to help the cars deal with said dirty air and catch up – but not pass.

**Paul Irwin
Bexleyheath**

If I go to the Canadian GP next

year, do you think I could have Michael Douglas's ticket? It appeared that lunch was more interesting than the race.

**Richard Rowe
Wotton-under-Edge**

Yet again Jonathan Palmer has

shown himself as a true motorsport visionary (pun intended) with new, as

with the old, BRDC F4. Compare and contrast with the money grabbing, egocentric types who run F1.

**David King
Sunderland**

I wanted to take the opportunity

to sing the praises of all involved in the Marshal Taster Day I attended on May 31 at Donington. It was absolutely fantastic.

I've always been in awe of the job marshals do, and I urge anyone interested in motorsport to at least try it once. My BMMC membership is in the post, and I can't wait to do it again!

**Carolyn Doyle
Gateshead**

BIG NUMBER

10 Tracy Krohn and Nic Jonsson, who will share a Krohn Racing Ligier, will set a new record for Le Mans 24 Hours starts as team-mates this weekend

DID YOU KNOW?

Michigan International Speedway was owned by Roger Penske from 1972 until 1999, when it was bought by International Speedway Corporation



ABBOTT/LAT

WHAT'S ON TRACK IN THE UK

ROCKINGHAM BRSCC

June 13
The BRSCC races on the long sportscar circuit, with the Mazda MX-5 series leading the day's menu.

SILVERSTONE MSVR

June 13-14
The Grand Prix circuit hosts top single-make series the Mini Challenge and a variety of other championships.



BMW

STYLES



HILLCLIMB

WALDER

LOTON PARK BRITISH HILLCLIMB

June 13-14
The hotly-contested 2015 season of British Hillclimb will make a stop at the Shropshire hill – the series' third-longest.

THRUXTON BARC

June 13-14
The spectacular British Truck Racing Association headlines on the country's fastest circuit this weekend. In addition, the BARC host club offers a varied itinerary, from the Kumho BMWs and Renault Clios to Pickup Truck racing.

EVENT OF THE WEEK



AUTOSPORT
3 Hours action

STYLES

SNETTERTON HSCC

June 13-14
The AUTOSPORT 3 Hours pits Pre-'66 GT cars against each other in this recreation of a period classic at the Norfolk

venue. Organised by the Historic Sports Car Club, other races include Classic Racing Cars, Historic Touring Cars, a

combined race for '70s Roadsports, plus Historic Formula Fords and Classic Clubmans machines.

WHAT'S ON TRACK AROUND THE WORLD



LEMANS

XPBIMAGES



FREUROCUP



NASCAR

LEVIT/LAT

LE MANS 24 HOURS

World Endurance Championship
Rd 3/8
Le Mans, France
June 13-14
fiawec.com

RALLY ITALY SARDINIA

World Rally Championship
Rd 6/13
Alghero, Italy
June 11-14
wrc.com



LEVIT/LAT

INDY

INDY LIGHTS

Rd 6/10
Toronto, Ontario, Canada
June 13-14
indycar.com/RoadToIndy

FORMULA RENAULT 3.5

Rd 4/9
Hungaroring, Hungary
June 13-14
renaultsport.com

FORMULA RENAULT EURO CUP

Rd 3/7
Hungaroring, Hungary
June 13-14
renaultsport.com

NASCAR SPRINT CUP

Rd 15/36
Michigan, USA
June 14
nascar.com



WRC

INDYCAR SERIES

Rd 9/15
Toronto, Ontario, Canada
June 14
indycar.com

McKLEIN/DE

FROM THE SOFA

WHAT'S ON TELEVISION



Premier delivers UK NASCAR coverage

WILLIAMS/LAT

Premier proving doubters wrong

WHEN PREMIER SPORTS stepped up and took on the broadcasting rights for NASCAR in 2011, it was a difficult time for the sport in the UK. The constant chopping and changing of formats and often being relegated to highlights rather than live broadcasts left British fans with a bitter taste in the mouth.

But since then Premier has offered some continuity, with its latest deal set to run until 2017. The broadcasts – essentially the US networks' coverage in full – haven't been met with complete satisfaction, but elements of its approach are judged harshly by some viewers who perhaps don't appreciate the bigger picture.

The most controversial element is the handling of adverts. When the Americans go to a commercial break, Premier maintains a silent feed showing the leaders on track or onboard footage of one of the drivers.

This has been slammed as being boring, but I disagree. Not only do you get to see any incidents on track while the Americans are learning about Cheez-Its or Papa Johns, you also get a feel for the inside of a stock car and how hard the driver is working, especially at tracks like Darlington.

In those commercial breaks, former broadcaster Sky Sports would cut to Keith Huewen in the studio discussing

the strategies and stories behind the race with a panel of guests, something some fans have claimed to miss.

But why have a panel of people discussing what's going on 3000 miles away, when Fox or whichever US broadcaster is showing the race has well over 20 reporters and presenters in the paddock live?

Those pundits include Larry McReynolds, a former crew chief-turned-analyst who can relate how an eighth of a turn on a trackbar can affect the car, and four-time champion Darrell Waltrip.

NASCAR has grown in popularity in the UK since Premier took over, with the 'NASCAR Fans UK' group on Facebook – which Premier advertises between

coverage – started by founder Kevin Gravenell in January 2011. The group has 2623 members, which may not sound like a lot, but compared with the biggest UK IndyCar group's 530 it's ahead by a very substantial margin.

Gravenell reckons that the discussion on NASCAR, as an American sport, should be led by the host nation: "I like how Premier Sports uses the American feed. A British studio is not needed with the American broadcasters having their own studios. Who better to talk about NASCAR than the Americans? After all it is their sport."

The channel is also open to new routes within the NASCAR world, showing Xfinity and Camping World Truck Series races and highlights, and discusses its direction with the Facebook group to offer what its viewers are looking for.

Its flexibility and commitment to fans is demonstrated best during rain delays. As NASCAR can't run on ovals in the wet, races are sometimes delayed through the night or into the next day. Premier generally still shows the race live whenever it's rescheduled, something Sky would struggle to do with its live broadcasts and strict schedule.

Premier's coverage isn't perfect, but it's done a lot for NASCAR and its fans in this country. Don't be too quick to judge. *Jack Beynon*

"Who better to talk about NASCAR than the Americans?"



Mike Joy keeps pundits in check

TV pick of

Edited by Val Khorounzhiy



EBREY/LAT

LE MANS 24 HOURS - LIVE

Eurosport
Saturday 1345-Sunday 1415
Eurosport's admirable commitment to the world's greatest endurance race continues as it shows all 24 hours live – mostly on its main channel with just a couple of brief Eurosport 2 diversions. Audi has not lost the event since 2009 and responded to its World Endurance Championship defeat by winning this year's first two rounds, though it will need to work hard to keep the Porsches at bay. Reigning WEC champion Toyota faces a harder week, as does Nissan as its radical prototype makes its debut.



LEWITT/LAT

INDYCAR - LIVE

BT Sport 2
Sunday 2000-2300
After the Texas oval, IndyCar heads back to the streets and visits Toronto for its only non-US round of 2015. James Hinchcliffe is the championship's only Canadian regular these days and he's out injured, with Conor Daly standing in. Street circuits breed odd results: title rivals Juan Pablo Montoya, Will Power, Scott Dixon and Helio Castroneves all failed to make the podium across the Detroit double-header, where 2014 Toronto victor Sebastien Bourdais was a winner again (along with, more surprisingly, Carlos Munoz).

GET AUTOSPORT ON THE MOVE

ON SALE ALL OVER THE WORLD
 DOWNLOAD IT NOW FROM AUTOSPORT.COM



ONLINE

Top stories on AUTOSPORT.com in the past week

BUTTON WARNS VERSTAPPEN OVER REMARKS

Jenson Button was one of several drivers to give Max Verstappen a warning about his conduct last week, following the teenager's comments after his Monaco crash.

ALONSO MADE TO LOOK 'AMATEUR'

Following his radio outburst during the Canadian GP, Fernando Alonso tried to play down those comments, while explaining what he meant by his 'amateur' comment.

RICCIARDO SAYS RED BULL IS LOST

One year on from his maiden F1 victory, Daniel Ricciardo could not hide his despair as Red Bull spent the entire Canadian GP weekend off the pace.

ECCESTONE: STRATEGY GROUP MUST GO

Bernie Ecclestone tells AUTOSPORT that F1 should "stop mucking around" and scrap the Strategy Group when it comes to making F1's big decisions.

AUTOSPORT+

F1'S MOST IMPORTANT POWER STRUGGLE

Our technical expert analyses those struggling with underpowered engines, and the vexed topic of reversed grids.

ALONSO: DRIVERS LIKE AIRLINE PILOTS

Fernando Alonso's latest dig at the challenges of modern F1 cars had him suggesting it's all about managing systems rather than pushing to the limit.

the week



WRC ITALY

BT Sport 1 and 2
Thurs 1830-1930 (BTS1)/Fri 1500-1600 (BTS2)/Sun 1100-1200 (BTS1)
 Sebastien Ogier has taken the past two Italy victories, but his 2015 WRC winning streak has been halted in recent events.

Whoever wins in Italy will have conquered a tough route – stung by criticism of last year's itinerary, organisers have scheduled 10 stages across a 14-hour Saturday run. BT's live coverage is up to three stages, plus daily highlights. Highlights also appear on Motors TV and there's a post-event round-up on ITV4 at 8pm on Tuesday.



NASCAR EURO SERIES

Motors TV
Saturday 1925-2030
 Huge crowds flocked to Brands Hatch last weekend for a celebration of all things American, including headline act the NASCAR Whelen Euro Series.

Jeffrey Earnhardt, grandson of the late, great Dale Sr, competed in the series and in the UK for the first time but it was European racers Romain Iannetta and Ander Vilarino who were victorious. Motors TV has a highlights package from Brands that's repeated through the week and also gets a Premier Sports airing.



RENAULT SPORT TROPHY

Motors TV
Sat 1620-1750/Sun 0920-1005/2000-2050
 You can find live Formula Renault 3.5 coverage on Eurosport for this weekend's Hungaroring meeting, but it's also worth tracking down Motors TV's highlights shows from the World Series by Renault's new Renault Sport Trophy series.

The rapid and eye-catching RS01 cars will be in action for three races – the opening two-driver enduro, the Prestige class race and the Elite class headliner, which features ex-junior single-seater names such as 2012 Formula 2 champion Luciano Bacheta in what is admittedly currently a slender field.



JAPANESE GP 2005

Sky Sports F1
Saturday 2100-2245
 This year's Canadian Grand Prix didn't live up to expectations, so cheer yourself up by watching a race that massively exceeded them. The 2005 title battle had been wrapped up at Interlagos, but Suzuka proved the highlight of the year as Kimi Raikkonen charged from 17th on the grid to take a shock last-gasp win in a drama-packed event.

Also on the Sky retro menu this week are Ayrton Senna's famous home victory in 1993 and John Watson's milestone British GP win at the start of McLaren's Ron Dennis era in 1981.

HOT ON THE WEB THIS WEEK

YouTube DOCUMENTARY RAMPS UP LE MANS ANTICIPATION

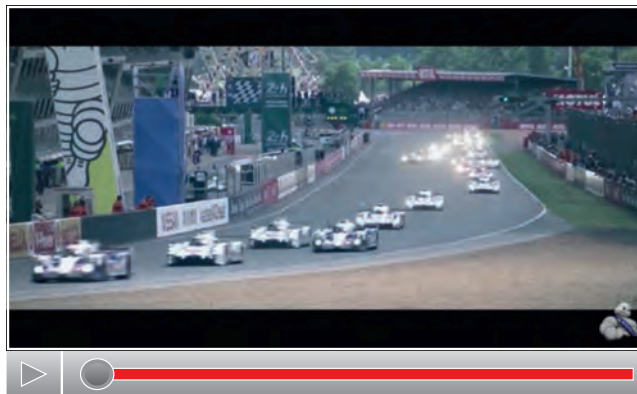

SEARCH FOR: We Are Racers: Michelin x Porsche Le Mans full documentary
 Michelin's 25-minute Le Mans appetite-whetter looks back to last year's Porsche WEC campaign, culminating in the legendary 24-hour race. Just make sure you click YouTube's subtitles button for the non-English elements of the commentary.

@AUTOSPORT TWEETERS

- | | | |
|---|---|--|
| Edd Straw
@eddstrawF1 | Matt Beer
@mattofautosport | Mark Glendenning
@m_glendenning |
| Glenn Freeman
@glenn_autosport | Stuart Codling
@CoddersF1 | Mitchell Adam
@DrMitchellAdam |
| Marcus Simmons
@MarcusSimmons54 | David Evans
@daveevansrally | Henry Hope-Frost
@henryhopefrost |
| Ian Parkes
@ianparkesf1 | Scott Mitchell
@ScottMitchell89 | Lawrence Barretto
@lawrobarretto |
| Ben Anderson
@BenAndersonAuto | Gary Watkins
@gazzasportscars | Rob Ladbrook
@LaddersMN |

INTRODUCING

Marc Miller

The US racer makes his 24-hour debut this weekend – at Le Mans of all places!



CV

Born August 24, 1975
From Michigan



2015 Continental Tire SportsCar Challenge GS class – Porsche 911; United SportsCar Championship GTD class – Dodge Viper SRT GT3-R

2014 12th CTSC ST class – Mazda MX-5
2013 7th CTSC ST class – Mazda MX-5 (2 wins)

2009 3rd SCCA Mazda MX-5 Cup (1 win, 7 podiums)

2007 3rd Thunderhill 25 Hours – Mazda MX-5

2003-06 CASCAR Super Series



Don't think you're ignorant if you've never heard of Marc Miller. The 39-year-old American isn't just making his Le Mans 24 Hours debut this weekend with the Riley Motorsports Dodge Viper squad – he's competing in his first 24-hour race full stop. In fact, he's only contested one top-tier sportscar race at home before.

Miller is better known for his exploits a rung or two down the sportscar ladder in the US. He's a former frontrunner in the Sports Car Club of America's Mazda MX-5 series and a regular in the Continental-backed series on the United SportsCar Championship undercard. He's got a pretty handy record in gearbox karting, too.

Yet that doesn't sound like the CV of a driver likely to be picked up to race at Le Mans for the first time. But it happened on this occasion because the Riley team was looking for a bronze-ranked driver to complete its line-up for an attack on the GTE Am class with one of the ex-factory Viper SRT GTS-Rs.

Miller was in the fortunate position that he had both a friend and a fan in team boss Bill Riley. They have known

each other for 15 or so years, from the days when Riley used to race gearbox karts for fun on his spare weekends. Miller had spotted for the Riley team at the Daytona 24 Hours and tested for the factory Viper squad when it was assembling its line-up for its American Le Mans Series entry in 2012.

This time around, five bronze drivers were given a try-out aboard a GT Daytona-spec Viper SRT GT3-R at Sebring for the vacant seat alongside Jeroen Bleekemolen and Ben Keating.

"Two of them weren't quick enough, and two of the other three talked their way out of it," explains Riley. "So that left us with Marc. But you know what? It feels right with him."

Miller couldn't quite believe what was happening, even though it was Riley who suggested that he might like to apply for an FIA driver ranking.

"Bill rang me and said, 'So you're bronze, right? I'm going to send you an email,'" recalls Miller. "That was the invite to Sebring. Then he asked me to test at Road Atlanta and then suggested that I might like to keep the Le Mans dates free. Then he said the PR people were going to call. I still didn't know if I'd be racing at Le Mans, or maybe I just refused to believe it."

"I was out at dinner when my phone vibrated off the table because so many people were calling and texting. That's when I knew in my mind it was really happening."

That was followed by an outing in one of the GTD Vipers at the Laguna Seca USC round in May. Riley wanted to give Miller some experience of "being around prototypes" ahead of Le Mans.

Miller is a jobbing racing driver, who combines competing with coaching duties in a range of machinery. "That's the same with any of the drivers at my level," he says. But he's refusing to look beyond his dream opportunity this weekend.

"Whenever I talk about this I have to whoa the horse," says Miller. "I don't want to take anything away from the experience by looking past it." ❧

Gary Watkins



NEXT WEEK

Le Mans 24 Hours report
Plus: Indy 2005 – the story of F1's biggest farce

Entries Now Open for the Fourth Henry Surtees Foundation Brooklands Team Karting Challenge



John Surtees cordially invites you to enter the fourth annual Henry Surtees Foundation Brooklands Team Karting Challenge taking place on Tuesday 30 June 2015. The event organised by John Surtees OBE, will be staged once again at the iconic Mercedes-Benz World, Surrey. Racing starts with practice and qualifying. Teams will then compete in a challenging 2 hour endurance race, where they battle it out in Daytona High-Performance two-stroke DMAX Birel Karts in the hope of securing the coveted 'H' trophy.

John Surtees OBE said "Each year the HSF Team Karting Challenge receives tremendous support from a host of star names from the world of motorsport, business and the entertainment industry and 2015 will be no exception. Why not put a team of four together and come and join us at the original home of motorsport at Brooklands where you will be

able to enjoy the superb facilities of Mercedes-Benz World in the company of the Henry Surtees Foundation and star guests".

The interval features a spectacular display of Surtees built Formula cars and Brooklands Museum exhibits plus 'special' vehicle demonstrations.

The day culminates in a prize giving Champagne reception courtesy of G H Mumm in the impressive state-of-the-art Mercedes-Benz World venue where the prestigious 'H' trophy is awarded to the 2015 karting champion. The Champagne and canapé reception will be hosted by Steve Rider and feature interviews with racers and celebrity guest participants, plus an incredible fundraising auction hosted by Malcolm Barber of Bonhams featuring exclusive artwork, memorabilia and experiences.



Team entry for the Brooklands Team Karting Challenge £1200 per team of 4 competitors and includes 4 x tickets to the champagne and canapé reception

Champagne & Canapé Reception

The reception is open to all HSF supporters to attend at the cost of £65 per person, per ticket

Spectators are welcome to attend the karting event FREE

For further event details, to enter a team or book tickets to the reception, please contact:
info@henrysurtreesfoundation.com

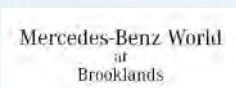



24h
LE MANS

LE MANS 24 HOURS

ROUND-THE-CLOCK **LIVE** COVERAGE



BRITISH EUROSPORT IS AVAILABLE ON
BT TV, SKY, VIRGIN MEDIA

ADDITIONAL COVERAGE
WWW.EUROSPORTPLAYER.COM